



# Cross Arm Straps, Cable Chokers, Pour-in Anchorage Connectors and Anchor Extensions

**⚠ WARNING:** Compliant fall protection equipment must only be used as it was designed and adhere to the hierarchy of controls as discussed in ANSI Z359.2. Users **MUST** read and follow all user instructions provided with the product. Before using a fall arrest system, users must be trained in the safe use of the system, as required by OSHA 29 CFR 1910.30 and 1926.503, or local safety regulations. **Misuse or failure to heed these warnings and instructions may result in injury or even death.**

WORK SAFE! WORK SMART!

## IMPORTANT

Before use, the user must read and understand these User Instructions. Keep these User Instructions for reference.

## ⚠ WARNING:

1. Failure to follow all instructions and limitations on the use of Cross Arm Straps, Cable Chokers, Pour-in Anchorage Connectors or Anchor Extensions may result in serious personal injury or death.
2. Minors, pregnant women and anyone with a history of either back or neck problems should not use this equipment.
3. Do not use Cross Arm Straps, Cable Chokers, Pour-in Anchorage Connectors and Anchor Extensions without proper training from a "competent person" as defined by OSHA 29 CFR 1910.140(b) and 1926.32(f).
4. Not all fall protection components are rated for the same user weight capacity. Only use components rated for the same weight capacity.
5. Caution must be taken when using Cross Arm Straps, Cable Chokers, Pour-in Anchorage Connectors, Anchor Extensions or other fall protection equipment near moving machinery, electrical hazards, sharp edges, or abrasive surfaces. Contact with these elements may cause equipment failure, personal injury, or death.
6. Remove any surface contamination such as concrete, stucco, roofing material, etc., that could accelerate cutting or abrasion of attached components.
7. Do not expose Cross Arm Straps, Cable Chokers, Pour-in Anchorage Connectors or Anchor Extensions to chemicals or harsh solutions which may have a harmful effect.
8. Personal fall arrest systems, including Cross Arm Straps, Cable Chokers, Pour-in Anchorage Connectors and Anchor Extensions, must be inspected prior to each use for wear, damage and other deterioration. Defective components must be immediately removed from service in accordance with the requirements of OSHA 29 CFR 1910.140 and 1926.502.
9. Striking objects horizontally due to the pendulum effect of a swing fall may cause serious injury or death.
10. Do not use if inspection reveals any defect, wear, damage, deterioration, inadequate maintenance, or unsafe condition.
11. Do not use any equipment that has been subjected to the forces of arresting a fall or if any part of the Cross Arm Straps, Cable Chokers, Pour-in Anchorage Connectors or Anchor Extensions is damaged or non-functional.
12. Only connect to the web loop end of the Pour-in Anchorage Connector using a carabiner. Do not connect a snap hook to the web loop end of the Pour-in Anchorage Connector.
13. Only Werner Co., or persons or entities authorized by Werner Co., may make repairs or alterations to the equipment.
14. Alterations or misuse may result in serious personal injury or death.

**⚠ CAUTION:** When using Cross Arm Straps, Cable Chokers, Pour-in Anchorage Connectors or Anchor Extensions, the additional length of the anchorage connector or anchor extension must be taken into consideration during the clearance calculation process.

## PURPOSE

Werner Cross Arm Straps, Cable Chokers, Pour-in Anchorage Connectors and Anchor Extensions are designed to function as an interface between the anchorage and travel restraint, work positioning, fall arrest or rescue system.

## USE INSTRUCTIONS

1. Before using a personal fall arrest system, employees must be trained in accordance with the requirements of OSHA 29 CFR 1910.30 and 1926.503 in the safe use of the system and its components.
2. The complete fall arrest system must be planned (including all components, calculating fall clearance, and swing fall) before using.
3. Users must have a rescue plan, and the means at hand to implement it, that provides for the prompt rescue of the user in the event of a fall, or assures that the user is able to rescue themselves. A fall over an edge may require special rescue measures.
4. Store Cross Arm Straps, Cable Chokers, Pour-in Anchorage Connectors and Anchor Extensions in a cool, dry, clean environment, out of direct sunlight, when not in use.
5. After a fall occurs on the system, immediately remove from service until inspected by a competent person.
6. Werner Co. will provide design information upon request.
7. Field serviceability testing is not required and is not recommended to be performed by the user.

## USE LIMITATIONS

Cross Arm Straps, Cable Chokers, Pour-in Anchorage Connectors and Anchor Extensions have been tested in compliance with the requirements of ANSI/ASSE Z359.7. Compliance and testing covers only the hardware and does not extend to the anchorage and substrate to which Cross Arm Straps, Cable Chokers, Pour-in Anchorage Connectors and Anchor Extensions are attached.

1. ANCHORAGE: Cross Arm Straps, Cable Chokers, Pour-in Anchorage Connectors and Anchor Extensions must only be used on structures capable of supporting loads applied in all directions permitted by the fall arrest system of at least: A) no less than 5,000 pounds (22.2 kN) for non-certified anchorages; or B) at least two times the maximum arresting force for certified anchorages; C) according to ANSI Z359.6, *Specifications and Design Requirements for Active Fall Protection Systems*. When more than one personal fall arrest system is attached to the anchorage, the strength in (A) or (B) must be multiplied by the number of personal fall arrest systems attached to the anchorage.
2. SUBSTRATE: Pour-in Anchorage Connectors must only be used when connected to steel rebar cast in concrete structures. The anchoring rebar must be at least 4 inches from the outside face of the poured concrete.
3. LOADING: Cross Arm Straps, Cable Chokers, Pour-in Anchorage Connectors and Anchor Extensions are permitted to be loaded in all directions.
4. CONNECTION: Only one travel restraint, work positioning, fall arrest, or rescue system may be attached to an individual connect point.
5. EXTREME TEMPERATURE: Cross Arm Straps, Cable Chokers, Pour-in Anchorage Connectors and Anchor Extensions are designed to be used in temperatures ranging from -40°F to +130°F (-40°C to +54°C). Protection should be provided when used near welding, metal cutting or similar activities. Contact Werner Co. with any questions concerning high temperature environments.



# Cross Arm Straps, Cable Chokers, Pour-in Anchorage Connectors and Anchor Extensions

- 6. **ELECTRICAL HAZARDS:** Use extreme caution when working near high voltage power lines due to the possibility of electric current flowing through Cross Arm Straps, Cable Chokers, Pour-in Anchorage Connectors, Anchor Extensions or connecting components.
- 7. **RESCUE:** In the event of a fall over the edge, special rescue measures may be required. A rescue plan must be in place.

## COMPATIBILITY LIMITATIONS

All connecting subsystems must only be coupled to compatible connectors. OSHA 29 CFR 1910.140 and 1926.502 prohibit snap hooks from being engaged to certain objects unless two requirements are met: snap hook must be a locking type and must be “designed for” making such a connection. Under OSHA “designed for” means that the manufacturer of the snap hook specifically designed the snap hook to be used to connect to the equipment in question.

The following connections must be avoided because they can result in rollout\* when a non-locking snap hook is used:

- Direct connection of a snap hook to horizontal lifeline.
- Two (or more) snap hooks connected to one D-ring.
- Two snap hooks connected to each other.
- A snap hook connected back on its integral lanyard.
- A snap hook connected to a webbing loop or webbing lanyard.
- Improper dimensions of the D-ring, rebar, or other connection point in relation to the snap hook dimensions that would allow the snap hook keeper to be depressed by a turning motion of the snap hook.

\***Rollout:** A process by which a snap hook or carabiner unintentionally disengages from another connector or object to which it is coupled.

## INSTALLATION

### CROSS ARM STRAPS

With labels on outward facing surface, pass Cross Arm Strap over structure with ends dangling on either side. Ensure abrasion pad is against the structure. Pass the small D-ring through the larger O-ring, or web loop on the other end. Pull small D-ring to tighten (cinch) on the structure. Continue to pass the extended web end around the structure until there is not enough length left to make another complete revolution.

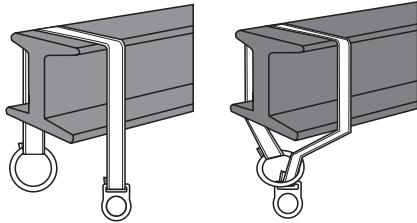

Cinch the anchor by passing the smaller D-ring through the larger O-ring or web loop. Only connect to the small D-ring of the Cross Arm Strap.

### CABLE CHOKERS

Pass cable over structure with ends dangling on either side. Pass the small O-ring on one end through the larger O-ring on the other end. Pull small O-ring to tighten (cinch) on the structure. Continue to pass the extended cable end around the structure until there is not enough length left to make another complete

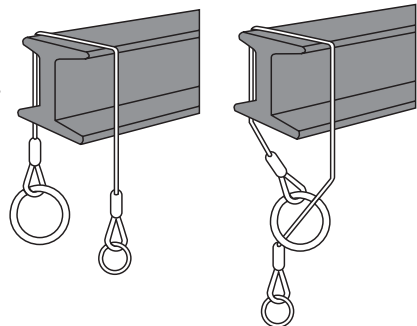

revolution. Cinch the anchor by passing the smaller O-ring through the larger O-ring. Only connect to the small O-ring of the Cable Choker.

### POUR-IN ANCHORAGE CONNECTORS

Pour-in Anchorage Connectors may be installed in walls, ceilings, or floors. The label on the Pour-in Anchorage Connector must be viewable after installation. The orientation of the anchoring rebar may be vertical or horizontal. Cinch the Pour-in Anchorage Connector to the rebar by passing the small D-ring or web loop through the opposite end web loop around the rebar and pulling tight. The Pour-in Anchorage Connector may also attach to the rebar by sliding the web loop over the rebar. Orientation of the web exiting the poured concrete must be such that the web does not fold over. It must lay flat. The anchoring rebar must be at least 4 inches (10 cm) from the outside face of the poured concrete. The abrasion pad of the Pour-in Anchorage Connector must be installed so that the abrasion pad exits the concrete. Only connect to the web loop end of the Pour-in Anchorage Connector using a carabiner. Do not connect a snap hook to the web loop end of the Pour-in Anchorage Connector.

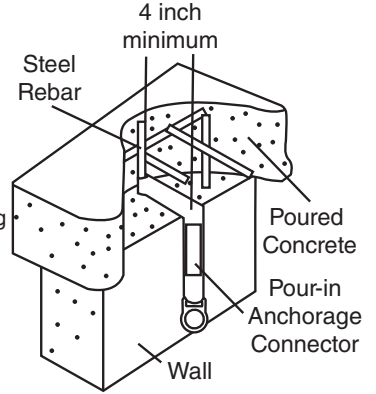

To remove, cut off the Pour-in Anchorage Connector exiting the poured concrete and discard.

**WARNING:** Only connect to the web loop end of the Pour-in Anchorage Connector using a carabiner. Do not connect a snap hook to the web loop end of the Pour-in Anchorage Connector.

### ANCHOR EXTENSIONS

The additional length of the anchor extension must be taken into consideration during the clearance calculation process. Connect the snap hook of the Anchor Extension to the existing anchorage connector.

Do not use the Anchor Extension as a Cable Choker. Only connect to the O-ring of the Anchor Extension.

### INSPECTION

All components of Cross Arm Straps, Cable Chokers, Pour-in Anchorage Connectors and Anchor Extensions must be inspected prior to each use and annually by an OSHA defined competent person other than the user. Local, state, governmental and jurisdictional agencies governing occupational safety may require the user to conduct more frequent or mandatory inspections.

**WARNING:** If inspection reveals any defect, inadequate maintenance, or unsafe condition, remove from service until a competent person, as defined by OSHA 29 CFR 1910.140(b) and 1926.32(f), can determine the need for authorized repair or disposal.

**WARNING:** Any equipment that has been subjected to the forces of arresting a fall, or that has a deployed load indicator, must be removed from service until a competent person can determine the need for authorized repair or disposal.



# Cross Arm Straps, Cable Chokers, Pour-in Anchorage Connectors and Anchor Extensions

To inspect webbing, bend a 6 - 8 inch portion of the webbing into an upside down 'U' shape. Continue along all webbing and rope inspecting for tears, cuts, fraying, abrasion, discoloration, burns, holes, mold, pulled or broken stitches, or other signs of wear and damage.

Sewn terminations should be secure, complete, and not visibly damaged.

Cable must be inspected for kinks, broken strands, corrosion, abrasion, or other signs of wear and/or damage. Swaged terminations must be secure with the thimble tight and no visible damage.

All snap hooks on product must be able to close and lock automatically. All hardware must be free of cracks, sharp edges, deformation, corrosion, or any evidence of defect.

All Cross Arm Straps, Cable Chokers, Pour-in Anchorage Connectors and Anchor Extensions must be free of corrosion, chemical attack, alteration, excessive heating or wear.

All markings must be legible and attached to the product.

All components of the fall arrest system must be inspected. See User Instructions supplied with each product.

**⚠ WARNING: Only Werner Co., or persons or entities authorized in writing by Werner Co., may make repairs or alterations to the equipment.**

## CLEANING AND MAINTENANCE

Cross Arm Straps, Cable Chokers, Pour-in Anchorage Connectors and Anchor Extensions may be wiped down with a mild detergent and clean water solution, and rinsed with a dampened clean cloth to remove detergent. The hardware can also be wiped down to remove grease or dirt with a clean dry cloth.

Model/Modelo:  
Mark Number/  
Número de Mark de: **2**  
Material/  
Materiales:  
Length/  
Longitud:  
Date of Manufacture/  
Fecha de la fabricación:  
Serial Number/  
Número de serie:

Minimum Breaking Strength (MBS)/ Resistencia Mínima a la rotura: 5,000 lbs (22.2kN)

Assembled in/  
Ensamblado en:

**WERNER**

Inspection Log/Registro de Inspección

Year / Año	Year 2 / Año 2	Year 3 / Año 3	Year 4 / Año 4	Year 5 / Año 5	Year 6 / Año 6

Standards/Estándares  
ANSI Z359.18-2017; OSHA 1910-1926  
555 Pierre Rd., Ste 300, Itasca, IL 60143  
1-888-923-3370  
© 2021 Werner Co., P/N 194279-03 Rev E 5/21

**WARNING**

Read User Manual and understand all instructions and warnings. Refer to the instruction manual for stability and compatibility limitations. If user manual is missing contact Werner Co. for a replacement copy. Product must be inspected prior to each use according to instructions in manual, then periodically by a competent person who is not the user. User repairs or alterations are **NOT** permitted. Avoid exposure to sharp edges, chemicals, machinery and environmental hazards that could weaken the materials. Verify that connectors are compatible (see instruction manual). OSHA, CSA and local regulations require that workers receive training in the proper use and limitations of fall restraint equipment.

FAILURE TO READ AND HEED ALL WARNINGS COULD RESULT IN INJURY OR DEATH!

© 2011 Werner Co., P/N 104277-01

**ADVERTENCIA**

Debe leer el manual del usuario y entender todas las instrucciones y advertencias. Refera al manual de la instrucción para las limitaciones de la estabilidad y de la compatibilidad. Si el manual del usuario está faltando, comuníquese con Werner Co. para obtener una copia de reemplazo. Antes de cada uso, el producto debe ser inspeccionado periódicamente por una persona capacitada que no sea el usuario. **NO** se permiten reparaciones o alteraciones por parte del usuario. Verifique que los conectores sean compatibles (véase el manual de la instrucción). El OSHA, CSA y las regulaciones locales requieren que los trabajadores reciban el entrenamiento en el uso y las limitaciones apropiadas del equipo del alojamiento de la caída.

NO LEER Y NO TENER EN CUENTA TODAS LAS ADVERTENCIAS PODRÁ RESULTAR EN LESIONES O LA MUERTE!

© 2011 Werner Co., P/N 104277-01

Model No.	Material	Connection End Size	Product Length	Webbing Width	Pass Thru End	Minimum Breaking Strength (MBS)	Approx. Weight	Compliance Standards
A110112	Polyester Webbing	2 1/8 in (54 mm)	12 ft (3.66 m)	1.75 in (44.5 mm)	O-Ring	5,000 lbs (22.2 kN)	1.7 lbs (0.77 kg)	ANSI Z359.18-2017 Type A OSHA 1910 & 1926
A111002	Polyester/Nylon	2 1/8 in (54 mm)	2 ft (0.61 m)	3 in (76.2 mm)	O-Ring	5,000 lbs (22.2 kN)	1 lb (0.45 kg)	ANSI Z359.18-2017 Type A OSHA 1910 & 1926
A111003	Polyester/Nylon	2 1/8 in (54 mm)	3 ft (0.91 m)	3 in (76.2 mm)	O-Ring	5,000 lbs (22.2 kN)	1.2 lb (0.54 kg)	ANSI Z359.18-2017 Type A OSHA 1910 & 1926
A111004	Polyester/Nylon	2 1/8 in (54 mm)	4 ft (1.22 m)	3 in (76.2 mm)	O-Ring	5,000 lbs (22.2 kN)	1.3 lb (0.59 kg)	ANSI Z359.18-2017 Type A OSHA 1910 & 1926
A111006	Polyester/Nylon	2 1/8 in (54 mm)	6 ft (1.83 m)	3 in (76.2 mm)	O-Ring	5,000 lbs (22.2 kN)	1.5 lb (0.68 kg)	ANSI Z359.18-2017 Type A OSHA 1910 & 1926
A111008	Polyester/Nylon	2 1/8 in (54 mm)	8 ft (2.44 m)	3 in (76.2 mm)	O-Ring	5,000 lbs (22.2 kN)	1.7 lb (0.77 kg)	ANSI Z359.18-2017 Type A OSHA 1910 & 1926
A111010	Polyester/Nylon	2 1/8 in (54 mm)	10 ft (3.05 m)	3 in (76.2 mm)	O-Ring	5,000 lbs (22.2 kN)	2.0 lbs (0.91 kg)	ANSI Z359.18-2017 Type A OSHA 1910 & 1926
A111012	Polyester/Nylon	2 1/8 in (54 mm)	12 ft (3.66 m)	3 in (76.2 mm)	O-Ring	5,000 lbs (22.2 kN)	2.3 lbs (1.04 kg)	ANSI Z359.18-2017 Type A OSHA 1910 & 1926
A111015	Polyester	2 1/8 in (54 mm)	15 ft (4.6 m)	2 in (50.8 mm)	O-Ring	5,000 lbs (22.2 kN)	2.4 lbs (1.09 kg)	ANSI Z359.18-2017 Type A OSHA 1910 & 1926
A111020	Polyester	2 1/8 in (54 mm)	20 ft (6.1 m)	2 in (50.8 mm)	O-Ring	5,000 lbs (22.2 kN)	2.9 lbs (1.32 kg)	ANSI Z359.18-2017 Type A OSHA 1910 & 1926
A111025	Polyester	2 1/8 in (54 mm)	25 ft (7.6 m)	2 in (50.8 mm)	O-Ring	5,000 lbs (22.2 kN)	3.5 lbs (1.59 kg)	ANSI Z359.18-2017 Type A OSHA 1910 & 1926
A111030	Polyester	2 1/8 in (54 mm)	30 ft (9.1 m)	2 in (50.8 mm)	O-Ring	5,000 lbs (22.2 kN)	4.0 lbs (1.81 kg)	ANSI Z359.18-2017 Type A OSHA 1910 & 1926

# User Instruction Manual





# Cross Arm Straps, Cable Chokers, Pour-in Anchorage Connectors and Anchor Extensions

Model No.	Material	Connection End Size	Product Length	Webbing Width	Pass Thru End	Minimum Breaking Strength (MBS)	Approx. Weight	Compliance Standards
A111102	Polyester/Nylon	2 1/8 in (54 mm)	2 ft (0.61 m)	3 in (76.2 mm)	Web Loop	5,000 lbs (22.2 kN)	0.75 lbs (0.34 kg)	ANSI Z359.18-2017 Type A OSHA 1910 & 1926
A111103	Polyester/Nylon	2 1/8 in (54 mm)	3 ft (0.91 m)	3 in (76.2 mm)	Web Loop	5,000 lbs (22.2 kN)	0.80 lbs (0.36 kg)	ANSI Z359.18-2017 Type A OSHA 1910 & 1926
A111104	Polyester/Nylon	2 1/8 in (54 mm)	4 ft (1.22 m)	3 in (76.2 mm)	Web Loop	5,000 lbs (22.2 kN)	0.90 lbs (0.41 kg)	ANSI Z359.18-2017 Type A OSHA 1910 & 1926
A111106	Polyester/Nylon	2 1/8 in (54 mm)	6 ft (1.83 m)	3 in (76.2 mm)	Web Loop	5,000 lbs (22.2 kN)	1.13 lbs (0.51 kg)	ANSI Z359.18-2017 Type A OSHA 1910 & 1926
A111108	Polyester/Nylon	2 1/8 in (54 mm)	8 ft (2.44 m)	3 in (76.2 mm)	Web Loop	5,000 lbs (22.2 kN)	1.39 lbs (0.63 kg)	ANSI Z359.18-2017 Type A OSHA 1910 & 1926
A112002	5/16 in (8 mm) wire rope with 1/16 (1.5 mm) vinyl coating	2 5/16 in (58.7 mm)	2 ft (0.61 m)	N/A	O-Ring	5,000 lbs (22.2 kN)	1.80 lbs (0.82 kg)	ANSI Z359.18-2017 Type A OSHA 1910 & 1926
A112003	5/16 in (8 mm) wire rope with 1/16 (1.5 mm) vinyl coating	2 5/16 in (58.7 mm)	3 ft (0.91 m)	N/A	O-Ring	5,000 lbs (22.2 kN)	2.00 lbs (0.91 kg)	ANSI Z359.18-2017 Type A OSHA 1910 & 1926
A112004	5/16 in (8 mm) wire rope with 1/16 (1.5 mm) vinyl coating	2 5/16 in (58.7 mm)	4 ft (1.22 m)	N/A	O-Ring	5,000 lbs (22.2 kN)	2.18 lbs (0.99 kg)	ANSI Z359.18-2017 Type A OSHA 1910 & 1926
A112004NR	5/16 in (8 mm) wire rope with 1/16 (1.5 mm) vinyl coating	2 5/16 in (58.7 mm)	4 ft (1.22 m)	N/A	N/A	5,000 lbs (22.2 kN)	0.94 lbs (0.43 kg)	ANSI Z359.18-2017 Type A OSHA 1910 & 1926
A112006	5/16 in (8 mm) wire rope with 1/16 (1.5 mm) vinyl coating	2 5/16 in (58.7 mm)	6 ft (1.83 m)	N/A	O-Ring	5,000 lbs (22.2 kN)	2.57 lbs (1.17 kg)	ANSI Z359.18-2017 Type A OSHA 1910 & 1926
A112008	5/16 in (8 mm) wire rope with 1/16 (1.5 mm) vinyl coating	2 5/16 in (58.7 mm)	8 ft (2.44 m)	N/A	O-Ring	5,000 lbs (22.2 kN)	3.00 lbs (1.36 kg)	ANSI Z359.18-2017 Type A OSHA 1910 & 1926
A113002	1/4 in (6 mm) wire rope with 1/16 (1.5 mm) vinyl coating	2 5/16 in (58.7 mm)	2 ft (0.61 m)	N/A	Snap Hook	5,000 lbs (22.2 kN)	1.9 lbs (0.86 kg)	ANSI Z359.18-2017 Type A OSHA 1910 & 1926
A113003	1/4 in (6 mm) wire rope with 1/16 (1.5 mm) vinyl coating	2 5/16 in (58.7 mm)	3 ft (0.91 m)	N/A	Snap Hook	5,000 lbs (22.2 kN)	2.0 lbs (0.91 kg)	ANSI Z359.18-2017 Type A OSHA 1910 & 1926
A113004	1/4 in (6 mm) wire rope with 1/16 (1.5 mm) vinyl coating	2 5/16 in (58.7 mm)	4 ft (1.22 m)	N/A	Snap Hook	5,000 lbs (22.2 kN)	2.1 lbs (0.95 kg)	ANSI Z359.18-2017 Type A OSHA 1910 & 1926
A113006	1/4 in (6 mm) wire rope with 1/16 (1.5 mm) vinyl coating	2 5/16 in (58.7 mm)	6 ft (1.83 m)	N/A	Snap Hook	5,000 lbs (22.2 kN)	2.3 lbs (1.04 kg)	ANSI Z359.18-2017 Type A OSHA 1910 & 1926
A113008	1/4 in (6 mm) wire rope with 1/16 (1.5 mm) vinyl coating	2 5/16 in (58.7 mm)	8 ft (2.44 m)	N/A	Snap Hook	5,000 lbs (22.2 kN)	2.6 lbs (1.18 kg)	ANSI Z359.18-2017 Type A OSHA 1910 & 1926
A211002	Polyester Webbing	2 1/8 in (54 mm)	2 ft (0.61 m)	2 in (50.8 mm)	Web Loop	5,000 lbs (22.2 kN)	0.52 lbs (0.24 kg)	ANSI Z359.18-2017 Type A OSHA 1910 & 1926
A211003	Polyester Webbing	2 1/8 in (54 mm)	3 ft (0.91 m)	2 in (50.8 mm)	Web Loop	5,000 lbs (22.2 kN)	0.61 lbs (0.28 kg)	ANSI Z359.18-2017 Type A OSHA 1910 & 1926
A211004	Polyester Webbing	2 1/8 in (54 mm)	4 ft (1.22 m)	2 in (50.8 mm)	Web Loop	5,000 lbs (22.2 kN)	0.65 lbs (0.30 kg)	ANSI Z359.18-2017 Type A OSHA 1910 & 1926
A211006	Polyester Webbing	2 1/8 in (54 mm)	6 ft (1.83 m)	2 in (50.8 mm)	Web Loop	5,000 lbs (22.2 kN)	0.76 lbs (0.34 kg)	ANSI Z359.18-2017 Type A OSHA 1910 & 1926
A211010	Polyester Webbing	2 1/8 in (54 mm)	10 ft (3.05 m)	2 in (50.8 mm)	Web Loop	5,000 lbs (22.2 kN)	0.84 lbs (0.38 kg)	ANSI Z359.18-2017 Type A OSHA 1910 & 1926
A211103	Polyester Webbing	Web Loop	3 ft (0.91 m)	2 in (50.8 mm)	Web Loop	5,000 lbs (22.2 kN)	0.33 lbs (0.15 kg)	ANSI Z359.18-2017 Type A OSHA 1910 & 1926
A211104	Polyester Webbing	Web Loop	4 ft (1.22 m)	2 in (50.8 mm)	Web Loop	5,000 lbs (22.2 kN)	0.37 lbs (0.18 kg)	ANSI Z359.18-2017 Type A OSHA 1910 & 1926
A211106	Polyester Webbing	Web Loop	6 ft (1.83 m)	2 in (50.8 mm)	Web Loop	5,000 lbs (22.2 kN)	0.46 lbs (0.21 kg)	ANSI Z359.18-2017 Type A OSHA 1910 & 1926

## User Instruction Manual

Werner Co. Corporate Headquarters: 555 Pierce Road, Suite 300, Itasca, IL 60143

103774-03 ©2021 Werner Co. Rev G 05/21

TEL: 888-523-3370 FAX: (724) 588-0315 www.WernerCo.com