

Installation Instructions

Read these instructions completely before attempting to install the Vertical EconoMi\$er X Accessory.

CONTENTS

SAFETY CONSIDERATIONS1
GENERAL1
EconoMi\$er X Sensor Usage2
ACCESSORIES LIST2
WIRING DIAGRAMS5-7
INSTALLATION2-8
EconoMi\$er X Standard Sensors8
EconoMi\$er X Control Modes8-14
OPERATION16
TROUBLESHOOTING17

SAFETY CONSIDERATIONS

Improper installation, adjustment, alteration, service, maintenance, or use can cause explosion, fire, electrical shock or other conditions which may cause personal injury or property damage. Consult a qualified installer, service agency, or your distributor or branch for information or assistance. The qualified installer or agency must use factory-authorized kits or accessories when modifying this product. Refer to the individual instructions packaged with the kits or accessories when installing.

Follow all safety codes. Wear safety glasses and work gloves. Use quenching cloths for brazing operations and have a fire extinguisher available. Read these instructions thoroughly and follow all warnings or cautions attached to the unit. Consult local building codes and appropriate national electrical codes (in USE, ANSI/NFPA70, National Electrical Code (NEC); in Canada, CSA C22.1) for special requirements.

It is important to recognize safety information. This is the safety-alert symbol . When you see this symbol on the unit and in instructions or manuals, be alert to the potential for personal injury.

Understand the signal words DANGER, WARNING, CAUTION, and NOTE. These words are used with the safety-alert symbol.

DANGER identifies the most serious hazards which **will** result in severe personal injury or death. WARNING signifies hazards which **could** result in personal injury or death. CAUTION is used to identify unsafe practices, which **may** result in minor personal injury or product and property damage.

NOTE is used to highlight suggestions which **will** result in enhanced installation, reliability, or operation.

WARNING

ELECTRICAL SHOCK HAZARD

Failure to follow this warning could cause personal injury or death. Before performing service or maintenance operations on the unit, always turn off main power switch to unit and install lock(s) and lockout tag(s). Unit may have more than one power switch. Ensure electrical service to rooftop unit agrees with voltage and amperage listed on the unit rating plate.

CAUTION

CUT HAZARD

Failure to follow this caution may result in personal injury. Sheet metal parts may have sharp edges or burrs. Use care and wear appropriate protective clothing, safety glasses and gloves when handling parts and servicing roof top units.

GENERAL

IMPORTANT: These economizers meet the economizer requirements as laid out in California’s Title 24 mandatory section 120.2 (fault detection and diagnostics).

The EconoMi\$er X system utilizes the latest technology available for integrating the use of free cooling with mechanical cooling for packaged rooftop units. The solid-state control system optimizes energy consumption, zone comfort, and equipment cycling by operating the compressors when the outdoor-air temperature is too warm, integrating the compressor with outdoor air when free cooling is available, and locking out the compressor when outdoor-air temperature is too cold. Demand control ventilation is supported.

This EconoMi\$er X can be used with 1, 2, or 3 speed (48/50LC 07-12) units.

The EconoMi\$er X system utilizes gear-drive technology with a direct-mount spring return actuator that will close upon loss of power. The EconoMi\$er X system comes standard with an outdoor air temperature sensor, mixed air temperature sensor. Outdoor enthalpy, indoor enthalpy, indoor temperature, and CO2 sensors are available for field installation. See Table 3 for sensor usage.

Standard barometric relief dampers provide natural building pressurization control. An optional power exhaust system is available for applications requiring even greater exhaust capabilities. The power exhaust set point is adjustable at the EconoMi\$er X controller.

See Table 1 for package usage. See Table 2 for package contents. See Table 3 for sensor usage.

Table 1 - Package Usage

UNIT SIZE	PART NUMBER
Small Cabinet, Footprint size: 46 3/4" x 74 3/8"	CRECOMZR076A00
Large Cabinet, Footprint size: 58 1/2" x 88 1/8"	CRECOMZR078A00
Extra-Large Cabinet, Footprint size: 63 3/8" x 115 7/8"	CRECOMZR080A00

Table 2 - Package Contents

PACKAGE NO.	QTY	CONTENTS	
CRECOMZR076A00, CRECOMZR078A00	1	Hood Top and Sides	
	1	Hood Divider	
	1	Aluminum Filter	
	18	Screws	
	1	EconoMi\$er X Assembly	
	1	HH79ZZ007 Mixed (supply) Temperature Sensor	
	1	48TMHSRSE--A20 Harness	
CRECOMZR080A00	1	Hood Top and Sides	
	1	Hood Divider	
	1	Hood Filter Divider	
	2	Aluminum Filters	
	1	Hardware Bag	
	1	EconoMi\$er X Assembly	
	1	HH79ZZ007 Mixed (supply) Temperature Sensor	
		1	48TMHSRSE--A20 Harness

Table 3 - EconoMi\$er X Sensor Usage

APPLICATION	ECONOMISER X WITH OUTDOOR AIR DRY BULB SENSOR		
	Accessories Required		
Outdoor Air Dry Bulb	HH79ZZ007 is factory installed on economizer		
Mixed Air Sensor	HH79ZZ007 provided with economizer and field installed in blower compartment		
Single Enthalpy	HH57AC081		
Differential Enthalpy	HH57AC081		
CO ₂ for DCV Control Using a Wall-Mounted CO ₂ Sensor	33ZCSENCO2 or CGCDXSEN004A00		
CO ₂ for DCV Control Using a Duct-Mounted CO ₂ Sensor	33ZCSENCO2 or CGCDXSEN004A00† and 33ZCASP02 or CGCDXASP00100**	OR	CRCBDIOX005A00††

†33ZCSENCO2 and CGCDXSEN004A00 are accessory CO2 sensors.
 **33ZCASP02 and CGCDXASP00100 are accessory aspirator boxes required for duct-mounted applications.
 ††CRCBDIOX005A00 is an accessory that contains both 33ZCSENCO2 and 33ZCASP02 accessories.

ACCESSORIES LIST

The EconoMi\$er X has several field-installed accessories available to optimize performance. Refer to Table 4 for authorized parts and power exhaust descriptions

Table 4 - EconoMi\$er X Field-Installed Accessories

DESCRIPTION	PART NUMBER
Small Cabinet Power Exhaust 208-230 v 1 Ph	CRPWREXH030A01
Small Cabinet Power Exhaust 460 v 3Ph	CRPWREXH021A01
Large Cabinet Power Exhaust 208-230 v 1 Ph	CRPWREXH022A01
Large Cabinet Power Exhaust 460 v 3 Ph	CRPWREXH023A01
Extra Large Cabinet Power Exhaust 208-230 v 1 Ph	CRPWREXH080A00
Extra Large Cabinet Power Exhaust 460 v 3 Ph	CRPWREXH081A00
Outdoor Air Enthalpy Sensor	HH57AC081
Indoor Air Enthalpy Sensor	HH57AC081
Return Air CO ₂ Sensor (4 to 20 mA)	CRCBDIOX005A00
CO ₂ Room Sensor (4 to 20 mA)	33ZCSENCO2 or CGCDXSEN004A00
Aspirator Box for Duct Mount CO ₂ Sensor (4 to 20 mA)	33ZCASP02 or CGCDXASP001A00
Space Temperature and CO ₂ Room Sensor with Override (4 to 20 mA)	33ZCT55CO2
Space Temperature and CO ₂ Room Sensor with Override and Set Point (4 to 20 mA)	33ZCT56CO2

INSTALLATION

1. Turn off unit power supply(s) and install lockout tag.

⚠ WARNING

ELECTRICAL SHOCK HAZARD
 Failure to follow this warning could result in personal injury and/or death.
 Disconnect power supply and install lockout tag before attempting to install accessory.

2. Remove the existing unit filter access panel. Raise the panel and swing the bottom outward. The panel is now disengaged from the track and can be removed. (See Fig. 2.)
3. Remove the indoor coil access panel and discard. (See Fig. 2.)
4. The EconoMi\$er X hood components are shipped with the EconoMi\$er X. Remove hood from packaging. The hood top and sides are shipped factory assembled.

NOTE: If the power exhaust accessory is to be installed on the unit, the hood shipped with the EconoMi\$er X will not be used and may be discarded. Save the aluminum filter for use in the power exhaust hood assembly.

5. Insert the hood divider between the hood sides. (See Fig. 3) Secure hood divider with 2 screws (provided) on each hood side. Screws should go through the hood sides into the divider. The hood divider is also used as the bottom filter rack for the aluminum filter. On hood for extra large cabinet install filter divider. (See Fig. 4A.)
6. Set the EconoMi\$er X upright. (See Fig. 5.)
7. Slide the EconoMi\$er X assembly into the rooftop unit. (See Fig. 5). On small and large cabinets be sure to engage the rear EconoMi\$er X flange under the tabs in the return-air opening of the unit base. (See Fig. 6)
8. Secure the EconoMi\$er X to unit along side and bottom flanges using the screws provided.
9. Remove the tape securing the relief dampers in place.
10. Remove and save the 12-pin jumper plug from the unit wiring harness (located in the upper left corner of the unit). Insert the EconoMi\$er X plug into the unit wiring harness. Refer to Fig. 7 and 8 for wiring details.

NOTE: The 12-pin jumper plug should be saved for future use, in the event that the EconoMi\$er X is removed from the unit. The jumper plug is not needed as long as the EconoMi\$er X is installed.

11. If EconoMi\$er X will be operating under enthalpy control, replace the factory installed HH79ZZ007 outdoor dry bulb temperature sensor with accessory enthalpy sensor HH57AC081. (See Fig. 1.)
12. Remove the indoor fan motor access panel. (See Fig. 9.)
13. The mixed (or supply) air temperature sensor looks like an eyelet terminal with wires running to it. The sensor is located on the “crimp end” and is sealed from moisture. Locate the sensor in the economizer hardware bag. Mount the supply air temperature sensor (provided) to the lower left section of the indoor fan blower housing. (See Fig. 10.) Use the screw provided and use existing hole. Locate the orange and brown wires in wire bundle in the indoor fan section. Connect the orange and brown wires to the corresponding connections on the supply air temperature sensor. (See Fig. 8.)

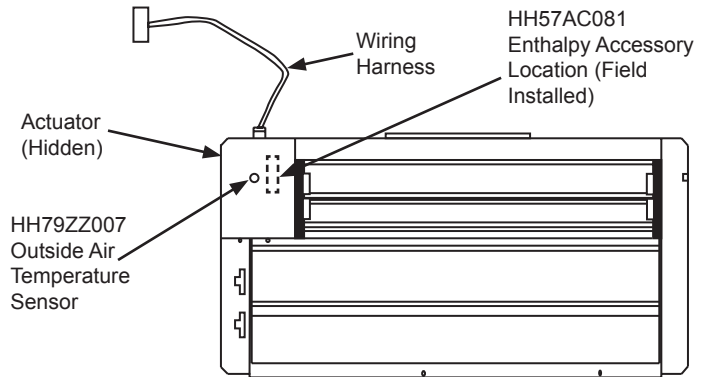

Fig. 1 - EconoMi\$er X Component Locations — (Small Cabinet Economizer Shown)

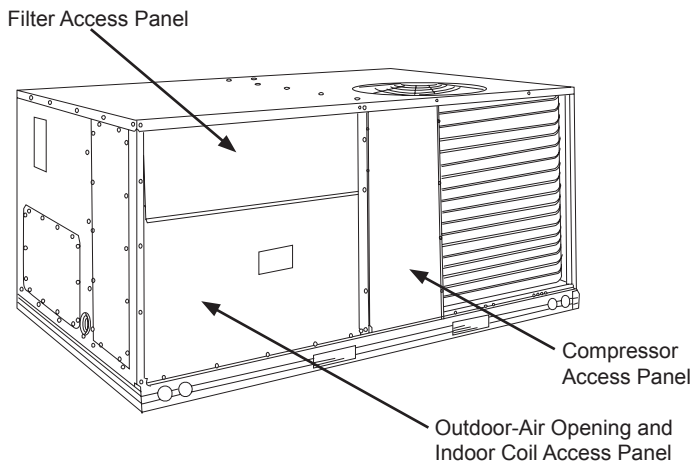

Fig. 2 - Typical Outdoor-Air Section Access Panel Locations

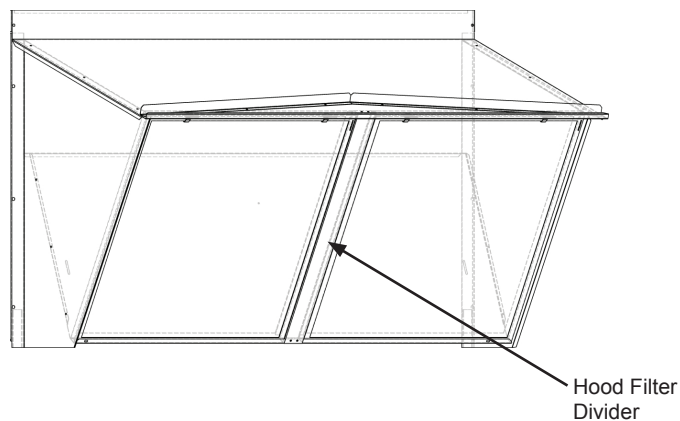

Fig. 4A - Hood for Extra Large Cabinet

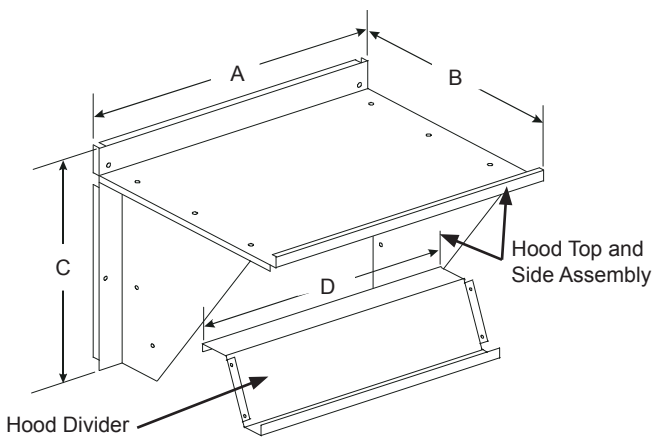

Fig. 3 - Hood Assembly

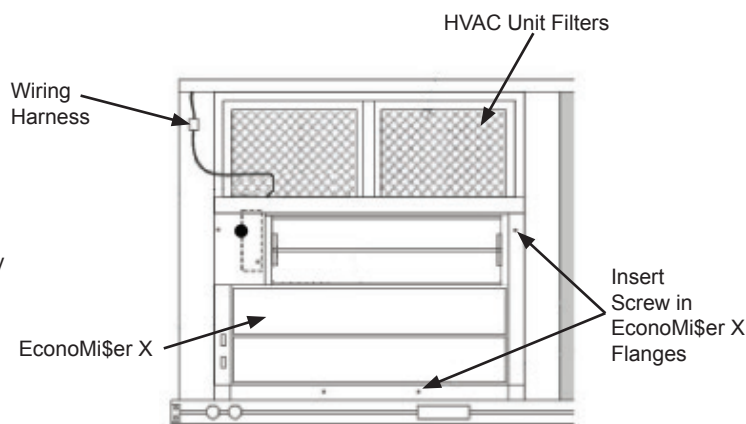

Fig. 5 - EconoMi\$er X Installed in HVAC Unit (Small Cabinet Economizer Shown)

ECONOMIZER P/N	A	B	C	D	SHIP WT.
CRECOMZR076A00	33.37"	17.43"	19.05"	29.5"	55 lb
CRECOMZR078A00	40.37"	22.28"	24.48"	36.27"	80lb
CRECOMZR080A00	52.92"	27.03"	33.41"	49.92"	98lb

NOTE: The CRECOMZR080A00 hood has 2 aluminum filters and a hood filter divider that installs between the filters. (See Fig. 5A.)

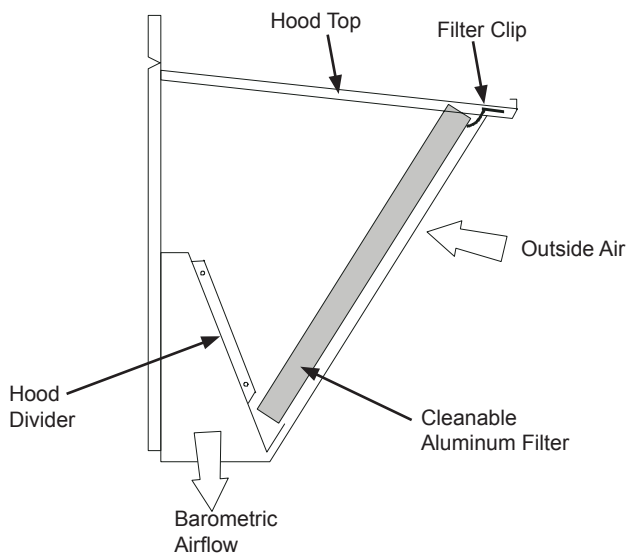

Fig. 4 - Filter Installation

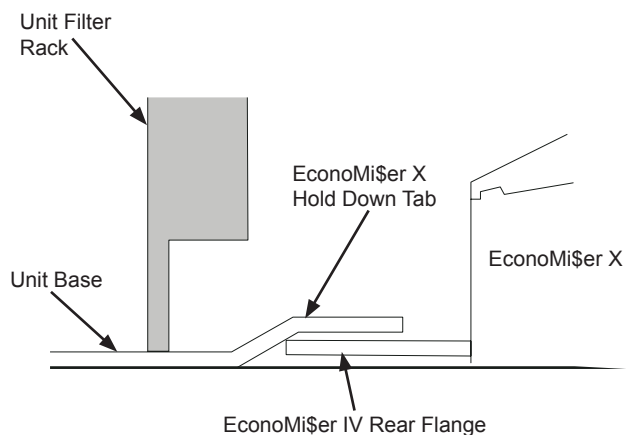

Fig. 6 - Rear EconoMi\$er X Flange Installation (Small and Large Cabinet)

- While everything is open install and wire any other accessories and/or sensors as applicable and convenient, per their installation instructions and/or the Configuration section of this instruction. Some accessories require that unit ducting already be installed.

NOTE: If also installing a power exhaust accessory, skip step 16 and follow the power exhaust instructions instead.

- Install the EconoMi\$er X hood over the EconoMi\$er X. Use screws provided.
- The W7220 EconoMi\$er X controller is shipped mounted to a bracket. Install the controller / bracket in the top left corner of the unit control box as shown in wiring diagram, Fig. 8. Screw in place through pre-punched holes.
- For 1 and 2 speed units connect the plugs coming from the

controller as shown in wiring diagram, Fig. 7 and 8A.

NOTE: Provided 48TMHSRSE--A20 harness will be connected as shown below.

- For 3 speed (48/50LC 07-12) units, the harness attached to the W7220 econoMi\$er X controller must be removed, and can be discarded. Locate harness 48LCHSRADH--A00 shipped in plastic bag in the control box of unit. Attach this harness to the W7220 controller as shown in Fig 8B and 8C.

NOTE: Harness 48TMHSRSE--A20 provided with economizer is not used with 3 speed (48/50LC 07-12) units.

- Adjust controller settings (minimum position, outside air, etc.) per instructions detailed later in this instruction.
- Follow all local and other applicable codes.

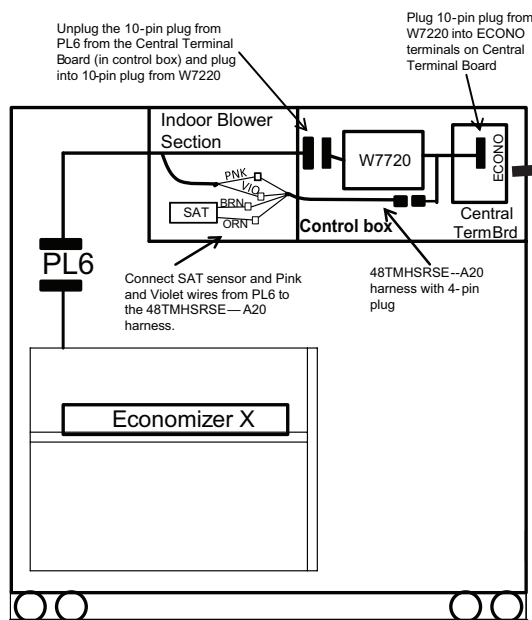
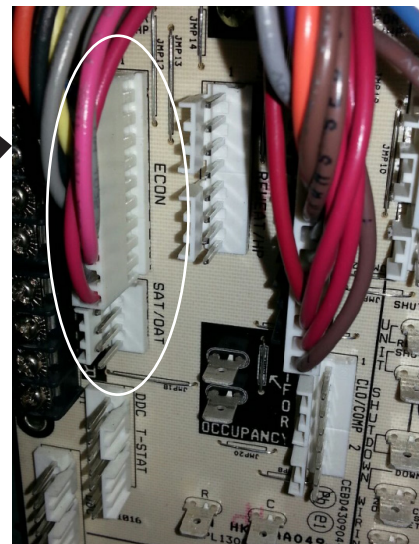

Fig. 7 - Harness Detail



- Connect other 10-pin plug from W7220 controller into ECONO terminals on CTB. See picture above.
- Connect 4-pin plug from the W7220 controller to the 4-pin 48TMHSRSE—A20 harness provided with economizer accessory.
- Route 48TMHSRSE—A20 harness back to the indoor blower section of the unit.
- Mount Supply (or Mixed) Air Temperature sensor, and connect Brown and Orange wires from harness to the SAT.
- Connect Pink and Violet wires from 48TMHSRSE—A20 harness to the Pink and Violet wires from PL6 economizer harness

WIRING INSTRUCTIONS FOR 1 AND 2 SPEED UNITS:

- Install W7220 (with harnesses attached) in unit control box. See wiring diagram in instructions.
- Unplug econo harness from PL6 with 10-pin plug shown above in picture, from Central Terminal Board (CTB).
- Attach 10-pin plug disconnected from (CTB) to 10-pin plug harness from W7220 controller.

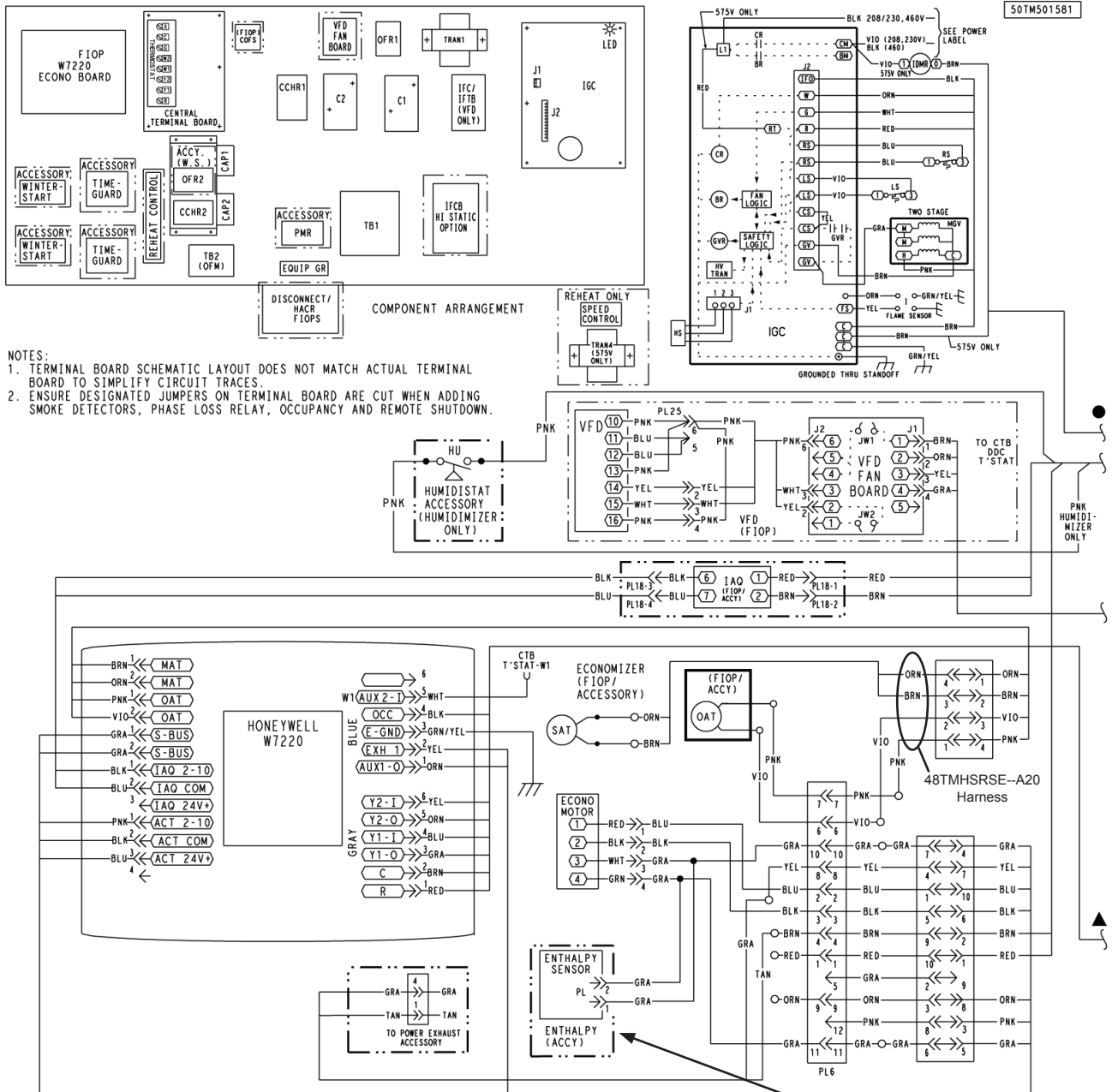

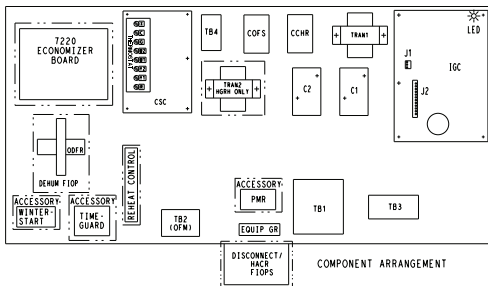

NOTES:
 1. TERMINAL BOARD SCHEMATIC LAYOUT DOES NOT MATCH ACTUAL TERMINAL BOARD TO SIMPLIFY CIRCUIT TRACES.

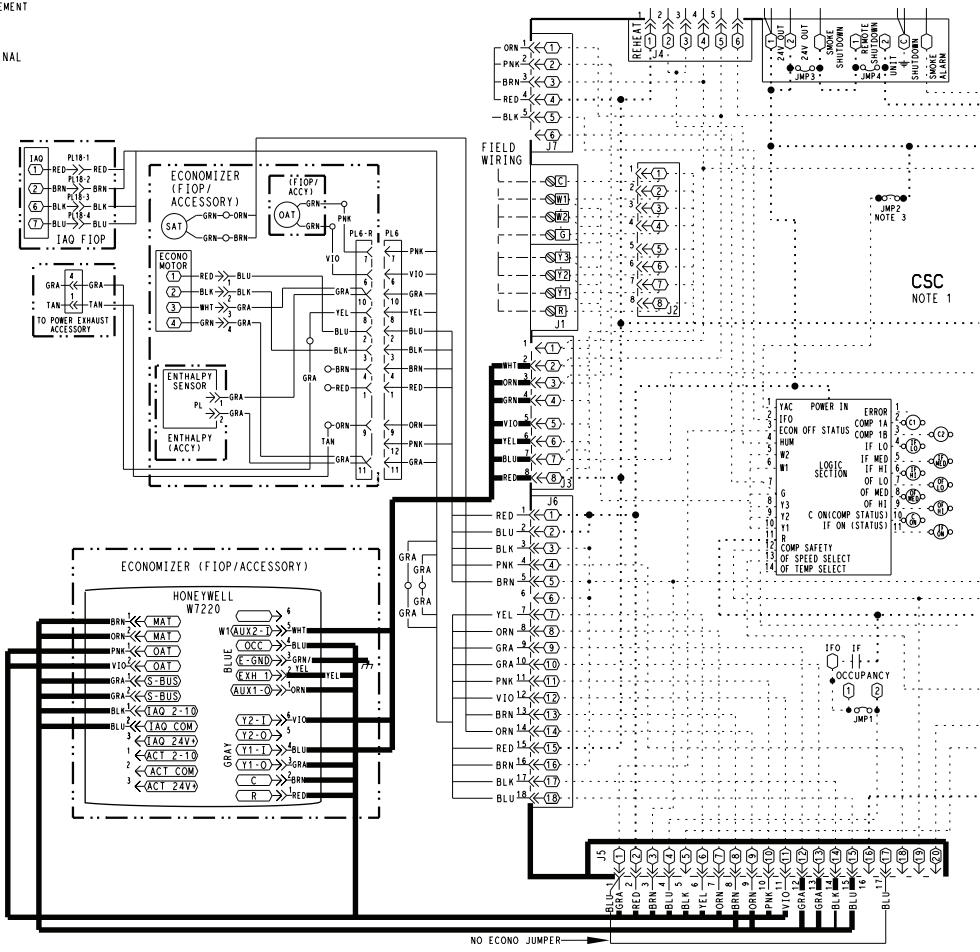

Fig. 8B - Typical EconMi\$er X Wiring Diagram For 3 Speed Units (48/50LC 07-12)
 (See 3 Speed Unit Instructions for Complete Diagram)

- NOTES:
1. Wires shown in bold are part of 48LCHSRADH--A00 harness which is provided with 48/50LC 07-12 3 speed units.
 2. Harness 48TMHARSE--A20 which is provided with economizer accessory is not used on 3 speed units.

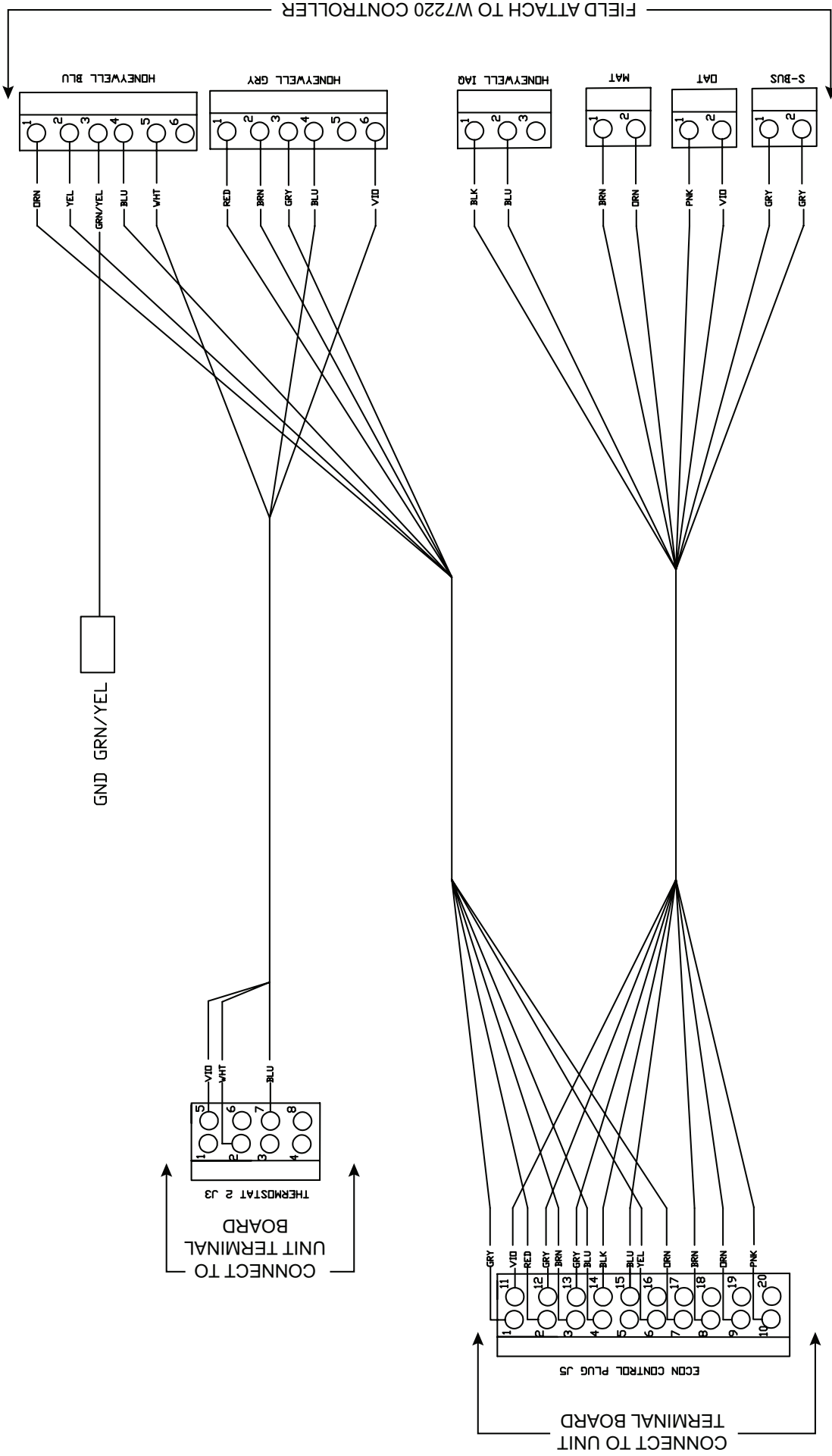

Fig. 8C - 48LCHSRADH--A00 Harness for 3 Speed Units (48/50LC 07-12)
 (Provided with 3 Speed Units, Field Attached to W7220 Controller)

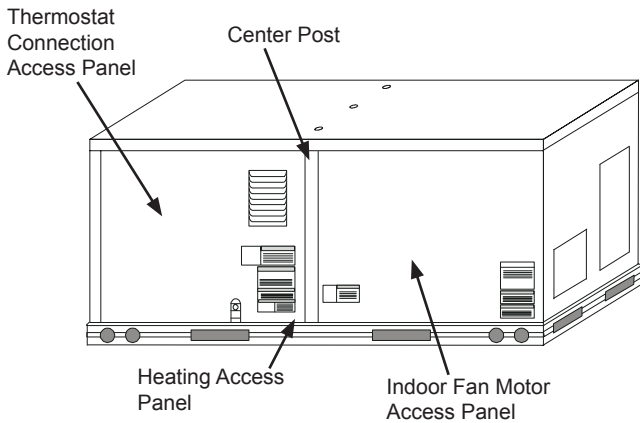

Fig. 9 - Typical Indoor Fan Motor Access Panel Locations

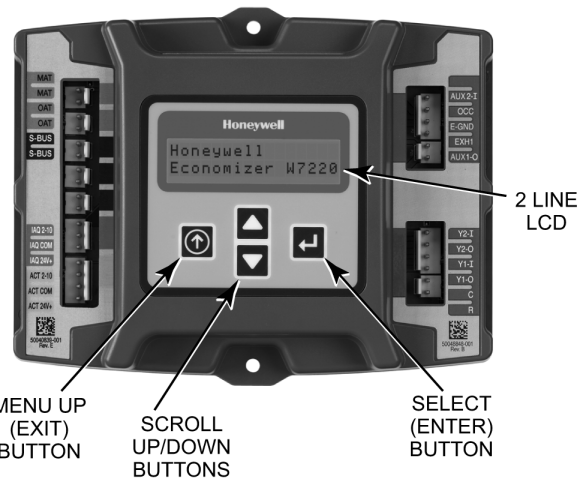

Fig. 11 - W7220 Controller

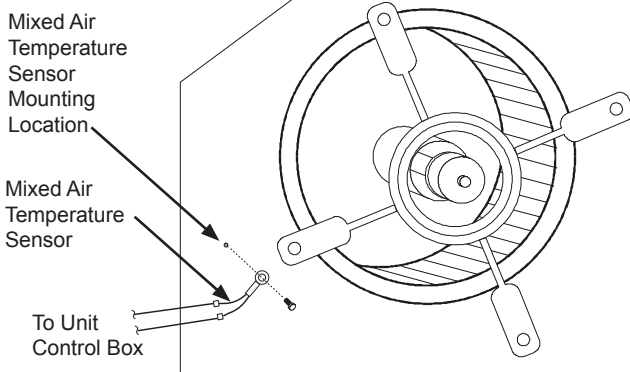

Fig. 10 - Mixed Air Sensor Placement

EconoMiSer X

The field-installed accessory consist of the following:

- Low leak economizer assembly
- W7220 economizer controller
- HH79ZZ007 Mixed (supply) air temperature sensor
- HH79ZZ007 outside air temperature air sensor
- 48TMHSRSE--A20 harness (not used on 3 speed (48/50LC 07-12) units).

W7220 Economizer

The economizer controller used on electro mechanical units is a Honeywell W7220 which is to be located in the RTU base unit's Control Box. See the Installation Instruction for your base unit for the location of the Control Box access panel.

The W7220 controller provide the following:

- 2-line LCD interface screen for setup, configuration and troubleshooting.
- On-board fault detection and diagnostics
- Sensor failure loss of communications identification
- Automatic sensor detection
- Capabilities for use with multiple-speed indoor fan systems

User Interface

The user interface consists of a LCD display and a 4-button keypad on the front of the economizer controller.

Keypad

The four navigation button (see Fig. 11) are used to scroll through the menus and menu items, select menu items, and to change parameter and configuration settings.

Using the Keypad with Menus

To use the keypad when working with menus:

- Press the ▲ (Up arrow) button to move to the previous menu.
- Press the ▼ (Down arrow) button to move to the next menu.
- Press the ↵ (Enter) button to display the first item in the currently displayed menu.
- Press the ⏪ (Menu Up/Exit) button to exit a menu's item and return to the list of menus.

Using the Keypad with Settings and Parameters

To use the keypad when working with Setpoints, System and Advanced Settings, Checkout tests and Alarms:

1. Navigate to the desire menu.
 2. Press the ↵ (Enter) button to display the first item in the currently displayed menu.
 3. Use the ▲ and ▼ buttons to scroll to the desired parameter.
 4. Press the ↵ (Enter) button to display the value of the currently displayed item.
 5. Press the ▲ button to increase (change) the displayed parameter value.
 6. Press the ▼ button to decrease (change) the displayed parameter value.
- NOTE:** When values are displayed, pressing and holding the ▲ or ▼ button causes the display to automatically increment.
7. Press the ↵ (Enter) button to accept the displayed value and store it in nonvolatile RAM.
 8. "CHANGE STORED" displays.
 9. Press the ↵ (Enter) button to return to the current menu parameter.
 10. Press the ⏪ (Menu Up/Exit) button to return to the previous menu.

Menu Structure

Table 5 illustrates the complete hierarchy of menus and parameters for the EconoMiSer X system.

The Menus in display order are:

- STATUS
- SETPOINTS
- SYSTEM SETUP
- ADVANCED SETUP
- CHECKOUT
- ALARMS

IMPORTANT NOTE: The default setting on the W7220 controller is for a "Fan Type" with 2 speed, which is correct for 2 or 3 speed units (48/50LC 07-12). If your unit is 1 (single) speed, the setting under SYSTEM SETUP > FAN TYPE must be changed to 1 speed.

IMPORTANT: Table 4 illustrates the complete hierarchy. Your menu parameters may be different depending on your configuration. For example if you do not have a DCV (CO₂) sensor, then none of the DCV parameters appear.

Table 5 – Menu Structure ^a

Menu	Parameter	Parameter Default Value	Parameter Range and Increment ^b	Notes
STATUS	ECON AVAIL	NO	YES/NO	YES = economizing available; the system can use outside air for free cooling when required
	ECONOMIZING	NO	YES/NO	YES = outside air being used for 1 st stage cooling
	OCCUPIED	NO	YES/NO	YES = OCC signal received from space thermostat or unitary controller YES = 24 Vac on terminal OCC. NO = 0 Vac on terminal OCC.
	HEAT PUMP	n/a ^c	COOL HEAT	Displays COOL or HEAT when system is set to heat pump (Non-conventional)
	COOL Y1-IN	OFF	ON/OFF	Y1-I signal from space thermostat or unitary controller for cooling stage 1. ON = 24 Vac on terminal Y1-I OFF = 0 Vac on terminal Y1-I
	COOL Y1-OUT	OFF	ON/OFF	Cool stage 1 Relay Output to stage 1 mechanical cooling (Y1-OUT terminal)
	COOL Y2-IN	OFF	ON/OFF	Y2-I signal from space thermostat our unitary controller for second stage cooling. ON = 24 Vac on terminal Y2-I OFF = 0 Vac on terminal Y2-I
	COOL Y2-OUT	OFF	ON/OFF	Cool Stage 2 Relay Output to mechanical cooling (Y2-OUT terminal)
	MA TEMP	__ . __°F	0 to 140°F	Displays value of measured mixed air from MAT sensor. Displays __ . __°F if not connected, short or out-of-range.
	DA TEMP	__ . __°F	0 to 140°F	Displays when Discharge Air sensor is connected and displays measured discharge temperature. Displays __ . __°F if sensor sends invalid value, if not connected, short or out-of-range.
	OA TEMP	__ . __°F	-40 to 140°F	Displays measured value of outdoor air temperature. Displays __ . __°F if sensor sends invalid value, short or out-of-range.
	OA HUM	__%	0 to 100%	Displays measured value of outdoor humidity from OA sensor. Displays __% if not connected short, or out-of-range.
	RA TEMP	__ . __°F	0 to 140°F	Displays measured value of return air temperature from RAT sensor. Displays __ . __°F if sensor sends invalid value, if not connected, short or out-of-range
	RA HUM	__%	0 to 100%	Displays measured value of return air humidity from RA sensor. Displays __% if sensor sends invalid value, if not connected, short or out-of-range
	IN CO2	__ __ppm	0 to 2000 ppm	Displays value of measured CO ₂ from CO ₂ sensor. Invalid if not connected, short or out-of-range
	DCV STATUS	n/a	ON/OFF	Displays ON if above setpoint and OFF if below setpoint, and ONLY if a CO ₂ sensor is connected.
	DAMPER OUT	2.0V	2.0 to 10.0V	Displays voltage output to the damper actuator.
	EXH1 OUT	OFF	ON/OFF	Output of EXH1 terminal: ON = relay closed OFF = relay open
	EXH2 OUT	OFF	ON/OFF	Output of AUX terminal; displays only if AUX = EXH2
	ERV	OFF	ON/OFF	Output of AUX terminal; displays only if AUX = ERV
MECH COOL ON	0	0,1, or 2	Displays stage of mechanical cooling that is active.	

Table 5 – Menu Structure^a (cont)

Menu	Parameter	Parameter Default Value	Parameter Range and Increment ^b	Notes
SETPOINTS	MAT SET	53°F	38 to 65°F; increment by 1	Setpoint determines where the economizer will modulate the OA damper to maintain the mixed air temperature.
	LOW T LOCK	32°F	-45 to 80°F; increment by 1	Setpoint determines outdoor temperature when the mechanical cooling cannot be turned on. Commonly referred to as the Compressor lockout.
	DRYBLB SET	63°F	48 to 80°F; increment by 1	Setpoint determines where the economizer will assume outdoor air temperature is good for free cooling; e.g.; at 63°F unit will economize at 62°F and below and not economize at 64°F and above. There is a 2°F deadband.
	ENTH CURVE	ES3	ES1,ES2,ES3,ES4, or ES5	Enthalpy boundary “curves” for economizing using single enthalpy
	DCV SET	1100ppm	500 to 2000ppm; increment by 100	Displays only if CO ₂ sensor is connected. Setpoint for Demand Control Ventilation of space. Above the setpoint, the OA dampers will modulate open to bring in additional OA to maintain a space ppm level below the setpoint.
	MIN POS	4.4 V	2 to 10 Vdc	Displays ONLY if a CO ₂ sensor is NOT connected
	VENTMAX With 2-speed fan units VENTMAX L (low speed fan) and VENTMAX H (high speed fan) settings are required	4.4 V	2 to 10 Vdc or 100 to 9990 cfm increment by 10	Displays only if a CO ₂ sensor is connected. Used for Vbz (ventilation max cfm) setpoint. Displays 2 to 10 V if <3 sensors (RA, OA, and MA). In AUTO mode dampers controlled by CFM
	VENTMAX L	6 V		
	VENTMAX H	4.4 V		
	VENTMIN With 2-speed fan units VENTMIN L (low speed fan) and VENTMIN H (high speed fan) set	2.8 V	2 to 10 Vdc or 100 to 9990 cfm increment by 10	Displays only if a CO ₂ sensor is connected. Used for Ba (ventilation min cfm) setpoint. Displays 2 to 10 V if <3 sensors (RA, OA, and MA). Va is only set if DCV is used. This is the ventilation for less than maximum occupancy of the space. In AUTO mode dampers controlled by CFM.
	VENTMIN L	3.7 V		
	VENTMIN H	2.8 V		
	ERV OAT SP	32°F	0 to 50°F; increment by 1	Only when AUX1 O = ERV
	EXH1 SET With 2-speed fan units Exh1 L (low speed fan) and Exh1 H (high speed fan) settings are required	50%	0 to 100%; increment by 1	Setpoint for OA damper position when exhaust fan 1 is powered by the economizer.
	Exh1 L	65%		
	Exh1 H	50%		
	EXH2 SET With 2-speed fan units Exh2 L (low speed fan) and Exh2 H (high speed fan) settings are required	75%	0 to 100%; increment by 1	Setpoint for OA damper position when exhaust fan 2 is powered by the economizer. Only used when AUX is set to EXH2.
	Exh2 L	80%		
	Exh2 H	75%		
	SYSTEM SETUP	INSTALL	01/01/10	
UNITS DEG		°F	°F or °C	Sets economizer controller in degrees Fahrenheit or Celsius
EQUIPMENT		CONV	Conventional or HP	CONV = conventional; HP O/B = Enable Heat Pump mode. Use AUX2 I for Heat Pump input from thermostat or controller.
AUX2 I		W	SD/W or HP(O)/HP(B)	In CONV mode: SD + Enables configuration of shutdown (default); W = Informs controller that system is in heating mode. In HP O/B mode: HP(O) = energize heat pump on Cool (default); HP(B) = energize heat pump on heat.
FAN TYPE		2 speed	1 speed/2 speed	Sets the economizer controller for operation of 1 speed or 2 speed supply fan. (Note: for 3 speed units (48/50LC 07-12), setpoint is a 2 speed.)
FAN CFM		5000cfm	100 to 15000 cfm; increment by 100	This is the capacity of the RTU. The value is found in the Project Submittal documents for the specific RTU.
AUX OUT		NONE	NONE ERV EXH2 SYS	<ul style="list-style-type: none"> NONE = not configured (output is not used) ERV = Energy Recovery Ventilatioⁿ EXH2 = second damper position relay closure for second exhaust fan SYS = use output as an alarm signal
OCC		INPUT	INPUT or ALWAYS	When using a setback thermostat with occupancy out (24 Vac), the 24 Vac is input “INPUT” to the OCC terminal. If no occupancy output from the thermostat then change program to “ALWAYS” OR add a jumper from terminal R to OCC terminal

Table 5 – Menu Structure^a (cont)

Menu	Parameter	Parameter Default Value	Parameter Range and Increment ^b	Notes
SYSTEM SETUP	FACTORY DEFAULT	NO	NO or YES	Resets all set points to factory defaults when set to YES. LCD will briefly flash YES and change to NO but all parameters will change to the factory default values.
ADVANCED SETUP	MA LO SET	45°F	35 to 55°F; Incremented by 1°	Temperature to achieve Freeze Protection (close damper and alarm if temperature falls below setup value).
	FREEZE POS	CLO	CLO or MIN	Damper position when freeze protection is active (closed or MIN POS).
	CO2 ZERO	0ppm	0 to 500 ppm; Increment by 10	CO ₂ ppm level to match CO ₂ sensor start level.
	CO2 SPAN	2000ppm	1000 to 3000 ppm; Increment by 10	CO ₂ ppm span to match CO ₂ sensor.
	STG3 DLY	2.0h	0 min, 5 min, 15 min, then 15 min intervals. Up to 4 h or OFF	Delay after stage 2 cool has been active. Turns on 2 nd stage of cooling when economizer is 1 st stage and mechanical cooling is 2 nd stage. Allows three stages of cooling, 1 economizer and 2 mechanical. OFF = no Stage 3 cooling
	SD DMPR POS	CLO	CLO or OPN	Indicates shutdown signal from space thermostat or unitary controller. When controller receives 24 Vac input on the SD terminal in conventional mode, the OA damper will open if programmed for OPN and OA damper will close if programmed for CLO. All other controls, e.g., fans, etc. will shut off.
	DCVCAL ENA	MAN	MAN (manual) AUTO	Turns on the DCV automatic control of the dampers. Resets ventilation based on the RA, OA, and MA sensor conditions. Requires all 3 RA, OA, and MA sensors.
	MAT T CAL	0.0°F	+/-2.5°F	Allows for the operator to adjust for an out of calibration temperature sensor.
	OA T CAL	0.0°F	+/-2.5°F	Allows for the operator to adjust for an out of calibration temperature sensor.
	OA H CAL	0% RH	+/-10% RH	Allows for operator to adjust for an out of calibration humidity sensor.
	RA T CAL	0.0°F	+/-2.5°F	Allows for the operator to adjust for an out of calibration temperature sensor.
	RA H CAL	0% RH	+/-10% RH	Allows for operator to adjust for an out of calibration humidity sensor.
	DA T CA;	0.0°F	+/-2.5°F	Allows for the operator to adjust for an out of calibration temperature sensor.
CHECKOUT	DAMPER VMIN—HS	n/a	n/a	Positions damper to VMIN position
	DAMPER VMAX—HS	n/a	n/a	Positions damper to VMAX position
	DAMPER OPEN	n/a	n/a	Position damper to the full open position. Exhaust fan contacts enable during the DAMPER OPEN test. Make sure you pause in the mode to allow exhaust contacts to energize due to the delay in the system.
	DAMPER CLOSE	n/a	n/a	Positions damper to the fully closed position
	CONNECT Y1—O	n/a	n/a	Closes the Y1—O relay (Y1—O)
	CONNECT Y2—O	n/a	n/a	Closes the Y2—O relay (Y2—O)
	CONNECT AUX	n/a	n/a	Energizes the AUX output. If Aux setting is: • NONE – not action taken • ERV – 24 Vac out. Turns on or signals an ERV that the conditions are not good for economizing but are for ERV operation. ^d • SYS – 24 Vac out. Issues a system alarm
ALARMS(#)				Alarms display only when they are active. The menu title “ALARMS(#)” includes the number of active alarms in parenthesis (). When using SYLK bus sensors, “SYLK” will appear on the screen, and when using 20k OA temperature sensors, “SENS T” will appear on the screen
	MA T SENS ERR	n/a	n/a	Mixed air sensor has failed or become disconnected - check wiring then replace sensor if the alarm continues.
	CO2 SENS ERR	n/a	n/a	CO2 sensor has failed, gone out of range or become disconnected - check wiring then replace sensor if the alarm continues.
	OA SYLK T ERR	n/a	n/a	Outdoor air enthalpy sensor has failed or become disconnected - check wiring then replace sensor if the alarm continues.
	OA SYLK H ERR	n/a	n/a	Outdoor air enthalpy sensor has failed or become disconnected - check wiring then replace sensor if the alarm continues.
	RA SYLK T ERR	n/a	n/a	Return air enthalpy sensor has failed or become disconnected - check wiring then replace sensor if the alarm continues.
	RA SYLK H ERR	n/a	n/a	Return air enthalpy sensor has failed or become disconnected - check wiring then replace sensor if the alarm continues.
	DA SYLK T ERR	n/a	n/a	Discharge air sensor has failed or become disconnected - check wiring then replace sensor if the alarm continues
OA SENS T ERR			Outdoor air temperature sensor has failed or become disconnected - check wiring then replace if the alarm continues.	

Table 5 – Menu Structure^a (cont)

Menu	Parameter	Parameter Default Value	Parameter Range and Increment ^b	Notes
ALARMS(#) CONTINUED	ACT ERROR	n/a	n/a	Actuator has failed or become disconnected - check for stall, over voltage, undervoltage and actuator count. Replace actuator if damper is moveable and supply voltage is between 21.6 V and 26.4 V. Check actuator count on STATUS menu
	FREEZE ALARM	n/a	n/a	Check if outdoor temperature is below the LOW Temp Lockout on setpoint menu. Check if Mixed air temperature on STATUS menu is below the Lo Setpoint on Advanced menu. When conditions are back in normal range then the alarm will go away.
	SHUTDOWN ACTIVE	n/a	n/a	AUX2 IN is programmed for SHUTDOWN and 24 V has been applied to AUX 2IN terminal.
	DMP CAL RUNNING	n/a	n/a	If DCV Auto enable has been programmed, when the Jade is completing a calibration on the dampers, this alarm will display. Wait until the calibration is completed and the alarm will go away. Must have OA, MA and RA sensors for DCV calibration; set up in the Advanced setup menu.
	DA SENS ALM	n/a	n/a	Discharge air temperature is out of the range set in the ADVANCED SETUP Menu. Check the temperature of the discharge air.
	SYS ALARM	n/a	n/a	When AUX1-0 is set to SYS and there is any alarm (e.g., failed sensors, etc.), the AUX1-0 terminal has 24 Vac out.
	ACT UNDER V	n/a	n/a	Voltage received by Actuator is above expected range.
	ACT OVER V	n/a	n/a	Voltage received by Actuator is below expected range.
ACT STALLED	n/a	n/a	Actuator stopped before achieving commanded position.	

^a Table 5 illustrates the complete hierarchy. Your menu parameters may be different depending on your configuration. For example if you do not have a DCV (CO₂) sensor, then none of the DCV parameters appear

^b When values are displayed, pressing and holding the ▲ or ▼ button causes the display to automatically increment.

^c n/a = not applicable

^d ERV Operation: When in Cooling mode AND the conditions are NOT OK for economizing - the ERV terminal will be energized. In the Heating mode the ERV terminal will be energized when the OA is below the ERV OAT setpoint in the setpoint menu.

Checkout Tests

Use the Checkout menu (see Table 5) to test the damper operation and any configured outputs. Only items that are configured are shown in the Checkout menu.

NOTE: See User Interface on page 3 for information about menu navigation and use of the keypad.

To perform a Checkout test:

1. Scroll to the desired test in the Checkout menu using the ▲ and ▼ buttons.
2. Press the ↵ button to select the item.
3. RUN? appears.
4. Press the ↵ button to start the test.
5. The unit pauses and then displays IN PROGRESS.
6. When the test is complete, DONE appears.
7. When all desired parameters have been tested, press the ⏮ (Menu up) button to end the test.

Checkout test can be performed at any time during the operation of the system as a test that the system is operable.

⚠ CAUTION

EQUIPMENT DAMAGE HAZARD

Failure to follow this caution may result in damage to equipment

Be sure to allow enough time for compressor startup and shutdown between checkout tests so that you do not short-cycle the compressors.

SETUP AND CONFIGURATION

W7220 Economizer Module Wiring

Use Fig. 12 and Tables 6 and 7 to locate the wiring terminals for the economizer module.

NOTE: The four terminal blocks are removable. You can slide out each terminal block, wire it, and then slide it back into place.

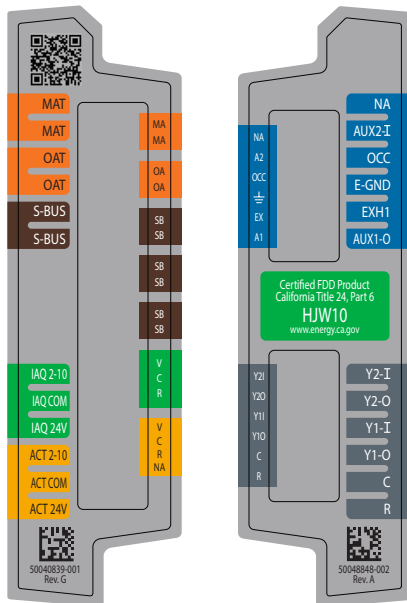

Fig. 12 - W7220 Economizer Module Terminal Connection Labels

Table 6 - Economizer Module - Left Hand Terminal Blocks

Label	Type	Description
Top Left Terminal Block		
MAT MAT	20k NTC and COM	Mixed Air Temperature Sensor (Polarity insensitive connections)
OAT OAT	20k NTC and COM	Outdoor Air Temperature Sensor (Polarity insensitive connection)
S-BUS S-BUS	S-BUS (Syk Bus)	Enthalpy Control Sensor (Polarity insensitive connection)
Bottom Left Terminal Block		
IAQ 2-10	2-10 Vdc	Air Quality Sensor Input (e.g. CO ₂ sensor)
IAQ COM	COM	Air Quality Sensor Common
IAQ 24V	24 Vac	Air Quality Sensor 24 Vac Source
ACT 2-10	2-10 Vdc	Damper Actuator Output (2-10 Vdc)
ACT COM	COM	Damper Actuator Output Common
ACT 24V	24 Vac	Damper Actuator 24 Vac Source

Table 7 - Economizer Module - Right Hand Terminal Blocks

Label	Type	Description
Top Right Terminal Block		
	n/a	The first terminal is not used
AUX2 I	24 Vac IN	Shut Down (SD) or Heat (W) Conventional only and Heat Pump Changeover (O?B) in Heat Pump mode.
OCC	24 Vac IN	Occupied / Unoccupied Input
E - GND	E-GND	Earth Ground - System Required
EXH1	24 Vac OUT	Exhaust Fan 1 Output
AUX1 O	24 Vac OUT	Programmable: Exhaust fan 2 output or ERV or System alarm output
Bottom Right Terminal Block		
Y2-1	24 Vac IN	Y2 in - Cooling Stage 2 Input from space thermostat
Y2-O	24 Vac OUT	Y2 out - Cooling Stage 2 Output to stage 2 mechanical cooling
Y1-I	24 Vac IN	Y1 in - Cooling Stage 2 Input from space thermostat
Y1-O	24 Vac OUT	Y1 out - Cooling Stage 2 Output to stage 2 mechanical cooling
C	COM	24 Vac Common
R	24 Vac	24 Vac Power (Hot)

Time-out and Screen Saver

When no buttons have been pressed for 10 minutes, the LCD displays a screen saver, which cycles through the Status items. Each Status item displays in turn and cycles to the next item after 5 seconds.

HH79ZZ007 Dry Bulb Sensor

Economizers are shipped standard with an HH79ZZ007 outside air dry bulb sensor, which looks like an eyelet terminal with 2 green wires. This sensor is factory installed on the front of the economizer in the outside air stream. System default setting (high temp limit) is 63 degrees F, and has a range of 48 to 80 degrees F. Note: a 2nd HH79ZZ007 sensor is provided for mixed (supply) air temperature.

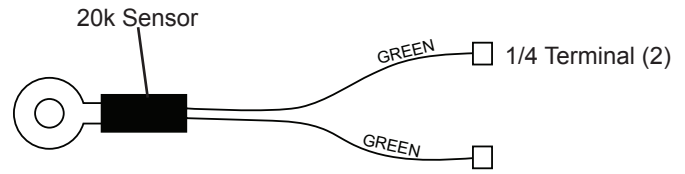

Fig. 12A - HH79ZZ007 Sensor

Device Type ^a	Climate Zones	Required High Limit (Economizer Off When):
		Description
Fixed Dry Bulb	1, 3, 5, 11-16	Outdoor air temperature exceeds 75°F
	2, 4, 10	Outside air temperature exceeds 73°F
	6, 8, 9	Outdoor air temperature exceeds 71°F
	7	Outdoor air temperature exceeds 69°F
Differential Dry Bulb	1, 3, 5, 11-16	Outdoor air temperature exceeds return air temperature
	2, 4, 10	Outdoor air temperature exceeds return air temperature minus 2°F
	6, 8, 9	Outdoor air temperature exceeds return air temperature minus 4°F
	7	Outdoor air temperature exceeds return air temperature minus 6°F
Fixed Enthalpy ^b + Fixed Dry Bulb	All	Outdoor air enthalpy exceeds 28 Btu/lb of dry air ^b or Outdoor air temperature exceeds 75°F

^a Only the high limit control devices listed are allowed to be used and at the setpoints listed. Others such as Dew Point, Fixed Enthalpy, Electronic Enthalpy, and Differential Enthalpy Controls, may not be used in any climate zone for compliance with Section 140.4(e)1 unless approval for use is provided by the Energy Commission Executive Director.

^b At altitudes substantially different than sea level, the Fixed Enthalpy limit value shall be set to the enthalpy value at 75°F and 50% relative humidity. As an example, at approximately 6,000 foot elevation, the fixed enthalpy limit is approximately 30.7 Btu/lb.

Table 8 - California Title 24 Regional High Limit Dry Bulb Temperature Settings
TABLE 140.4-B AIR ECONOMIZER HIGH LIMIT SHUT OFF CONTROL REQUIREMENTS

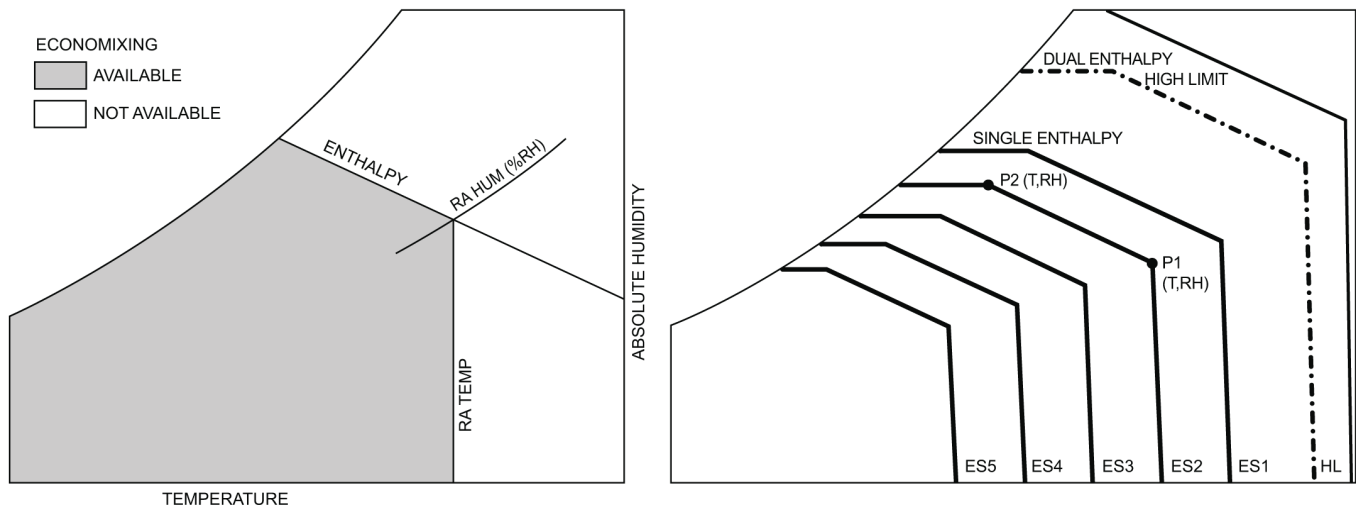

Fig. 13 - Single Enthalpy Curve boundaries

Table 9 - Single Enthalpy and Dual Enthalpy High Limit Curves

Enthalpy Curve	Temp. Dry Bulb (°F)	Temp. Dewpoint (°F)	Enthalpy (btu/lb/da)	Point P1		Point P2	
				Temp (°F)	Humidity %RH	Temp (°F)	Humidity %RH
ES1	80.0	60.0	28.0	80.0	36.8	66.3	80.1
ES2	75.0	57.0	26.0	75.0	39.6	63.3	80.0
ES3	70.0	54.0	24.0	70.0	42.3	59.7	81.4
ES4	65.0	51.0	22.0	65.0	44.8	55.7	84.2
ES5	60.0	48.0	20.0	60.0	46.9	51.3	88.5
HL	86.0	66.0	32.4	86.0	38.9	72.4	80.3

Enthalpy Settings (Optional Accessory)

If installing the optional HH57AC081 enthalpy sensor. The HH79AH001 dry bulb outside air sensor must first be removed. Wire enthalpy to S-BUS connections on W7220 controller thru (2) gray wires.

When the OA temperature, enthalpy and dew point are below the respective setpoints, the Outdoor Air can be used for economizing. Fig. 13 shows the new single enthalpy boundaries in the W7220. There are 5 boundaries (setpoints ES1 thru ES5), which are defined by dry bulb temperature, enthalpy and dew point.

Refer to Table 9 for ENTH CURVE setpoint values.

To use enthalpy the W7220 must have a HH57AC081 enthalpy control sensor for OA. The W7220 calculates the enthalpy and dewpoint using the OA temperature and humidity input from the OA sensor. When the OA temperature, OA humidity and OA dew point are all below the selected boundary, the economizer sets the economizing mode to YES, economizing is available.

When all of the OA conditions are above the selected boundary, the conditions are not good to economize and the mode is set to NO.

Fig. 13 shows the 5 current boundaries. There is also a high limit boundary for differential enthalpy. The high limit boundary is ES1 when there are no stages of mechanical cooling energized and HL (high limit) when a compressor stage is energized.

Table 8 provided the values for each boundary limit.

If using OA enthalpy sensor HH57AC081 accessory, remove and discard the dry bulb sensor shipped with the economizer. System enthalpy default is ES3 curve.

See Table 8 for California Title 24 high limit settings.

Enthalpy control Sensor Configuration

The optional Enthalpy Control sensor (Part Number: HH57AC081) communicates with the W7220 Economizer controller on the two-wire communications bus and can either be wired using a two pin header or using a side connector. This sensor can be used for outdoor enthalpy, or indoor dry bulb or enthalpy depending on the dip-switch setting. System enthalpy default is ES3 curve. See Table 8 for California Title 24 high limit settings.

Use Fig. 14 and Table 10 to locate the wiring terminals for each Enthalpy Control sensor.

Use Fig. 14 and Table 11 to set the DIP switches for the desired use of the sensor.

If using differential (return) enthalpy or temperature, see Table 8 for California Title 24 setting requirements by region.

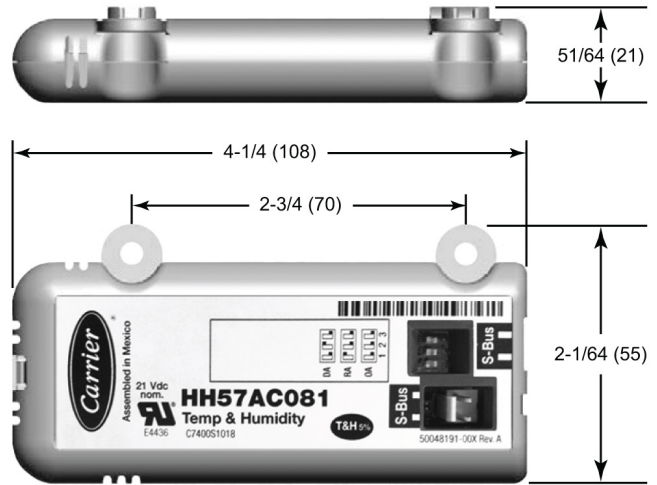

NOTE: Dimensions in () are in mm

Fig. 14 - HH57AC081 Accessory (Used for Outdoor Enthalpy, or Indoor Return Temperature or Enthalpy)

Table 10 - HH57AC081 Sensor Wiring Terminations^a

Terminal		Type	Description
Nbr	Label		
1	S-BUS	S-BUS	S-Bus Communications (Enthalpy Control Sensor Bus)
2	S-BUS	S-BUS	S-Bus Communications (Enthalpy Control Sensor Bus)

Table 11 - HH57AC081 Sensor DIP Switch

Use	DIP Switch Positions for Switches 1, 2, & 3		
	1	2	3
DA ^a	OFF	ON	OFF
RA ^b	ON	OFF	OFF
OA ^c	OFF	OFF	OFF

a DA = Discharge Air or Supply Sensor

b RA = Return Air

c OA = Outside Air

OPERATION

Cooling, Unit with EconoMiSer X

For Occupied mode operation of EconoMiSer X, there must be a 24-v signal at terminals R and OCC (provided through PL6-3 from the unit's IFC coil). Removing the signal at OCC places the EconoMiSer X control in Unoccupied mode.

During Occupied mode operation, indoor fan operation will be accompanied by economizer dampers moving to Minimum Position setpoint for ventilation. If indoor fan is off, dampers will close. During Unoccupied mode operation, dampers will remain closed unless a Cooling (by free cooling) or DCV demand is received.

When free cooling using outside air is not available, the unit cooling sequence will be controlled directly by the space thermostat. Outside air damper position will be closed or Minimum Position as determined by Occupancy mode and fan signal.

When free cooling is available as determined by the appropriate changeover command (dry bulb, outdoor enthalpy, differential dry bulb or differential enthalpy), a call for cooling (Y1 closes at the thermostat) will cause the economizer control to modulate the dampers open and closed to maintain the unit supply air temperature. Default supply air temperature is 53°F, with a range of 38° to 70°F. Compressor will not run.

Should 100% outside air not be capable of satisfying the space temperature, space temperature will rise until Y2 is closed. The economizer control will call for compressor operation. Dampers will modulate to maintain SAT at setpoint concurrent with Compressor 1 operation. The "Low T Temp" setting (default 32°F) will lock out compressor operation.

When space temperature demand is satisfied (thermostat Y1 opens), the dampers will return to Minimum Damper position if indoor fan is running or fully closed if fan is off.

If accessory power exhaust is installed, the power exhaust fan motors will be energized by the economizer control as the dampers open above the EXH1 SET setpoint and will be-energized as the dampers close below the EXH1 SET setpoint.

Damper movement from full closed to full open (or vice versa) will take between 1-1/2 and 2-1/2 minutes.

Heating with EconoMiSer X

During Occupied mode operation, indoor fan operation will be accompanied by economizer dampers moving to Minimum Position setpoint for ventilation. If indoor fan is off, dampers will close. During Unoccupied mode operation, dampers will remain closed unless a DCV demand is received.

When the room temperature calls for heat (W1 closes), the heating controls are energized.

Demand Controlled Ventilation

If a field-installed CO₂ sensor is connected to the EconoMiSer X control, a Demand controlled Ventilation strategy will operate automatically. As the CO₂ level in the space increases above the setpoint (on the EconoMiSer X controller), the minimum position of the dampers will be increased proportionally, until the Maximum Ventilation setting is reached. As the space CO₂ level decreases because of the increase in fresh air, the outdoor damper will follow the higher demand condition from the DCV mode or from the free cooling mode.

DCV operation is available in Occupied and Unoccupied periods with EconoMiSer X. However, a control modification will be required on the units to implement the Unoccupied period function.

Table 12 - Damper Position Control, 2-Speed Fan Motor, Economizer Cooling Not Available

INPUT					
OCC	0 - V	24 - V	24 - V	24 - V	24 - V
Y1	0 - V	0 - V	24 - V	24 - V	0 - V
Y2	0 - V	0 - V	0 - V	24 - V	0 - V
W1	0 - V	0 - V	0 - V	0 - V	24 - V
SUPPLY FAN MOTOR SPEED	OFF	LOW	LOW	HIGH	HIGH
DAMPER POSITION					
NO CO ₂ SENSOR	CLOSED	MIN POS	MIN POS	MIN POS	MIN POS
W/ CO ₂ SENSOR	CLOSED	FROM VENTMIN L TO VENTMAX L	FROM VENTMIN L TO VENTMAX L	FROM VENTMIN H TO VENTMAX H	FROM VENTMIN H TO VENTMAX H

TROUBLESHOOTING

Power Loss (Outage or Brownout)

All setpoints and advanced settings are restored after any power loss or interruption, as all settings are stored in the Economizer controller's non-volatile flash memory.

NOTE If the power goes below 18 Vac, the W7220 controller module assumes a power loss and the 5 minute power up delay will become functional when power returns above 18 Vac.

Alarms

The Economizer module provides alarm messages that display on the 2-line LCD

NOTE: Upon power up, the module waits several seconds before checking for alarms. This allows time for all the configured devices (e.g. sensors, actuator) to become operational.

If one or more alarms are present and there has been no keypad activity for at least 5 minutes, the Alarms menu displays and cycles through the active alarms.

You can also navigate to the Alarms menus at any time.

See Table 5 for the Alarms menu.

Clearing Alarms

Once the alarm has been identified and the cause has been removed (e.g. replaced faulty sensor). The can be cleared from the display.

To clear an alarm, perform the following:

1. Navigate to the desired alarm.
2. Press the \leftarrow button.
3. ERASE? displays.
4. Press the \leftarrow button.
5. ALARM ERASED displays.
6. Press the \uparrow (Menu up/Exit) button to complete the action and return to the previous menu.

NOTE: If the alarm still exists after you clear it, it is redisplayed within 5 seconds.

Table 13 - Operating Issues and Concerns

Issue or Concern	Possible Cause and Remedy
My outdoor temperature reading on the STATUS menu is not accurate	Check the sensor wiring: <ul style="list-style-type: none"> • Enthalpy sensors are to be wired to the S-Bus terminals. • Temperature sensors are to be wired to the OAT and MAT terminals.
If my enthalpy sensor drifts in accuracy over time, can I re-calibrate it?	The sensor is not able to be re-calibrated in the field. However there is a menu item under the ADVANCED menu where you are able to input a limited off set in temperature and humidity for each sensor you have connected to the economizer.
Can I go back to factory defaults and start over?	Under the SYSTEM SETUP menu you can change the setpoints to the factory defaults.
Will I be able to see the LCD screen when it is in the unit?	The LCD screen has a backlight that is always illuminated.
What is a good setpoint for the Mixed Air Temperature (MAT)?	The mixed are temperature is the temperature of air that you want to supply to the space. In a commercial building, this is between 50 to 55°F (10 to 13°C). The mixed are is the mixing of the return air and the outdoor air.
I am using enthalpy sensors. Why did the control ask me to input a dry bulb changeover temperature?	In the even the humidity sensor in the enthalpy sensors fails, the backup algorithm in the control is to default to the temperature sensor in the enthalpy sensor.
In checkout, the outdoor damper closes when I command it to open.	Check the actuator linkage or rotation. In the CHECKOUT mode, the outdoor damper should drive open or closed with the return air damper having the opposite effect.
How do I set my minimum position?	The minimum position is set using the VENTMIN and VENTMAX setup in the SETPOINTS menu. VENTMIN is the minimum ventilation required when using an occupancy sensor and VENTMAX is the minimum ventilation when not using an occupancy sensor for Demand Control Ventilation. The VENTMAX position is set the dame as with the potentiometer on the analog economizers and is the output voltage to the damper actuator. The range is 2 Vdc closed OA damper and 10 Vdc open OA damper.
What if my damper does not go completely closed in the checkout operation?	Check the damper linkage or hub to make sure the damper is able to close completely.
How do I set the OCC?	There are two setting for the OCC setting, INPUT and ALWAYS, INPUT is from the space thermostat, if it has an occupancy output. ALWAYS is the unit in the occupied mode, if the economizer is powered (fan on).
Does the economizer save my program values if the unit loses power?	Yes, once the changes are stored in the controller they will be stored until they are changed by the operator.
If the unit is left in checkout, how long will the unit stay in checkout mode without input?	The unit will remain in checkout for 10 minutes, then return to normal operation.

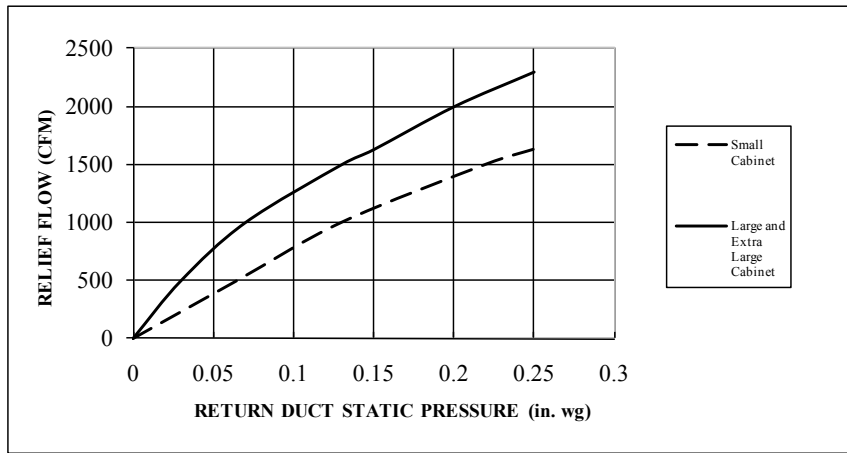

Fig. 15 - Barometric Relief Flow Capacity

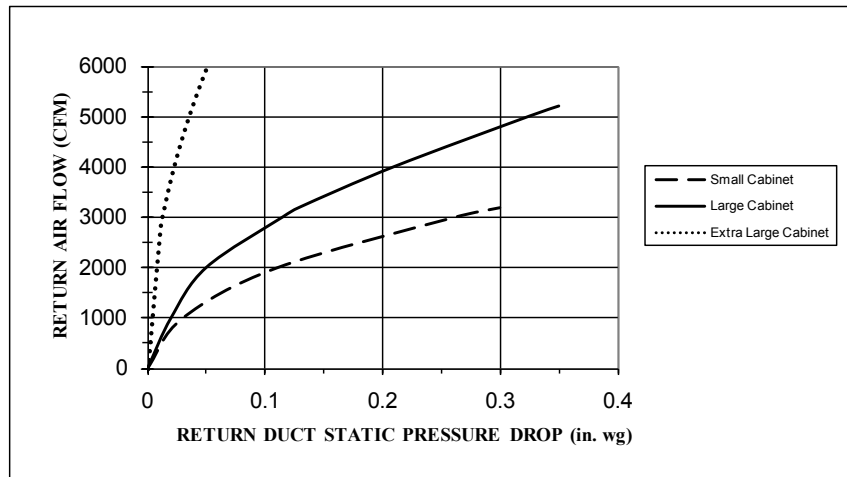

Fig. 16 - Return Air Pressure Drop