

SPECIFICATIONS

FIGURE 7005P HANGERS



STANDARD DUTY ADJUSTABLE CLEVIS HANGERS

FEATURES

- Finish: plain
- Color: black

PRODUCT SPECIFICATIONS

Standards

- Design - MSS SP-58, Type 1
- Federal specification - WW-H-171, Type 1

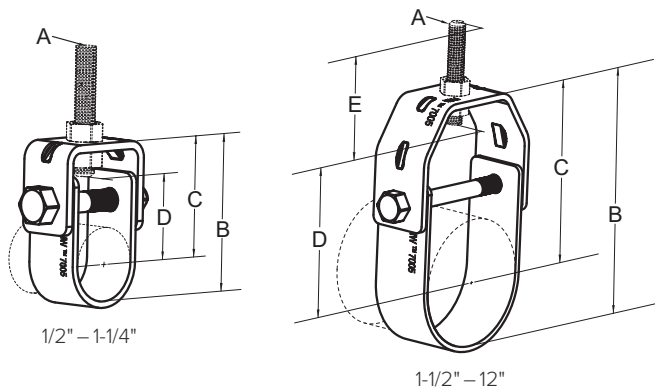

FIGURE 7005P

HANGERS



STANDARD DUTY ADJUSTABLE CLEVIS HANGERS



Note: A - rod size (hanger rod and nuts not included); B - bottom of pipe to top of hanger; C - center of pipe to top of hanger; D - rod take out (center of pipe to bottom of hanger rod); E - minimum thread length of hanger rod; F - adjustment, top of cross bolt to bottom of hanger

DIMENSIONS

Catalog Number	Pipe Size		A Rod Size	B		C		D	
	in.	mm		in.	mm	in.	mm	in.	mm
FNW7005P0050	1/2	21.3	3/8"-16	2.05	52	1.61	41	0.98	25
FNW7005P0075	3/4	26.7	3/8"-16	2.32	59	1.77	45	1.14	29
FNW7005P0100	1	33.4	3/8"-16	2.64	67	1.97	50	1.34	34
FNW7005P0125	1-1/4	42.2	3/8"-16	3.23	82	2.40	61	1.77	45
FNW7005P0150	1-1/2	48.3	3/8"-16	3.86	98	2.87	73	2.24	57
FNW7005P0200	2	60.3	3/8"-16	4.41	112	3.23	82	2.60	66
FNW7005P0250	2-1/2	73.0	1/2"-13	5.12	130	3.62	92	2.80	71
FNW7005P0300	3	88.9	1/2"-13	5.87	149	4.13	105	3.31	84
FNW7005P0400	4	114.3	5/8"-11	7.64	194	5.39	137	4.33	110
FNW7005P0500	5	141.3	5/8"-11	9.59	243.5	6.81	173	5.69	144.5
FNW7005P0600	6	168.3	3/4"-10	11.56	293.5	8.23	209	6.87	174.5
FNW7005P0800	8	219.1	3/4"-10	13.88	352.5	9.53	242	8.17	207.5
FNW7005P1000	10	273.0	7/8"-9	16.93	430	11.46	291	10.00	254
FNW7005P1200	12	323.9	7/8"-9	19.76	502	13.27	337	11.73	298

Catalog Number	Pipe Size		E		F		Bolt Size	Design Load		Weight	
	in.	mm	in.	mm	in.	mm		lbs	kN	lbs	kg
FNW7005P0050	1/2	21.3	2.50	63.5	0.45	11.5	1/4"-20UNC	610	2.71	0.15	0.07
FNW7005P0075	3/4	26.7	2.50	63.5	0.51	13	1/4"-20UNC	610	2.71	0.18	0.08
FNW7005P0100	1	33.4	2.50	63.5	0.55	14	1/4"-20UNC	729	3.24	0.20	0.09
FNW7005P0125	1-1/4	42.2	2.50	63.5	0.83	21	1/4"-20UNC	729	3.24	0.24	0.11
FNW7005P0150	1-1/2	48.3	2.50	63.5	1.18	30	1/4"-20UNC	729	3.24	0.26	0.12
FNW7005P0200	2	60.3	2.50	63.5	1.18	30	1/4"-20UNC	729	3.24	0.31	0.14
FNW7005P0250	2-1/2	73.0	2.50	63.5	0.98	25	3/8"-16UNC	1350	6	0.82	0.37
FNW7005P0300	3	88.9	2.50	63.5	1.22	31	3/8"-16UNC	1350	6	0.93	0.42
FNW7005P0400	4	114.3	2.50	63.5	1.73	44	3/8"-16UNC	1431	6.36	1.30	0.59
FNW7005P0500	5	141.3	2.50	63.5	2.36	60	1/2"-13UNC	1431	6.36	2.25	1.02
FNW7005P0600	6	168.3	3.00	76.2	3.07	78	1/2"-13UNC	1942	8.63	3.26	1.48
FNW7005P0800	8	219.1	3.50	88.9	3.07	78	5/8"-11UNC	2000	8.89	4.92	2.23
FNW7005P1000	10	273.0	3.50	88.9	3.31	84	3/4"-10UNC	3600	16	8.82	4
FNW7005P1200	12	323.9	3.50	88.9	3.98	101	3/4"-10UNC	3803	16.9	11.74	5.323

SPECIFICATIONS

FIGURE 7005P HANGERS



STANDARD DUTY LARGE DIAMETER ADJUSTABLE CLEVIS HANGER

FEATURES

- Finish: plain
- Color: black

PRODUCT SPECIFICATIONS

Standards

- Design - MSS SP-58, Type 1
- Federal specification - WW-H-171, Type 1

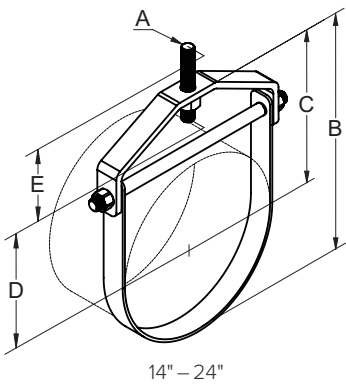

Note: A - rod size (hanger rod and nuts not included); B - bottom of pipe to top of hanger; C - center of pipe to top of hanger; D - rod take out (center of pipe to bottom of hanger rod); E - minimum thread length of hanger rod; F - adjustment, top of cross bolt to bottom of hanger

DIMENSIONS

Catalog Number	Pipe Size		A Rod Size	B		C		D	
	in.	mm		in.	mm	in.	mm	in.	mm
FNW7005P1400	14	355.6	7/8"-9	21.65	550	14.49	368	12.83	326
FNW7005P1600	16	406.4	1-1/8"-7	24.49	622	16.34	415	14.29	363
FNW7005P1800	18	457.0	1-1/8"-7	27.28	693	17.99	457	15.94	405
FNW7005P2000	20	508.0	1-1/8"-7	29.65	753	19.41	493	17.36	441
FNW7005P2400	24	610.0	1-1/8"-7	35.94	913	23.82	605	21.61	549

Catalog Number	Pipe Size		E		F		Bolt Size	Design Load		Weight	
	in.	mm	in.	mm	in.	mm		lbs	kN	lbs	kg
FNW7005P1400	14	355.6	2.87	73.0	4.33	102	7/8"-9UNC	4185	18.6	13.89	6.3
FNW7005P1600	16	406.4	3.37	85.7	5.12	114	7/8"-9UNC	4590	20.4	23.81	10.8
FNW7005P1800	18	457.0	3.37	85.7	5.79	130	7/8"-9UNC	4793	21.3	25.57	11.6
FNW7005P2000	20	508.0	4.81	122.2	6.22	141	7/8"-9UNC	4793	21.3	32.19	14.6
FNW7005P2400	24	610.0	5.25	133.3	7.56	176	1-1/8"-7UNC	4793	21.3	51.81	23.5