



# SERVICE PARTS LIST

**BULLETIN NO.**  
**54-47-0210**

SPECIFY CATALOG NO. AND SERIAL NO. WHEN ORDERING PARTS		REVISED BULLETIN	DATE
<b>18 Volt PEX Expander</b>			Nov. 2013
CATALOG NO.	<b>2632-20</b>	STARTING SERIAL NO.	<b>C67A</b>
		WIRING INSTRUCTION <b>SEE PAGE 2</b>	

**EXAMPLE:**  
Component Parts (Small #)  
Are Included When Ordering  
The Assembly (Large #).

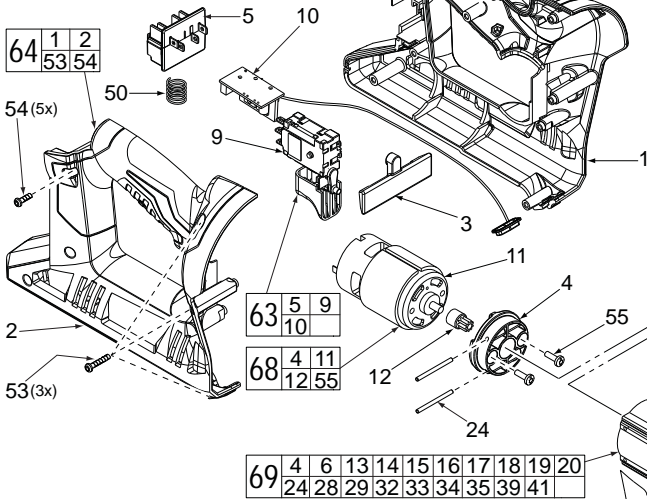

FIG.	PART NO.	DESCRIPTION OF PART	NO. REQ.
50	40-50-1090	Terminal Block Spring	(1)
51	06-82-5346	8-32 x .75 Pan Hd. Tapt. T-20 Screw	(2)
52	06-82-5362	8-32 x 1" Pan Hd. Tapt. T-20 Screw	(4)
53	05-88-1710	M3.5 x 22mm Pan Hd. T-10 Screw	(3)
54	06-82-2025	M3.5 x 16mm Pan Hd. T-10 Screw	(5)
55	-----	M4 x 8mm Pan Hd. Screw	(2)
59	12-20-2632	Service Nameplate	(1)
63	23-66-2935	Switch Assembly	(1)
64	31-44-3200	Handle Assembly	(1)
65	14-30-1100	Gearcase	(1)
66	14-29-0550	Cam Gear Assembly	(1)

FIG.	PART NO.	DESCRIPTION OF PART	NO. REQ.
1	-----	Handle Halve - Left	(1)
2	-----	Handle Halve - Right	(1)
3	31-76-0450	Lockout Shuttle	(1)
4	-----	Motor Mount Bracket	(1)
5	22-56-1350	Terminal Block	(1)
6	-----	Gearcase Support	(1)
7	-----	Gearcase Cover	(1)
8	28-28-1010	Diaphragm	(1)
9	-----	Switch	(1)
10	-----	PCBA	(1)
11	-----	Motor	(1)
12	-----	Motor Pinion	(1)
13	-----	1st and 2nd Ring Gear	(1)
14	-----	1st and 2nd Planet Gear	(6)
15	-----	1st Carrier and 2nd Sun Gear	(1)
16	-----	3rd Ring Gear	(1)
17	-----	2nd Carrier and 3rd Sun Gear	(1)
18	-----	3rd Planet Gear	(4)
19	-----	3rd Carrier	(1)
20	-----	4th Pinion	(1)
21	32-75-3550	Idle Gear	(1)
22	-----	4th Drive Gear	(1)
23	-----	Cam	(1)
24	44-60-1970	Motor Mount Pin	(2)
25	44-60-1580	Shuttle Pin	(1)
26	44-96-0260	Roller	(1)
27	44-66-2180	Roller Pin	(1)
28	-----	Diaphragm Pin	(2)
29	-----	Idle Gear Pin	(1)
30	02-50-1240	Needle Bearing	(1)
31	-----	Needle Bearing	(1)
32	-----	Needle Bearing	(1)
33	02-04-0390	Ball Bearing	(1)
34	-----	Ball Bearing	(1)
35	-----	Spacer	(1)
36	31-76-0300	Drive Collar	(1)
37	42-76-0890	Rotating Collar	(1)
38	43-40-1000	Frame	(1)
39	-----	Washer	(1)
40	45-88-3090	Washer	(1)
41	-----	Retaining Ring	(1)
42	32-75-1590	Spindle	(1)
43	34-40-0490	O-Ring	(1)
44	-----	Ring	(1)
45	-----	Segment	(6)
46	-----	Big Spring for Head	(1)
47	-----	Small Spring for Head	(1)
48	40-50-1575	Collar Spring	(1)
49	40-50-1640	Spindle Returning Spring	(1)

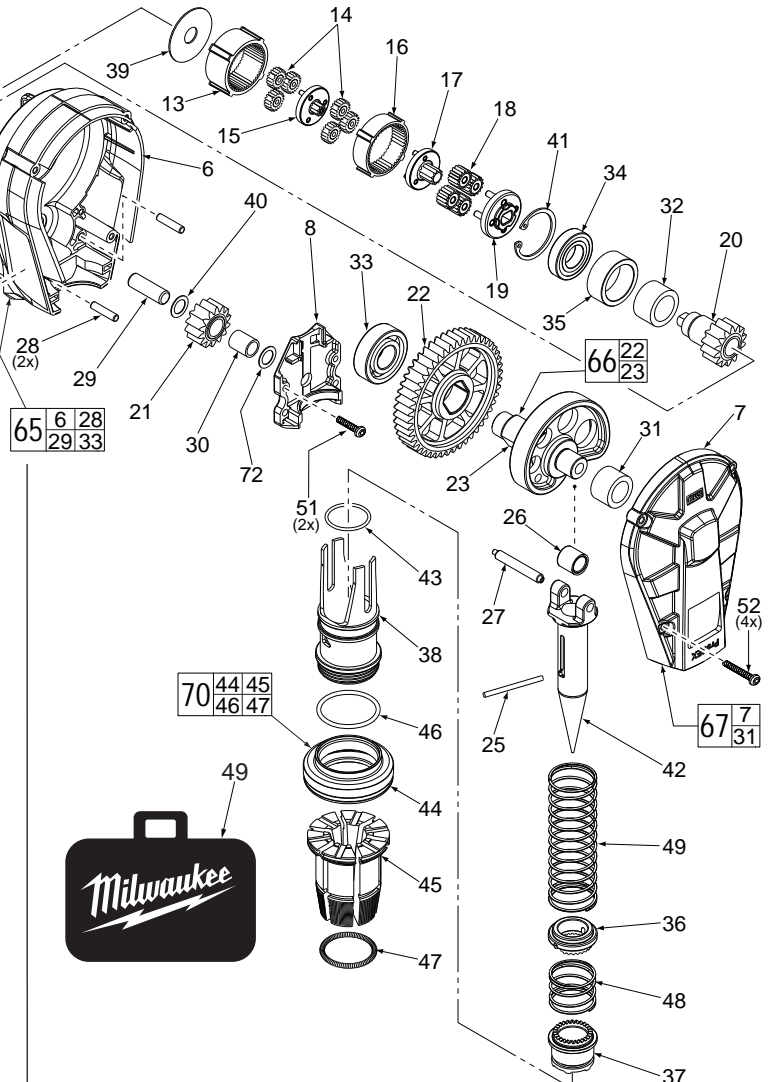
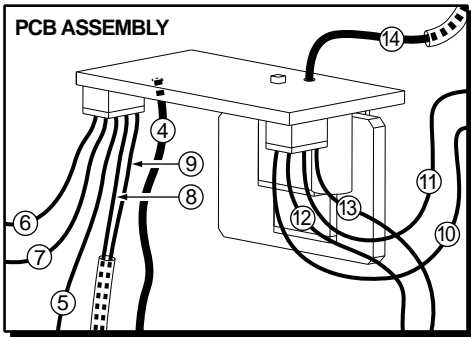
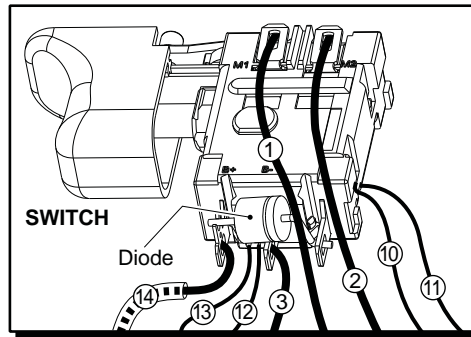

FIG.	PART NO.	DESCRIPTION OF PART	NO. REQ.
67	14-38-0900	Gearcase Cover Assembly	(1)
68	23-30-0925	Motor Assembly	(1)
69	14-29-0625	Gearcase Assembly	(1)
70	49-16-2608	H1" Head Assembly	(1)
71	42-55-2600	Carrying Case, Optional	(1)
72	45-88-0688	Washer	(1)

**FIG. 4,68,69 NOTES:**  
Service replacement gearcase assembly (69) comes with a motor mount plate (4) that must be removed and discarded when servicing. A motor mount plate already exists on the motor assembly (68).



Blue wire #14 and LED wires #8 & #9 are captured within insulating sleeves



AS AN AID TO REASSEMBLY, TAKE NOTICE OF WIRE ROUTING AND POSITION IN WIRE GUIDES AND TRAPS WHILE DISMANTLING TOOL

BE CAREFUL AND AVOID PINCHING WIRES BETWEEN HANDLE HALVES! WHEN ASSEMBLING.

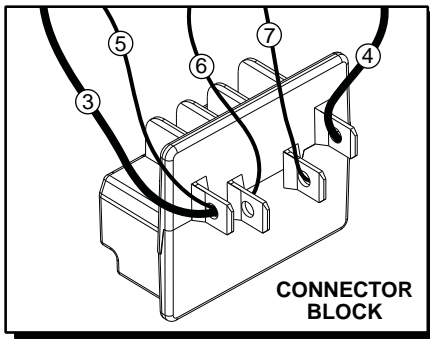

CONNECTOR BLOCK

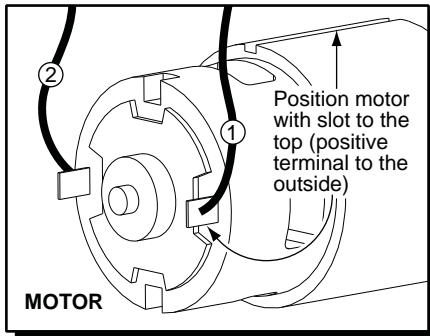

MOTOR

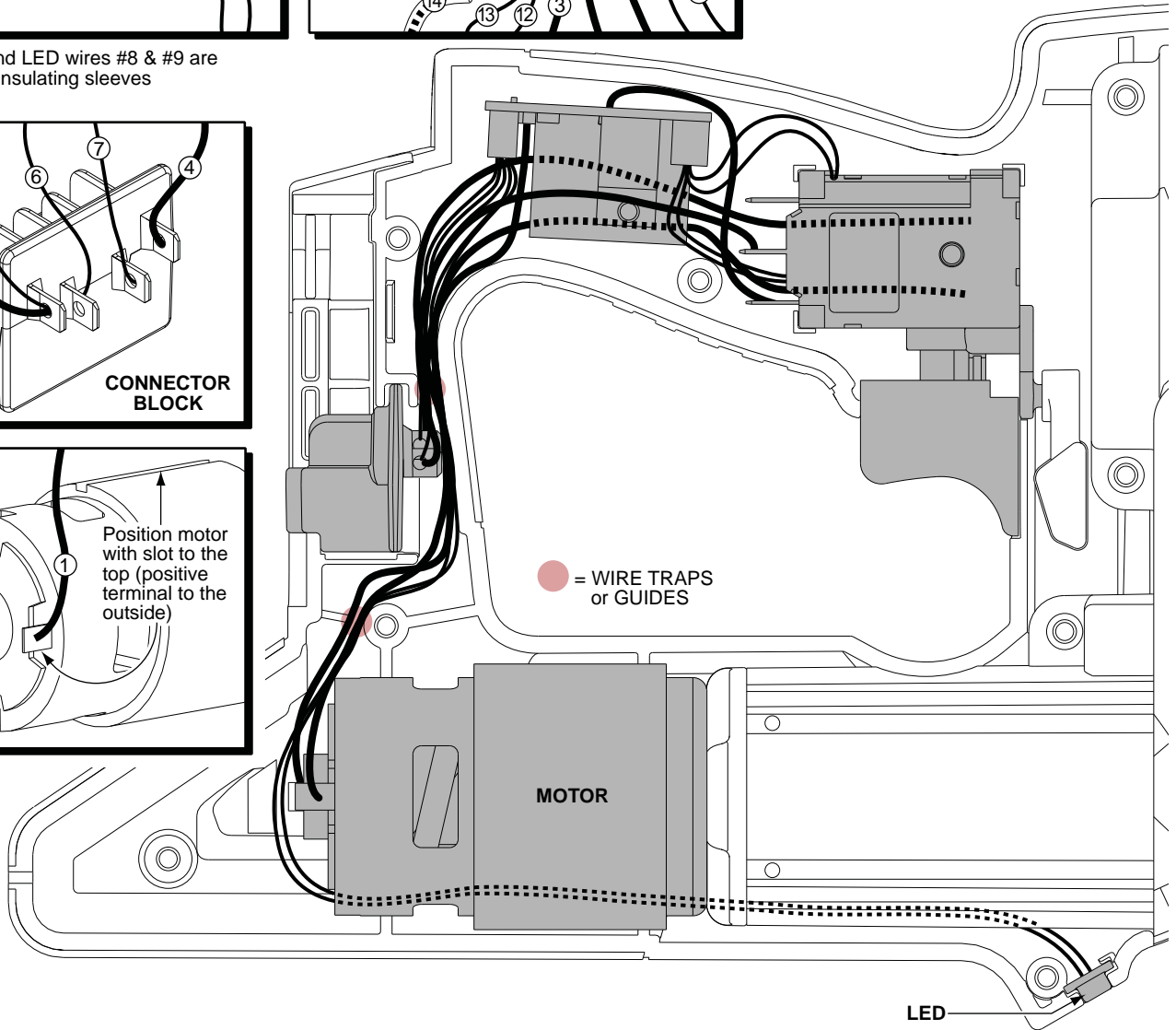

MOTOR

● = WIRE TRAPS or GUIDES

LED

### WIRING SPECIFICATIONS

Wire No.	Wire Color	Origin or Gauge	Length	Terminals, Connectors and 1 or 2 End Wire Preparation
1	Red	----	----	Connect to the positive terminal on motor and 'M1' on switch.
2	Black	----	----	Connect to the negative terminal on motor and 'M2' on switch.
3	Red	23-66-2935	----	Component of the switch assembly. Attached to connector block and switch.
4	Black	23-66-2935	----	Component of the switch assembly. Attached to connector block and PCB assembly.
5	Red	23-66-2935	----	Part of the switch assy. One of a 5 wire harness that plugs into PCB assy. Other end soldered with #3 to connector block.
6	Blue	23-66-2935	----	Part of the switch assy. One of a 5 wire harness that plugs into PCB assy. Other end soldered to connector block.
7	Black	23-66-2935	----	Part of the switch assy. One of a 5 wire harness that plugs into PCB assy. Other end soldered to connector block.
8	Blue	23-66-2935	----	Component of the switch assy. Wires #8 and #9 are part of a 5 wire harness that plugs into the PCB assy. #8 and #9 are sleeved together and connect to the LED at the other end.
9	Yellow	23-66-2935	----	
10	Orange	23-66-2935	----	Part of the switch assy. One of a 4 wire harness that plugs into PCB assy. Other end attached to the switch.
11	White	23-66-2935	----	Part of the switch assy. One of a 4 wire harness that plugs into PCB assy. Other end attached to the switch.
12	Green	23-66-2935	----	Part of the switch assy. One of a 4 wire harness that plugs into PCB assy. Other end attached to the switch.
13	Brown	23-66-2935	----	Part of the switch assy. One of a 4 wire harness that plugs into PCB assy. Other end attached to the switch.
14	Blue	23-66-2935	----	Component of the switch assembly. Attached to switch and PCB assembly.