

Commercial 3/8" Outlet Hammer Arrestor Valve, Metal Dishwasher and Ice Maker Outlet Box with Drain

Left Hand Drain Option

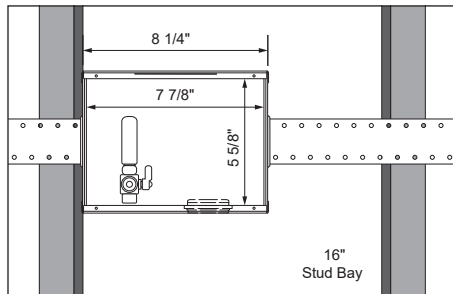

Right Hand Drain Option

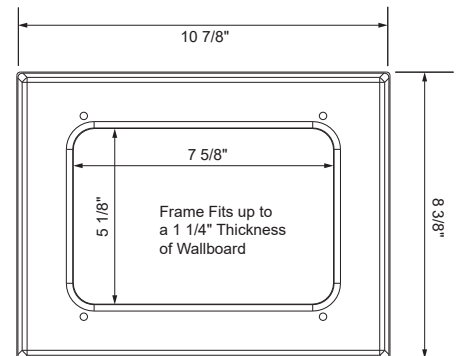
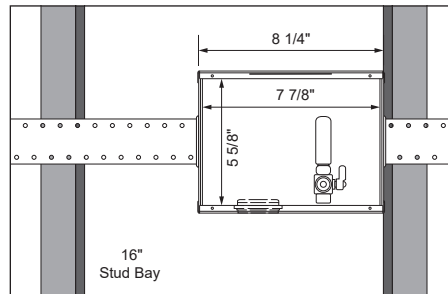

RMDW1AB Commercial Ice Maker/Dishwasher/Coffee Maker Box Installation

- 1) Remove the faceplate that is attached to the outlet box and save for future installation once sheet rock has been completed.
- 2) Using either nails or screws, mount the box to the stud.
- 3) Box can be mounted on either side of the stud bay.
- 4) Make sure the drain in the outlet box is above the water level of the Ice Maker/Dishwasher/Coffee Maker it is draining.
- 5) Connect 2" threaded pipe nipple or male adapter (PVC or ABS) to the drain hole in the box using the Slipnut Drain Kit. Connect appropriate pipe to the drain fitting used. Confirm with local codes regarding need for P-trap installation below outlet box.
- 6) Connect the water supply piping to the outlet box valves using appropriate piping for valve connections. Check all local codes.
- 7) Test all piping joints for leaks. Test drain line if required by local code.
- 8) After sheet rock has been installed, screw the faceplate onto the outlet box.
- 9) To the 3/8" outlet of valve attach either:
 - a) Copper supply tubing via compression connection.
 - b) Poly supply tubing via compression connection - brass insert into poly tube is required
 - c) Braided hose via threaded connection.
- 10) Connect to the inlet connection of the commercial ice maker, dishwasher, or coffee maker.
- 11) Make sure drain hose is secured so it does not push out of the box due to the water being forced out of the hose from the Ice Maker/Dishwasher/Coffee Maker.
- 12) Check all local codes for appropriate approvals and requirements.

Part #	Replacement Component Description	Qty
88300	3/8" Lead Free Qtr Turn 1/2" Solder Valve w/HA 1	
89917	Locknut for Solder Valve	1
90193	Valve Spacer	1
90504	Faceplate	1
89893	Faceplate Screws (#8x1 1/4) - Package of 4	1
90505	Mounting Brackets	2

Part #	Replacement Component Description	Qty
97031	7/8" Rubber Washers for Valve	1
97032	3/4" & 1/2" Reducing Washers for Valve	1
97034	2" CP Slipnuts for Drain	1
97036	2" Rubber Gaskets for Drain	1
97046	2" Flange Nuts for Drain	1

Item #	Replacement Component Description	Model #	Case Qty	Packaging
88436	Brass Qtr Turn Hammer Arrestor Valve, Uninstalled, 1/2" Sweat Conx. with 3/8" Compression Outlet and 2" Slipnut Drain Kit - Standard Packaging.	RMDW1AB	5	Standard Pack