



Evergreen[®]

CONDENSING GAS BOILER
70/110/155

Boiler Manual

- Installation
- Maintenance
- Startup
- Parts



This manual must only be used by a qualified heating installer/service technician. Read all instructions, including this manual and all other information shipped with the boiler, before installing. Perform steps in the order given. Failure to comply could result in severe personal injury, death or substantial property damage.

Part number 550-100-191/0619



Contents

The Evergreen® Gas-fired water boilers 2
 Please read before proceeding 7
 Boiler location 8
 Prepare boiler location 10
 Wall-mounting the boiler 10
 Boiler hydrostatic test 13
 Converting boiler to propane — EVG 70 15
 Converting boiler to propane — EVG 110 17
 Converting boiler to propane — EVG 155 19
 Gas piping — sizing gas lines 21
 Venting/air piping — general 22
 Commonwealth of Massachusetts installations 25
 Vent termination requirements 26
 Boiler room air openings 27
 DIRECT VENT — Sidewall with separate pipes 28
 DIRECT VENT — Sidewall concentric 30
 DIRECT VENT — Sidewall with W-M vent/air plate 32
 DIRECT VENT — Vertical with separate pipes 34
 DIRECT VENT — Vertical concentric 36
 DIRECT VENT — Vertical vent /sidewall air 38
 Concentric termination, typical (sidewall or vertical) 40
 Vent and air piping and boiler connections 41
 Install water piping 42
 Direct Connect System Piping - Single Boiler System 43
 Verify the application will work: 43
 Expansion tank location 43
 Diaphragm- or bladder-type tank: 43
 Closed-type expansion tank: 44
 System water piping methods 45
 Install relief valve 45
 ZONE VALVE zoning – direct connection 46
 Primary/Secondary System Piping - Single Boiler System See
 Advanced Manual for Multiple Boiler Systems 47
 Expansion tank location 47
 Diaphragm- or bladder-type tank: 47
 Closed-type expansion tank 47
 System water piping methods 48
 Install relief valve 49
 ZONE VALVE zoning – primary/secondary 50
 Circulator zoning – primary/secondary 51
 Circulator zoning – Multiple temperature zones with primary/secondary 52
 Install condensate line 53
 Gas piping 54

⚠ WARNING DO NOT SERVICE THE BOILER WITHOUT AN Evergreen® MAINTENANCE KIT AVAILABLE

The maintenance kit includes components that may have to be replaced when accessing or disassembling parts of the boiler. Failure to replace damaged components and to use only the parts specifically intended for the boiler can result in severe personal injury, death or substantial property damage. See Figure 111, page 127 for part number.

Field wiring 55
 Wiring diagram — schematic 63
 Wiring diagram — ladder 64
 Zoning with the EVG Control 65
 Evergreen control operation 67
 EVG control settings menus 71
 EXPRESS SETUP — Example A 72
 EXPRESS SETUP — Example B 74
 EXPRESS SETUP — Example C 76
 Available control settings and system presets 78
 CONTRACTOR menus 79
 BOILER SETTINGS menu, BASIC mode 80
 PRIORITY 1, 2, 3 menus, BASIC mode 81
 ASSIGN INPUTS menu, BASIC mode 82
 DIAGNOSTIC menu 84
 MAINTENANCE, DATE AND TIME menus 89
 Startup — fill the system 91
 Startup — final checks 93
 Check-out/startup verification 99
 Annual startup and general maintenance 100
 Annual startup 101
 Troubleshooting 107
 Maintenance 115
 Cleaning heat exchanger flue side, 70 117
 Cleaning heat exchanger flue side, 110 120
 Cleaning heat exchanger flue side, 155 123
 Replacement parts 126
 Dimensions 138
 Ratings — Evergreen® boilers 139
 Installation and Service Certificate 141
 Evergreen® Gas Boiler Data Collection Sheet 144

Hazard definitions

The following defined terms are used throughout this manual to bring attention to the presence of hazards of various risk levels or to important information concerning the life of the product.

⚠ DANGER Indicates presence of hazards that will cause severe personal injury, death OR substantial property damage.

⚠ WARNING Indicates presence of hazards that can cause severe personal injury, death or substantial property damage.

⚠ CAUTION Indicates presence of hazards that will or can cause minor personal injury or property damage.

NOTICE Indicates special instructions on installation, operation or maintenance that are important but not related to personal injury or property damage.



The Evergreen® Gas-fired water boilers

1. Stainless steel firetube heat exchanger

2. Heat exchanger access cover/burner mounting plate

3. Blower

The advanced blower design and air inlet silencer on Evergreen® boilers result in very quiet operation.

Air enters the boiler enclosure through the air intake adapter (Item 19), flows through the enclosure, enters the air inlet silencer (Item 5), then enters the venturi (Item 6) where it mixes with gas before entering the blower. The blower pulls air through these components and then pushes it through the cover plate to the burner (Item 12).

4. Gas valve

The automatic gas valve references the pressure in the cabinet and allows gas to flow when the control (Item 16) applies power. A manual gas shut off valve is shipped loose with the boiler. It allows shutting off the gas supply for servicing or shut down. See instructions in this manual for manual gas valve installation.

5. Air inlet silencer

The horn-shaped air inlet silencer significantly reduces fan noise, providing exceptionally quiet operation.

6. Venturi

When air flows through the venturi, a negative pressure is created. This causes gas to flow from the gas valve into the venturi, where it is mixed with the air. The gas/air mixture then continues into the blower.

7. Supply water temperature dual sensor

This dual sensor monitors boiler outlet water temperature. The control adjusts boiler firing rate so the outlet water temperature is correct, based on the calculated (if outdoor reset used — see page 139) or fixed target temperature.

8. Return water temperature sensor

This sensor monitors return water temperature to the boiler. The control reduces or increases boiler input, depending on how close the return water temperature is to the outlet water temperature.

9. Electronic display & buttons

The electronic display is used to configure boiler settings and monitor boiler operation. The buttons allow changing display mode, selecting and adjusting control settings, and resetting the control after lockout.

10. Flue adapter (fits 3" PVC)

11. Flue pipe

12. Burner (not shown)

Made with high-grade stainless steel construction, the burner uses pre-mixed air and gas. The burner and control provide modulating firing.

13. Water outlet pipe (system supply)

14. Water inlet pipe (system return)

15. Gas line

This stainless steel flexible gas line connects the incoming gas line to the gas valve. The gas line has a ½" NPT connection for installation.

16. Control module (see discussion upper right)

17. Communication Board

The communication board provides boiler-to-boiler communication and Building Management System (BMS) interface.

18. Boiler circulator terminal block

19. Air intake adapter (fits 3" PVC)

20a. Electrical entrances (line voltage)

The top left side knockouts are designated for line voltage wiring only. Ensure all wiring entrances are sealed.

20b. Electrical entrances (low voltage)

The bottom left side knockouts are designated for low voltage wiring only. Ensure all wiring entrances are sealed.

20c. Electrical entrance (multiple boiler communication)

The top right knockout (1) is designated for multiple boiler communication and BMS wiring. Ensure all wiring entrances are sealed.

21. Boiler drain valve (not shown)

Shipped loose for field piping. Pipe drain valve on reducing tee at the lowest point of return piping to boiler. See instructions, page 14 in this manual.

22. Condensate trap nozzle

The outlet at the bottom of the condensate collection dish. This is where condensate is discharged from the boiler. The condensate trap assembly attaches here.

Evergreen® control overview

- The Evergreen® control can operate a single boiler or coordinate with other Evergreen® boilers in a multiple boiler system.
- Control inputs and outputs allow operation of multiple heating circuits (space heating and DHW, for example).
- Up to three priority levels can be set, providing automatic switch-over on demand.
- This manual provides quick set-up information for single boiler installations.
- The Advanced Manual, also supplied with the boiler, provides instructions for setting up multiple-boiler systems and for using advanced options for single boilers.

Evergreen® control operation

- The control responds to signals from the room thermostats, DHW aquastats (if used), boiler sensors (boiler return, boiler supply, flue temperature), outdoor temperature and system sensors, if used.
- The control automatically adjusts blower speed (and gas flow rate) to match boiler output to space heating and/or DHW heating demand.
- The default control settings provide for three space heating zones. The control can be easily set up for operation with a DHW zone, with or without domestic priority.

Evergreen® control WIZARD

- The control setup Wizard is available from the BOILER SETTINGS menu that appears during initial startup.
- The Wizard leads through a step-by-step setup procedure designed for the application chosen.
- Context-sensitive help is available to explain the purpose of key setup items.

23. Flue gas condensate drain trap assembly and bracket

The condensate trap assembly and bracket are field-installed, condensate drain trap is connected to the condensate trap nozzle as shown in this manual.

24. Jacket door

The jacket door is sealed to the boiler assembly around its entire perimeter.

25. Front door latches

Two (2) latches secure the door in place.

26. Door retention screw

27. Ignition electrode/flame sensor

The burner flame is ignited by applying a high voltage to the ignition electrode. This causes a spark (from electrode to ground). After ignition, the electrode measures flame signal.

28. Flame inspection window

The quartz glass window provides a view of the burner surface, the flame, and the ignition electrode.

29. Flue gas dual sensor

This dual sensor monitors the flue gas exit temperature. The Evergreen® control will shut down the boiler if flue gas temperature gets too hot. This protects the flue pipe and the heat exchanger from overheating.

30. Gas valve reference hose (EVG-70 only)

This rubber line connects the gas valve diaphragm reference chamber to the venturi intake to insure the valve senses the correct reference pressure.

31. Transformer

The 120V/24V transformer provides 24V to low voltage control circuitry. Do NOT splice wiring into transformer.

32. Air baffle

The air baffle protects internal boiler components by diverting any incoming moisture or debris away from critical components. It must be temporarily removed while servicing the heat exchanger.

33. Floor stand assembly

The provided stand allows for the Evergreen® boiler to be either wall hung or floor standing.



The EVG-70 Gas-fired water boilers

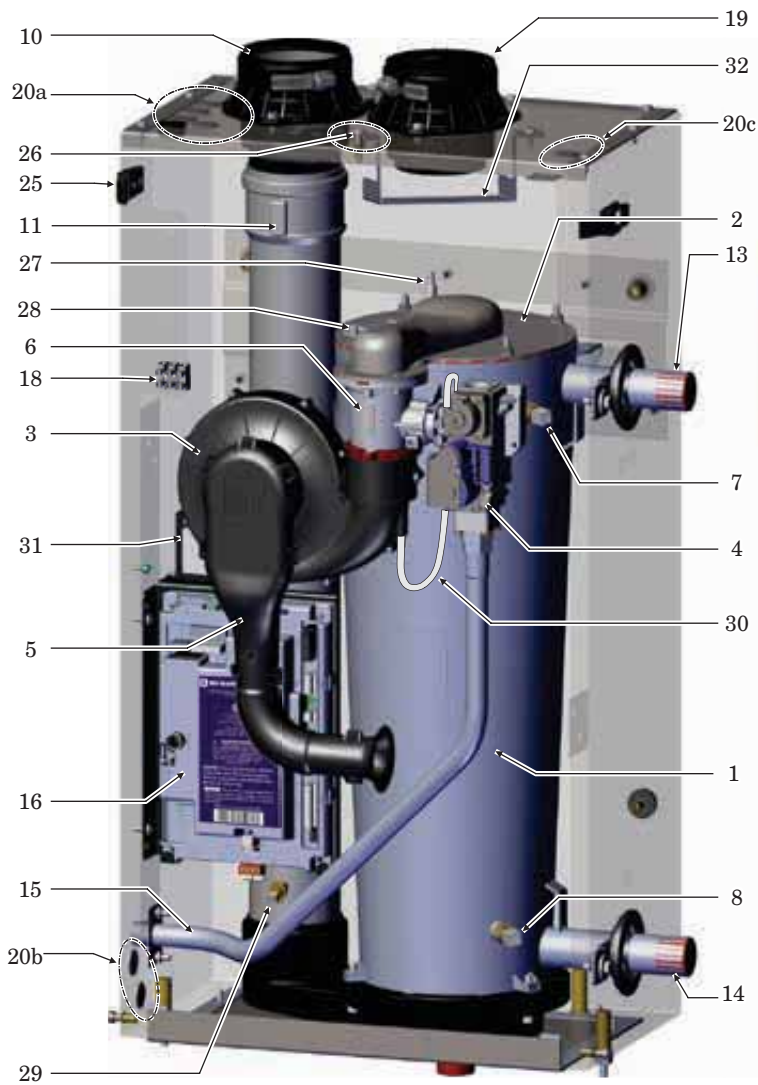

EVG-70 Interior
(some components omitted for clarity)

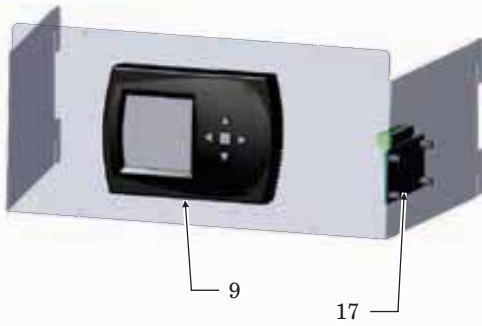

Evergreen Front



Evergreen Bottom

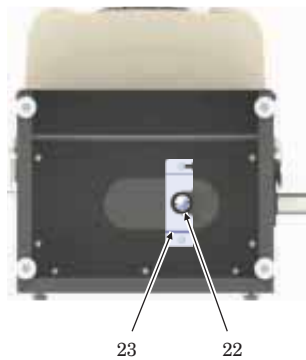

EVG-003-70

Evergreen Top

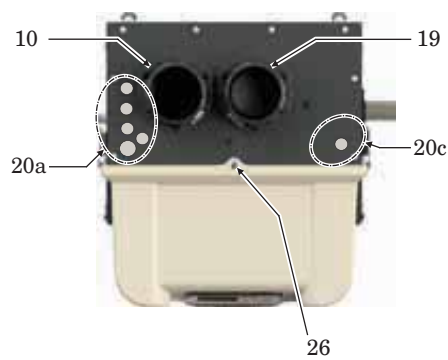



The EVG-110 Gas-fired water boilers

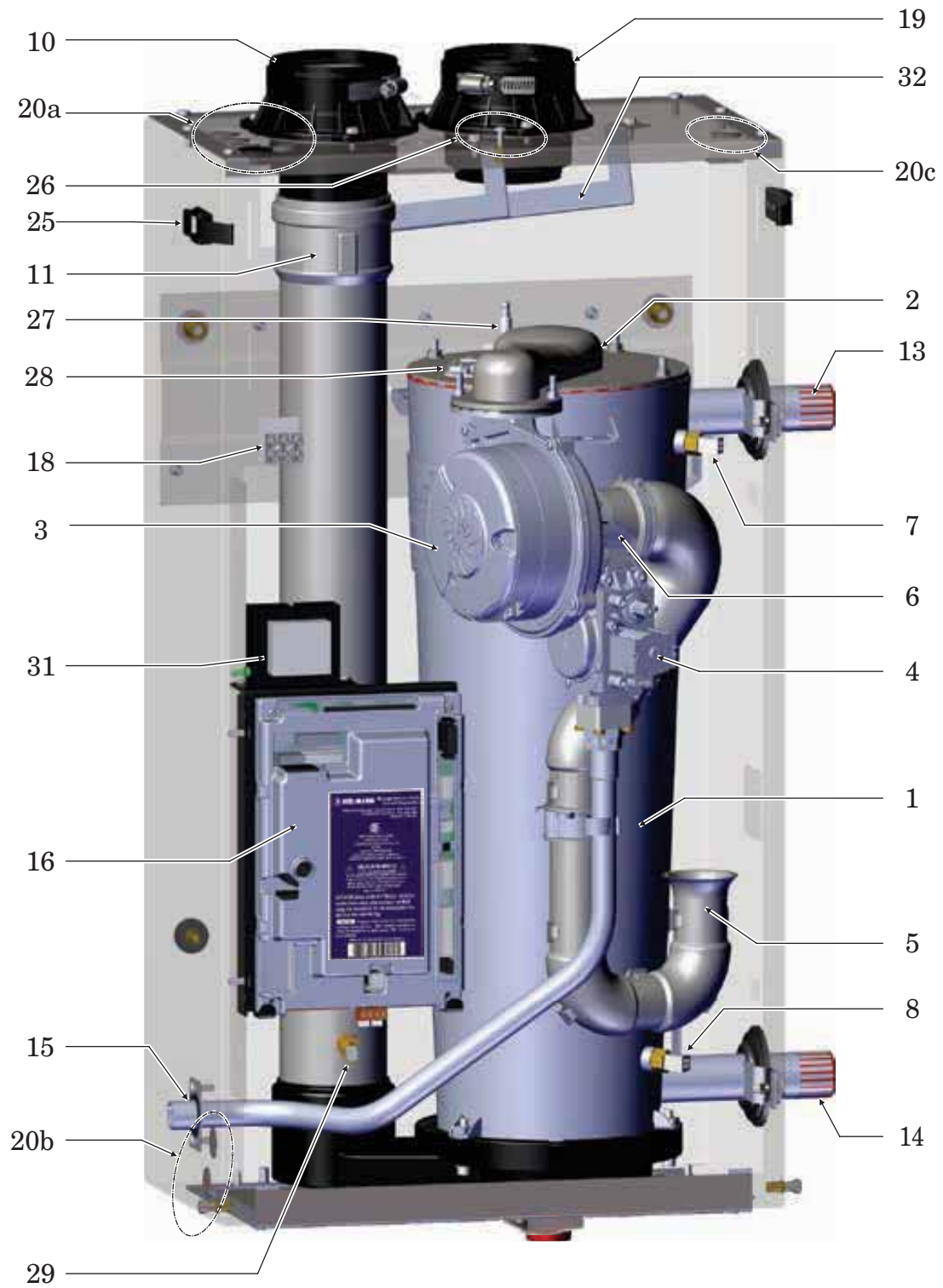

EVG-110
Interior
 (some components omitted for clarity)

EVG-003-110



The EVG-155 Gas-fired water boilers

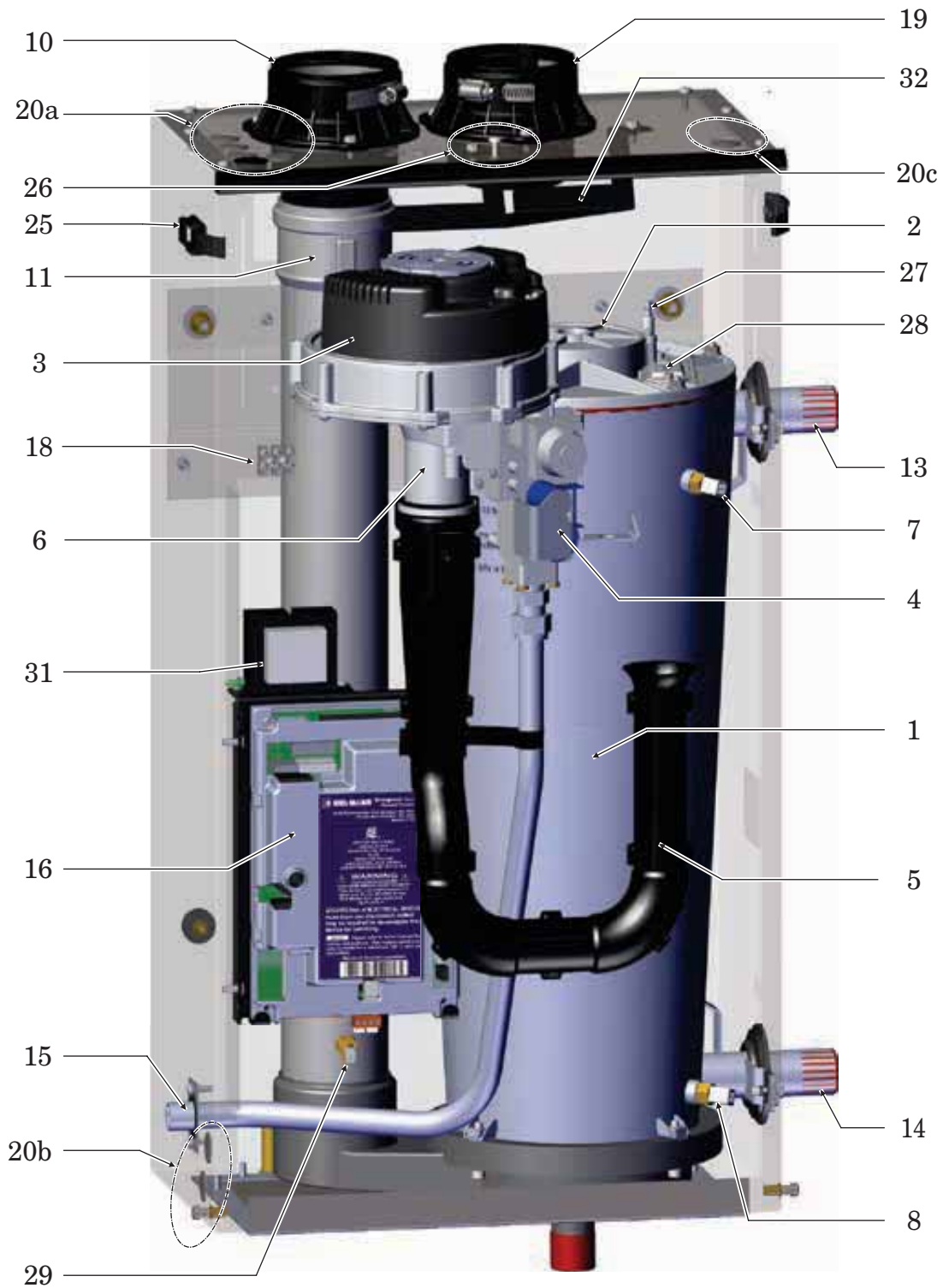

EVG-155
Interior
 (some components omitted for clarity)

EVG-003-155



Please read before proceeding

⚠ WARNING **Installer**— Read all instructions, including this manual and all other information shipped with the boiler, before installing. Perform steps in the order given.

User — This manual is for use only by a qualified heating installer/service technician. Refer to User's Information Manual for your reference.

User — Have this boiler serviced/inspected by a qualified service technician, at least annually. Failure to comply with the above could result in severe personal injury, death or substantial property damage.

NOTICE Write in the CP number in the space provided on the Installation certificate on page 141 if not already shown. When calling or writing about the boiler— Please have the boiler model number from the boiler rating label and the CP number from the boiler jacket. Consider piping and installation when determining boiler location.

Any claims for damage or shortage in shipment must be filed immediately against the transportation company by the consignee.

⚠ DANGER **If any part of a boiler, burner or its controls has been sprayed with or submerged under water, either partially or fully, DO NOT attempt to operate the boiler until the boiler has been either replaced or completely repaired, inspected, and you are sure that the boiler and all components are in good condition and fully reliable.**

Otherwise, by operating this boiler, you will cause a fire or explosion hazard, and an electrical shock hazard, leading to serious injury, death, or substantial property damage. See the instructions at right.

Saltwater Damage — The exposure of boiler components to saltwater can have both immediate and long-term effects. While the immediate effects of saltwater damage are similar to those of freshwater (shorting out of electrical components, washing out of critical lubricants, etc.), the salt and other contaminants left behind can lead to longer term issues after the water is gone due to the conductive and corrosive nature of the salt residue. Therefore, Weil-McLain equipment contaminated with saltwater or polluted water will no longer be covered under warranty and should be replaced.

Electrical Damage — If any **electrical component** or **wiring** came into contact with water, or was suspected to have come into contact with water, replace the boiler with a new Weil-McLain boiler.

⚠ WARNING Failure to adhere to the guidelines below can result in severe personal injury, death or substantial property damage.

EXPANSION TANK

- Relieve pressure from the system before isolating the expansion tank.

When servicing boiler —

- To avoid electric shock, disconnect all electrical supplies to the boiler before performing maintenance.
- To avoid severe burns, allow boiler to cool before performing maintenance.
- This boiler contains ceramic fiber and fiberglass materials. Refer to the WARNING and instructions on page 101.

Boiler operation —

- Do not block flow of combustion or ventilation air to boiler.
- Should overheating occur or gas supply fail to shut off, do not turn off or disconnect electrical supply to circulator. Instead, shut off the gas supply at a location external to the appliance.

Combustion air —

- DO NOT install combustion air intake where there is a risk of combustion air contamination.

Carbon monoxide detector —

- A carbon monoxide detector that is wired on the same electrical circuit as the boiler is strongly recommended.

SURGE PROTECTOR —

- Provide surge protection in the boiler power supply. This will reduce the possibility of damage to the boiler control.

Boiler water —

- The Evergreen® heat exchanger is made of stainless steel, and requires that system water chemistry be within the limits in this manual. **ADDITIONAL CHEMICAL TREATMENT MAY BE NECESSARY.** See page 91 for details.
- Thoroughly flush the system (**BEFORE** connecting boiler) to remove sediment. The high-efficiency heat exchanger can be damaged by build-up or corrosion due to sediment.
- Do not use petroleum-based cleaning or sealing compounds in boiler system. Gaskets and seals in the system may be damaged. This can result in substantial property damage.
- Continual fresh make-up water will reduce boiler life. Mineral buildup in heat exchanger reduces heat transfer, overheats the stainless steel heat exchanger, and causes failure. Addition of oxygen carried in by make-up water can cause internal corrosion. Leaks in boiler or piping must be repaired at once

to prevent make-up water. Use this boiler **ONLY** in a closed-loop system.

- Do not add cold water to a hot boiler. Thermal shock can cause the heat exchanger to crack.

Freeze protection fluids —

- NEVER use automotive or standard glycol antifreeze. Use only freeze-protection fluids made for hydronic systems. Follow all guidelines given by the antifreeze manufacturer. Thoroughly clean and flush any replacement boiler system that has used glycol before installing the new boiler. Use only the products listed by Weil-McLain for use with this boiler. See page 92 for details.

⚠ CAUTION **Frozen Water Damage Hazard**

Residences or buildings that are unattended in severely cold weather, boiler system components failures, power outages, or other electrical system failures could result in frozen plumbing and water damage in a matter of hours. For your protection, take preventative actions such as having a security system installed that operates during power outages, senses low temperature, and initiates an effective action. Consult with your boiler contractor or a home security agency.

Commonwealth of Massachusetts

- When the boiler is installed within the Commonwealth of Massachusetts:
- This product must be installed by a licensed plumber or gas fitter.
 - If antifreeze is used, a reduced pressure back-flow preventer device shall be used.
 - Sidewall vent air installations — see instruction on page 25.



Boiler location

Installations must comply with:

- Local, state, provincial, and national codes, laws, regulations and ordinances.
- National Fuel Gas Code, ANSI Z223.1/NFPA 54 – latest edition.
- National Electrical Code ANSI/NFPA 70 – latest edition. Electrical installation and grounding must be in accordance with CSA C22.1, Part 1, Canadian Electrical Code, and/or local codes.
- For Canada only: CAN/CSA B149.1, Natural Gas and Propane Installation Code, and any local codes.
- Where required by the authority having jurisdiction, the installation must conform to the Standard for Controls and Safety Devices for Automatically Fired Boilers, ANSI/ASME CSD-1.

NOTICE The Evergreen® boiler gas manifold and controls met safe lighting and other performance criteria when boiler underwent tests specified in ANSI Z21.13 – latest edition.

Before locating the boiler, check:

1. The Evergreen® boiler can be floor-standing or wall mounted.
2. Wall construction — If the boiler is wall-mounted, make sure the wall construction is suitable to carry the weight of the boiler and components. See page 10 for instructions.
3. The boiler is suitable for INDOOR installation only.
4. Check for nearby connection to:
 - System water piping
 - Venting connections
 - Gas supply piping
 - Electrical power
 - Condensate drain
5. Check area around boiler. Remove any combustible materials, gasoline and other flammable liquids.

WARNING Failure to keep boiler area clear and free of combustible materials, gasoline and other flammable liquids and vapors can result in severe personal injury, death or substantial property damage.

6. The Evergreen® boiler must be installed so that gas control system components are protected from dripping or spraying water or rain during operation or service.
7. If new boiler will replace existing boiler, check for and correct system problems, such as:
 - Sediment or corrosion in system piping — clean and flush piping BEFORE connecting the new boiler. See page 91.
 - System leaks causing oxygen corrosion or heat exchanger cracks from hard water deposits.
 - Incorrectly-sized expansion tank.
 - Lack of freeze protection in boiler water causing system and boiler to freeze and leak.

Residential garage installation

Precautions

1. Take the following special precautions when installing the boiler in a residential garage. If the boiler is located in a residential garage:
 - Mount the boiler with its burner and igniter are at least 18 inches above the floor. Follow the National Fuel Gas Code, ANSI Z223.1 for U. S. installations, or Natural Gas and Propane Installation Code, CSA B149.1 and B149.2 for Canadian installations.
 - Locate or protect the boiler so it cannot be damaged by a moving vehicle.
 - Ensure that the installation complies with all applicable codes.
 - Prevent boiler water and condensate from freezing.

Provide air openings to room

Evergreen® boiler alone in boiler room

1. No air ventilation openings into boiler room are needed if clearances around boiler are at least equal to the SERVICE clearances shown in Figure 1, page 9.
2. For spaces that DO NOT supply the minimum service clearances, provide two openings as shown in Figure 1, page 9. Each opening must provide 1 square inch free area per 1,000 Btuh of boiler input.



The space must be provided with combustion/ventilation air openings correctly sized for all appliances located in the same space as the Evergreen® boiler.

Reinstall boiler jacket door after servicing. The boiler jacket door must be securely fastened to the boiler to prevent boiler from drawing air from inside the boiler room. This is particularly important if the boiler is located in the same room as other appliances.

Failure to comply with the above warnings could result in severe personal injury, death or substantial property damage.

Evergreen® boiler in same space with other gas or oil-fired appliances

1. Follow the sizing requirements shown in Figure 25, page 27.

Vent and air piping

1. The EVG boiler requires a special vent system, designed for pressurized venting. The boilers are rated ANSI Z21.13 Category IV (pressurized vent, likely to condense in the vent). See instructions beginning on page 22.
2. You must also install air piping from outside to the boiler air intake adapter. The resultant installation is categorized as direct vent (sealed combustion). Note prevention of combustion air contamination on page 22 when considering vent/air termination.
3. Vent and air must terminate near one another unless otherwise specified in this manual. Vent and air piping may be routed vertically through the roof or out a side wall, following the options given in this manual. You may use any of the vent/air piping methods covered in this manual. Do not attempt to install the EVG boiler using any other means.
4. Be sure to locate the boiler such that the vent and air piping can be routed through the building and properly terminated. The vent/air piping lengths, routing and termination method must all comply with the methods and limits in instructions beginning on page 22.



Boiler location *(continued)*

Provide clearances for service access — RECOMMENDED

1. See Figure 1 for recommended service clearances.
2. If you do not provide minimum service clearances shown, it might not be possible to service the boiler without removing it from the space.
3. Clearance D, Figure 1 allows for the installation of piping as shown in Figure 8, page 12 plus a close nipple and elbow.

WARNING Closet or small-enclosure installations which do not provide at least these recommended clearances require the specially-sized and placed air openings shown in Figure 2.

Figure 1 RECOMMENDED service clearances (all dimensions are in inches)

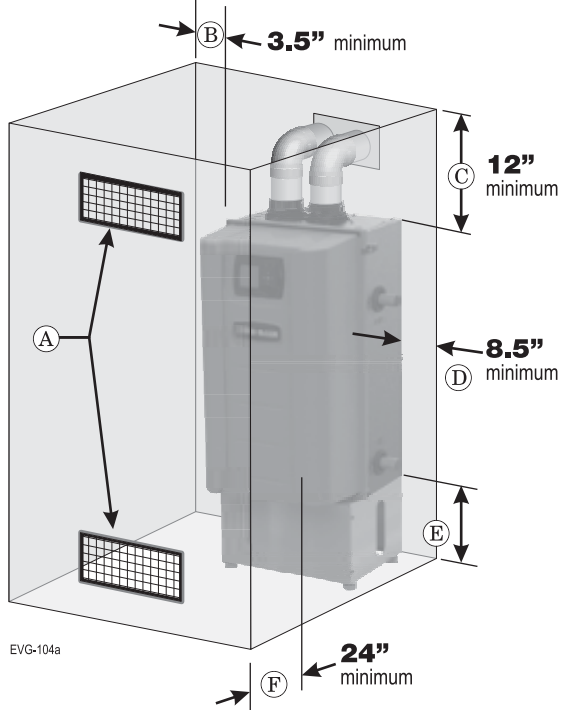

Provide clearances from combustible materials — REQUIRED

1. See Figure 2 for REQUIRED minimum clearances. ALL installation must provide at least these minimums.
2. Hot water pipes — at least 1/2 inches from combustible materials.
3. Vent pipe — at least 3/16 inches from combustible materials.
4. Clearance D, Figure 2 allows for the installation of a reducer bushing (155 only) and elbow. Other piping may require additional clearance.
5. See Figure 1 for service clearance minimums.

WARNING Closet or small-enclosure installations which do not provide at least the recommended service clearances shown in Figure 1 require the specially-sized and placed air openings shown in Figure 2.

Figure 2 REQUIRED minimum clearances (all dimensions are in inches)

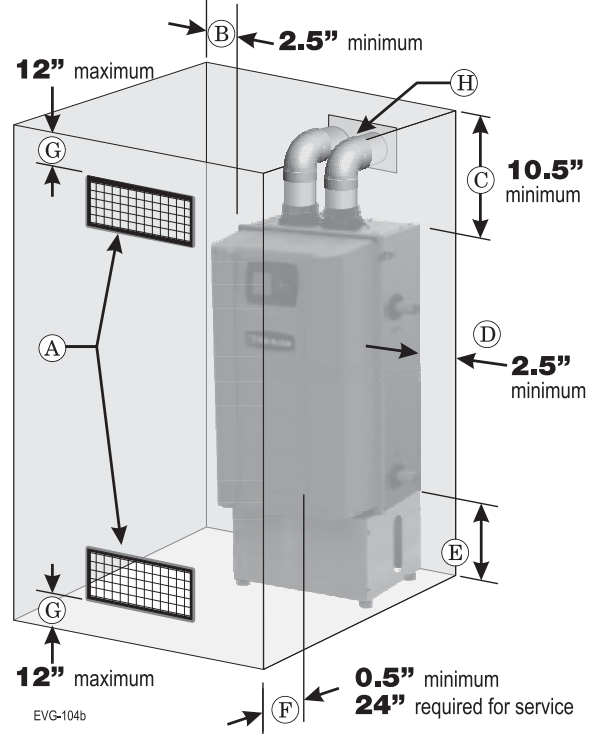

- A Provide combustion air/ventilation openings per Figure 25, page 27 or as otherwise directed in this manual or by applicable codes. NOTE: If the installation does not provide the minimum clearances in this illustration, then the enclosure must have air openings located and sized per Figure 2.
- B Left side service clearance = 3.5 inches minimum.
- C Service clearance above top of boiler = 12 inches minimum.
- D Right side service clearance = 8.5 inches minimum.
- E Service clearance below the boiler = 12 inches minimum for wall hung installation, 0 inches minimum for floor standing installation.
- F Service clearance in front of the boiler = 24 inches minimum.

NOTICE ADDITIONAL service clearance may be needed, depending on how piping is routed to the boiler.

- A Provide combustion air/ventilation openings per Figure 25, page 27 or as otherwise directed in this manual or by applicable codes. **NOTICE** If the installation does not provide the minimum clearances in Figure 1, then the enclosure **MUST HAVE** air openings located per Figure 2, above. Each of these air openings must have free area of at least 1 square inch per 1,000 MBH of boiler input.
- B Left side clearance to combustibles = 2.5 inches minimum.
- C Top of boiler clearance to combustibles = 10.5 inches minimum.
- D Right side clearance to combustibles = 2.5 inches minimum.
- E Bottom of boiler clearance to combustibles = 7 inches minimum (must be 18 inches above floor for garage installations) for wall hung installation, 0 inches minimum for floor standing installation.
- F Clearance in front of the boiler = 0.5 inches, but 24 inches minimum required for service.
- G Air openings must be located in the FRONT of the enclosure, as shown. They must be no more than 12 inches from the floor or ceiling, as shown.
- H Vent pipe must be minimum 3/16 inch from combustibles. Opening in combustible wall, floor, ceiling or roof must be 3/8 inches larger than flue pipe diameter, fitted with corrosion resistant steel thimble, or larger if required by codes or as specified by vent pipe manufacturer.



Prepare boiler location

Flooring and foundation

Flooring

1. The boiler is approved for installation on combustible flooring, but must never be installed on carpeting.

▲WARNING Do not install boiler on carpeting even if foundation is used. Fire can result, causing severe personal injury, death or substantial property damage.

Foundation

1. Provide a solid foundation pad, at least 2 inches above the floor, if any of the following is true:
 - floor can become flooded.
 - the floor is dirt, sand, gravel or other loose material.
 - the boiler mounting area is severely uneven or sloped.
2. The minimum foundation size is:
 - Evergreen®: 18 inches wide x 18 inches deep
3. Foundation may be of wood, brick or concrete (minimum 2 inches thick) construction.

If flooding is possible, elevate boiler sufficiently to prevent water from reaching boiler.

Remove boiler from crate

▲WARNING The boiler is heavy. Use caution not to drop the boiler or cause bodily injury while lifting and handling. Verify that the boiler is securely attached to prevent possibility of boiler falling after installation.

▲WARNING After the boiler is removed from the shipping carton, **DO NOT** allow the boiler to sit on its bottom. This would cause pressure on protruding plastic, resulting in interior damage. Either lay the boiler on its back or leave on the styrofoam protective shipping base.

Do not drop boiler or bump jacket on floor or pallet. Damage to boiler can result.

▲CAUTION Cold weather handling — If boiler has been stored in a very cold location (below 0°F) before installation, handle with care until the plastic components come to room temperature.

1. The Evergreen® boiler is generally easier to handle and maneuver after removing the shipping container.
2. Remove items 1, 2, 3 and 6 in Figure 3. Remove trim kit and parts from item 2.
3. **Leave the boiler resting on the styrofoam protective base** (item 6) and bottom cardboard cap (item 7), until ready to place on the wall. If removing the boiler from the shipping base, rest the boiler on its back, NOT on its bottom.

Wall-mounting the boiler

Wall-mounting requirements

▲WARNING DO NOT attempt to attach the wall mount bracket using anchors or any means other than directly securing to the wall studs (or equivalent wood structure if studs are not on 16-inch centers).

The wall must be vertically plumbed and capable of carrying the weight of the boiler and any attached piping components.

Wall-mounting the boiler

(continued)

The operating weights for Evergreen® boilers are:

	Without Stand lbs.	With Stand lbs.
EVG 70	112	125
EVG 110	107	120
EVG 155	129	143

▲WARNING Failure to comply with above and the procedure given below could result in severe personal injury, death or substantial property damage.

1. Stud spacing: Bracket holes are spaced for studs on 16-inch centers. For other stud spacing, provide secure, solid mounting surface on which to attach the boiler wall-mounting bracket. The mounting surface must not extend above the top of the boiler jacket.
2. Wood stud wall: Install bracket with lag screws (3/8" x 3") included in kit, only into the studs.
3. Metal stud wall: Secure bracket and spacer board to studs with 3/16-inch toggle bolts and 3/16-inch flat washers (not included with kit).

Figure 3 Boiler shipping container

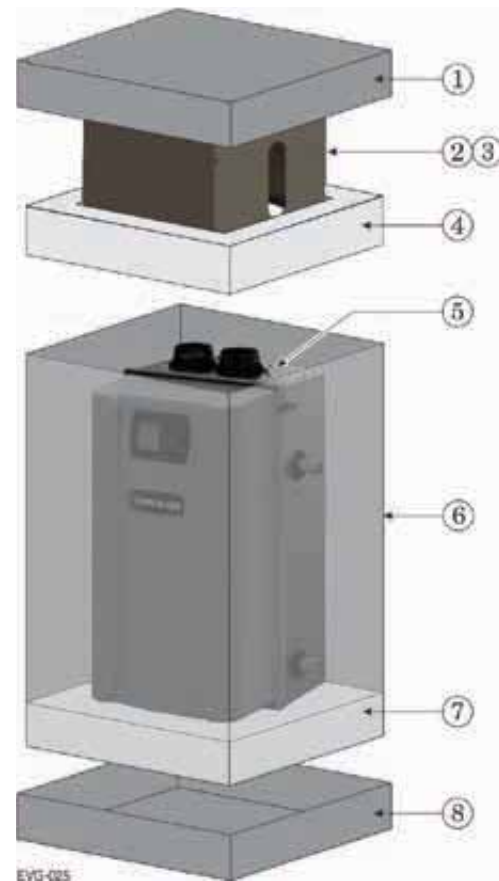

1 Cardboard cap, top	5 Boiler
2 Floor stand assembly	6 Cardboard sleeve
3 Trim box (nestled inside Floor stand assembly)	7 Styrofoam protective base
4 Styrofoam protective cap	8 Cardboard cap, bottom



Wall-mounting the boiler (continued)

⚠WARNING Verify that the studs are suitable for carrying a wall-mounted load. Some metal studs are not designed for this purpose.

- If the mounting wall has exposed studs, installer must provide a backer board to mount boiler. Boiler cannot be leveled without a backing surface.
- Mount the boiler on the wall following these instructions. The boiler mounting studs must engage with the wall-mount bracket. Make sure the bracket is not just resting on the edge of the mounting stud or washer. Perform all procedures given in the Boiler Manual on previous pages before mounting the boiler.

Install the wall-mount bracket (by installer)

- See Figure 4.
- Locate the studs — must be on 16-inch centers. See previous page instructions if studs are not on 16-inch centers.
- Place the wall-mount bracket (Figure 4, item 2) on the wall, using a level to align correctly.
- Place the wall-mount bracket so the mounting slots are centered over the studs.
- Level the bracket and trace the outline of the screw slots with a pencil.
- Remove the mounting bracket and drill holes 1/4" diameter by 3 inches deep, centered on the screw slot outlines. (For metal stud walls, using 3/16" toggle bolts, drill required clearance holes.)
- Position the wall-mount bracket on the wall. Insert and loosely tighten the two lag screws (or toggle bolts for metal studs).
- Level the wall-mounting bracket. Then tighten lag screws securely. For drywall or plaster lathe installations, avoid tightening so much that the bracket digs into the wall surface.

Place boiler on bracket

- See Figure 5. The wall-mount bracket must be installed before mounting the boiler.
- Measure 22 1/2 inches below the bottom edge of the wall-mount bracket (item 2). Strike a line or place a piece of masking tape with its top edge even with the 22 1/2-inch mark. (This line, or tape, will indicate whether the boiler has been properly seated onto the wall-mount bracket.)

Figure 4 Wall-mount bracket and studs

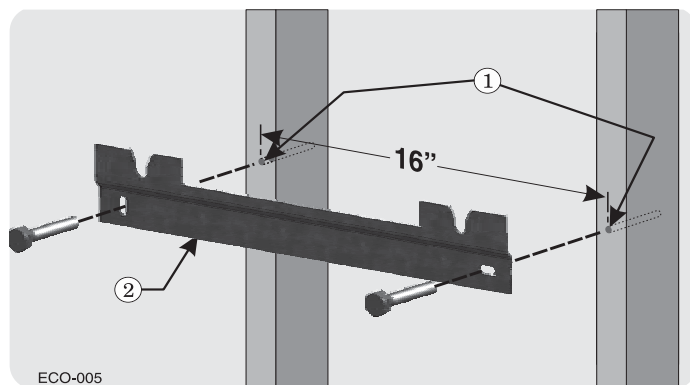

- 1 Studs** — Pre-drill through the wall into the studs 1/4 inch diameter x 3 inches deep for 3/8-inch lag screws— Studs must be on 16-inch centers. If studs are any other spacing, provide a secure, solid mounting surface on which to attach the boiler wall-mounting bracket.
- 2 Wall-mount bracket**

⚠WARNING The boiler is heavy, and requires two people to lift and place. Wear non-slip leather gloves to prevent possibility of cuts from sheet metal edges.

The jacket door can be left in place when handling the boiler, but the boiler must ONLY be lifted by the bottom and rear of the sheet metal housing — NOT by any pipe or plastic part.

- Obtain assistance to lift the boiler into position.**
- Lift the boiler high enough that its mounting studs (Figure 6, page 12, item 3) will be above the wall-mount bracket (item 2).
- Let the rear of the boiler slide against the lag screw heads as you lower the boiler into place. The V-groove will help guide the studs into the slot.

Figure 5 Place boiler on wall-mount bracket

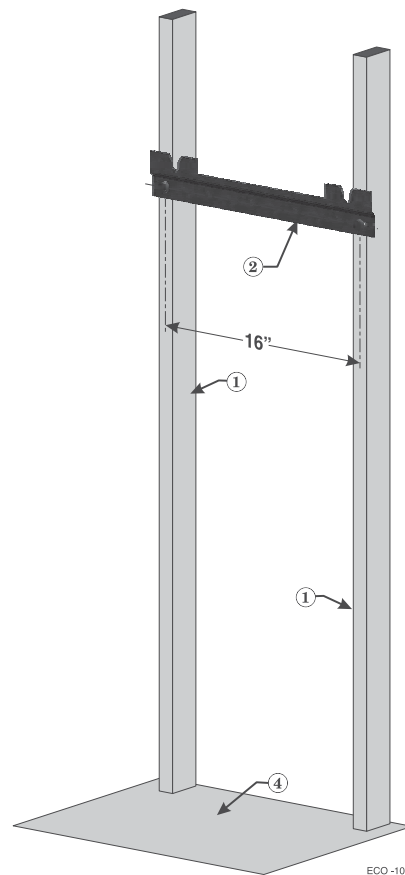

- 1 Studs** — Pre-drill through the wall into the studs 1/4 inch diameter x 3 inches deep — Studs must be on 16-inch centers. If studs are any other spacing, provide a secure, solid mounting surface on which to attach the boiler wall-mounting bracket.
- 2 Wall-mount bracket** — secure wall mount bracket to wall as instructed on previous page.
- 3 Boiler mounting studs** (Figure 6 back of boiler) — The V-groove on the wall-mount bracket will help guide the studs into the slots. The studs are attached to the back of the boiler.
- 4 Floor surface**



Wall-mounting the boiler

(continued)

Figure 6 Boiler mounting studs

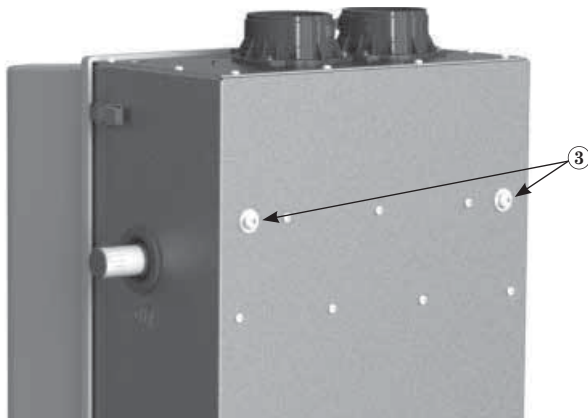

6. When the brackets are engaged correctly, the bottom of the boiler enclosure will be at or near the pencil line, or tape, you applied in step 2.
7. Adjust the studs properly until engaged with the bracket and the boiler slips into the correct position.

▲WARNING When mounting the boiler, use the method described on step 2, page 11 to ensure the mounting studs are properly engaged. If not, the boiler could fall. Failure to comply could result in severe personal injury, death or substantial property damage.

8. Ensure boiler is level front-to-back.

▲WARNING Ensure boiler is NOT pitched upward with the front of the boiler higher than the back of the boiler. This can prevent condensate from draining properly. Failure to comply could result in severe personal injury, death or substantial property damage.

Floor Stand Assembly

Floor Standing

▲WARNING The boiler is heavy, and requires two people to lift and place upright. Use caution not to drop the boiler or cause bodily injury while lifting and handling. Wear non-slip gloves to prevent possibility of cuts from sheet metal edges. After the boiler is removed from the shipping carton, DO NOT allow the boiler to sit on its bottom, before stand is installed. Doing so may result in damage to the condensate dish.

1. Carefully remove boiler from styrofoam protective base and set on back. Remove door from front of boiler by loosening screw on top of boiler and unfastening latches on side of cabinet.
2. Remove four (4) 5/16" studs from floor stand hardware trim bag. Install studs by hand in rivet nuts on bottom of Evergreen® boiler. See Figure 7.
3. Remove front access panel from stand assembly using 5/16" driver.
4. Align holes in top of stand with studs on bottom of boiler. Slide stand over studs. Remove 5/16" nuts from trim bag. Install nuts on studs using 1/2" socket or wrench. Make sure to align sides of stand with cabinet before tightening down nuts. Do not overtighten.
5. Install the condensate trap assembly following instructions on page 53
6. After confirming nuts are tightened, obtain assistance and lift the boiler into upright position.
7. Set boiler in place and level by adjusting leveling legs with flat head screwdriver.

Figure 7 Floor stand assembly (front access panel removed)



EVG-008



Boiler hydrostatic test

⚠WARNING DO NOT install a relief valve with a pressure higher than 30 PSIG. This is the maximum allowable relief valve setting for the boiler. Failure to comply could prevent the relief valve from operating as needed, resulting in possibility of severe personal injury, death or substantial property damage.

⚠WARNING Use two wrenches when tightening any pipe connection to the boiler. Failure to prevent the boiler pipes from turning could damage pipes or heat exchanger, resulting in possible severe personal injury, death or substantial property damage.

Hydrostatic pressure test

Pressure test the boiler before permanently attaching water or gas piping or electrical supply.

Install pipe fittings for relief valve and P/T gauge

1. Install the reducer bushings (155 only), reducing tees, and close nipples, shipped loose with the boiler, located and oriented as shown in Figure 8, page 14.

NOTICE Boilers installed in locations with less than the RECOMMENDED service clearances will need to adjust piping layout to meet space requirements.

2. Apply pipe dope to all fittings sparingly.

⚠WARNING DO NOT install the relief valve until after the hydrostatic test. Temporarily install a 3/4" pipe plug in the relief valve location as directed in these instructions. The plug must be removed after the test.

⚠WARNING Connect the relief valve ONLY on the BOILER SUPPLY OUTLET, NOT the boiler return. Connect the relief valve only as shown in this manual. Ensure relief valve is located above heat exchanger.

Failure to comply with the above could prevent the relief valve from operating as needed, resulting in possibility of severe personal injury, death or substantial property damage.

3. Install the pressure/temperature gauge to the reducing tee as shown in Figure 8, page 14.

Install fittings and valves required for hydrostatic testing

1. The following piping components (supplied by installer) are required for the test configuration:
 - a. Two shut-off valves (1" NPT on 70/110, 1 1/4" NPT on 155).
 - b. Two close nipples (1" NPT on 70/110, 1 1/4" NPT on 155).
 - c. 3/4" NPT pipe plug.

2. TEMPORARILY insert a 3/4" NPT pipe plug in the relief valve tapping. After the hydrostatic test, this plug must be removed and the relief valve must be installed.

Fill and pressure test

1. See Figure 9, page 14 for use with the following instructions.
2. CLOSE the boiler drain valve (item 11). Connect a hose to fresh water supply and to the drain valve.
3. Place a bucket under the ends of the isolation valves (item 9 and 10) to catch water drippings.
4. CLOSE isolation valve item 10, then crack open the valve slightly. Leave isolation valve item 9 open.
5. Slowly open the boiler drain valve (item 11) and fresh water supply to fill boiler with water. The boiler and piping will fill quickly because of the low water content.
6. When water begins to flow from bottom isolation valve (item 10), close the valve.
7. Continue filling until water flows from top isolation valve (item 9), then close the valve.
8. When pressure on the pressure/temperature gauge (item 4) reaches at least 45 PSIG, but no higher than 55 PSIG, CLOSE the boiler drain valve (item 11).
9. Hold at test pressure for 10 minutes.

⚠WARNING Do not leave boiler unattended. A cold water fill could expand and cause excessive pressure, resulting in severe personal injury, death or substantial property damage.

10. Make sure constant gauge pressure has been maintained throughout test. Check for leaks. Repair if found.

⚠WARNING Leaks must be repaired at once. Failure to do so can damage boiler, resulting in substantial property damage.

⚠WARNING Do not use petroleum-based cleaning or sealing compounds in boiler system. Gaskets and seals in the system may be damaged. This can result in substantial property damage.

Drain and remove fittings

1. Disconnect fill water hose from water source.
2. Drain boiler through drain valve (item 11).

⚠WARNING Use caution when releasing pressure from the boiler. Rapid water flow could cause injury.

3. Remove hose after draining.
4. Remove nipples and valves unless they will remain for use in the system piping.
5. Remove plug and install relief valve as specified in the following WARNING.

⚠WARNING Remove plug from relief valve tee. Install the relief valve in the 3/4" tee. See page 45 or page 49 to install relief valve discharge piping. Failure to install the boiler relief valve could result in severe personal injury, death or substantial property damage.

Boiler hydrostatic test *(continued)*

Figure 8 Install pipe fittings for relief valve and pressure/temperature gauge — **DO NOT mount relief valve until AFTER hydrostatic testing** (see legend below)



Figure 9 Install piping components required for hydrostatic test (see legend below)

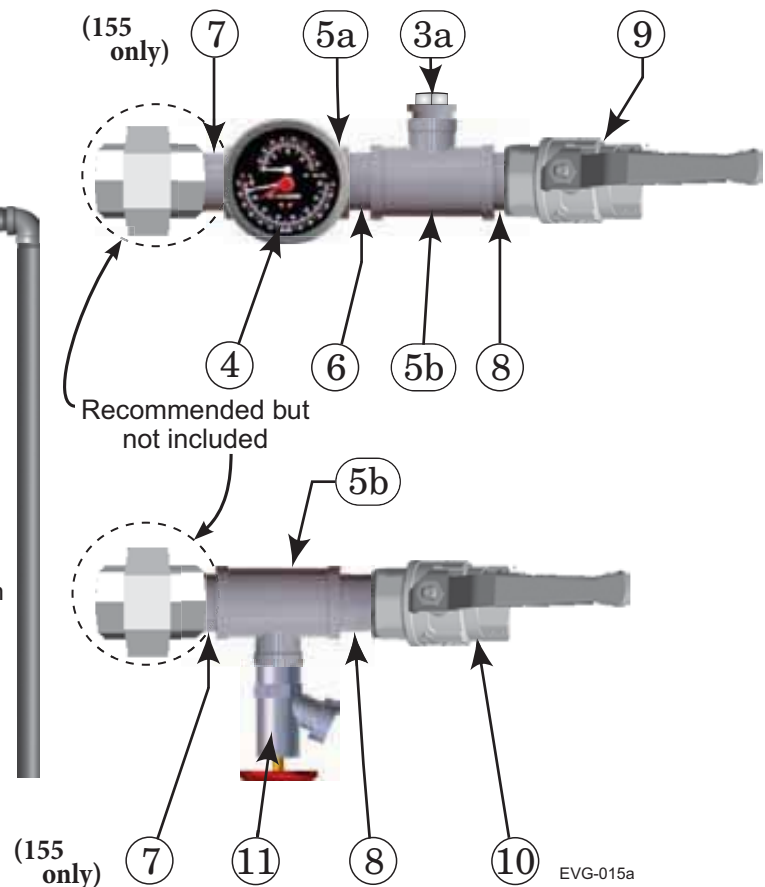

- 1 Boiler supply (outlet) connection, (male, 1" NPT)
- 2 Boiler return (inlet) connection, (male, 1" NPT)
- 3 Boiler relief valve, shipped loose with boiler — **DO NOT mount relief valve until AFTER hydrostatic testing.**
- 3a **TEMPORARILY ONLY** — Insert a 3/4" NPT plug in the relief valve tapping of the reducing tee. **This MUST BE REMOVED after the test and the relief valve mounted here.**
- 4 Pressure/temperature gauge, shipped loose with boiler
- 5a Reducing tee, NPT, 1" x 1" x 1/4" on 70/110, & 1 1/4" x 1 1/4" x 1/4" on 155, shipped loose with boiler
- 5b Reducing tee, NPT, 1" x 1" x 3/4" on 70/110, & 1 1/4" x 1 1/4" x 3/4" on 155, shipped loose with boiler
- 6 Nipple, NPT 1" x close on 70/110, & 1 1/4" x close on 155, shipped loose with boiler
- 7 Bushing, NPT, 1 1/4" x 1", shipped loose with boiler (155 only)
- 8 Nipple, NPT 1" x close on 70/110, & 1 1/4" x close on 155, by installer
- 9 Isolation valve on supply connection, by installer (1" NPT on 70/110, 1 1/4" NPT on 155)
- 10 Isolation valve on return connection, by installer (1" NPT on 70/110, 1 1/4" NPT on 155)
- 11 3/4" NPT boiler drain valve, shipped loose with boiler — after hydrostatic testing, move drain valve to lowest point on the return piping if not already there.



Converting boiler to propane — EVG 70

Prepare boiler for propane — EVG 70 only (if required)

Propane operation

⚠️WARNING ALL Evergreen® boilers must be converted for propane operation.

Converting an existing natural gas-fired boiler for propane — For a boiler already installed, you must turn off gas supply, turn off power and allow boiler to cool before proceeding. You must also completely test the boiler after conversion to verify performance and start up the boiler following instructions beginning on page 91 of this manual.

Verify 70 propane gas orifice size — See Figure 10. Verify when installing that the orifice size marking is correct. Orifices will be stamped as in illustration or with “3.75” for model 70.

Failure to comply could result in severe personal injury, death or substantial property damage.

Installing propane orifice — EVG 70 only

⚠️WARNING If boiler is already installed — You must turn off electrical supply to the boiler and close the external manual gas shut-off valve to isolate the boiler during conversion. Allow the boiler to cool if it has been operating.

Following conversion of an installed boiler, follow all instructions in this manual to start up the boiler and verify operation of the boiler and all system components.

1. Locate the propane orifice from the propane conversion kit bag.
2. Verify that the stamping on the orifice is correct for the model size (see Figure 10).
3. If the jacket door is not already removed, remove it.
4. Locate the gas valve and venturi (see Figure 11).
5. Pull the gas valve retention ring (item 3, Figure 11) off of the gas valve/venturi joint.
6. Carefully pull the gas valve to the right until it is free of the venturi. Leave the pressure reference hose (item 4, Figure 11) connected at both ends.

Figure 10 Propane gas orifice identification EVG 70 (may be stamped 3.75)



Figure 11 Gas valve and venturi

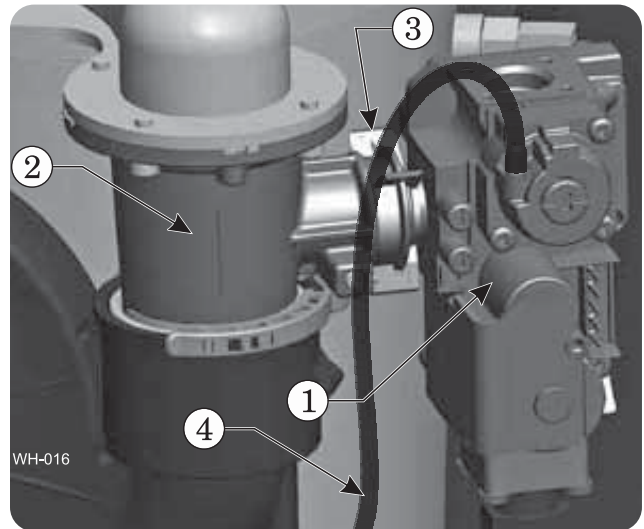

- | | |
|---|--|
| 1 | Gas valve |
| 2 | Venturi |
| 3 | Gas valve retention ring |
| 4 | Pressure reference hose — LEAVE CONNECTED AT BOTH ENDS |

⚠️WARNING Support the gas valve after disconnecting it. DO NOT allow it to hang from the gas valve flex line. When re-attaching the gas valve, ensure the gas valve-to-venturi O-ring (item 5, Figure 12, page 16) is in place and in good condition. Inspect the gas valve flex line to ensure it is undamaged and in good condition.

Converting boiler to propane — EVG 70 *(continued)*

Figure 12 Installing the propane gas orifice (some details omitted for clarity)

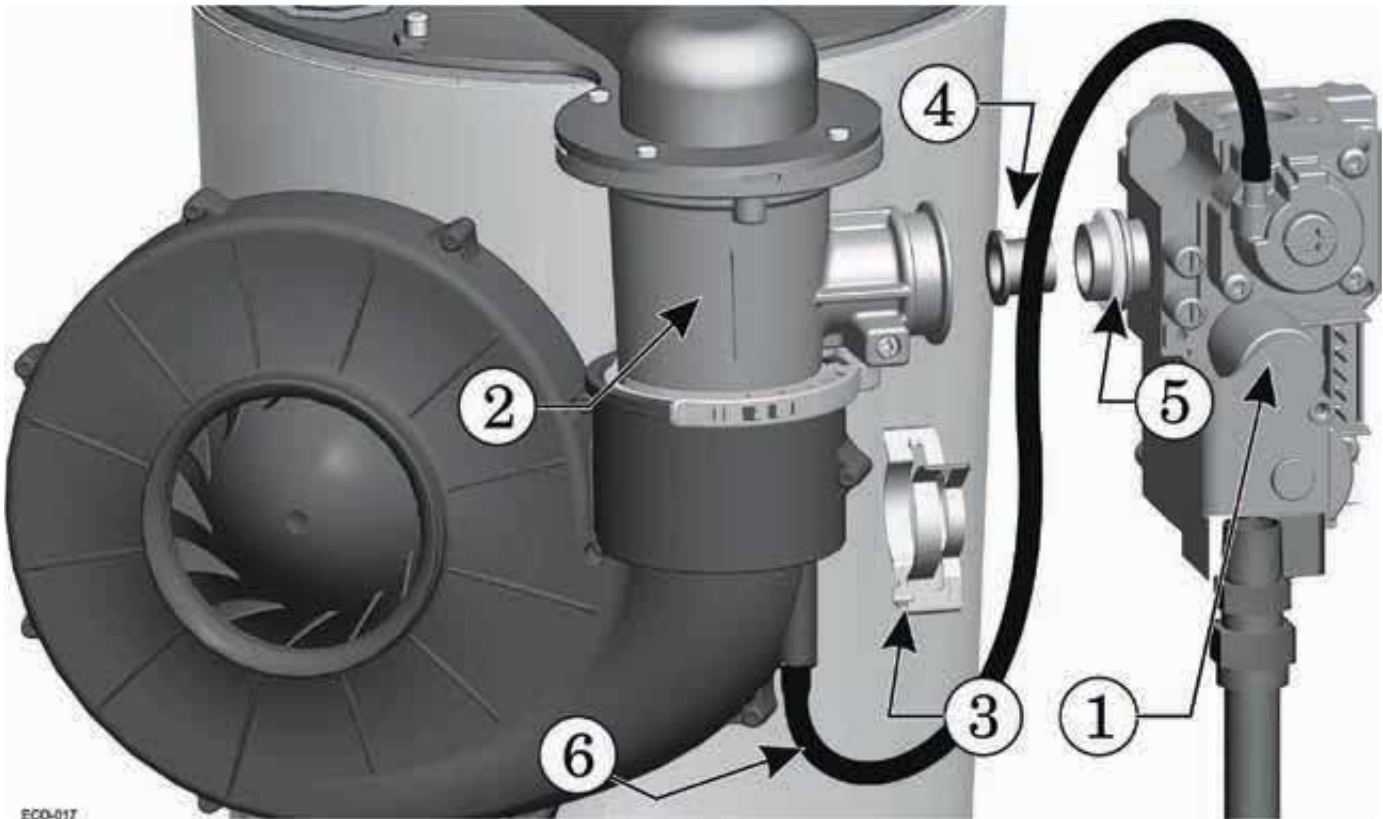

7. See Figure 12. Insert the propane gas orifice (item 4) into the gas valve outlet as shown.
8. Press the orifice into the gas valve outlet until the bushing flange butts against the gas valve outlet.

⚠ DANGER Inspect the O-rings on the propane gas orifice and on the gas valve outlet (item 5, Figure 12). The O-rings must be in good condition and must be installed. Failure to comply will cause a gas leak, resulting in severe personal injury or death.

9. Reposition gas valve into the venturi and reinstall the gas valve retention ring (item 3, Figure 12).

⚠ WARNING **DO NOT ATTEMPT TO MEASURE VALVE OUTLET PRESSURE.** The valve could be damaged by manometer fluid contamination. Failure to comply could result in severe personal injury, death or substantial property damage.

10. After installation is complete, attach the propane conversion label (in conversion kit bag) next to the boiler rating plate.
11. Perform complete start-up sequence (beginning on page 91), including check for gas leaks and checking for proper operation.
12. Reinstall jacket door.

LEGEND for Figure 12

- 1 Gas valve
- 2 Venturi
- 3 Gas valve retention ring
- 4 Propane orifice with o-ring
- 5 Gas valve o-ring
- 6 Pressure reference hose — LEAVE CONNECTED AT BOTH ENDS

⚠ WARNING **The jacket door must be in place during operation.** DO NOT operate the boiler with the jacket door removed except for inspection and testing as directed in this manual.



Converting boiler to propane — EVG 110

Prepare boiler for propane — EVG 110 only (if required)

Propane operation

⚠WARNING ALL Evergreen® boilers must be converted for propane operation.

Converting an existing natural gas-fired boiler for propane — For a boiler already installed, you must turn off gas supply, turn off power and allow boiler to cool before proceeding. You must also completely test the boiler after conversion to verify performance and start up the boiler following instructions beginning on page 91 of this manual.

Verify 110 propane gas orifice size — See Figure 13. Verify when installing that the orifice size marking is correct. Orifices will be stamped as in illustration or “3.7” for model 110.

Failure to comply could result in severe personal injury, death or substantial property damage.

Installing propane orifice — EVG 110 only

⚠WARNING **If the boiler is already installed** — You must turn off electrical supply to the boiler and close the external manual gas shut-off valve to isolate the boiler during conversion. Allow the boiler to cool if it has been operating.

Following conversion of an installed boiler, follow all instructions in this manual to start up the boiler and verify operation of the boiler and all system components.

1. Locate the propane orifice from the propane conversion kit bag.
2. Verify that the stamping on the orifice is correct for the model size (see Figure 13).
3. If the jacket door is not already removed, remove it.
4. Locate the gas valve and venturi (see Figure 14).
5. Release the gas line from the silencer bracket clip (item 5, page 18) and rotate it out of the way.
6. Use a T25-mm torx bit to remove the two (2) bolts (item 3) that secure the gas valve to the venturi.

Figure 13 Propane gas orifice identification EVG 110 (may be stamped 3.7 only)



EVG-160

Figure 14 EVG 110 Gas valve and venturi

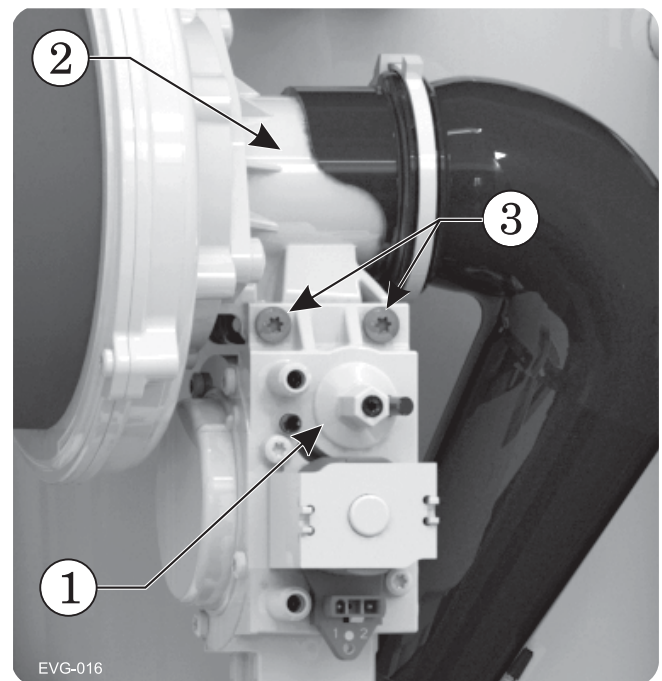

EVG-016

- 1 Gas valve
- 2 Venturi
- 3 Gas valve screws to venturi

⚠WARNING **Support the gas valve after disconnecting it. DO NOT allow it to hang from the gas valve flex line.** When re-attaching the gas valve, ensure the gas valve propane orifice is properly seated in rubber boot (item 6, Figure 15, page 18) and is in place and in good condition. Inspect the gas valve flex line to ensure it is undamaged and in good condition.



Converting boiler to propane — EVG 110 *(continued)*

Figure 15 EVG-110 -Installing the propane gas orifice (some details omitted for clarity)

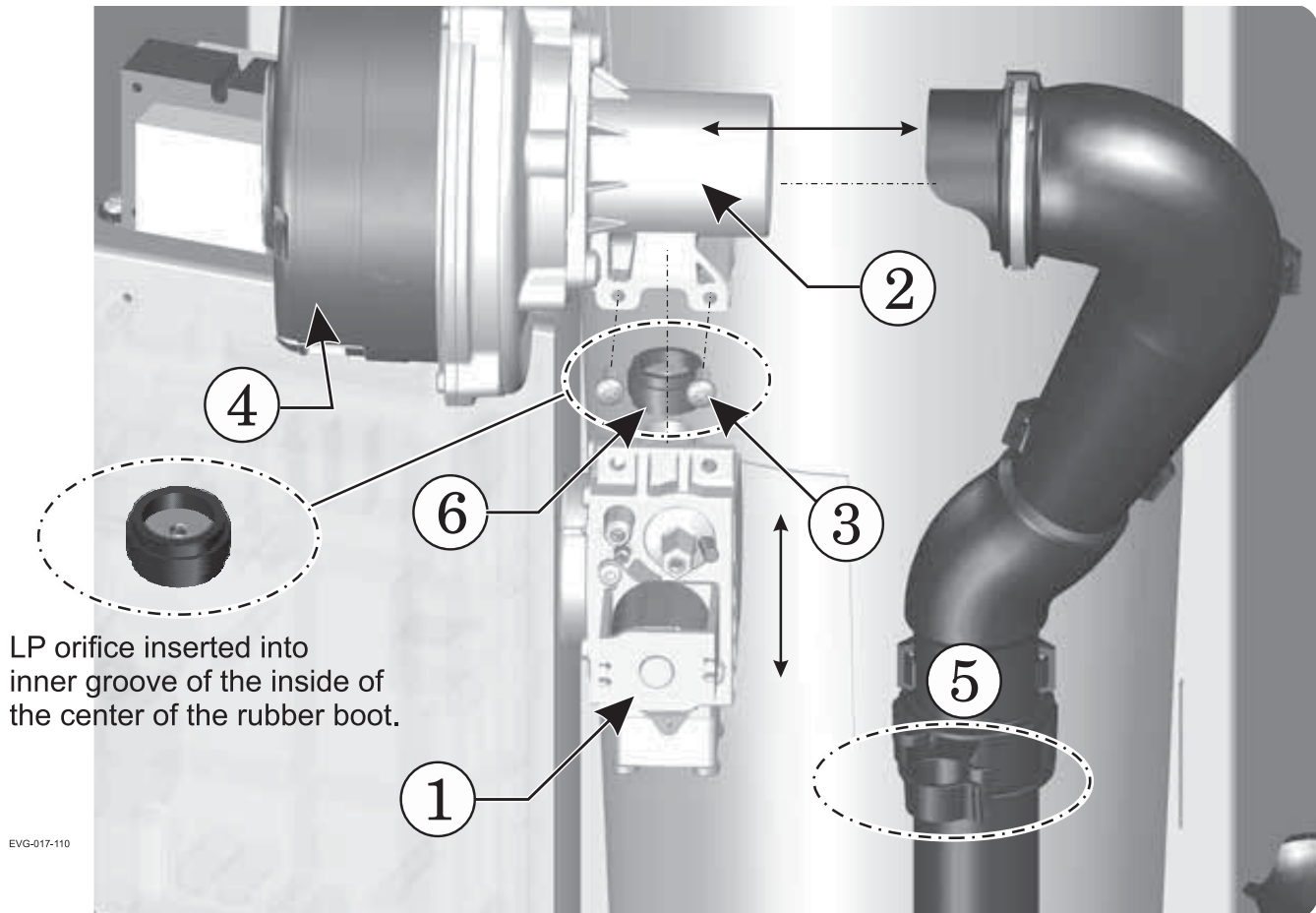

7. See Figure 15, Carefully pull the gas valve down until it is free of the venturi. Securely support the gas valve — DO NOT leave it dangling.
8. Remove the rubber boot from the gas valve or venturi.
9. Insert the propane gas orifice into the rubber boot. Orifice must be seated into the inner groove inside the center of the rubber boot.
10. Install the rubber boot (item 6) guaranteeing that it is firmly seated on the gas valve opening.

⚠ DANGER When re-attaching the gas valve, ensure the gas valve rubber boot (item 6, Figure 15) is in place and in good condition. Failure to comply will cause a gas leak, resulting in severe personal injury or death.

11. Reposition gas valve onto the venturi and reinstall the gas valve retention bolts (item 3). Make sure the rubber boot is fully seated on both the gas valve and venturi.
12. Swing the silencer bracket clip (item 5) back into position and snap on to the gas line.

⚠ WARNING **DO NOT ATTEMPT TO MEASURE VALVE OUTLET PRESSURE.** The valve could be damaged by manometer fluid contamination. Failure to comply could result in severe personal injury, death or substantial property damage.

LEGEND for Figure 15

- 1 Gas valve
- 2 Venturi
- 3 Bolts (2) for attaching gas valve to venturi
- 4 Blower
- 5 Air silencer bracket clip
- 6 Propane orifice with boot

13. After installation is complete, attach the propane conversion label (in conversion kit bag) next to the boiler rating plate.
14. Perform complete start-up sequence (beginning on page 91), including check for gas leaks and checking for proper operation.
15. Reinstall jacket door.

⚠ WARNING **The jacket door must be in place during operation.** DO NOT operate the boiler with the jacket door removed except for inspection and testing as directed in this manual.



Converting boiler to propane — EVG 155

Prepare boiler for propane — EVG 155 only (if required) Propane operation

▲WARNING ALL Evergreen® boilers must be converted for propane operation.

Converting an existing natural gas-fired boiler for propane — For a boiler already installed, you must turn off gas supply, turn off power and allow boiler to cool before proceeding. You must also completely test the boiler after conversion to verify performance and start up the boiler following instructions beginning on page 91 of this manual.

Verify propane gas orifice size — See Figure 16. Verify when installing that the orifice size marking is correct. Orifice will be stamped as in illustration.

Failure to comply could result in severe personal injury, death or substantial property damage.

Installing propane orifice — EVG 155 only

▲WARNING **If boiler is already installed** — You must turn off electrical supply to the boiler and close the external manual gas shut-off valve to isolate the boiler during conversion. Allow the boiler to cool if it has been operating.

Following conversion of an installed boiler, follow all instructions in this manual to start up the boiler and verify operation of the boiler and all system components.

1. Locate the propane orifice from the propane conversion kit bag.
2. Verify that the stamping on the orifice is correct for the model size (see Figure 16).
3. If the jacket door is not already removed, remove it.
4. See Figure 17, page 20 and Figure 18, page 20 for the following.
5. Locate the gas valve and venturi (items 1 and 3).
6. Release the gas line to silencer bracket (item 6) from the gas line and rotate it forward out of the way.
7. Use a 5mm hex wrench to remove the three (3) Allen screws (item 2) that secure the gas valve to the venturi.
8. See Figure 18, page 20. Carefully pull the gas valve to the right until it is free of the venturi. Securely support the gas valve — DO NOT leave it dangling.

Figure 16 Propane gas orifice identification
EVG 155



▲WARNING **Support the gas valve after disconnecting from the venturi. DO NOT allow it to hang from the gas valve flex line.** When re-attaching the gas valve, ensure the gas valve grommet (item 8, Figure 18, page 20) is in place and in good condition. Inspect the gas valve flex line to ensure it is undamaged and in good condition.

9. Insert the propane gas orifice (item 7) into the gas valve opening as shown in Figure 18, page 20.
10. Make sure that the rubber grommet (item 8) is firmly seated in the gas valve opening.

▲DANGER When re-attaching the gas valve, ensure the gas valve grommet (item 8, Figure 18, page 20) is in place and in good condition. Failure to comply will cause a gas leak, resulting in severe personal injury or death.

11. Reposition gas valve onto the venturi and reinstall the gas valve retention screws (item 2).
12. Swing the gas line to silencer bracket (item 6) back into position and snap onto the gas line.

▲WARNING **DO NOT ATTEMPT TO MEASURE VALVE OUTLET PRESSURE.** The valve could be damaged by manometer fluid contamination. Failure to comply could result in severe personal injury, death or substantial property damage.

13. After installation is complete, attach the propane conversion label (in conversion kit bag) next to the boiler rating plate.
14. Perform complete start-up sequence (beginning on page 91), including check for gas leaks and checking for proper operation.
15. Reinstall jacket door.

Converting boiler to propane — EVG 155 *(continued)*

Figure 17 Installing the propane gas orifice (some details omitted for clarity)

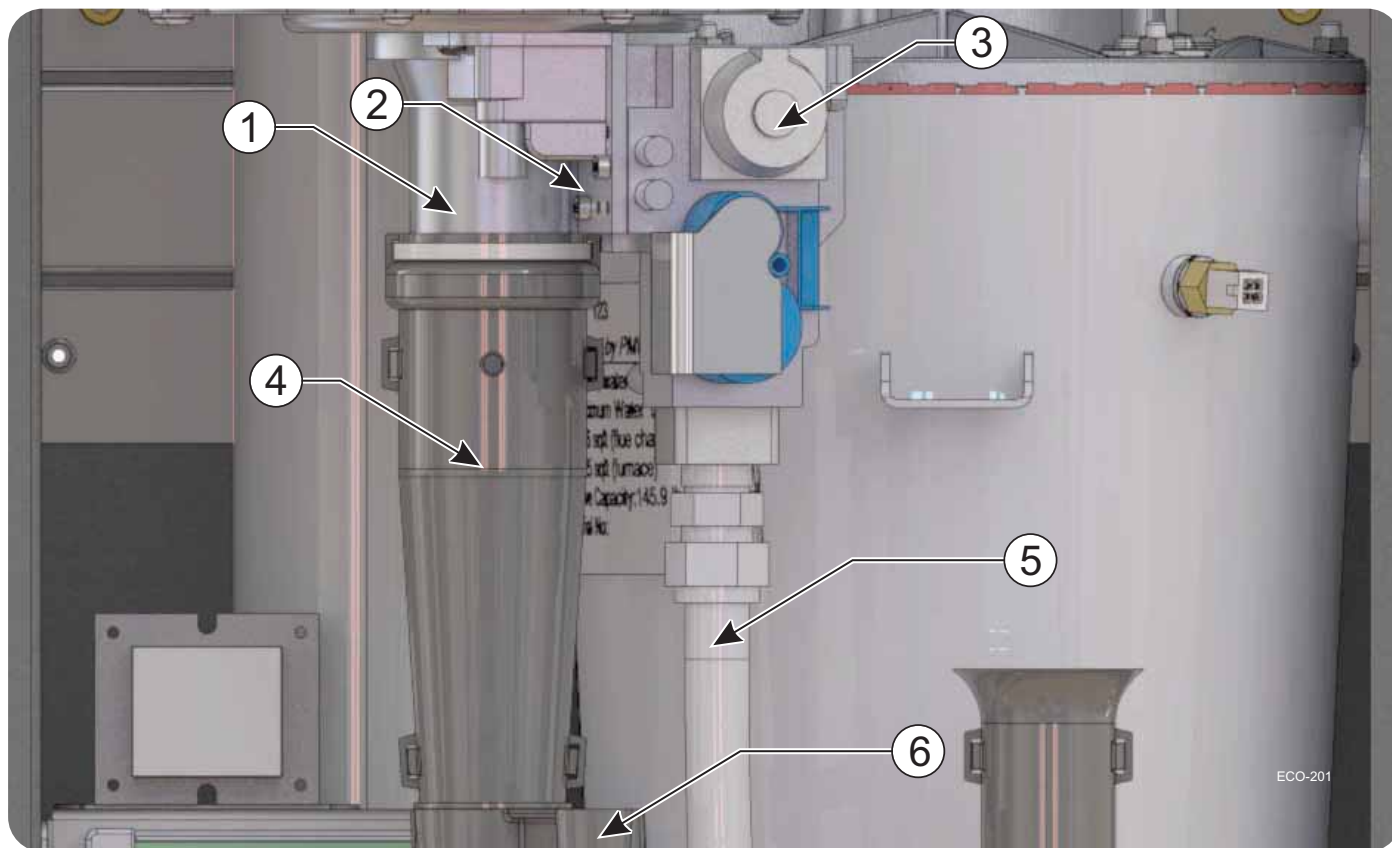

LEGEND for Figure 17 and Figure 18

- 1 Venturi (leave venturi attached to blower)
- 2 (3) hex-head screws, 5 mm hex (remove and retain)
- 3 Gas valve
- 4 Air silencer (leave connected to venturi)
- 5 Flexible gas line
- 6 Gas line to silencer bracket (rotate forward before disconnecting gas valve from venturi)
- 7 Propane orifice (in propane conversion kit envelope)
- 8 Rubber grommet (must be installed in valve for all applications) — make sure grommet is properly seated in valve before inserting the propane orifice

Figure 18 Gas valve and venturi

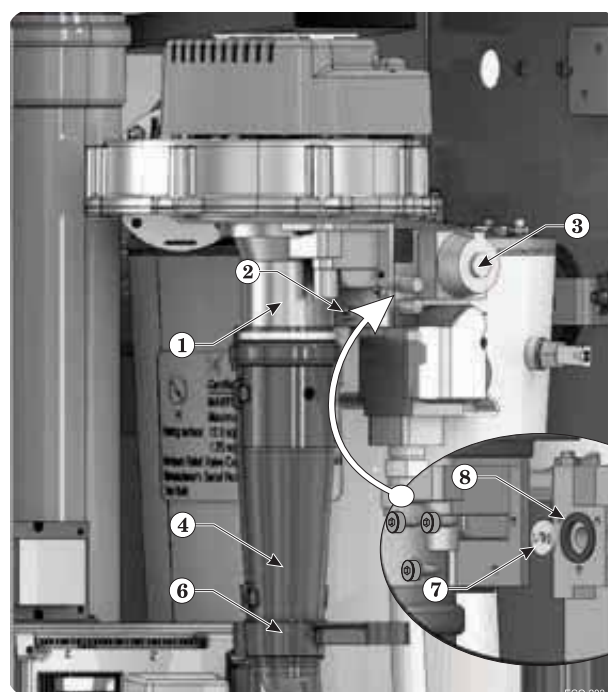

The jacket door must be in place during operation. DO NOT operate the boiler with the jacket door removed except for inspection and testing as directed in this manual.



Gas piping — sizing gas lines

NOTICE Boiler gas connection is ½" NPT. Size gas lines large enough to provide gas to all connected appliances.

Natural Gas:

Pipe sizing for natural gas

1. Size gas piping from meter outlet to entrance of boiler in accordance with Figure 19 and Figure 20.
2. Use total input of all connected appliances. Divide total input in Btuh by 1,000 to obtain cubic feet per hour of natural gas.
 - a. Pipe lengths in Figure 19 are equivalent length of straight pipe. Convert pipe fittings to equivalent lengths using data from Figure 20.
 - b. Figure 19 is only for natural gas with specific gravity 0.60, with a pressure drop through the gas piping as listed in the table.
 - c. For additional gas pipe sizing information, refer to ANSI Z223.1 NFPA 54 – latest edition (or Natural Gas and Propane Installation CAN/CSA B149.1 or B149.2 for Canadian installations).

Natural gas supply pressure

1. Pressure required at gas valve inlet pressure port:
 - a. Maximum: 13" (330 mm) w.c. with no flow (lockup).
 - b. Minimum gas pressure, with gas flowing (verify during boiler startup, while boiler is at high fire):
 - EVG 70: 3½" (89 mm) w.c.
 - EVG 110: 3½" (89 mm) w.c.
 - EVG 155: 3½" (89 mm) w.c.
 - c. Nominal gas pressure: 7.0" (178 mm) w.c.
2. Install 100% lockup gas pressure regulator in supply line if inlet pressure can exceed 13" w.c. at any time. Adjust lockup regulator for 13" w.c. maximum.

Propane Gas:

WARNING You must follow the instructions, beginning on page 15, to operate the boiler on propane. Failure to comply could result in severe personal injury, death or substantial property damage.

Pipe sizing for propane gas

1. Contact gas supplier to size pipes, tanks and 100% lockup gas pressure regulator.

Propane supply pressure

1. Adjust propane supply regulator provided by gas supplier for 13" (330 mm) w.c. maximum pressure.
2. Pressure required at gas valve inlet pressure port:
 - a. Maximum: 13" (330 mm) w.c. with no flow (lockup).
 - b. Minimum gas pressure, with gas flowing (verify during boiler startup, while boiler is at high fire):
 - EVG 70: 3½" (89 mm) w.c.
 - EVG 110: 3½" (89 mm) w.c.
 - EVG 155: 3½" (89 mm) w.c.
 - c. Nominal gas pressure: 11.0" (279 mm) w.c.

Figure 19 Pipe capacity for 0.60 specific gravity natural gas; pipe length is in equivalent feet.

Gas pipe total length, feet	Capacity						
	Cubic feet per hour, natural gas, 0.60 specific gravity Gas pressure 13" (330 mm) w.c. or less Pressure drop 0.3 inches (7.6 mm) w.c.						
	½"	¾"	1"	1¼"	1½"	2"	2½"
10	132	278	520	1050	1600	3050	4800
20	92	190	350	730	1100	2100	3300
30	73	152	285	590	890	1650	2700
40	NA	130	245	500	760	1450	2300
50	NA	115	215	440	670	1270	2000
75	NA	105	175	360	545	1020	1650
100	NA	96	150	305	460	870	1400
150	NA	90	120	250	380	710	1130

Figure 20 Equivalent lengths of straight pipe for typical gas line fittings.

Pipe size inches	Equivalent length, feet			
	90° Elbow		Tee	
	short radius	long radius	line flow	branch flow
½	3.6	2.2	1.7	4.2
¾	4.4	2.3	2.4	5.3
1	5.2	2.7	3.2	6.6
1¼	6.6	3.2	4.6	8.7
1½	7.4	3.4	5.6	9.9
2	8.5	3.6	7.7	12.0
2½	9.3	4.0	9.3	13.0



Venting/air piping — general

Any improper operation of the common venting system should be corrected so the installation conforms with the National Fuel Gas Code, ANSI Z223.1/NFPA 54 – latest edition, and/or the Natural Gas and Propane Installation Code, CAN/CSA B149.1. When resizing any portion of the common venting system, the common venting system should be resized to approach the minimum size as determined using the appropriate tables in Chapter 13 of the National Fuel Gas Code, ANSI Z223.1/NFPA 54 – latest edition, and/or the Natural Gas and Propane Installation Code, CAN/CSA B149.1.

⚠ DANGER Do not install the Evergreen® boiler into a common vent with any other appliance. This will cause flue gas spillage or appliance malfunction, resulting in possible severe personal injury, death or substantial property damage.

⚠ WARNING Existing common vent systems may be too large for the appliances remaining connected after the existing boiler is removed.

⚠ WARNING Failure to follow all instructions can result in flue gas spillage and carbon monoxide emissions, causing severe personal injury or death.

When removing a boiler from an existing common vent system

The Evergreen® boiler cannot be common vented with any other appliance. When an existing boiler is replaced with an Evergreen® boiler, the Evergreen® boiler CANNOT use the existing common vent. The boiler requires its own vent and air piping, as specified in this manual. This may cause a problem for the appliances that remain on the old common vent, because the vent may be too large. The following test is intended to check for proper operation of the appliances remaining on the old common vent system.

Vent system verification

Perform the test sequence below for **each** appliance remaining on the original common vent system. Operate each appliance individually, with other appliances turned off. This procedure will test whether the common vent system can properly vent each appliance.

Existing vent test procedure

(The following is intended to test whether the appliances remaining on an existing vent system will operate satisfactorily.)

1. Seal any unused openings in the common venting system.
2. Visually inspect the venting system for proper size and horizontal pitch and determine there is no blockage or restriction, leakage, corrosion or other deficiencies which could cause an unsafe condition.
3. Test vent system — Insofar as is practical, close all building doors and windows and all doors between the space in which the appliances remaining connected to the common venting system are located and other spaces of the building. Turn on clothes dryers and any appliance not connected to the common venting system. Turn on any exhaust fans, such as range hoods and bathroom exhausts, so they will operate at maximum speed. Do not operate a summer exhaust fan. Close fireplace dampers.
4. Place in operation the appliance being inspected. Follow the lighting instructions. Adjust thermostat so appliance will operate continuously.
5. Test for spillage at draft hood relief opening after 5 minutes of main burner operation. Use the flame of a match or candle, or smoke from a cigarette, cigar, or pipe.
6. After it has been determined that each appliance remaining connected to the common venting system properly vents when tested as outlined herein, return doors, windows, exhaust fans, fireplace dampers, and any other gas-burning appliance to their previous conditions of use.

⚠ WARNING You must pipe combustion air to the boiler air intake.

Install air inlet piping for the Evergreen® boiler as described in this manual.

The air termination fitting must be installed with the clearances and geometry relative to the vent outlet depicted in this manual to ensure that flue products do not enter the air intake.

Ensure that the combustion air will not contain any of the contaminants in Figure 16. Do not pipe combustion air near a swimming pool, for example. Avoid areas subject to exhaust fumes from laundry facilities. These areas will always contain contaminants.

Contaminated combustion air will damage the boiler, resulting in possible severe personal injury, death or substantial property damage.

Figure 21 Corrosive contaminants and sources

Products to avoid
Spray cans containing chloro/fluorocarbons
Permanent wave solutions
Chlorinated waxes/cleaners
Chlorine-based swimming pool chemicals
Calcium chloride used for thawing
Sodium chloride used for water softening
Refrigerant leaks
Paint or varnish removers
Hydrochloric acid/muriatic acid
Cements and glues
Antistatic fabric softeners used in clothes dryers
Chlorine-type bleaches, detergents, and cleaning solvents found in household laundry rooms
Adhesives used to fasten building products and other similar products
Excessive dust and dirt
Areas likely to have contaminants
Dry cleaning/laundry areas and establishments
Swimming pools
Metal fabrication plants
Beauty shops
Refrigeration repair shops
Photo processing plants
Auto body shops
Plastic manufacturing plants
Furniture refinishing areas and establishments
New building construction
Remodeling areas
Garages with workshops



Venting & air — general *(continued)*

Figure 22 Evergreen® venting and air piping — DIRECT VENT ONLY — OPTIONS and PIPING LIMITS

NOTICE The table below lists the acceptable vent/air pipe terminations described in this manual. Follow all instructions provided to install the vent/air system. **NOT SHOWN** below, but also approved, are the polypropylene piping and terminations listed in Figure 23, page 24. For these applications, use **ONLY** the manufacturers' parts listed and follow all instructions provided by the pipe manufacturer.

Evergreen® Model	Maximum vent and air pipe length = 100 feet for all applications										USE SWEEP ELBOWS ONLY	
	(Minimum length for all applications is 2 feet)											
	(All applications include allowance for the termination fittings plus one elbow in air piping and one elbow in vent piping).											
	See Figure 23, page 24 for material specifications See Figure 111, page 127 for part/kits numbers											
	Vent and air pipe sizes:											
	Maximum vent lengths apply for either 2" or 3" vent and air pipe.											
	If using 2" pipe, provide 3"x2" tapered reducers at boiler connections and at Weil-McLain vent/air cap or at concentric terminations.											
	Boilers will derate as vent/air pipe length increases — see rating data on Figure 124, page 139 for derate amounts.											
	SIDEWALL termination					VERTICAL termination						
	Separate pipes [Note 1]		PVC or PP Concentric [Note 1]		3" Weil-McLain PVC vent/air cap [Note 1]		Separate pipes [Note 1]		PVC or PP Concentric [Note 1]			Vertical vent, Side Air [Note 1]
See page 28		See page 30		See page 32		See page 34		See page 36		See page 38		
Size, inches	Materials Fig. 23, page 24	Size, inches	Materials Fig. 23, page 24	Size, inches	Materials Fig. 23, page 24	Size, inches	Materials Fig. 23, page 24	Size, inches	Materials Fig. 23, page 24	Size, inches	Materials Fig. 23, page 24	
70	2	PVC/PVC-DWV CPVC, PP, SS	2	PVC/PVC-DWV CPVC, PP, SS	2	PVC/PVC-DWV CPVC, PP, SS	2	PVC/PVC-DWV CPVC, PP, SS	2	PVC/PVC-DWV CPVC, PP, SS	2	PVC/PVC-DWV CPVC, PP, SS
	3	PVC/PVC-DWV CPVC, PP, SS	3	PVC/PVC-DWV CPVC, PP, SS	3	PVC/PVC-DWV CPVC, PP, SS	3	PVC/PVC-DWV CPVC, PP, SS	3	PVC/PVC-DWV CPVC, PP, SS	3	PVC/PVC-DWV CPVC, PP, SS
110	3	PVC/PVC-DWV CPVC, PP, SS	3	PVC Concentric only	–	–	3	PVC/PVC-DWV CPVC, PP, SS	3	PVC/PVC-DWV CPVC, PP, SS	3	PVC/PVC-DWV CPVC, PP, SS
155	3	PVC/PVC-DWV CPVC, PP, SS	3	PVC/PVC-DWV CPVC, SS, PP**	3	PVC/PVC-DWV CPVC, PP, SS	3	PVC/PVC-DWV CPVC, PP, SS	3	PVC/PVC-DWV CPVC, PP, SS	3	PVC/PVC-DWV CPVC, PP, SS
** Model 155 may be concentric sidewall vented using Centrotherm polypropylene pipe (Eco Systems InnoFlue® Single-wall) ONLY if using Centrotherm stainless steel concentric termination kit, part number ICWS3513.												

WARNING All elbows in vent and air piping must be sweep elbows ONLY. DO NOT use short-radius elbows. When transitioning to 3" to 2", use tapered reducer with 3" PVC nipple (L ≥ 6"). Do not use 3" to 2" bushing. Bushings will not seal in boiler adapters.

Equivalent feet for elbows (USE SWEEP ELBOWS ONLY) — deduct from max. equivalent length of piping (does not apply to termination fittings).

PVC • 7 feet per for each additional 90° sweep elbow or 45° elbow — If piping contains more than 1 elbow in air or vent piping, other than termination fittings.



PP • Centrotherm 3" = 6' 4" = 20' Duravent 3" = 17' 4" = 22'

Note 1:	Material abbreviations: PP = polypropylene, SS = AL29-4C stainless steel If using polypropylene or stainless pipe, provide adapters to for 3" boiler connections and for terminations, if required IPEX 3" PVC concentric vent kits can be used with standard PVC pipe, fittings and cement (ANSI/ASTM D1785) except if ULC S636 compliance is required. For ULC S636 compliance, all pipe, fittings and cement must be IPEX System 636. If using IPEX kits, use only IPEX product code 196006 for 3" venting. Contact Weil-McLain for ordering information and availability of Weil-McLain venting kits.
Note 2:	Use only Weil-McLain approved termination kits listed in Figure 111, page 127.



Venting & air — general *(continued)*

Figure 23 Vent and air piping materials — Use only the materials listed below, ensuring that all materials meet local codes (see Figure 111, page 127 for part/kit numbers)

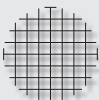
Item	Material	Standards for installations in:		
		United States	Canada (Note 2)	
Plastic piping materials		Vent or air piping	Vent piping	Air piping
Vent or air pipe & fittings	PVC schedule 40 (Note 1)	ANSI/ASTM D1785	ULC S636	ABS, PVC, PVC-DWV, CPVC or polypropylene
	PVC-DWV schedule 40 (Note 1)	ANSI/ASTM D2665	NA	
	CPVC schedule 40 (Note 1)	ANSI/ASTM F441	ULC S636	
	ABS-DWV schedule 40 (Intake Only)	ANSI/ASTM D2661	ULC S636	
PVC & ABS pipe cement & primer	PVC (Note 1)	ANSI/ASTM D2564/F656	ULC S636	Use only cement and primer suitable for piping material used
	CPVC (Note 1)	ANSI/ASTM F493	ULC S636	
	ABS schedule 40 (Note 1)	ANSI/ASTM D2235	ULC S636	
Polypropylene vent pipe, fittings, terminations and cement	Simpson-Duravent — Obtain all materials from M&G Simpson-Duravent Centrotherm Eco Systems InnoFlue® Single-wall — Obtain all materials from Centrotherm Note: See page 127 for correct appliance adapters to be used.	See manufacturer's literature for detailed information MUST USE LOCKING COLLAR ON EVERY JOINT	ULC S636	PVC, PVC-DWV, CPVC or polypropylene
AL29-4C stainless steel piping materials				
Vent pipe AL29-4C stainless steel	Heat Fab, Inc. — Saf-T-Vent® Z-Flex, Inc. — Z-Vent II Dura-Vent — FasNSeal™ Metal-Fab, Inc. — CORR/GUARD Centrotherm Eco Systems — InnoFlue®	Certified for Category IV and direct vent appliance venting	Certified for Category IV and direct vent appliance venting	
Weil-McLain stainless steel bird screens, 2" or 3" (purchase separately) — see Figure 111, page 127 for part numbers				
Note 1:	Weil-McLain concentric vent kits are made from PVC pipe and fittings.	⚠ WARNING ADAPTERS — AL29-4C piping — Install a PVC-to-stainless adapter supplied by the AL29-4C stainless pipe manufacturer at the 3" PVC boiler vent connection and at the termination (if using Weil-McLain plate or concentric PVC termination). ADAPTERS — Polypropylene piping — Provide adapters from polypropylene pipe to the 3" PVC connections at the boiler and at terminations, if required (Weil-McLain sidewall plate, for example). ADAPTERS — If using 2" piping, where approved for the application, provide adapters for the 3" PVC boiler connections and at the terminations, if required (Weil-McLain sidewall plate, for example)		
Note 2:	System 636 PVC concentric terminations utilize PVC pipe/fittings certified to ULC S636. If ULC S636 compliance is required, use only System 636 pipe, fittings and cement.			
⚠ WARNING	DO NOT mix piping from different pipe manufacturers unless using adapters specifically designed for the purpose by the manufacturer.			
⚠ WARNING	Every joint on polypropylene vent piping must include a locking collar.			
⚠ WARNING	DO NOT use cellular core PVC (ASTM F891), cellular core CPVC, or Radel® (polyphenolsulfone) in venting systems.			
⚠ WARNING	DO NOT cover non-metallic vent pipe and fittings with thermal insulation.			
		⚠ WARNING	USE SWEEP ELBOWS FOR ALL VENT AND AIR PIPING — DO NOT use short radius elbows for vent or air piping. Boiler performance could be affected.	
	⚠ WARNING	ALL vent and air pipes require a BIRD SCREEN at each termination . Most kits do not include the bird screens. Purchase bird screens separately from Weil-McLain or vent kit supplier if not included. [Note — bird screening is integral to the 3" PVC Weil-McLain sidewall vent cap, available for purchase from Weil-McLain. No additional screening is required.]		



Commonwealth of Massachusetts installations

Commonwealth of Massachusetts — When the boiler is installed within the Commonwealth of Massachusetts, the boiler must be installed by a licensed plumber or gas fitter. Read and comply with the instructions below.

- (a) For all sidewall horizontally-vented gas-fueled equipment installed in every dwelling, building or structure used in whole or in part for residential purposes, including those owned or operated by the Commonwealth and where the side wall exhaust vent termination is less than seven (7) feet above finished grade in the area of the venting, including but not limited to decks and porches, the following requirements shall be satisfied:
1. **INSTALLATION OF CARBON MONOXIDE DETECTORS.** At the time of installation of the side wall horizontal vented gas fueled equipment, the installing plumber or gas fitter shall observe that a hard wired carbon monoxide detector with an alarm and battery back-up is installed on the floor level where the gas equipment is to be installed. In addition, the installing plumber or gas fitter shall observe that a battery operated or hard wired carbon monoxide detector with an alarm is installed on each additional level of the dwelling, building or structure served by the side wall horizontal vented gas fueled equipment. It shall be the responsibility of the property owner to secure the services of qualified licensed professionals for the installation of hard wired carbon monoxide detectors.
 - a. In the event that the side wall horizontally vented gas fueled equipment is installed in a crawl space or an attic, the hard wired carbon monoxide detector with alarm and battery back-up may be installed on the next adjacent floor level.
 - b. In the event that the requirements of this subdivision can not be met at the time of completion of installation, the owner shall have a period of thirty (30) days to comply with the above requirements; provided, however, that during said thirty (30) day period, a battery operated carbon monoxide detector with an alarm shall be installed.
 2. **APPROVED CARBON MONOXIDE DETECTORS.** Each carbon monoxide detector as required in accordance with the above provisions shall comply with NFPA 720 and be ANSI/UL 2034 listed and IAS certified.
 3. **SIGNAGE.** A metal or plastic identification plate shall be permanently mounted to the exterior of the building at a minimum height of eight (8) feet above grade directly in line with the exhaust vent terminal for the horizontally vented gas fueled heating appliance or equipment. The sign shall read, in print size no less than one-half (1/2) inch in size, "GAS VENT DIRECTLY BELOW. KEEP CLEAR OF ALL OBSTRUCTIONS."
 4. **INSPECTION.** The state or local gas inspector of the side wall horizontally vented gas fueled equipment shall not approve the installation unless, upon inspection, the inspector observes carbon monoxide detectors and signage installed in accordance with the provisions of 248 CMR 5.08(2)(a) 1 through 4.
- (b) **EXEMPTIONS:** The following equipment is exempt from 248 CMR 5.08(2)(a)1 through 4:
1. The equipment listed in Chapter 10 entitled "Equipment Not Required To Be Vented" in the most current edition of NFPA 54 as adopted by the Board; and
 2. Product Approved side wall horizontally vented gas fueled equipment installed in a room or structure separate from the dwelling, building or structure used in whole or in part for residential purposes.
- (c) **MANUFACTURER REQUIREMENTS — GAS EQUIPMENT VENTING SYSTEM PROVIDED.** When the manufacturer of Product Approved side wall horizontally vented gas equipment provides a venting system design or venting system components with the equipment, the instructions provided by the manufacturer for installation of the equipment and the venting system shall include:
1. Detailed instructions for the installation of the venting system design or the venting system components; and
 2. A complete parts list for the venting system design or venting system.
- (d) **MANUFACTURER REQUIREMENTS — GAS EQUIPMENT VENTING SYSTEM NOT PROVIDED.** When the manufacturer of a Product Approved side wall horizontally vented gas fueled equipment does not provide the parts for venting the flue gases, but identifies "special venting systems", the following requirements shall be satisfied by the manufacturer:
1. The referenced "special venting system" instructions shall be included with the appliance or equipment installation instructions; and
 2. The "special venting systems" shall be Product Approved by the Board, and the instructions for that system shall include a parts list and detailed installation instructions.
- (e) A copy of all installation instructions for all Product Approved side wall horizontally vented gas fueled equipment, all venting instructions, all parts lists for venting instructions, and/or all venting design instructions shall remain with the appliance or equipment at the completion of the installation.



Vent termination requirements

Figure 24 The vent termination must be located to meet all requirements below (also applies to vertical vent terminations). The minimum distance from adjacent public walkways, adjacent buildings, openable windows and building in the National Fuel Gas Code, ANSI Z223.1/NFPA 54 and/or the Natural Gas and Propane Installation Code, CAN/CSA B149.1. The vent termination clearances below are for U.S.A., for Canadian vent termination clearances please refer to the requirements of CAN/CSA B149.1 Natural Gas and Propane Installation Code. Consideration should be given to avoid possible damage caused by vent plumes and condensate when choosing a venting configuration and location. Maintain a minimum clearance of 4 ft. (1.22m) horizontally from, and in no case above or below, unless a 4 ft. (1.22m) horizontal distance is maintained, from electrical meters, gas meters, regulators, and relief equipment.



MINIMUM CLEARANCES

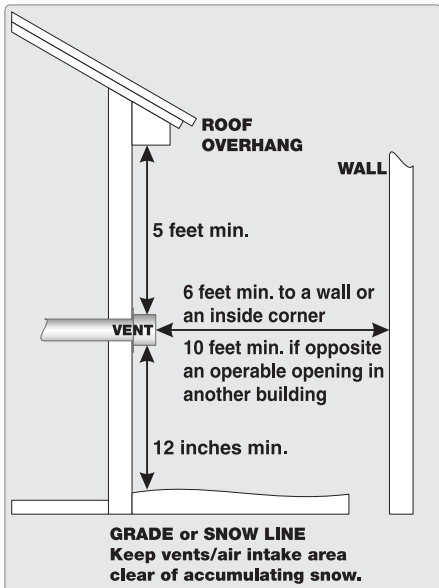
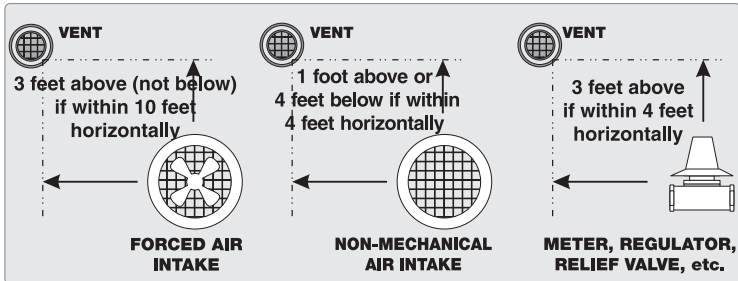
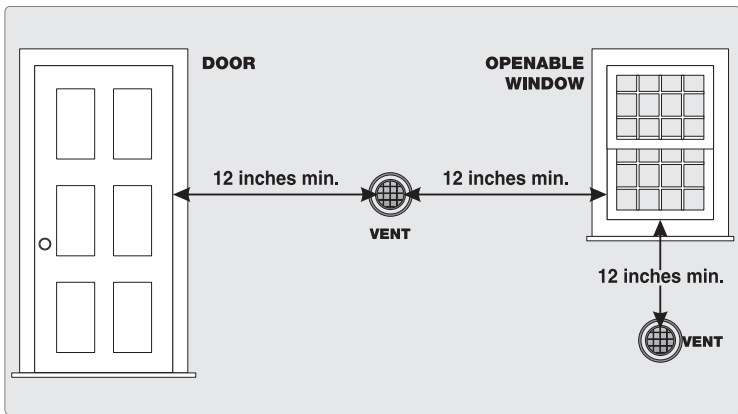

DO NOT TERMINATE:

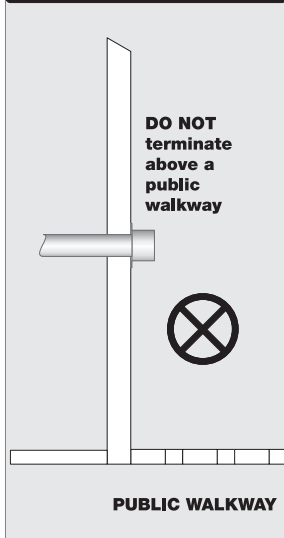

DO NOT TERMINATE:

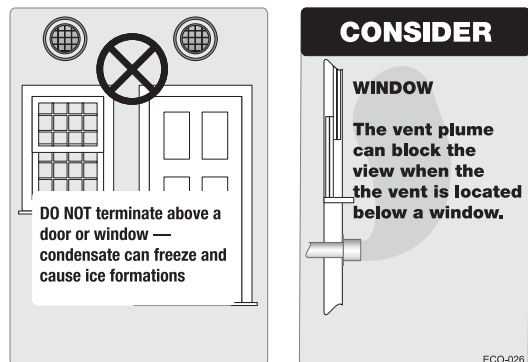
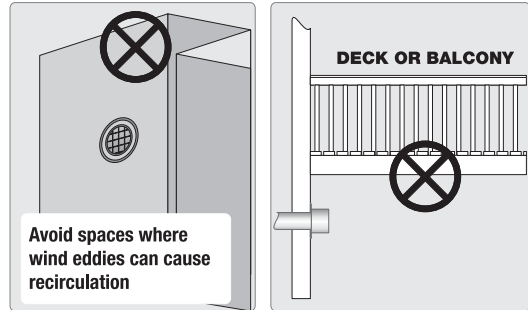
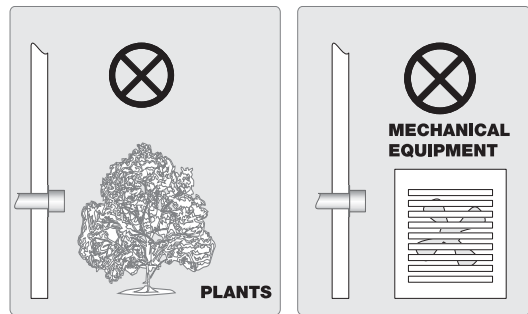

ECO-026



Boiler room air openings

Figure 25 Combustion and ventilation air openings for Direct Vent installations, also follow the National Fuel Gas Code, ANSI Z223.1/NFPA 54 - latest edition, and/or Natural Gas and Propane Installation Code, CAN/CSA B149.1 or applicable provisions of the local building codes.

WARNING The Evergreen® boiler CANNOT be in the same space with other appliances if clearances around the Evergreen® are less than the recommended service clearances shown in Figure 1, page 9.

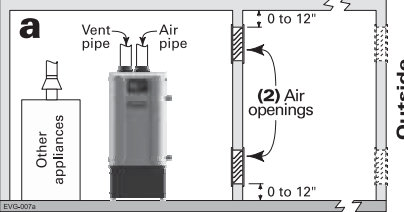
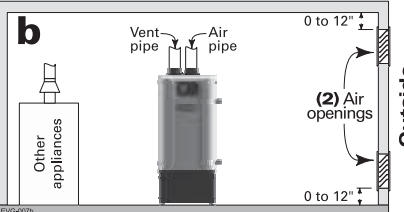
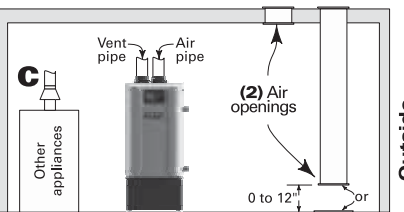
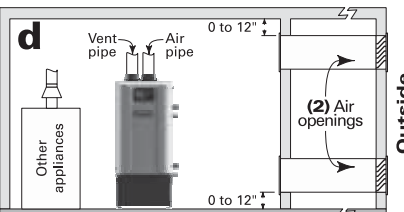
<p align="center">Air openings</p> <p>The required air opening sizes below are FREE AREA, after reduction for louver obstruction. Note the exception below for large spaces.</p>	<p align="center">Evergreen® boiler WITH other appliances in room</p>	<p align="center">Evergreen® boiler WITHOUT other appliances in room</p>
 <p>a</p>	<p>TWO openings, each at least: 1 square inch per 1,000 Btuh of all other appliances in the room (Unless specified otherwise by appliance manufacturer)</p>	
 <p>b</p>	<p>TWO openings, each at least: 1 square inch per 4,000 Btuh of all other appliances in the room — OR — ONE opening **, each at least: 1 square inch per 3,000 Btuh of all other appliances in the room (Unless specified otherwise by appliance manufacturer)</p>	<p>NO openings are required if the boiler installation provides at least the recommended service clearances shown in Figure 1, page 9.</p>
<p align="center">Outside or ventilated attic</p>  <p>c</p>	<p>TWO openings, each at least: 1 square inch per 4,000 Btuh of all other appliances in the room — OR — ONE opening **, each at least: 1 square inch per 3,000 Btuh of all other appliances in the room (Unless specified otherwise by appliance manufacturer)</p>	<p><i>If the space is smaller than Figure 1, page 9, provide openings ONLY as shown in Figure 2, page 9.</i> Each opening must have a free area no less than 1 square inch per 1,000 Btuh input of the boiler.</p>
 <p>d</p>	<p>TWO openings, each at least: 1 square inch per 2,000 Btuh of all other appliances in the room — OR — ONE opening **, each at least: 1 square inch per 3,000 Btuh of all other appliances in the room (Unless specified otherwise by appliance manufacturer)</p>	
<p>** NOTICE: Requirements for using the SINGLE air opening option.</p>	<p>A single combustion air opening can be used for cases b, c or d above (EVG with other appliances in room only), sized as listed, provided that:</p> <ul style="list-style-type: none"> • The single opening must communicate directly to the outdoors or to a space that communicates directly with outdoors (NOT to an interior space). • The top of the opening must be within 12 inches of the ceiling. • The free area of the opening must be at least equal to the sum of the areas of all equipment vent connectors in the space. 	
<p>SPECIAL EXCEPTION FOR LARGE SPACES (EVG WITH other appliances in room only):</p>	<p>NO combustion air openings are needed if the boiler (and other appliances) are installed in a space with a volume NO LESS than 50 cubic feet per 1,000 Btuh of all appliances in the space. That is, total the input of all appliances in MBH (1,000's of Btuh), then multiply this total times 50. The building MUST NOT be of tight construction. Example: For a total input of 500 MBH (500,000 Btuh), the minimum volume would be 50 x 500 = 25,000 cubic feet.</p>	



DIRECT VENT — Sidewall with separate pipes

Allowable vent/air pipe materials & lengths

▲WARNING Use only the vent materials and kits listed in Figure 23, page 24. Provide pipe adapters if specified.

1. Locate the termination such that the total air piping and vent piping from the boiler to the termination will not exceed the maximum length given in Figure 22, page 23.

Polypropylene For polypropylene applications, comply with any additional requirements in the vent system manufacturer's instructions. Provide 3" PVC transition pieces at the boiler vent and air connections. Install a locking collar at every joint.

AL29-4C S.S. For AL29-4C vent pipe applications, comply with any additional requirements in the vent system manufacturer's instructions. Provide a 3" PVC transition piece at the boiler vent connection. The air piping must be PVC or CPVC. Provide a 3" PVC transition piece at the boiler air connection if using 2" air piping.

Determine termination location

1. The air and vent terminations must be installed as shown in Figure 26 and Figure 28, page 29.
2. The terminations must comply with clearances and limitations shown in Figure 24, page 26.
3. Locate the terminations so they are not likely to be damaged by foreign objects, such as stones or balls, or subject to buildup of leaves or sediment.

▲WARNING Do not exceed the maximum lengths of the outside vent piping shown in Figure 26. Excessive length exposed to the outside could cause freezing of condensate in the vent pipe, resulting in potential boiler shutdown. In extremely cold climates, install an insulated chase around the vent piping, particularly if using longer lengths. The chase must allow for inspection of the vent pipe, and insulation must be protected from water.

Multiple vent/air terminations

1. When terminating multiple boilers, terminate each vent/air connection as described in this manual.

▲WARNING All vent pipes and air inlets must terminate at the same height to avoid possibility of severe personal injury, death or substantial property damage.

Figure 26 INSTALLATION SEQUENCE — Separate pipes sidewall

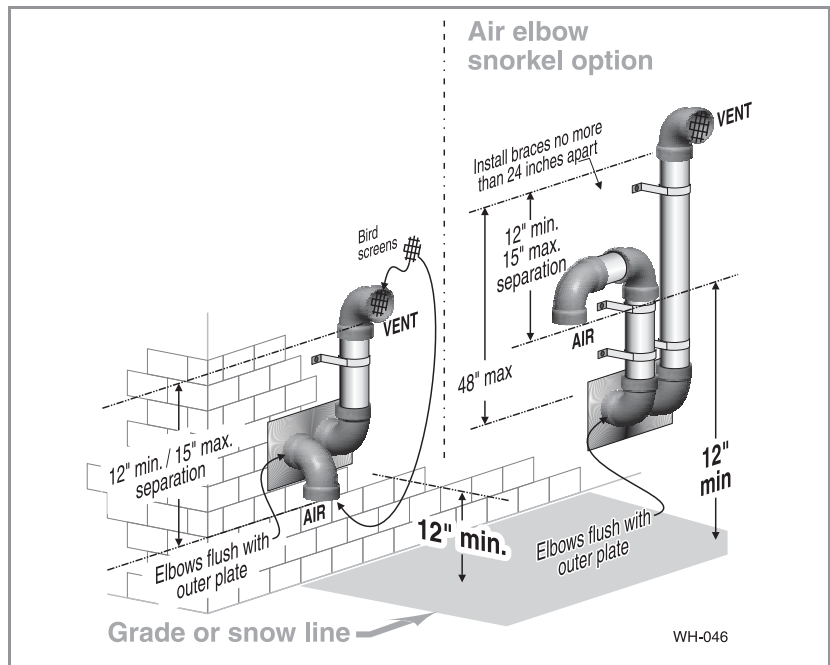

- Step 1** Read and follow all instructions in this manual. **DO NOT proceed with vent/air installation until you have read page 22 through page 27.** **Polypropylene AL29-4C S.S.** See notices at left.
- Step 2** Install the boiler in a location that allows proper routing of all vent and air piping to the selected sidewall location.
- Step 3** Make sure the selected sidewall termination location complies with Figure 24, page 26. (Multiple boiler sidewall plates must also comply with Figure 27, page 29.)
- Step 4** Use only the vent materials listed in Figure 23, page 24. Provide pipe adapters where required. Vent piping and air piping lengths must not exceed the values shown in Figure 22, page 23.
- Step 5** Prepare the sidewall penetrations and secure the sidewall plates as instructed in this section. See "Prepare wall penetrations" on page 29. **Polypropylene AL29-4C S.S.** See notices at left.
- Step 6** The air piping must terminate in a **down-turned elbow** as shown above. The vent piping must terminate in an **elbow pointed outward or away from the air inlet** as shown above. See illustration above.
- Step 7** Install vent and air piping between the boiler and the sidewall openings. Slope horizontal piping downward toward the boiler at least 1/4 inch per foot. See page 41 for general guidelines. **Polypropylene AL29-4C S.S.** See notices at left.
- Step 8** Install pipe supports every 5 feet on both the horizontal and vertical runs. Install a hanger support within 6 inches of any upturn in the piping, or per vent pipe manufacturer's instructions. **Polypropylene AL29-4C S.S.** See notices at left.
- Step 9** Attach the vent termination exterior piping: Use either of the configurations shown above, as needed to ensure clearance above grade or snow line.
- Step 10** The vent and air pipes may run up as high as 4 feet with no enclosure. The vent and air pipes must be secured with braces, and all clearances and lengths must be maintained. Space braces no further than 24 inches apart.
- Step 11** External venting greater than 4 feet requires an insulated enclosure around the vent and air pipes. The vent and air terminations must exit through the enclosure as shown in the illustration above, maintaining all required clearances.



▲WARNING **USE SWEEP ELBOWS FOR ALL VENT AND AIR PIPING** — DO NOT use short radius elbows for vent or air piping. Boiler performance could be affected.



DIRECT VENT — Sidewall with separate pipes *(continued)*

Polypropylene AL29-4C S.S. See notices on previous page.

2. Place wall penetrations to obtain minimum clearances shown in Figure 27 for U. S. installations. For Canadian installations, provide clearances required by CSA B149.1 or B149.2 Installation Code and a ULC S636 compliant vent kit.
3. The air inlet of a boiler is part of a direct vent connection. It is not classified as a forced air intake with regard to spacing from adjacent boiler vents.

Prepare wall penetrations

1. Air pipe penetration:
 - a. Cut a hole for the air pipe. Size the air pipe hole as close as desired to the air pipe outside diameter.
2. Vent pipe penetration:
 - a. Cut a hole for the vent pipe. For either combustible or noncombustible construction, size the vent pipe hole at least 0.4" larger than the vent pipe diameter.
 - b. Insert a corrosion resistant metal thimble in the vent pipe hole as shown in Figure 28.
3. Use the provided paper template for correct location of hole centers.
4. Use of a sidewall termination plate is REQUIRED.
 - a. Kits for several vent sizes are available from Weil-McLain. See "VENT/AIR PARTS AND KITS" on page 127.
 - b. Plate may be field fabricated from corrosion resistant material of sufficient strength. Plate must allow venting to maintain minimum clearance to combustibles.

WARNING Ensure that the plate material is strong enough to prevent the termination from being pushed inward if struck or pushed from the outside.

5. Follow all local codes for isolation of vent pipe when passing through floors or walls.
6. Seal exterior openings thoroughly with exterior caulk.

Termination and fittings

1. Prepare the vent termination elbow and the air termination elbow by inserting bird screens. (See Figure 26, page 28.) Bird screens must be purchased separately. See the parts list at the end of this manual for part numbers.
2. Secure the elbows so they will butt against the sidewall termination plate.
3. When completed, the air termination coupling must be oriented at least 12 inches below the vent termination and at least 12 inches above grade or snow line as shown in Figure 26, page 28.
4. You can orient the vent termination elbow either directly outward or 90 degrees away from the air inlet elbow as shown in Figure 26, page 28.
5. Maintain the required dimensions of the finished termination piping as shown in Figure 26, page 28.
6. For multiple boiler terminations, see Figure 27.
7. Do not extend exposed vent pipe outside of building more than shown in this document. Condensate could freeze and block vent pipe.

NOTICE If extending the vent and air pipes out from the wall, install a coupling on each pipe. Mount the piping with the coupling flush with the outer plate.

Figure 27 Multiple separate pipes sidewall terminations — maintain vertical spacing between vent and air fittings shown in Figure 26, page 28

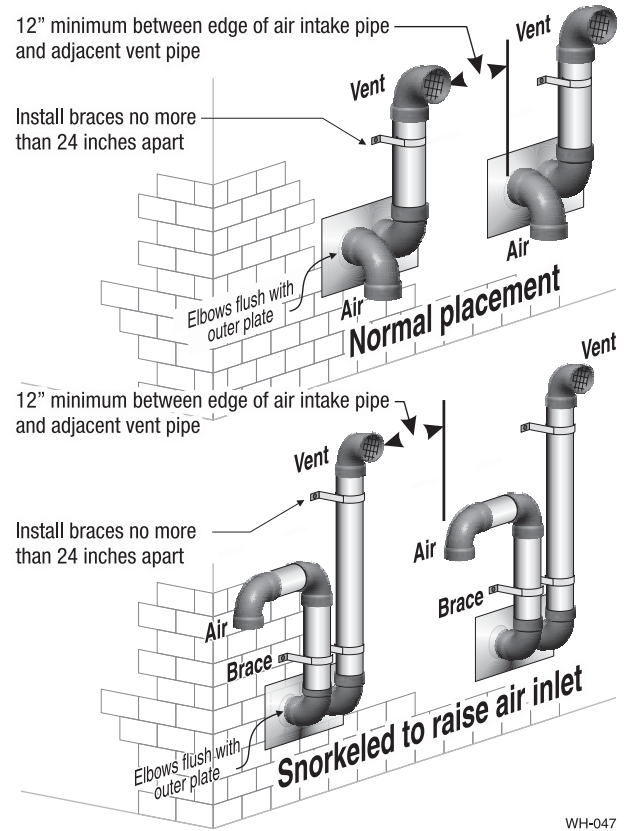

WH-047

Figure 28 Sidewall termination assembly — using separate pipes

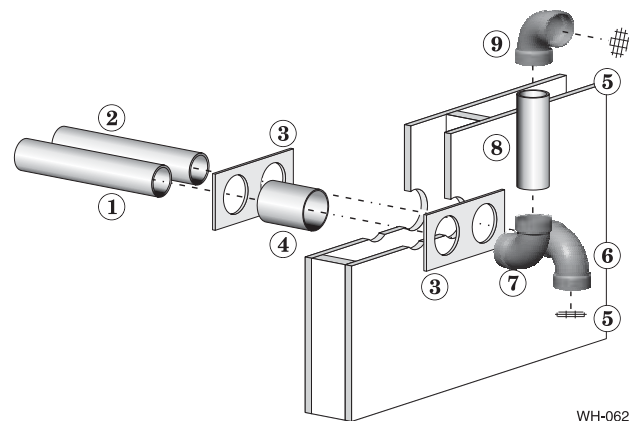

WH-062

1 Vent piping	4 Corrosion resistant thimbles, by installer
2 Air piping	5 Bird screen, by installer
3 Sidewall termination plates: for 3" PVC, use plates supplied with boiler in W-M vent/air plate kit; for 3" AL29-4C or 2" PVC, purchase optional sidewall separate pipes plate kit	6 Air inlet elbow
	7 Elbow
	8 Nipple
	9 Elbow (vent termination)



DIRECT VENT — Sidewall concentric

Allowable vent/air pipe materials & lengths

1. The concentric termination kit must be purchased separately.

▲WARNING Use only the vent materials and kits listed in Figure 23, page 24. Provide pipe adapters if specified.

2. Locate the termination such that the total air piping and vent piping from the boiler to the termination will not exceed the maximum length given in Figure 22, page 23.
3. This termination requires a 45-degree elbow that is not supplied with the termination kit. The maximum vent/air pipe lengths include allowance for this elbow.

Polypropylene For polypropylene applications, comply with any additional requirements in the vent system manufacturer's instructions. Provide 3" PVC transition pieces at the boiler vent and air connections and at the termination if using a 3" PVC concentric vent kit. Install a locking collar at every joint.

AL29-4C S.S. For AL29-4C vent pipe applications, comply with any additional requirements in the vent system manufacturer's instructions. Provide a 3" PVC transition at the boiler vent connection. Air pipe must be PVC or CPVC. Provide a 3" PVC transition at the boiler air connection if using 2" air pipe. Provide transition pieces to PVC at the vent and air pipe termination connections.

Determine termination location

1. The concentric termination kit must be installed as shown in Figure 31, page 31.
2. The termination must comply with clearances and limitations shown in Figure 24, page 26.
3. Locate the termination so it is not likely to be damaged by foreign objects, such as stones or balls, or subject to buildup of leaves or sediment.

Multiple vent/air terminations

1. When terminating multiple boilers, install each concentric termination as described in this manual.

▲WARNING All vent pipes and air inlets must terminate at the same height to avoid possibility of severe personal injury, death or substantial property damage.

2. Place wall penetrations to obtain minimum clearance as shown in Figure 30, page 31 for U. S. installations. For Canadian installations, provide clearances required by CSA B149.1 or B149.2 Installation Code and a ULC S636 compliant vent kit.
3. The air inlet of a boiler is part of a direct vent connection. It is not classified as a forced air intake with regard to spacing from adjacent boiler vents.

Figure 29 INSTALLATION SEQUENCE — Concentric horizontal

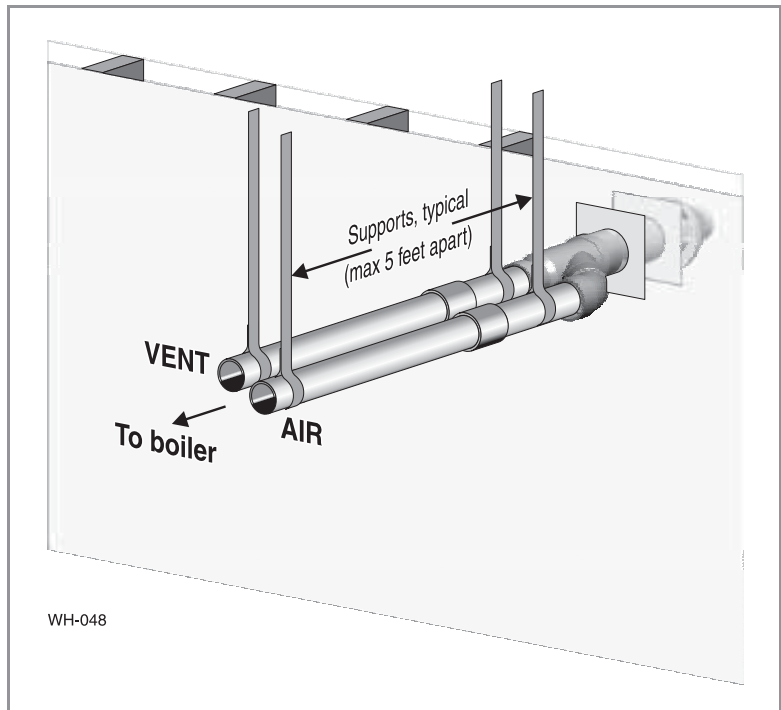

- Step 1** Read and follow all instructions in this manual. **DO NOT proceed with vent/air installation until you have read page 22 through page 27.** **Polypropylene** **AL29-4C S.S.** See notices at left.
- Step 2** Install the boiler in a location that allows proper routing of all vent and air piping to the selected sidewall location.
- Step 3** Make sure the selected sidewall termination location complies with Figure 24, page 26. (Multiple boiler concentric terminations must also comply with Figure 30, page 31.)
- Step 4** Use only the vent materials listed in Figure 23, page 24. Provide pipe adapters where required.
- Step 5** Vent piping and air piping lengths must not exceed the values shown in Figure 22, page 23.
- Step 6** The concentric termination must be assembled and installed before piping from the boiler to the termination.
- Step 7** Prepare the sidewall penetration — assemble the concentric termination kit and secure the cover plates as instructed in this section. Provide the supports indicated and mount the termination assembly. See “Install termination — concentric pipes” on page 31. **Polypropylene** **AL29-4C S.S.** See notices at left.
- Step 8** Install vent and air piping between the boiler and the concentric vent/air termination. Slope horizontal piping downward toward the boiler at least 1/4 inch per foot. See page 41 for general guidelines.
- Step 9** Install pipe supports every 5 feet on both the horizontal and vertical runs. **Polypropylene** **AL29-4C S.S.** See notices at left.
- Step 10** Install a hanger support within 6 inches of any upturn in the piping. **Polypropylene** **AL29-4C S.S.** See notices at left.



▲WARNING **USE SWEEP ELBOWS FOR ALL VENT AND AIR PIPING** — DO NOT use short radius elbows for vent or air piping. Boiler performance could be affected.



DIRECT VENT — Sidewall concentric (continued)

Polypropylene AL29-4C S.S. See notices on previous page.

Install termination — concentric pipes

1. Assemble the vent termination as described for concentric terminations, on page 40.

WARNING If necessary, you can shorten the lengths of the inner and outer pipes for a shorter finished assembly. But you must ensure the pipes butt correctly at both ends. Failure to properly assemble the concentric termination can result in flue gas recirculation, causing possible severe personal injury or death.

2. Wall penetration:
 - a. Preferably, use a thimble with a 4½-inch hole. If not using a thimble, carefully use a hole saw to cut a hole not larger than 4¾ inches in diameter through the wall. The finished hole must provide a solid stop for the rain cap ribs, as shown in the inset to Figure 31.

WARNING Ensure that the wall material is strong enough to prevent the rain cap from being pushed inward if struck or pushed from the outside.

3. Secure the termination in place so the rain cap will butt against the outside wall or outer thimble plate as shown in Figure 31.
4. Before beginning vent and air piping from the boiler to the concentric termination, mount and secure the concentric termination as shown in Figure 31.

WARNING The vent and air piping must be securely supported, and must not rest its weight on the boiler fittings. Failure to properly support the vent and air piping could result in vent piping damage, resulting in possible severe personal injury, death or substantial property damage.

The supports/bracing used must support the termination assembly to prevent slippage or movement. See instructions provided with concentric kit for details.

The clamps used on the outside of the termination pipe must not cut into the pipe or contain sharp edges that could cause a crack to form.

WARNING When inserting the partially-assembled termination kit through the wall penetration, wrap plastic or other protection over the end of the exposed assembly to prevent debris from entering the pipes. If the air passages become blocked, the boiler will not operate. Once the rain cap has been cemented to the assembly, there is no way to correct the problem. The assembly would have to be replaced if it were cut to be removed and cleaned. Altering the assembly in any way could result in severe personal injury or death due to toxic flue product emissions.

WARNING If using AL29-4C stainless vent pipe, use the vent pipe manufacturer's PVC adapter if connecting to a PVC concentric vent attachment.

5. After the assembly has been positioned in the opening and all supports have been attached, install a bird screen (purchased separately if not included with the kit) and rain cap as follows:
 - a. Place the bird screen on the end of the inner pipe as in Figure 44, page 40, or per concentric kit instructions for polypropylene kits.
 - b. Cement the rain cap in place as shown.

Figure 30 Termination location — concentric termination — multiple boilers — clearance from vent of one to air intake of the next

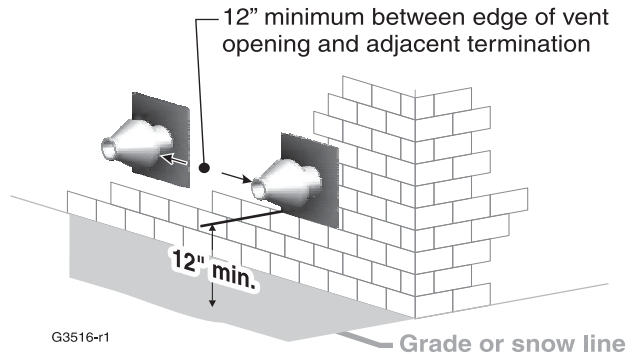
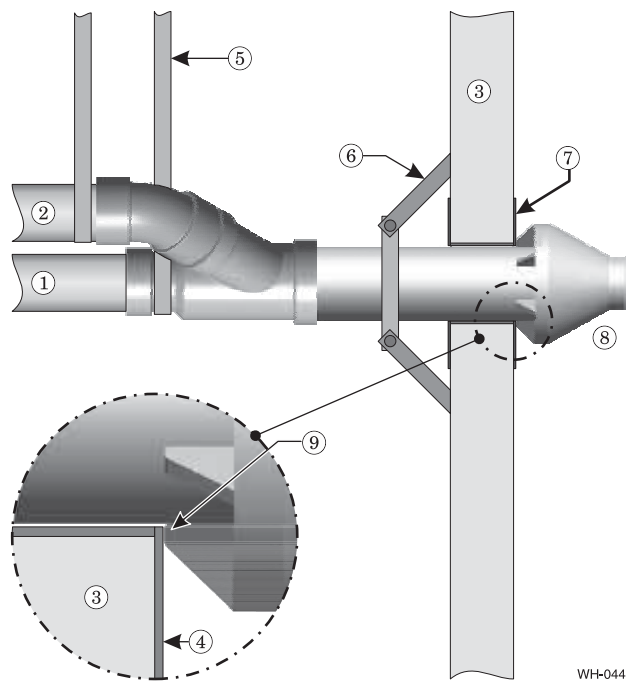

Figure 31 Installing and supporting the concentric sidewall vent assembly



LEGEND	
1	Vent pipe
2	Air pipe
3	Wall
4	Outer thimble plate
5	Supports every 5 feet or per vent pipe mfg's instructions
6	Wall brace, by installer, (or see vent pipe mfg's instructions)
7	Thimble, by installer
8	Rain cap
9	Rain cap ribs must butt against outer thimble plate or wall opening



DIRECT VENT — Sidewall with W-M vent/air plate

Allowable vent/air pipe materials & lengths

WARNING Use only the vent materials and kits listed in Figure 23, page 24. Provide pipe adapters if specified.

1. Locate the termination such that the total air piping and vent piping from the boiler to the termination will not exceed the maximum length given in Figure 22, page 23.

Polypropylene For polypropylene applications, comply with any additional requirements in the vent system manufacturer's instructions. Provide 3" PVC transition pieces at the boiler vent and air connections and at the vent termination. Install a locking collar at every joint.

AL29-4C S.S. For AL29-4C vent pipe applications, comply with any additional requirements in the vent system manufacturer's instructions. Provide 3" PVC transition pieces at the boiler and at the vent and air terminations. (The air pipe must be PVC or CPVC.)

Determine termination location

1. The vent/air cap must be installed as shown in Figure 35, page 33.
2. The termination must comply with clearances and limitations shown in Figure 24, page 26.
3. Locate the termination so it is not likely to be damaged by foreign objects, such as stones or balls, or subject to buildup of leaves or sediment.

Multiple vent/air terminations or termination adjacent to other appliance terminations

1. When terminating multiple boilers, terminate each vent/air connection as described in this manual.

WARNING All vent pipes and air inlets must terminate at the same height to avoid possibility of severe personal injury, death or substantial property damage.

2. Place wall penetrations to obtain minimum clearance as shown in for U. S. installations. For Canadian installations, provide clearances required by CSA B149.1 or B149.2 Installation Code and a ULC S636 compliant vent kit.
3. The air inlet of a boiler is part of a direct vent connection. It is not classified as a forced air intake with regard to spacing from adjacent boiler vents.

WARNING For terminations of other appliances, provide at least the clearance shown. The installation must also comply with the manual for the other appliances.

Figure 32 INSTALLATION — W-M sidewall vent/air plate

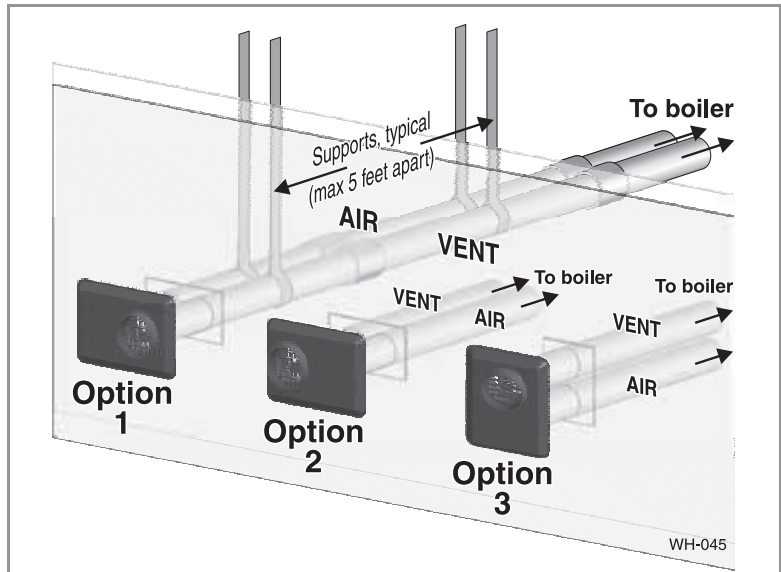

Vent/air pipes and vent/air can be oriented as option 1, 2, or 3. DO NOT mount with plate vertical and vent outlet down.

- Step 1** Read and follow all instructions in this manual. **DO NOT proceed with vent/air installation until you have read page 22 through page 27.** **Polypropylene AL29-4C S.S.** See notices at left.
- Step 2** Install the boiler in a location that allows proper routing of all vent and air piping to the selected sidewall location.
- Step 3** Make sure the selected sidewall termination location complies with Figure 24, page 26. (Multiple boiler sidewall plates must also comply with Figure 33, page 33.)
- Step 4** Use only the vent materials listed in Figure 23, page 24. Provide pipe adapters where required.
- Step 5** Vent piping and air piping lengths must not exceed the values shown in Figure 22, page 23.
- Step 6** Prepare the sidewall penetrations and secure the sidewall plates as instructed in this section. See “Install Weil-McLain vent/air cap” on page 33.
- Step 7** The Weil-McLain plate termination must be installed before piping from the boiler to the termination.
- Step 8** Install vent and air piping between the boiler and the vent/air termination plate. Slope horizontal piping downward toward the boiler at least 1/4 inch per foot. See page 41 for general guidelines.
- Step 9** Install pipe supports every 5 feet on both the horizontal and vertical runs, or per vent pipe manufacturer's instructions. **Polypropylene AL29-4C S.S.** See notices at left.
- Step 10** Install a hanger support within 6 inches of any upturn in the piping, or per vent pipe manufacturer's instructions. **Polypropylene AL29-4C S.S.** See notices at left.



WARNING USE SWEEP ELBOWS FOR ALL VENT AND AIR PIPING — DO NOT use short radius elbows for vent or air piping. Boiler performance could be affected.



DIRECT VENT — Sidewall with W-M vent/air plate *(continued)*

Install Weil-McLain vent/air cap

⚠ WARNING **ADAPTERS** — Use adapters if using other than 3-inch PVC or CPVC. This is required for different materials (polypropylene or AL29-4C stainless steel) or if using 2-inch pipe.

NOTICE The inside and outside cover plates are stamped to identify the exhaust (vent) and intake (air) openings. Make sure to orient the plates correctly.

1. Locate termination opening and avoid obstructions:
 - a. Use the template supplied with the termination kit.
 - b. Locate the template on the outside building surface where the penetration is to be made.
 - c. Make sure there will be no obstructions that might prevent proper placement of the termination.
 - d. Use the template to mark the locations for the four mounting holes, flue pipe and air pipe. Level the template with a level.

⚠ WARNING For the Weil-McLain plate, the template must be level to ensure the flue and air pipe will be side-to-side, as shown in Figure 34. Failure to comply could result in severe personal injury, death or substantial property damage.

- e. Cut holes in the wall as shown in Figure 34, using the location marks made with the template. For best results, use a small-diameter, long drill bit to drill centering holes for the flue and air pipe openings. Then drill the large openings from both the inside and outside.
 - f. The flue pipe and air pipe may be run through a rectangular cutout (as marked on the template) in lieu of two separate holes if desired.
2. Drill holes for the screws or plastic anchors to secure the outside plate. Install the outside plate and mount the termination on the plate (temporarily).
 - a. Cut the flue pipe so the extension through the wall will cause the vent pipe to fully extend into the termination socket.
 - b. Cut the air pipe so the extension through the wall will butt the air pipe against the stops inside the termination.
 - c. Temporarily slide the flue and air pipes through the opening(s). Slide the inside wall plate over the two pipes and into position on the inside wall.
 - d. Position the inside plate so the flue pipe and air pipe slope downward slightly toward the boiler (1/4" per foot).
 - e. Mark the four (4) mounting holes for the plate.
 - f. Remove the vent and air pipe, drill the four mounting holes, and mount the inside plate.
 3. Test fit the vent/air termination on the vent pipe. Make sure the vent pipe fully penetrates the termination socket and the air pipe butts against the interior stops.
 4. Apply silicon RTV sealant to the interior of the vent termination and slide onto vent pipe. Rotate slightly to spread the silicon to ensure a tight seal around the vent pipe.
 5. Secure the termination in place using the four (4) #10 x 1/2" sheet metal screws and lock washers (see Figure 35).

NOTICE Vent/air pipes and W-M vent/air plate can be oriented in any of the configurations shown in Figure 32, page 32.

Figure 33 Adjacent terminations — OUTSIDE VIEW — clearance from air inlet to exhaust from another appliance

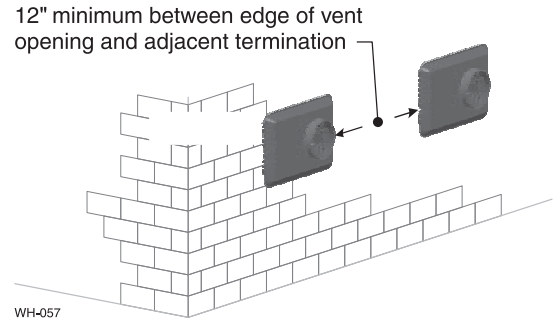
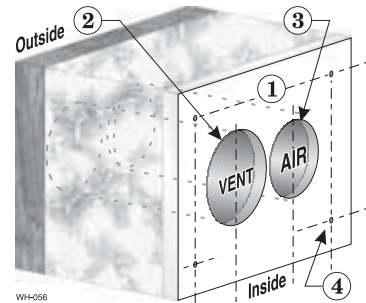
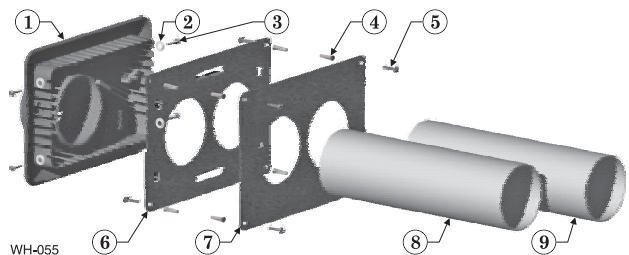

Figure 34 Hole preparation in wall — INSIDE VIEW (use template provided)



- 1 Inside wall
- 2 Drill: 3 1/2" diameter for 3" air pipe; locate using template provided
- 3 For combustible materials, drill: 4" diameter for 3" vent pipe
For noncombustible materials, drill 3 1/2" diameter for 3" vent pipe
Locate opening using template provided
- 4 Drill mounting screw holes using template provided

Figure 35 Termination assembly — INSIDE VIEW Weil-McLain vent/air cap and plates



- | | |
|---------------------------------------|---|
| 1 Vent termination (3") | 6 Outer mounting plate |
| 2 Lock washer, #10 (4) | 7 Inner mounting plate |
| 3 Sheet metal screw, #10 x 1/2" (4) | 8 Vent pipe (butt to screen in termination) |
| 4 Plastic wall anchor (8) | 9 Air pipe (butt to stops in termination) |
| 5 Sheet metal screw, #10 x 1 1/4" (8) | |



DIRECT VENT — Vertical with separate pipes

Allowable vent/air pipe materials & lengths

⚠ WARNING Use only the vent materials and kits listed in Figure 23, page 24. Provide pipe adapters if specified.

1. Locate the terminations such that the total air piping and vent piping from the boiler to the termination will not exceed the maximum length given in Figure 22, page 23.

Polypropylene For polypropylene applications, comply with any additional requirements in the vent system manufacturer's instructions. Provide 3" PVC transition pieces at the boiler vent and air connections. Install a locking collar at every joint.

AL29-4C S.S. For AL29-4C vent pipe applications, comply with any additional requirements in the vent system manufacturer's instructions. Provide a 3" PVC transition piece at the boiler vent connection. The air piping must be PVC or CPVC. Provide a 3" PVC transition piece at the boiler air connection if using 2" air piping.

Determine termination location

1. The air and vent terminations must be installed as shown in Figure 36.
2. The terminations must comply with clearances and limitations shown in Figure 24, page 26.
3. Locate the terminations so they are not likely to be damaged by foreign objects, such as stones or balls, or subject to buildup of leaves or sediment.

Multiple vent/air terminations

1. When terminating multiple boilers, terminate each vent/air connection as described in this manual.

⚠ WARNING Terminate all vent pipes at the same height and all air pipes at the same height to avoid possibility of severe personal injury, death or substantial property damage.

2. Place roof penetrations to obtain minimum clearance of 12 inches between edge of air intake elbow and adjacent vent pipe of another boiler for U. S. installations (see Figure 37, page 35). For Canadian installations, provide clearances required by CSA B149.1 or B149.2 Installation Code and a ULC S636 compliant vent kit.

3. The air inlet of a boiler is part of a direct vent connection. It is not classified as a forced air intake with regard to spacing from adjacent boiler vents.

Figure 36 Separate pipes vertical termination

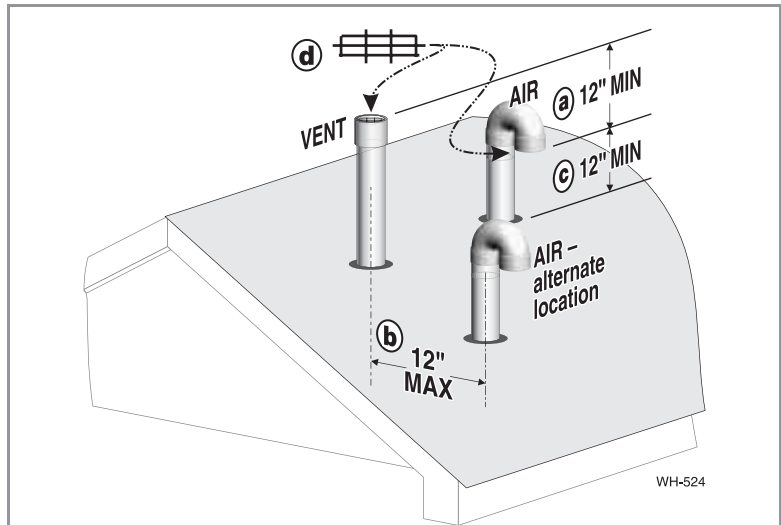

Terminate vent and air pipes such that:

- a **AIR INTAKE IS AT LEAST 12 inches below vent outlet**
- b **AIR INTAKE IS NO FURTHER than 12 inches away center to center**
- c **AIR INTAKE IS AT LEAST 12 inches above roof or snow line**
- d **Vent and air terminations are fitted with bird screens**

Step 1 Read and follow all instructions in this manual. **DO NOT proceed with vent/air installation until you have read page 22 through page 27.** **Polypropylene** **AL29-4C S.S.** See notices at left.

Step 2 Install the boiler in a location that allows proper routing of all vent and air piping to the selected sidewall location.

Step 3 Make sure the selected vertical termination location complies with Figure 24, page 26. (Multiple boiler terminations must also comply with Figure 37, page 35.)

Step 4 Use only the vent materials listed in Figure 23, page 24. Provide pipe adapters where required. Vent piping and air piping lengths must not exceed the values shown in Figure 22, page 23.

Step 5 Prepare the vertical penetrations and secure penetration components as instructed in this section. See "Prepare roof penetrations" on page 35 and "Termination and fittings" on page 35.

Step 6 The air piping must terminate in a 180-degree return bend or **down-turned elbow** as shown above. The vent piping must terminate in a **coupling pointed upward** as shown above.

Step 7 Install vent and air piping between the boiler and the vertical terminations. Slope horizontal piping downward toward the boiler at least 1/4 inch per foot. Install pipe supports every 5 feet on both the horizontal and vertical runs. Install a hanger support within 6 inches of any upturn in the piping. See page 41 for general guidelines. Also comply with vent pipe manufacturer's instructions. **Polypropylene** **AL29-4C S.S.** See notices at left.

Step 8 Insert the vent and air piping through the vertical penetrations and secure the termination fittings.

Step 9 Maintain clearances shown above. Vent and air terminations must be fitted with a bird screen as shown.



⚠ WARNING **USE SWEEP ELBOWS FOR ALL VENT AND AIR PIPING** — DO NOT use short radius elbows for vent or air piping. Boiler performance could be affected.



DIRECT VENT — Vertical with separate pipes *(continued)*

Polypropylene AL29-4C S.S. See notices on previous page.

Prepare roof penetrations

1. Air pipe penetration:
 - a. Cut a hole for the air pipe. Size the air pipe hole as close as desired to the air pipe outside diameter.
2. Vent pipe penetration:
 - a. Cut a hole for the vent pipe. For either combustible or noncombustible construction, size the vent pipe hole at least 0.4" larger than the vent pipe diameter.
 - b. Insert a corrosion resistant metal thimble in the vent pipe hole.
3. Space the air and vent holes no closer than the minimum spacings shown in Figure 26, page 28.
4. Follow all local codes and vent pipe manufacturer's instructions for isolation of vent pipe when passing through floors, ceilings and roofs.
5. Provide flashing and sealing boots sized for the vent pipe and air pipe. Follow all vent pipe manufacturer's instructions.

Termination and fittings

1. Prepare the vent termination elbow and the air termination elbow (Figure 36, page 34) by inserting bird screens. Bird screens must be purchased separately. See the parts list at the end of this manual for part numbers.
2. The air piping must terminate in a down-turned 180-degree return bend as shown in Figure 36, page 34. Locate the air inlet pipe no further than 12 inches from the center of the vent pipe. This placement avoids recirculation of flue products into the combustion air stream.
3. The vent piping must terminate in an up-turned coupling as shown in Figure 36, page 34. The top of the coupling must be at least 12 inches above the air intake. The air inlet pipe and vent pipe can be located in any desired position on the roof, but must always be no further than 12 inches apart (center to center) and with the vent termination at least 12 inches above the air intake.
4. Maintain the required dimensions of the finished termination piping as shown in Figure 36, page 34.
5. Do not extend exposed vent pipe outside of building more than shown in this document. Condensate could freeze and block vent pipe.

Figure 37 Terminations for multiple boilers

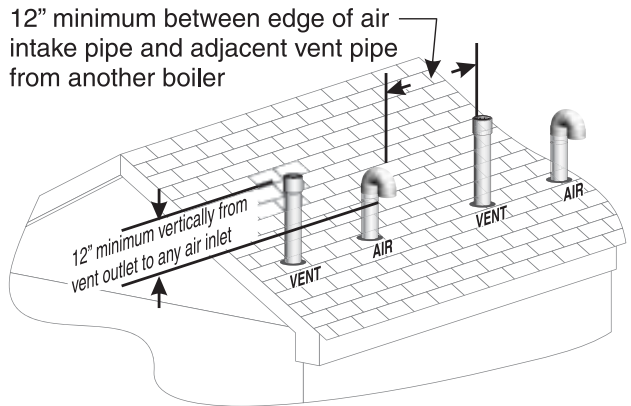

— OR —

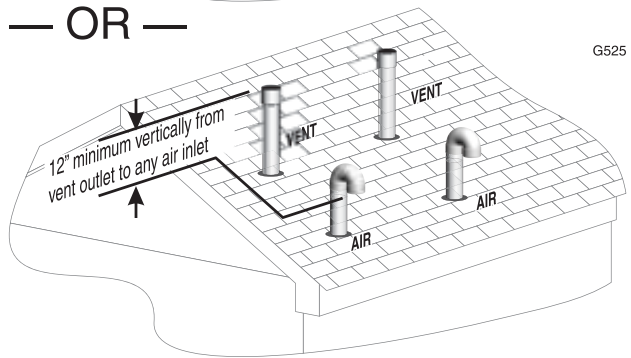

G525



WARNING Also maintain maximum distances between the vent and air pipes for each boiler as shown in Figure 26, page 28.



DIRECT VENT — Vertical concentric

Allowable vent/air pipe materials & lengths

1. The concentric termination kit must be purchased separately.

▲WARNING Use only the vent materials and kits listed in Figure 23, page 24. Provide pipe adapters if specified.

2. Locate the termination such that the total air piping and vent piping from the boiler to the termination will not exceed the maximum length given in Figure 22, page 23.
3. This termination requires a 45-degree elbow that is not supplied with the termination kit. The maximum vent/air pipe lengths include allowance for this elbow.

Polypropylene For polypropylene applications, comply with any additional requirements in the vent system manufacturer's instructions. Provide 3" PVC transitions at the boiler vent and air connections and at the termination if using a 3" PVC concentric vent kit. Install a locking collar at every joint.

AL29-4C S.S. For AL29-4C vent pipe applications, comply with any additional requirements in the vent system manufacturer's instructions. Provide a 3" PVC transition at the boiler vent connection. Air pipe must be PVC or CPVC. Provide a 3" PVC transition at the boiler air connection if using 2" air pipe. Provide transition pieces to PVC at the vent and air pipe termination connections.

Determine termination location

Locate the concentric vent/air termination using the following guidelines:

1. The concentric vent/air assembly must terminate as shown in Figure 40, page 37
2. The termination must comply with the clearances and limitations shown in Figure 24, page 26.
3. Locate the termination so it is not likely to be damaged by foreign objects, such as stones or balls, or subject to buildup of leaves or sediment.
4. For Canadian installations, follow requirements of CSA B149.1 or B149.2 Installation Code and a ULC S636 compliant vent kit.

Multiple vent/air terminations

1. When terminating multiple boilers, install the concentric vent/air termination assemblies as described in this manual.

▲WARNING All vent outlets must terminate at the same height to avoid possibility of severe personal injury, death or substantial property damage.

Figure 38 INSTALLATION SEQUENCE — Concentric vertical

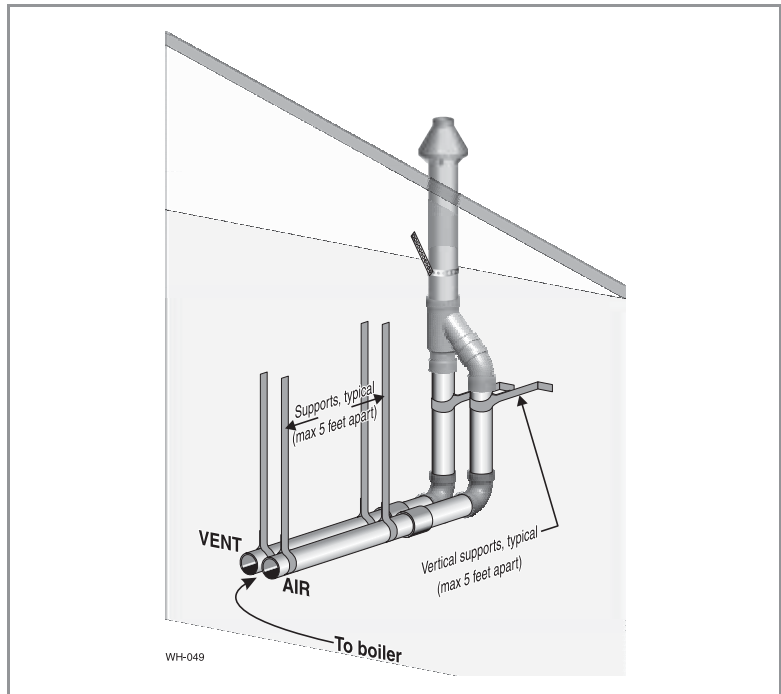

- Step 1** Read and follow all instructions in this manual. **DO NOT proceed with vent/air installation until you have read page 22 through page 27.** **Polypropylene AL29-4C S.S.** See notices at left.
- Step 2** Install the boiler in a location that allows proper routing of all vent and air piping to the selected sidewall location.
- Step 3** Make sure the selected vertical termination location complies with Figure 24, page 26. (Multiple boiler concentric terminations must also comply with Figure 39, page 37.)
- Step 4** Use only the vent materials listed in Figure 23, page 24. Provide pipe adapters where required.
- Step 5** Vent piping and air piping lengths must not exceed the values shown in Figure 22, page 23.
- Step 6** The concentric termination must be assembled and installed before piping from the boiler to the termination.
- Step 7** Prepare the vertical penetration(s) — assemble the concentric termination kit and secure the penetration components as instructed in this section. Provide the supports indicated and mount the termination assembly. See “Prepare roof penetrations” on page 37 and “Mount concentric termination” on page 37. **Polypropylene AL29-4C S.S.** See notices at left.
- Step 8** Install vent and air piping between the boiler and the concentric vent/air termination. Slope horizontal piping downward toward the boiler at least 1/4 inch per foot. See page 41 for general guidelines.
- Step 9** Install pipe supports every 5 feet on both the horizontal and vertical runs. **Polypropylene AL29-4C S.S.** See notices at left.
- Step 10** Install a hanger support within 6 inches of any upturn in the piping. **Polypropylene AL29-4C S.S.** See notices at left.

▲WARNING USE SWEEP ELBOWS FOR ALL VENT AND AIR PIPING — DO NOT use short radius elbows for vent or air piping. Boiler performance could be affected.



DIRECT VENT — Vertical concentric *(continued)*

Polypropylene AL29-4C S.S. See notices on previous page.

2. Place roof penetrations to obtain minimum clearance of 12 inches between the edges of adjacent vent pipes of other boilers for U. S. installations (see Figure 39).
3. For Canadian installations, provide clearances required by CSA B149.1 or B149.2 Installation Code and a ULC S636 compliant vent kit.
4. The air inlet of a boiler is part of a direct vent connection. It is not classified as a forced air intake with regard to spacing from adjacent boiler vents.

Prepare roof penetrations

1. Roof penetration hole:
 - a. Cut a clearance hole to clear the termination outside diameter as prescribed in the kit instructions.
 - b. Insert a corrosion resistant metal thimble in the vent pipe hole.
2. Follow all local codes for isolation of vent pipe when passing through floors, ceilings and roofs.
3. Provide flashing and sealing boots sized for the concentric termination outside diameter.

Mount concentric termination

1. Assemble the vent termination as described for concentric terminations, on page 40.
2. Mount the termination as shown in Figure 40.
3. Support the concentric vent/air termination at the roof penetration as shown in Figure 40 or per concentric kit instructions.
 - The supports/bracing used must support the termination assembly to prevent vertical slippage or sideways movement.
 - The clamps used on the outside of the termination pipe must not cut into the pipe or contain sharp edges that could cause a crack to form.

⚠ WARNING The vent and air piping must be securely supported, and must not rest its weight on the boiler fittings. DO NOT drill or screw into either the vent pipe or air pipe. Failure to properly support the vent and air piping could result in vent piping damage, resulting in possible severe personal injury, death or substantial property damage.

⚠ WARNING When inserting the partially-assembled termination kit through the roof penetration, wrap plastic or other protection over the end of the exposed assembly to prevent debris from entering the pipes. If the air passages become blocked, the boiler will not operate. Once the rain cap has been cemented to the assembly, there is no way to correct the problem. The assembly would have to be replaced if it were cut to be removed and cleaned. Altering the assembly in any way could result in severe personal injury or death due to toxic flue product emissions.

⚠ WARNING If using AL29-4C stainless vent pipe, use the vent pipe manufacturer's PVC adapter if connecting to a PVC concentric vent attachment.

⚠ WARNING Do not connect any other appliance to the vent pipe or multiple boilers to a common vent pipe.

4. After the assembly has been positioned in the roof opening and all supports have been attached, install a bird screen (purchased separately if not included with the kit) and rain cap as follows:
 - a. Place the bird screen on the end of the inner pipe as in Figure 44, page 40, or per kit instructions for polypropylene kits.
 - b. Cement the rain cap in place.

Figure 39 Vertical termination — 3" PVC concentric — single or multiple boilers

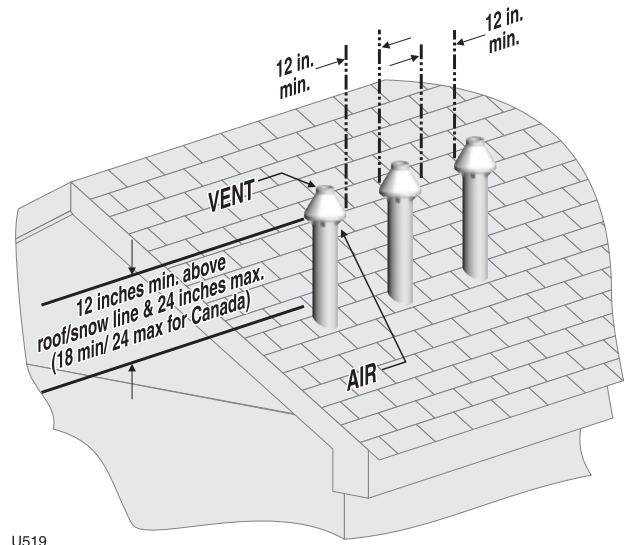

U519

Figure 40 3" PVC concentric termination supports

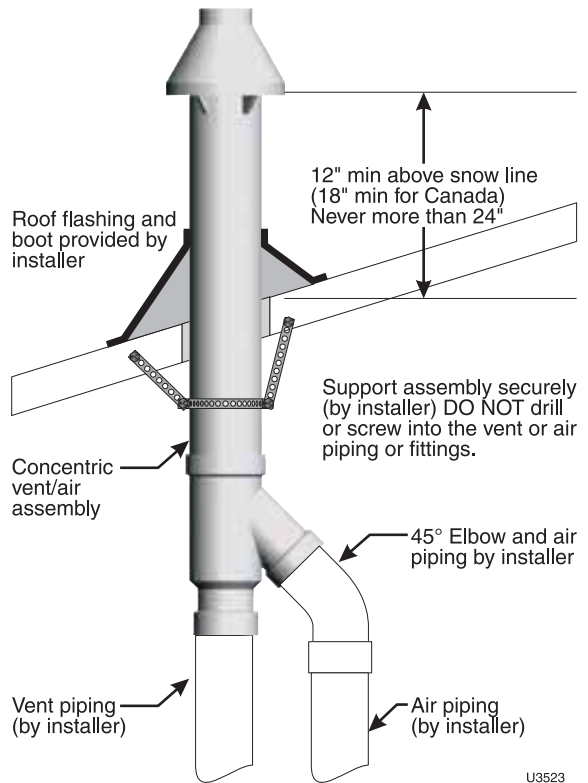

U3523



DIRECT VENT — Vertical vent /sidewall air

Allowable vent/air pipe materials & lengths

▲WARNING Use only the vent materials and kits listed in Figure 23, page 24. Provide pipe adapters if specified.

1. Locate the terminations such that the total air piping and vent piping from the boiler to the termination will not exceed the maximum length given in Figure 22, page 23.

Polypropylene For polypropylene applications, comply with any additional requirements in the vent system manufacturer's instructions. Provide 3" PVC-to-PP transition pieces at the boiler vent and air connections. PP adapter must have smooth, straight section of pipe to insert in to the boiler vent and air connections and must fit and seal tightly. PP adapters with their own seal which would interfere with the internal seal of the boiler vent or air connections must not be used. Refer to page 127 for a list of compliant adapters. Install a locking collar at every joint.

AL29-4C S.S. For AL29-4C vent pipe applications, comply with any additional requirements in the vent system manufacturer's instructions. Provide a 3" PVC transition piece at the boiler vent connection. The air piping must be PVC or CPVC.

2. For 3" to 2" transitions, must use appropriate vent material. For polypropylene or stainless steel must use approved suppliers transitions.

Prepare roof penetration

1. Vent pipe penetration:
 - a. Cut a hole for the vent pipe. For either combustible or noncombustible construction, size the vent pipe hole at least 0.4" larger than the vent pipe diameter.
 - b. Insert a galvanized metal thimble in the vent pipe hole.
2. Follow all local codes for isolation of vent pipe when passing through floors, ceilings and roofs.
3. Provide flashing and sealing boots sized for the vent pipe and air pipe.

Vent termination and fittings

1. Prepare the vent termination coupling by inserting a bird screen. Bird screens must be purchased separately. See the parts list at the end of this manual for part numbers.
2. Maintain the required dimensions of the finished termination piping as shown in Figure 42.

Multiple vent terminations

1. When terminating multiple Evergreen boilers, terminate each vent/air connection as described in this section.
2. Place adjacent terminations at least 6 inches apart.
3. For Canadian installations, provide clearances required by Natural Gas and Propane Installation CAN/CSA B149.1 or B149.2 Installation Code.

Figure 41 INSTALLATION SEQUENCE — Vertical vent/sidewall air

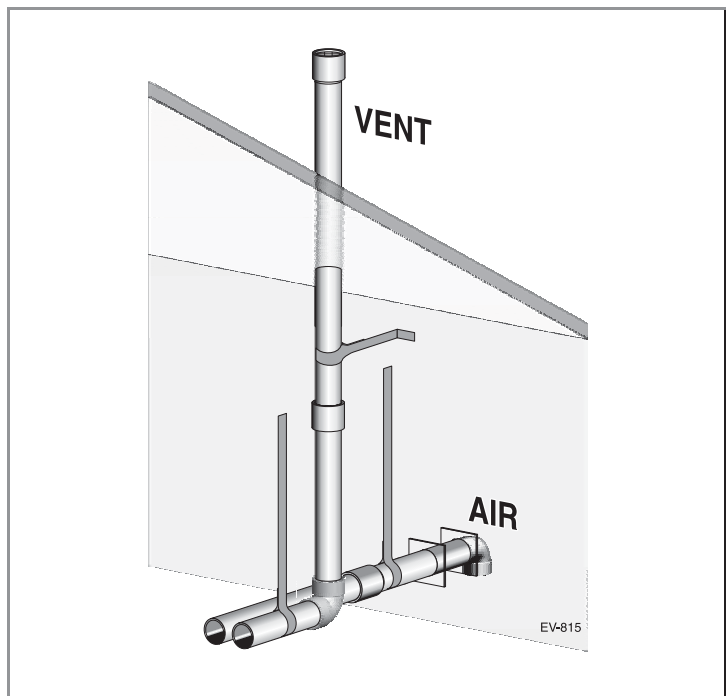

- Step 1** Read and follow all instructions in this manual. **DO NOT proceed with vent/air installation until you have read page 22 through page 27.** **Polypropylene AL29-4C S.S.** See notices at left.
- Step 2** Install the boiler in a location that allows proper routing of all vent and air piping to the selected locations.
- Step 3** Make sure the selected vertical termination location complies with Figure 24, page 26.
- Step 4** Use only the vent materials listed in Figure 23, page 24. Provide pipe adapters where required. Vent piping and air piping lengths must not exceed the values shown in Figure 22, page 23.
- Step 5** Prepare the vertical penetration (vent) and sidewall penetration (air) and secure penetration components as instructed in this section.
- Step 6** The air piping must terminate in a 90-degree **down-turned elbow** as shown above. The vent piping must terminate in a **coupling pointed upward** as shown above.
- Step 7** Install vent and air piping between the boiler and the air and vent terminations. Slope horizontal piping downward toward the boiler at least 1/4 inch per foot. Install pipe supports every 5 feet on both the horizontal and vertical runs. Install a hanger support within 6 inches of any upturn in the piping. See page 39 for general guidelines. Also comply with vent pipe manufacturer's instructions. **Polypropylene AL29-4C S.S.** See notices at left.
- Step 8** Insert the vent and air piping through the penetrations and secure the termination fittings.
- Step 9** Maintain clearances shown in this section. Vent and air terminations must be fitted with bird screens as shown.



▲WARNING

USE SWEEP ELBOWS FOR ALL VENT AND AIR PIPING — DO NOT use short radius elbows for vent or air piping. Boiler performance could be affected.



DIRECT VENT — Vertical vent /sidewall air *(continued)*

Determine location for air inlet elbow

1. The air inlet of an Evergreen boiler is part of a direct vent connection. It is not classified as a forced air intake with regard to spacing from adjacent appliance terminations.
2. Locate the air inlet elbow (termination) using the following guidelines.
3. The air piping must terminate in a down-turned elbow as shown in Figure 43.
 - a. Apply the configuration on the left side of Figure 43 unless the terminations would fail to meet minimum clearance to grade or snow line.
 - b. Apply the configuration on the right side of Figure 43 when the terminations need to be raised higher to meet clearance to grade or snow line.
 - c. The air pipe may run up the side of the building, as shown. The vent and air pipes must be secured with braces, and all clearances and lengths must be maintained. Space braces no further than 24 inches apart.
4. You must consider the surroundings when terminating the air connection:
 - a. Make sure there are no obstructions for air flow. DO NOT locate the termination where plants could grow and cause obstruction to air flow.
 - b. Do not locate the terminations where wind eddies could affect performance or cause recirculation with exhaust from other appliances, such as inside building corners, near adjacent buildings or surfaces, window wells, stairwells, alcoves, courtyards or other recessed areas.
 - c. Locate the air inlet termination at least 12 inches below and 12 inches horizontally from any appliance or building vent outlet.
5. Locate terminations so they are not likely to be damaged by foreign objects, such as stones or balls, or subject to buildup of leaves or sediment.

Multiple air terminations

1. When terminating multiple Evergreen boiler air connections, terminate each air connection as described in this manual.
2. Place wall penetrations to obtain minimum clearances as instructed in this manual.
3. Place adjacent air inlets for multiple Evergreen boilers at least 6 inches apart.
4. For Canadian installations, provide clearances required by Natural Gas and Propane Installation CAN/CSA B149.1 or B149.2 Installation Code.
5. Combustion air (NOT vent piping) can be manifolded as shown in the Evergreen Advanced manual.

Prepare wall penetrations

1. Air pipe penetration:
 - a. Cut a hole for the air pipe. Size the air pipe hole as close as desired to the air pipe outside diameter.
2. Seal exterior openings thoroughly with exterior caulk.

Termination and fittings

1. Prepare the air termination elbow (Figure 43) by inserting a bird screen. Bird screens must be purchased separately. See the parts list at the end of this manual for part numbers.
2. Use metal plates (by installer) at inside and outside penetrations using the method shown in Figure 28, page 29.

NOTICE If extending the air pipe out from the wall, install a coupling on each pipe. Mount the piping with the coupling flush with the outer plate.

Figure 42 Vent termination (through the roof) for direct vent: vertical vent / sidewall air

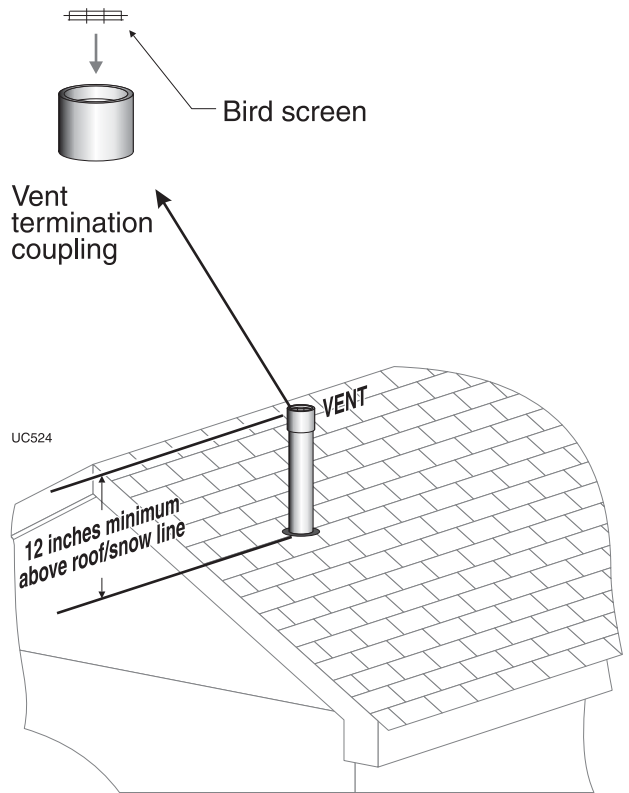
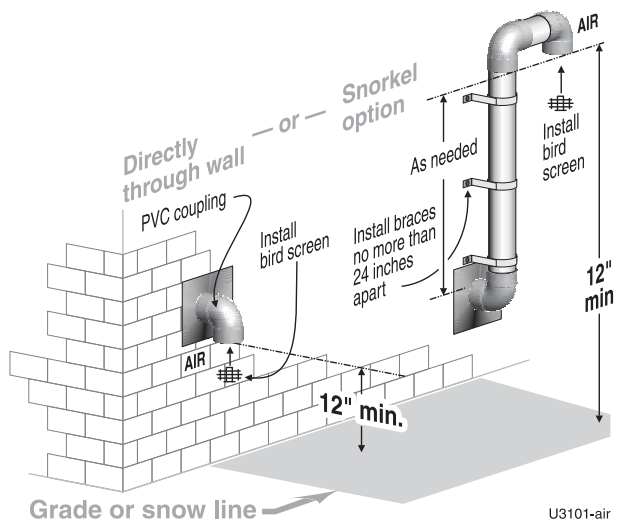

Figure 43 Sidewall air inlet (termination) for direct vent: vertical vent / sidewall air





Concentric termination, typical (sidewall or vertical)

Figure 44 PVC concentric termination assembly — DO NOT attach the rain cap until the termination has been inserted through the roof or wall and all supports have been installed. See LEGEND at right. See kit instructions for details of polypropylene kits.

LEGEND for Figure 44

- 1 — Inner PVC pipe (vent)
- 2 — Outer PVC pipe (air)
- 3 — Rain cap
- 4 — Bird screen
- 5 — Y fitting
- 6 — Finished assembly

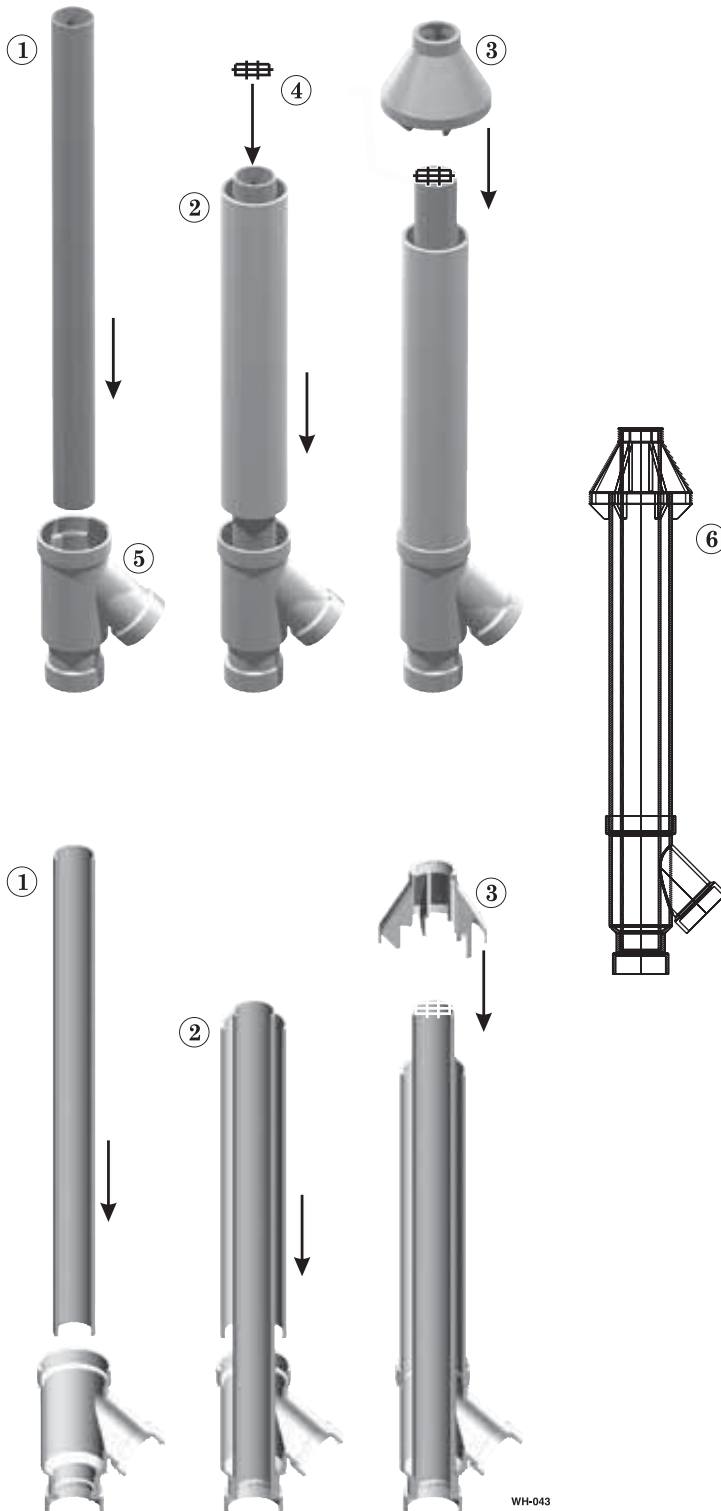

Assembling concentric termination

1. Follow all instructions provided with the concentric termination kit. The following are general guidelines for information only
2. See Figure 44 for the typical assembly of a concentric termination assembly.
3. Prepare the bird screen, item 4 (purchase separately if not included with the kit). Cut the bird screen to size if required. If the bird screen must be trimmed, cut the bird screen to fit the outside diameter of the PVC inner pipe supplied with the termination kit.
4. Partially assemble the vent termination kit in the sequence shown in Figure 44, or per the concentric kit instructions.

WARNING DO NOT install the rain cap and bird screen until the assembly has been inserted through the roof (or sidewall) and all supports have been installed. Follow instructions to cover the end of the assembly with plastic before inserting through the roof penetration to prevent debris from blocking the air passages.

WARNING If necessary, you can shorten the lengths of the inner and outer pipes for a shorter finished assembly. But you must ensure the pipes butt correctly at both ends. Failure to properly assemble the concentric termination can result in flue gas recirculation, causing possible severe personal injury or death.

Polypropylene For polypropylene applications, comply with any additional requirements in the vent system manufacturer's instructions. Provide 3" PVC transitions at the boiler vent and air connections and at the termination if using a PVC concentric vent kit. Install a locking collar at every joint.

AL29-4C S.S. For AL29-4C vent pipe applications, comply with any additional requirements in the vent system manufacturer's instructions. Provide a 3" PVC transition at the boiler vent connection. Air pipe must be PVC or CPVC. Provide a 3" PVC transition at the boiler air connection if using 2" air pipe. Provide transition pieces to PVC at the vent and air pipe termination connections.



Vent and air piping and boiler connections

Follow termination instructions

1. Read and follow all instructions for the termination type used before proceeding with this page. Follow all instructions provided by vent pipe manufacturer.

▲WARNING Use only materials from the manufacturers listed in Figure 23, page 24.

Installing vent and air piping

Polypropylene For polypropylene applications, comply with any additional requirements in the vent system manufacturer's instructions. Provide 3" PVC transition pieces at the boiler vent and air connections, and also at the termination if using the W-M termination plate. Provide 2" or 3" PVC transitions at the termination if using a PVC concentric vent kit. Install a locking collar at every joint.

AL29-4C S.S. For AL29-4C vent pipe applications, comply with any additional requirements in the vent system manufacturer's instructions. Provide a 3" PVC transition piece at the boiler vent connection. Air piping must be PVC or CPVC. Connect to the boiler air piping only with 3" PVC (use a transition piece for 2" air pipe). Provide 3" PVC connections at the termination if using the W-M termination plate. Provide 2" or 3" PVC transitions at the termination if using a PVC concentric vent kit.

1. Work from the boiler to vent or air termination. Do not exceed the lengths given in the previous pages for either the air or vent piping.
2. See Figure 45 for attaching vent (and air) pipes at the boiler. Connections must be 3" PVC or CPVC only — use transitions if needed to adapt to other material or size (2").
3. Cut pipe to required lengths.
4. Dry assemble entire vent or air piping to ensure proper fit before assembling any joint.
5. Maintain minimum clearance of 3/16 inch between vent pipe and any combustible wall or material.
6. Seal wall or floor penetration openings following local code requirements.
7. Assembling PVC or CPVC: (**Polypropylene** **AL29-4C S.S.** — follow pipe manufacturer's instructions for preparation and assembly)
 - a. Deburr inside and outside of pipe ends.
 - b. Chamfer outside of each pipe end to ensure even cement distribution when joining.
 - c. Clean all pipe ends and fittings. Dry thoroughly.
 - d. For each joint:
 - Handle fittings and pipes carefully to prevent contamination of surfaces.
 - Apply primer liberally to both joint surfaces — pipe end and fitting socket.
 - While primer is still damp, lightly apply approved cement to both surfaces in a uniform coating.
 - Apply a second coat to both surfaces. Avoid using too much cement on sockets to prevent cement buildup inside.
 - With cement still wet, insert pipe into fitting, twisting ¼ turn. Make sure pipe is fully inserted.
 - Wipe excess cement from joint. Check joint to be sure a smooth bead of cement shows around the entire joint.

Figure 45 Boiler vent and air connections

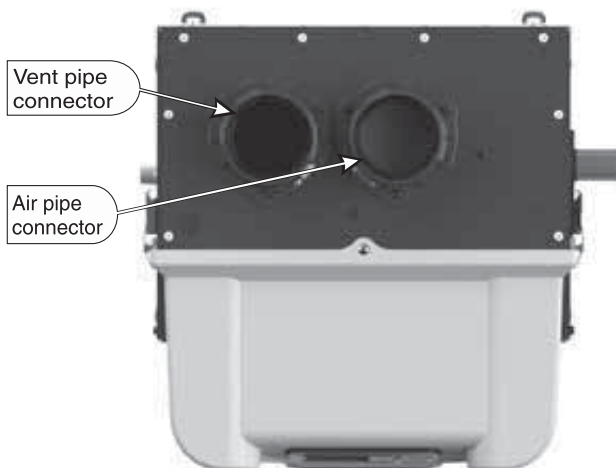

EVG-108

▲WARNING ADAPTERS — Use adapters if using other than 3-inch PVC or CPVC. This is required for different materials or if using 2-inch pipe.

1. Use ONLY 3" PVC or CPVC pipe at boiler connections.
2. Clean and deburr inside and outside of both ends of air and vent pipes. Chamfer boiler end of vent pipe for ease of insertion.

▲WARNING The vent pipe end must be smooth and chamfered to prevent possible damage to sealing gasket in vent pipe adapter.

3. Inspect vent or air adapter (above) — verify no obstructions or foreign objects inside.
4. Loosen clamp screw.
5. Measure 3-½ inches from end of pipe and make a mark with felt-tip pen.
6. Loosen adapter clamp screw.
7. Apply small amount of silicon grease to end of pipe to ease insertion.
8. Insert pipe into adapter.
9. Slide pipe down until the 3½-inch mark is reached.

▲WARNING Do not apply excessive force or bend the adapter or flue/air pipe when inserting. The adapter or seal could be damaged. If any portion of the vent or air system is damaged, it must be replaced.

10. Secure vent or air pipe by tightening the adapter clamp securely. Do not overtighten.
11. The seal is accomplished with the internal gasket. The clamp is only to hold the pipe in place.



▲WARNING USE SWEEP ELBOWS FOR ALL VENT AND AIR PIPING — DO NOT use short radius elbows for vent or air piping. Boiler performance could be affected.



Install water piping

⚠WARNING Use two wrenches when tightening water piping at boiler, using one of the wrenches to prevent the boiler interior piping from turning. Failure to support the boiler piping connections to prevent them from turning could cause damage to boiler components.

General piping information

Use piping unions near boiler

Recommend installing 1" NPT piping unions on boiler outlet and return to facilitate future service requiring heat exchanger removal. Pipe unions are Not included with the boiler.

Additional controls, if required

NOTICE The control uses temperature sensors to provide both high limit protection and modulating temperature control. **The control's high limit function requires manual reset.** Some codes/jurisdictions may require additional external controls for high limit and/or low water cutoff protection.

Additional limit controls

Following standard industry practices, if installation is to comply with ASME or Canadian requirements, an additional high temperature limit may be needed. Consult local requirements for other codes/standards to determine if needed.

1. Install a manual reset high temperature limit constructed to prevent a temperature setting above 200°F in system supply piping between boiler and isolation valve. (Note that the control operating limit function shuts the boiler down at 195°F, or lower if set to a lower value.)

⚠WARNING **Multi-temperature systems** — If the heating system includes circuits that require lower temperature water (radiant slab circuits, for example) as well as higher temperature circuits, it is recommended to protect low-temperature circuits with limit controls that are wired to the control external limit circuit terminals.

⚠WARNING **Low temperature materials** — If using temperature-limited materials (such as PEX tubing) in system piping, it is recommended to protect the system with limit controls that are wired to the controls external limit circuit.

2. See instructions beginning on page 55 for wiring information.
3. If using a manual reset limit control or wiring in the manual reset circuit, set **EVG** control boiler limit at least 20°F less than the external manual reset limit (i.e., set **EVG** control no higher than 180°F for a 200°F external limit, for example).

Separate low water cutoff

1. A separate low water cutoff device is recommended when the boiler is installed above piping level, and may be required by certain state or local codes or insurance companies. Consult local requirements to determine. See the **NOTICE** above regarding the inherent protection provided by the Control module. A low water cut-off is standard equipment with the **Evergreen®** boiler.
2. The Control's integral protection is accepted in many jurisdictions as meeting the requirement for low water protection. See page 60 for details.

3. When required, use a low water cutoff designed for water installations. Electrode probe-type is recommended. See Replacement parts section at the end of this manual for the Weil-McLain low water cut-off kit.
4. Install the low water cut-off (supplied with boiler) in a tee in the supply piping above boiler.
5. See field wiring instructions beginning on page 55 for wiring additional limit controls.

Backflow preventer

Use backflow preventer in the cold water supply piping if required by local codes.

System/zone pipe sizing

(Baseboard, convectors or cast iron radiators ONLY)

For residential space heating applications (other than radiant heating or unit heaters) **ONLY**, you can use the sizing suggestions in Figure 46.

Figure 46 Suggested pipe sizing for system headers and zone piping — **RESIDENTIAL** with baseboard, convectors or cast iron radiators **ONLY** (20°F temperature rise)

EVG Models	System header
70/110	1" or larger
155	1¼" or larger
Recommendations are based on a 20°F temperature drop through the system.	

Suggested maximum load per zone	
Copper pipe and baseboard size	Maximum recommended feet of baseboard
¾"	67
1"	104
Size zone circulators to handle the required flow and head loss for each zone.	

System water piping methods

Direct connection piping to boiler

NOTICE It is recommended, but not required, to use primary/secondary piping to the boiler. Using primary/secondary piping will provide the most efficient and reliable operation of the boiler and the heating system.

Installations using direct connection piping layout should:

1. Read the **NOTICES** and guidelines beginning on page 43 to determine if the system is eligible for this piping strategy.
2. If eligible, reference suggested piping layouts on pages 44 and 45.
3. Use primary/secondary piping if system ineligible.



Direct Connect System Piping - Single Boiler System

Primary/secondary piping to boiler

Using primary/secondary piping will provide the most efficient and reliable operation of the boiler and the heating system.

1. Use information beginning on page 47 to size pump for proper flow through the Evergreen® boiler.
2. Reference suggested piping layouts on pages 47-52.

NOTICE Some installations can be piped in numerous other ways that will work equally as well as the suggestions here.

Verify the application will work:

NOTICE For systems requiring a higher flow than that recommended in Figure 47 – DO NOT use a direct connect piping layout. Design system using a primary/secondary piping layout using guidelines starting on page 47.

NOTICE Systems zoning with circulators must use primary/secondary piping layout using guidelines starting on page 47.

Check system flow rate

To determine whether direct connection will provide suitable flow for the intended application, refer to Figure 47.

4. The minimum temperature drop across the heat exchanger is 20°F. Using flow rates higher than the maximum listed in Figure 47 is NOT RECOMMENDED.
5. Design zoning to ensure minimum flow rate is maintained under any call for heat condition that could see full input rate (High Fire).

NOTICE Systems using a modulating pump may operate below the minimum flow rates listed in Figure 47 only if the boiler is operating at a reduced firing rate (low fire) when doing so. A pump that modulates based on the system Delta T (ΔT) would provide such operation assurance by varying flow with firing rate.

Use a primary/secondary piping layout if the total flow through the heat exchanger will be higher than the maximum listed in Figure 47.

Check system pipe design

Only systems with a single system pump zoned with zone valves may use the direct connect system piping methods shown here.

NOTICE Any system zoned with zone valves must include a by-pass pressure regulator. Failure to comply may reduce pump life.

Circulators

The boiler circulator (Taco 007e for Evergreen® 70 and 110; Taco 0015e for Evergreen® 155) is shipped loose. Locate it in the boiler outlet, as shown in the appropriate piping diagram in this manual.

WARNING DO NOT use the boiler circulator in any location other than the ones shown in this manual. The boiler circulator is selected to ensure adequate flow through the boiler.

Failure to comply could result in unreliable performance and nuisance shut downs from insufficient flow.

NOTICE If replacing included circulator with replacement Taco 00e model, replace only with Taco Model VR1816 circulator. Set VR1816 to match boiler size below:

- EVG 70: Constant Pressure 10
- EVG 110: Constant Pressure 10
- EVG 155: Max

You may use standard Taco 007 and 0015 circulators in place of respective 007e and 0015e models.

Expansion tank location

Figure 48 and Figure 50 show typical installation of the system expansion tank. It is highly recommended that you locate the air separator and expansion tank as shown in the suggested piping drawings on page 44 and page 45.

Ensure that the expansion tank size will handle boiler and system water volume and temperature. See tank manufacturer's instructions and ratings for details. Additional tanks may be added to the system if needed to handle the expansion. These tanks may be installed by connecting to tees in the system piping.

CAUTION Undersized expansion tanks cause system water to be lost from the relief valve and makeup water to be added through the fill valve. Eventual boiler failure can result due to excessive make-up water addition. Always locate the cold-water fill connection at the expansion tank. Never locate this elsewhere.

Diaphragm- or bladder-type tank:

Refer to Figure 48 for suggested piping when using a diaphragm- or bladder-type expansion tank.

Install an automatic air vent on top of the air separator, per separator manufacturer's instructions.

NOTICE Diaphragm- or bladder-type expansion tank—Control fill pressure with the tank air charge pressure. Always check pressure and charge tank with tank removed from system to be sure reading is accurate. Boiler relief valve is set for 30 PSIG. Operating pressure of system, after temperature expansion above cold fill pressure, should not exceed 24 PSIG to avoid weeping of relief valve.

Figure 47 Maximum and minimum flow rates through boiler heat exchanger

EVG Model	MAXIMUM flow rate through boiler	MINIMUM flow rate through boiler
70	6.5 GPM	3.0 GPM
110	10.0 GPM	5.0 GPM
155	14.5 GPM	7.0 GPM



Direct Connect System Piping - Single Boiler System *(continued)*

Figure 48 Piping to diaphragm- (or bladder-) type expansion tank

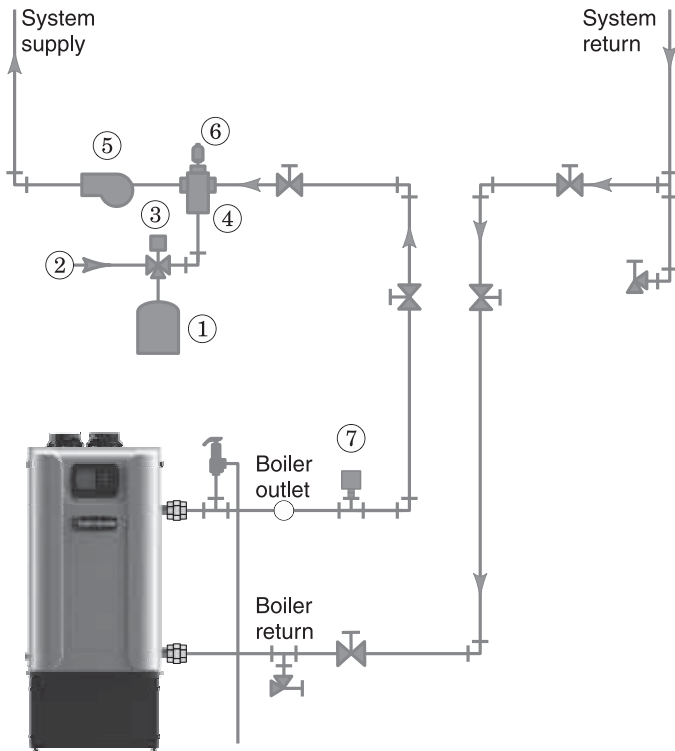

- ① Diaphragm-type expansion tank
- ② Make-up water supply
- ③ Fill valve, typical
- ④ Air separator
- ⑤ System circulator
- ⑥ Automatic air vent
- ⑦ Low Water Cut-Off

EVG-040

Closed-type expansion tank:

CAUTION DO NOT use a closed-type tank if connecting to a water heater that is equipped with an automatic air vent.

Figure 50 shows suggested piping when using a closed-type expansion tank, in which the air is directly in contact with tank water.

Connect piping (1/2" or 3/4") from the air separator outlet to the tank fitting. Slope any horizontal piping a minimum of 1 inch per 5 feet of horizontal pipe.

Always use a tank fitting such as the B&G Tank-trol or Taco Taco-trol (shown). The fitting reduces gravity flow of water in the piping to the tank, avoids air bubbling through the tank water, and provides the proper fill height in the tank

CAUTION Correct all leaks in the system or tank piping. Leaks allow air to escape from the system and will cause water-logging of the tank. This will result in water loss through the boiler relief valve due to over-pressurization. **NEVER** use an automatic air vent in a system equipped with a closed-type expansion tank. The air removed from the system will cause water-logging of the expansion tank.

NOTICE Closed-type expansion tank—Follow tank manufacturer's instructions for filling the tank. Typical tank sizing provides for approximately 12 PSIG when the tank is filled to the normal level and system water is cold. Note that boiler relief valve is set for 30 PSIG. Operation pressure of system, after temperature expansion above cold fill pressure, should not exceed 24 PSIG to avoid weeping of relieve valve.

Figure 49 Pressure drop through EVG heat exchanger (graph and table)

EVG 70 or 110		EVG 155	
Flow Rate (GPM)	Head Loss (ft. w.c.)	Flow Rate (GPM)	Head Loss (ft. w.c.)
3.0	0.11	7.0	0.39
5.0	0.30	9.0	0.65
6.5	0.51	11.0	0.97
8.0	0.77	13.0	1.35
10.0	1.20	14.5	1.68

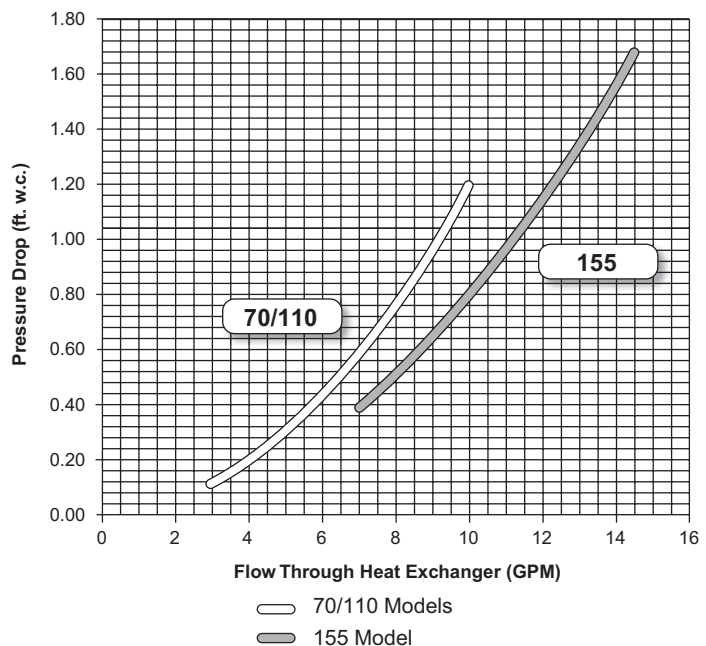



Direct Connect System Piping - Single Boiler System *(continued)*

Figure 50 Piping to closed-type expansion tank

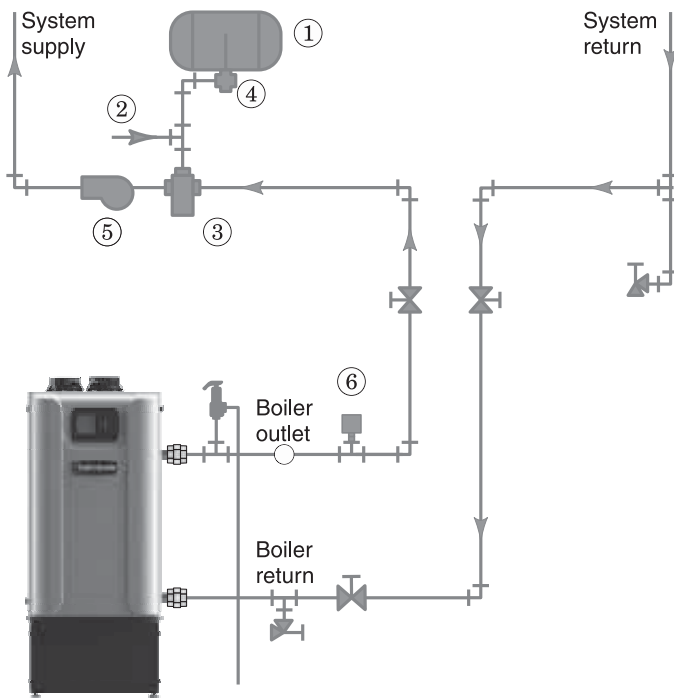

- ① Closed-type expansion tank
- ② Make-up water supply
- ③ Air separator
- ④ Tank fitting
- ⑤ System circulator
- ⑥ Low Water Cut-Off

EVG-041

System water piping methods

Head loss through boiler piping

See Figure 49 for the head loss through the boiler.

Use boiler head loss values to size pump after determining other piping head loss values.

System circulator

1. Install a system circulator as shown in the piping diagram in the Direct Connect System Piping section on page 47.
2. If provided circulator does not meet flow requirement, circulator must be supplied by the installer.

System circulator flow rates

1. Size circulators based on the flow rate required to achieve the temperature rise or drop.
2. You can closely estimate the required flow through a circuit by using the following formula, where TD is temperature rise (or drop), FLOW is flow rate (in gpm), and BTUH is the heat load for the circuit:

$$\text{FLOW} = \frac{\text{BTUH}}{\text{TD} \times 500}$$

Examples:

Consider a system loop for a system with total heating input equal to 210,000 Btuh. The desired temperature drop through the system piping is 20°F. Then the required flow rate is:

$$\text{FLOW} = \frac{210,000}{20 \times 500} = 21 \text{ gpm}$$

SIMPLIFIED:

For 20° temperature drop, FLOW = MBH / 10.

System circulator head requirement

1. The circulator must be capable of delivering the required flow against the head loss that will occur in the boiler piping.
2. Determine the pipe size needed and the resultant head loss using accepted engineering methods.

Install relief valve

1. Install relief valve in 1" x 1" x 3/4" (for 70/110) or 1 1/4" x 1 1/4" x 3/4" (for 155) reducing tee piped from boiler supply (Figure 8, page 14).
2. Pipe the relief valve only as shown, in the location shown.
3. Connect discharge piping to safe disposal location, following guidelines in the WARNING below.

WARNING

To avoid water damage or scalding due to relief valve operation, as per local or state codes:

Install relief valve ONLY with the spindle vertical, as shown in illustrations in this manual.

Discharge line must be connected to relief valve outlet and run to a safe place of disposal. Terminate the discharge line in a manner that will prevent possibility of severe burns or property damage should the valve discharge. Locate away from the top of the boiler.

Discharge line must be as short as possible and be the same size as the valve discharge connection throughout its entire length.

Discharge line must pitch downward from the valve and terminate at least 6" above the floor drain where any discharge will be clearly visible.

The discharge line shall terminate plain, not threaded, with a material serviceable for temperatures of 375 °F or greater.

Do not pipe the discharge to any place where freezing could occur.

No shutoff valve shall be installed between the relief valve and boiler, or in the discharge line. Do not plug or place any obstruction in the discharge line.

Test the operation of the valve after filling and pressurizing system by lifting the lever. Make sure the valve discharges freely. If the valve fails to operate correctly, replace it with a new relief valve.

Failure to comply with the above guidelines could result in failure of the relief valve to operate, resulting in possibility of severe personal injury, death or substantial property damage.



Direct Connect System Piping - Single Boiler System *(continued)*

ZONE VALVE zoning – direct connection (Shown with optional DHW piping)

See Figure 51.

1. This configuration is for zone valve systems that qualify to use direct connection piping based on the criteria on page 43 only. If system does not qualify, pipe using primary/secondary piping. See pages 48-52 for piping suggestions and guidelines.
2. Systems zoned with zone valves **MUST** use a by-pass pressure regulator (Taco 3196 shown).
3. Install a system circulator (supplied by installer) capable of delivering the proper flow and head as shown.

Expansion Tank required

1. Provide a system expansion tank following the guidelines on page 43 or page 45.
2. **DO NOT** use a closed-type tank if connecting to a water heater that is equipped with an automatic vent.

Domestic Hot Water (DHW) tank, if used

1. DHW direct connection—Pipe from the near-boiler piping to the DHW tank's boiler connections as shown.
2. DHW as zone— A DHW tank can be connected as a zone if a DHW tank is **NOT** already connected to the boiler. See notices on page 139 to ensure compliance with the 2007 Energy Act. See Advanced Manual to configure Boiler Pump to run during DHW demands and change TARGET MOD SENSOR to System Supply.
3. DHW Priority operation— Using Priority 1 for DHW (default) will turn off lower priorities during DHW calls. The MAX ON TIME setting can be adjusted to limit how long this occurs. Use Priority 2 or 3 for DHW if DHW priority is not desired.

NOTICE Overriding the Outdoor Reset function by setting control to DHW mode when system is intended for space heating may violate **Section 303 of the 2007 Energy Act**. See page 139 for compliance information and exemptions.

Controlling the circulators

1. The control can control up to four circulators (boiler circulator and three others). Refer to Field wiring, beginning on page 55, for instructions on wiring to circulators.
2. The factory default settings are: all three inputs are set up for Space Heating (Priority 2). Each input correlates to its respective circulator output. For DHW Priority applications, wire aquastat to Input 1 and assign to Priority 1. See Field wiring instructions, beginning on page 55, for details.

Figure 51 EVG 70/110/155 Zone valve zoning direct connection (system circulator provides flow for system)

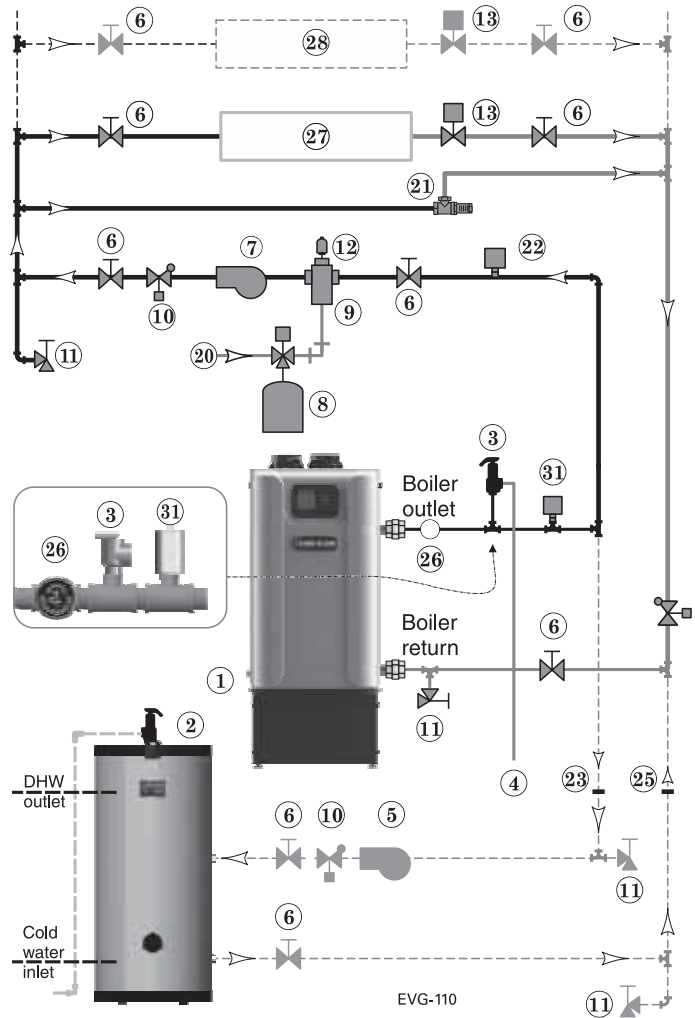

3. For more than 3-zones, use Weil-McLain WMZV zone valve controller.

NOTICE Connect zone valve end switches to Priority 2 input. Connect system circulator to Circ. 2 output.

CAUTION Use isolation relays if connecting 3-wire zone valve end switches to the input.

LEGEND for Figures 51,

Note: This is a common legend for all piping diagrams. Not all items listed appear in every figure.

1 Evergreen® boiler	13 Zone valves	22 High limit temperature control
2 Indirect Water Heater, if used	14 Primary/secondary connection (tees no more than 12 inches apart)	23 DHW tank boiler water supply connection, when used
3 Relief valve, supplied with boiler, field piped — MUST be piped to boiler supply connection — see page 14 for information	15 Expansion tank, closed type, if used (some chiller systems may use a diaphragm-type expansion tank)	24 Zone circulator
4 Relief valve piping to drain — see page 45	16 Water chiller	25 DHW tank boiler water return connection, when used
5 DHW circulator	17 Check valve	26 Pressure/temperature gauge, supplied with boiler, field piped
6 Isolation valves	18 Y-strainer	27 Heating circuits
7 System circulator	19 Balancing valve	28 Additional heating circuits, if any
8 Expansion tank, diaphragm type, if used	20 Make-up water supply – Use applicable codes to determine if backflow preventers, pressure reducing valves, and fill valves may be required	29 Boiler circulator, if any
9 Air separator	21 By-pass pressure regulator, REQUIRED for zone valve systems unless other provision is made	30 Mixing valve, if any
10 Flow/check valves		31 Low Water Cut-Off
11 Purge/drain valves (one drain valve shipped loose with boiler)		
12 Auto air vent		



Primary/Secondary System Piping - Single Boiler System

See Advanced Manual for Multiple Boiler Systems

Expansion tank location

Figure 52 and Figure 53 show typical installation of the system expansion tank. It is highly recommended that you locate the air separator and expansion tank as shown in the suggested piping drawings on pages 50-52.

Ensure that the expansion tank size will handle boiler and system water volume and temperature. See tank manufacturer's instructions and ratings for details. Additional tanks may be added to the system if needed to handle the expansion. These tanks may be installed by connecting to tees in the system piping.

CAUTION Undersized expansion tanks cause system water to be lost from the relief valve and makeup water to be added through the fill valve. Eventual boiler failure can result due to excessive make-up water addition. Always locate the **cold-water fill connection** at the expansion tank. Never locate this elsewhere.

Diaphragm- or bladder-type tank:

Refer to Figure 52 for suggested piping when using a diaphragm- or bladder-type expansion tank.

NOTICE Diaphragm- or bladder-type expansion tank—Control fill pressure with the tank air charge pressure. Always check pressure and charge tank with tank removed from system to be sure reading is accurate. Boiler relief valve is set for 30 PSIG. Operating pressure of system, after temperature expansion above cold fill pressure, should not exceed 24 PSIG to avoid weeping of relief valve.

Install an automatic air vent on top of the air separator, per separator manufacturer's instructions.

Figure 52 Piping to diaphragm (or bladder) expansion tank

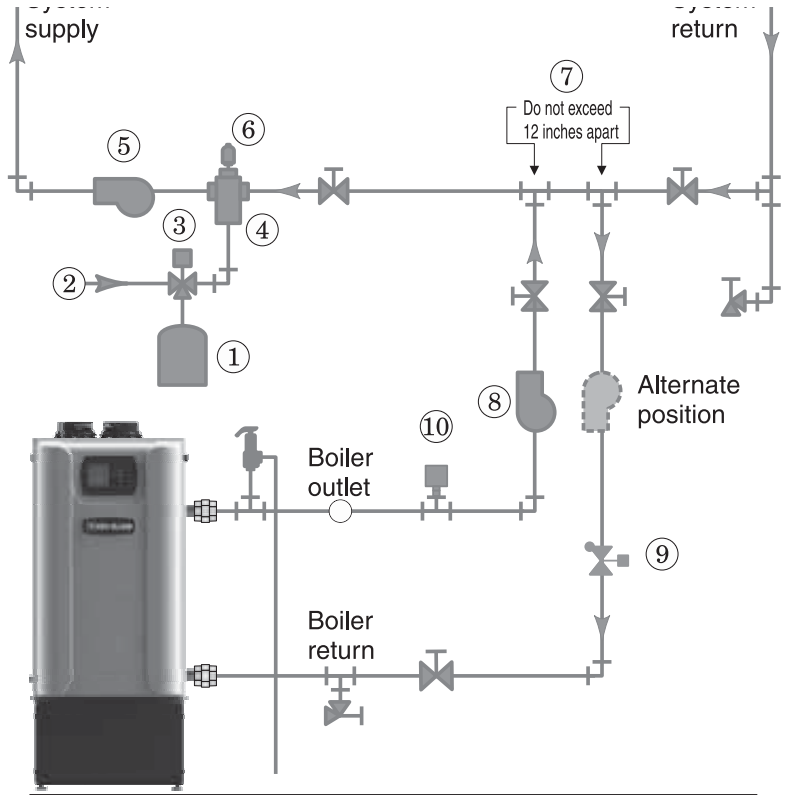

- ① Diaphragm-type expansion tank
- ② Make-up water supply
- ③ Fill valve, typical
- ④ Air separator
- ⑤ System circulator
- ⑥ Automatic air vent
- ⑦ Primary/secondary connection
- ⑧ Boiler circulator
- ⑨ Flow/check valve
- ⑩ Low Water Cut-Off

EVG-040a

Closed-type expansion tank

CAUTION DO NOT use a closed-type tank if connecting to a water heater that is equipped with an automatic air vent.

Figure 53, page 48 shows suggested piping when using a closed-type expansion tank, in which the air is directly in contact with tank water.

Connect piping (1/2" or 3/4") from the air separator outlet to the tank fitting. Slope any horizontal piping a minimum of 1 inch per 5 feet of horizontal pipe.

Always use a tank fitting such as the B&G Tank-trol or Taco Taco-trol (shown). The fitting reduces gravity flow of water in the piping to the tank, avoids air bubbling through the tank water, and provides the proper fill height in the tank. Continued on next page.



Primary/Secondary System Piping - Single Boiler System *(continued)*

See Advanced Manual for Multiple Boiler Systems

CAUTION Correct all leaks in the system or tank piping. Leaks allow air to escape from the system and will cause water-logging of the tank. This will result in water loss through the boiler relief valve due to over-pressurization. **NEVER** use an automatic air vent in a system equipped with a closed-type expansion tank. The air removed from the system will cause water-logging of the expansion tank.

NOTICE Closed-type expansion tank—Follow tank manufacturer’s instructions for filling the tank. Typical tank sizing provides for approximately 12 PSIG when the tank is filled to the normal level and system water is cold. Note that boiler relief valve is set for 30 PSIG. Operation pressure of system, after temperature expansion above cold fill pressure, should not exceed 24 PSIG to avoid weeping of relieve valve.

Figure 53 Piping to closed-type expansion tank

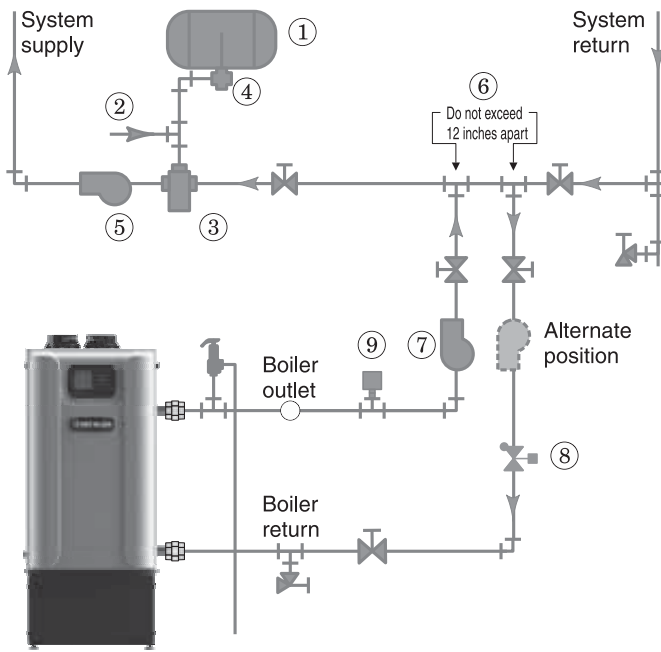

- ① Closed-type expansion tank
- ② Make-up water supply
- ③ Air separator
- ④ Tank fitting
- ⑤ System circulator
- ⑥ Primary/secondary connection
- ⑦ Boiler circulator
- ⑧ Flow/check valve
- ⑨ Low Water Cut-Off

EVG-041a

System water piping methods

Near boiler piping

1. Connect boiler to system only as shown in Figure 52, page 47 and Figure 53. The primary/secondary piping shown ensures the boiler loop will have sufficient flow.
2. Select a boiler loop temperature rise from Figure 54. The table indicates the flow and head loss characteristics at that temperature rise.

NOTICE Verify that the boiler loop piping matches closely with the listed criteria in the *NOTICE* below.

If near boiler piping is different, calculate head loss separately using heat exchanger pressure drop information from Figure 49, page 44 and match to an the included circulator.

NOTICE The pressure drops shown are for near boiler piping as illustrated in Figure 52, page 47 and Figure 53 with 20 feet of straight piping.

Figure 54 Estimated head loss of boiler loop piping and recommended circulators.

ΔT (°F)	Flow (GPM)	HEAD (ft. w.c.)
Model 70 (70,000 Btu/hr)		
20	6.5	3.6
30	4.3	2.0
40	3.3	1.3
Model 110 (110,000 Btu/hr)		
20	10.1	7.1
30	6.7	3.8
40	5.1	2.5
Model 155 (155,000 Btu/hr)		
20	14.3	6.1
30	9.5	2.7
40	7.2	1.5

Figure 55 Estimated head loss of boiler loop piping and recommended circulators.

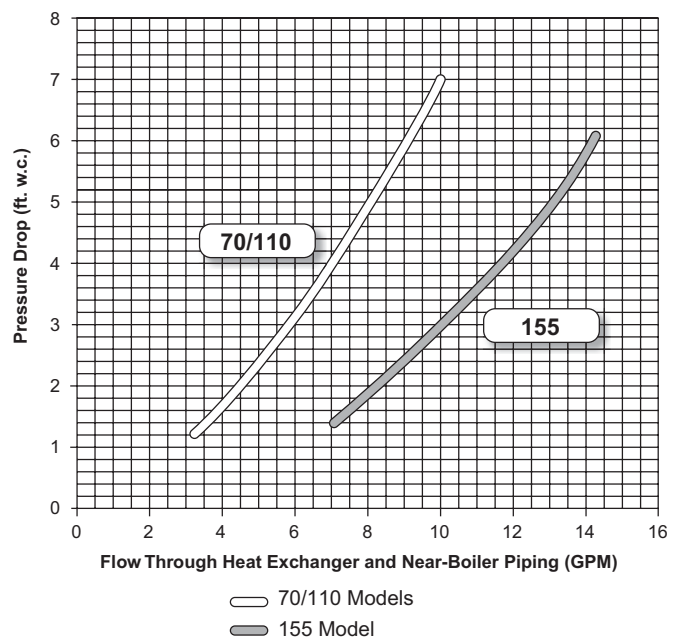



Primary/Secondary System Piping - Single Boiler System *(continued)*

See Advanced Manual for Multiple Boiler Systems

System circulators and zone circulators

1. Install a system circulator or zone circulators as shown in the piping diagrams in the Primary/Secondary System Piping section in this manual. These circulators must be supplied by the installer.

System or zone circulators flow rates

1. Size circulators based on the flow rate required to achieve the temperature change you needed. You can closely estimate temperature rise (or drop) through a circuit by using the following formula, where TD is temperature rise (or drop), FLOW is flow rate (in gpm), and BTUH is the heat load for the circuit:

$$\text{FLOW} = \frac{\text{BTUH}}{\text{TD} \times 500}$$

Examples:

1. Consider a system loop for a system with total heating load equal to 210,000 Btuh. The desired temperature drop through the system piping is 20°F. Then the required flow rate is:

$$\text{FLOW} = \frac{210,000}{20 \times 500} = 21 \text{ gpm}$$

SIMPLIFIED:

For 20° temperature drop, FLOW = MBH / 10.

System or zone circulator head requirement

1. The circulator must be capable of delivering the required flow against the head loss that will occur in the piping.
2. Determine the pipe size needed and the resultant head loss using accepted engineering methods.

Install relief valve

1. Install relief valve in 1 " x 1 " x ¾" (for 70/110) or 1 ¼" x 1 ¼" x ¾" (for 155) reducing tee piped from boiler supply piping tee (Figure 8, page 14).
2. Pipe the relief valve only as shown, in the location shown.
3. Connect discharge piping to safe disposal location, following guidelines in the **WARNING** below.



To avoid water damage or scalding due to relief valve operation, as per local or state codes:

Install relief valve ONLY with the spindle vertical, as shown in illustrations in this manual.

Discharge line must be connected to relief valve outlet and run to a safe place of disposal. Terminate the discharge line in a manner that will prevent possibility of severe burns or property damage should the valve discharge. Locate away from the top of the boiler.

Discharge line must be as short as possible and be the same size as the valve discharge connection throughout its entire length.

Discharge line must pitch downward from the valve and terminate at least 6" above the floor drain where any discharge will be clearly visible.

The discharge line shall terminate plain, not threaded, with a material serviceable for temperatures of 375°F or greater.

Do not pipe the discharge to any place where freezing could occur.

No shutoff valve shall be installed between the relief valve and boiler, or in the discharge line. Do not plug or place any obstruction in the discharge line.

Test the operation of the valve after filling and pressurizing system by lifting the lever. Make sure the valve discharges freely. If the valve fails to operate correctly, replace it with a new relief valve.

Failure to comply with the above guidelines could result in failure of the relief valve to operate, resulting in possibility of severe personal injury, death or substantial property damage.



Primary/Secondary System Piping - Single Boiler System *(continued)*

See Advanced Manual for Multiple Boiler Systems

ZONE VALVE zoning – primary/secondary

(Shown with optional DHW piping)

See Figure 56.

1. This configuration is for zone valve systems using a boiler loop connected as a secondary circuit off of a primary system loop. Systems whose flow characteristics do not comply with those listed in Direct Connect System Piping must pipe the boiler loop as a secondary circuit as show.
2. Systems zoned with zone valves **MUST** use a by-pass pressure regulator.
3. Install a system circulator (supplied by installer) capable of delivering the proper flow and head as shown.

Expansion Tank required

1. Provide a system expansion tank following the guidelines on page 47 or 48.
2. **DO NOT** use a closed-type tank if connecting to a water heater that is equipped with an automatic vent.

Domestic Hot Water (DHW) tank, if used

1. DHW direct connection—Pipe from the near-boiler piping to the DHW tank's boiler connections as shown.
2. DHW as zone— A DHW tank can be connected as a zone if a DHW tank is **NOT** already connected to the boiler. See notices on page 139 to ensure compliance with the 2007 Energy Act. See Advanced Manual to configure Boiler Pump to run during DHW demands and change TARGET MOD SENSOR to System Supply.
3. DHW Priority operation— Using Priority 1 for DHW (default) will turn off lower priorities during DHW calls. The MAX ON TIME setting can be adjusted to limit how long this occurs. Use Priority 2 or 3 for DHW if DHW priority is not desired.

NOTICE Overriding the Outdoor Reset function by setting control to DHW mode when system is intended for space heating may violate **Section 303 of the 2007 Energy Act**. See page 139 for compliance information and exemptions.

Controlling the circulators

1. The control can control up to four circulators (boiler circulator and three others). Refer to Field wiring, beginning on page 55, for instructions on wiring to circulators.
2. The factory default settings are: all three inputs are set up for Space Heating (Priority 2). Each input correlates to its respective circulator output. For DHW Priority applications, wire aquastat to Input 1 and assign to Priority 1. See Field wiring instructions, beginning on page 55, for details.

Figure 56 Zone valve zoning — primary/secondary connection — a system circulator is required

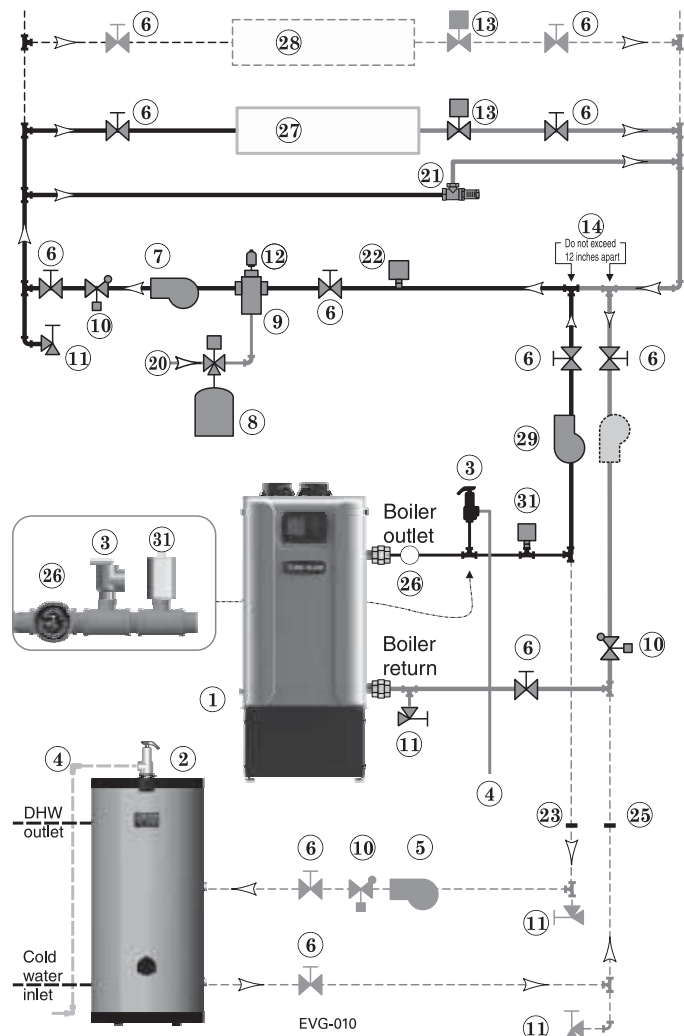

3. For more than 3-zones, use Weil-McLain WMZV zone valve controller.

NOTICE Connect zone valve end switches to Priority 2 input. Connect system circulator to Circ. 2 output.

CAUTION Use isolation relays if connecting 3-wire zone valve end switches to the input.

LEGEND for Figure 56.		Note: This is a common legend for all piping diagrams. Not all items listed appear in every figure.
1 Evergreen® boiler	12 Auto air vent	21 By-pass pressure regulator, REQUIRED for zone valve systems unless other provision is made 22High limit temperature control (If used)
2 Indirect Water Heater, if used	13 Zone valves	23 DHW tank boiler water supply connection, when used
3 Relief valve, supplied with boiler, field piped — MUST be piped to boiler supply connection — see page 14 for information	14 Primary/secondary connection (tees no more than 12 inches apart)	24 Zone circulator
4 Relief valve piping to drain — see page 49	15 Expansion tank, closed type, if used (some chiller systems may use a diaphragm-type expansion tank)	25 DHW tank boiler water return connection, when used
5 DHW circulator	16 Water chiller	26 Pressure/temperature gauge, supplied with boiler, field piped
6 Isolation valves	17 Check valve	27 Heating circuits
7 System circulator	18 Y-strainer	28 Additional heating circuits, if any
8 Expansion tank, diaphragm type, if used	19 Balancing valve	29 Boiler circulator, if any
9 Air separator	20 Make-up water supply – Use applicable codes to determine if backflow preventers, pressure reducing valves, and fill valves may be required	30 Mixing valve, if any
10 Flow/check valves		31 Low Water Cut-Off
11 Purge/drain valves (one drain valve shipped loose with boiler)		



Primary/Secondary System piping *(continued)*

Circulator zoning – primary/secondary (Shown with optional DHW piping)

See Figure 57.

1. This configuration is for circulator-zoned systems using a boiler loop connected as a secondary circuit off of a primary system loop. Systems zoned with circulators must pipe the boiler loop as a secondary circuit as show.
2. Install a separate circulator (supplied by installer) for each zone capable of delivering the proper flow and head as shown.

Expansion Tank required

1. Provide a system expansion tank following the guidelines on page 47 or 48.
2. **DO NOT** use a closed-type tank if connecting to a water heater that is equipped with an automatic vent.

Domestic Hot Water (DHW) tank, if used

1. DHW direct connection—Pipe from the near-boiler piping to the DHW tank's boiler connections as shown.
2. DHW as zone—A DHW tank can be connected as a zone if a DHW tank is **NOT** already connected to the boiler. See notices on page 139 to ensure compliance with the 2007 Energy Act. See Advanced Manual to configure Boiler Pump to run during DHW demands and change TARGET MOD SENSOR to System Supply.
3. DHW Priority operation— Using Priority 1 for DHW (default) will turn off lower priorities during DHW calls. The MAX ON TIME setting can be adjusted to limit how long this occurs. Use Priority 2 or 3 for DHW if DHW priority is not desired.

NOTICE Overriding the Outdoor Reset function by setting control to DHW mode when system is intended for space heating may violate **Section 303 of the 2007 Energy Act**. See page 139 for compliance information and exemptions.

Controlling the circulators

1. The control can control up to four circulators (boiler circulator and three others). Refer to Field wiring, beginning on page 55, for instructions on wiring to circulators.
2. The factory default settings are: all three inputs are set up for Space Heating (Priority 2). Each input correlates to its respective circulator output. For DHW Priority applications, wire aquastat to Input 1 and assign to Priority 1. See Field wiring instructions, beginning on page 55, for details.

Figure 57 Circulator zoning plus optional DHW piping

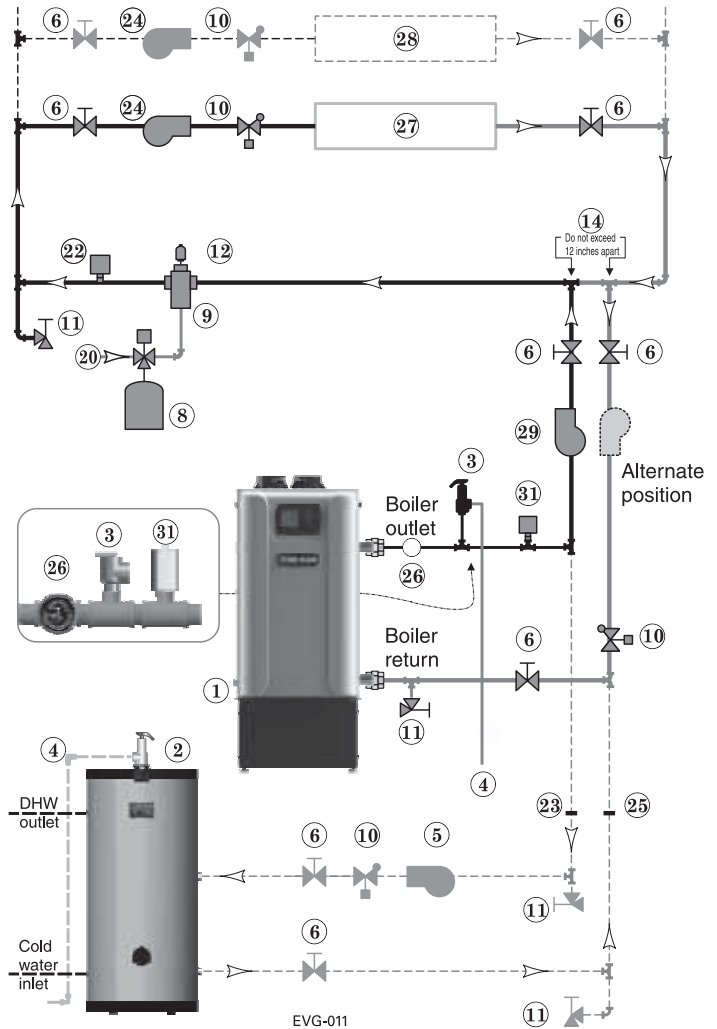

3. For more than 3-zones, use Weil-McLain WMZV zone valve controller.

NOTICE Connect zone valve end switches to Priority 2 input. Connect system circulator to Circ. 2 output.

CAUTION Use isolation relays if connecting 3-wire zone valve end switches to the input.

LEGEND for Figure 57 and Figure 58

Note: This is a common legend for all piping diagrams. Not all items listed appear in every figure.

1 Evergreen® boiler	12 Auto air vent	21 By-pass pressure regulator, REQUIRED for zone valve systems unless other provision is made
2 Indirect Water Heater, if used	13 Zone valves	22 High limit temperature control (If used)
3 Relief valve, supplied with boiler, field piped — MUST be piped to boiler supply connection — see page 14 for information	14 Primary/secondary connection (tees no more than 12 inches apart)	23 DHW tank boiler water supply connection, when used
4 Relief valve piping to drain — see page 49	15 Expansion tank, closed type, if used (some chiller systems may use a diaphragm-type expansion tank)	24 Zone circulator
5 DHW circulator	16 Water chiller	25 DHW tank boiler water return connection, when used
6 Isolation valves	17 Check valve	26 Pressure/temperature gauge, supplied with boiler, field piped
7 System circulator	18 Y-strainer	27 Heating circuits
8 Expansion tank, diaphragm type, if used	19 Balancing valve	28 Additional heating circuits, if any
9 Air separator	20 Make-up water supply – Use applicable codes to determine if backflow preventers, pressure reducing valves, and fill valves may be required	29 Boiler circulator, if any
10 Flow/check valves		30 Mixing valve, if any
11 Purge/drain valves (one drain valve shipped loose with boiler)		31 Low Water Cut-Off



Primary/Secondary System piping *(continued)*

Circulator zoning – Multiple temperature zones with primary/secondary

(Shown with optional DHW piping)

See Figure 58.

1. This configuration is for circulator-zoned systems with **high- and low-temperature heating zones** using a boiler loop connected as a secondary circuit off of a primary system loop. Systems zoned with circulators must pipe the boiler loop as a secondary circuit as shown.
2. Install a separate circulator (supplied by installer) for each zone capable of delivering the proper flow and head as shown.

Expansion Tank required

1. Provide a system expansion tank following the guidelines on page 47 or 48.
2. **DO NOT** use a closed-type tank if connecting to a water heater that is equipped with an automatic vent.

System setup and settings

1. Hi-temp emitters may be baseboards, radiators, fan coils, or heat exchangers.
2. Add a mixing device (Figure 58, item 30) to help ensure supply water temperature will not exceed the maximum allowable for the radiant system.
3. Heating zone supply water temperature settings should be selected for the hi-temp zones. The mixing device regulates supply temperature to the lower-temp zones.

Domestic Hot Water (DHW) tank, if used

1. DHW direct connection—Pipe from the near-boiler piping to the DHW tank's boiler connections as shown.
2. DHW as zone— A DHW tank can be connected as a zone if a DHW tank is **NOT** already connected to the boiler. See notices on page 139 to ensure compliance with the 2007 Energy Act. See Advanced Manual to configure Boiler Pump to run during DHW demands and change TARGET MOD SENSOR to System Supply.
3. DHW Priority operation— Using Priority 1 for DHW (default) will turn off lower priorities during DHW calls. The MAX ON TIME setting can be adjusted to limit how long this occurs. Use Priority 2 or 3 for DHW if DHW priority is not desired.

NOTICE Overriding the Outdoor Reset function by setting control to DHW mode when system is intended for space heating may violate **Section 303 of the 2007 Energy Act**. See page 139 for compliance information and exemptions.

Controlling the circulators

1. The control can control up to four circulators (boiler circulator and three others). Refer to Field wiring, beginning on page 55, for instructions on wiring to circulators.
2. The factory default settings are: all three inputs are set up for Space Heating (Priority 2). Each input correlates to its respective circulator output. For DHW Priority applications, wire aquastat to Input 1 and assign to Priority 1. See Field wiring instructions, beginning on page 55, for details.

Figure 58 Circulator zoning with high- and low-temperature heating zones

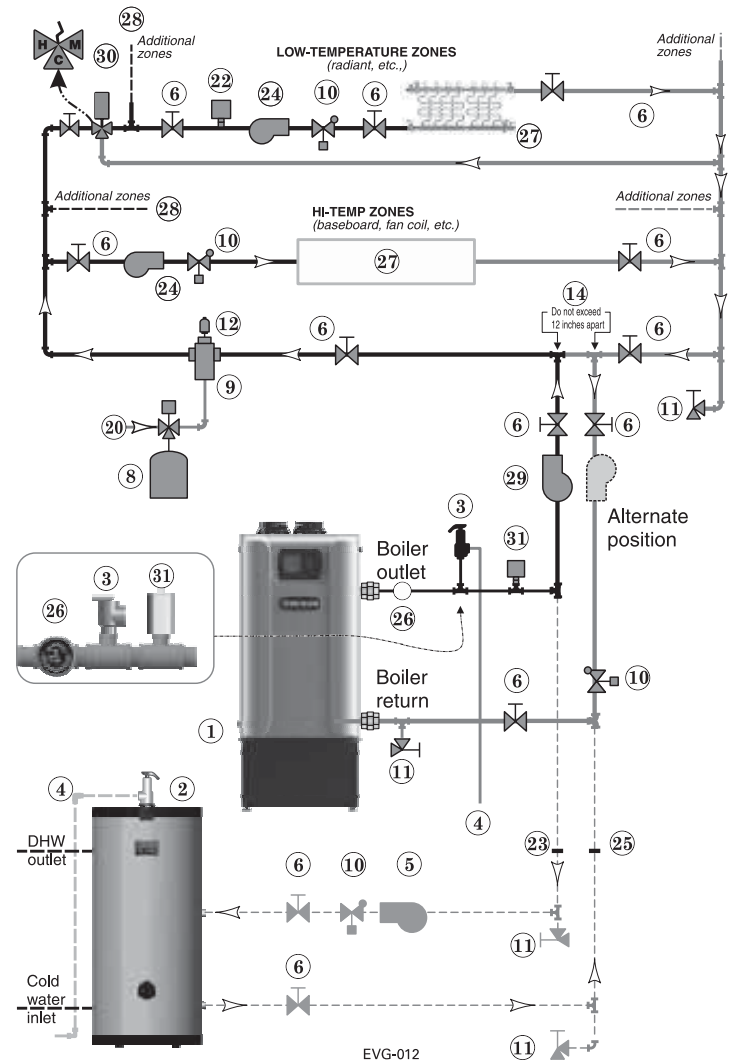

3. For more than 3-zones, use Weil-McLain WMZV zone valve controller.

NOTICE Connect zone valve end switches to Priority 2 input. Connect system circulator to Circ. 2 output.

CAUTION Use isolation relays if connecting 3-wire zone valve end switches to the input.



Install condensate line

Prepare condensate trap assembly

1. Remove the condensate trap kit from the accessories bag.
2. See Figure 59. The left image shows the complete condensate trap kit.
3. Remove the flexible drain tube nut, item 2.
4. Push the flexible tube gasket ring (item 3) onto the end of the flexible tube (item 1) as shown in Figure 59. The tube should extend through the gasket about ¼ inch.
5. Insert the flexible tube and gasket into the drain fitting. When in position, the offset edge of the gasket ring will rest on the shoulder of the drain fitting as shown in Figure 59, detail 6.
6. Secure the flexible tube in place by screwing on the nut, item 2. Finger tighten securely.

Install the condensate trap assembly

1. Remove floor stand front access panel (if installed as a floor standing boiler), see Figure 60.
2. Insert the condensate trap ball, Figure 59, item 5 into the trap body (item 4).

WARNING The condensate trap ball **MUST** be in place in the condensate trap assembly to prevent possible flue gas leakage through the condensate drain system.

3. Loosen the top nut on the trap body.
4. Slide the trap assembly onto the boiler condensate outlet. Firmly hand tighten the upper nut to secure the condensate trap in place.
5. Place the condensate bracket around the top nut and align the slot and hole with the holes in the bottom plate. Push the slotted rivet nuts through the bracket hole and slot into the holes in the cabinet.
6. If floor standing boiler, route hose through slot in side of boiler stand.

Condensate drain system

1. **Install condensate drain by connecting tubing or PVC pipe to the flexible drain line. Run the drain tubing or piping to a floor drain or condensate pump.** The flexible drain line will fit in a ¾" PVC coupling. Run minimum ½" PVC for the piping to drain or condensate pump.

NOTICE Use materials approved by the authority having jurisdiction. In the absence of other authority, PVC and CPVC pipe must comply with ASTM D1785, F441 or D2665. Cement and primer must comply with ASTM D2564 or F493. For Canada, use CSA or ULC certified PVC or CPVC pipe, fittings and cement.

2. Select a condensate pump (if used) that is approved for use with condensing boilers and furnaces. The pump should have an overflow switch to prevent property damage from condensate spillage. The pump should have a minimum capacity of 2 GPH for the EVG 70, 3 GPH for the EVG 110, or 4 GPH for the EVG 155.
3. When sizing condensate pumps, make sure to include the total load of all appliances connected to it.

CAUTION The condensate line must remain unobstructed, allowing free flow of condensate. If condensate is allowed to freeze in the line or if the line is obstructed in any other manor, condensate can exit from the boiler tee, resulting in potential water damage to property.

NOTICE Condensate from the boiler will be slightly acidic (typically with a pH from 3.2 to 4.5). Install a neutralizing filter when draining into metal pipe and if required by local codes. See Replacement parts section at the end of this manual for the Weil-McLain kit.



The condensate trap and bracket must be in place during all operation. Make sure the trap is securely attached to the condensate outlet and that the condensate discharge line is in good condition and installed per this manual. Failure to comply could result in severe personal injury, death or substantial property damage.

Figure 59 Condensate trap assembly

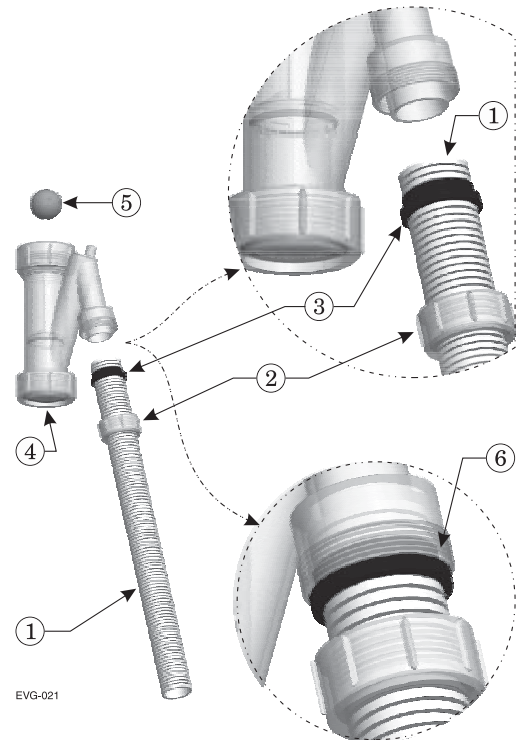
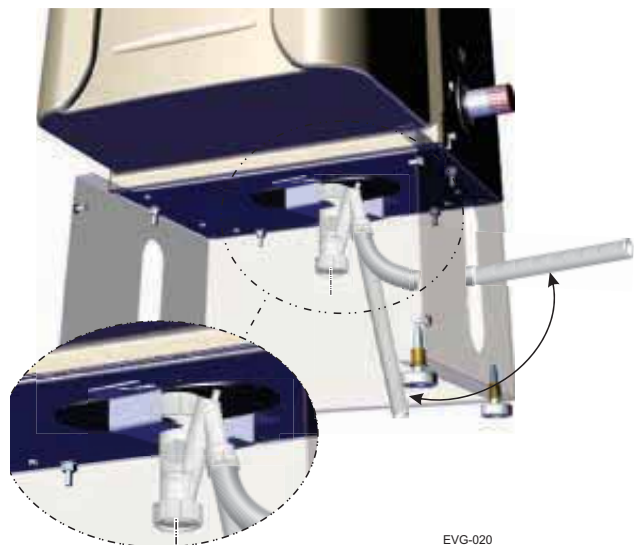

Figure 60 Condensate trap connection (front access panel removed)



Gas piping

WARNING Evergreen® boilers are shipped ready to operate on natural gas ONLY. You must install the propane orifice if the boiler will be connected to propane. See page 15. Failure to comply could result in severe personal injury, death or substantial property damage.

WARNING Use two wrenches when tightening gas piping at boiler, using one wrench to prevent the boiler gas line connection from turning. Failure to support the boiler gas connection pipe to prevent it from turning could damage gas line components.

Connecting gas supply piping

1. Remove jacket door and refer to Figure 61 to pipe gas to boiler.
 - a. Place a pipe wrench on the gas line inside the jacket when tightening the gas line assembly to the boiler gas connection (item 1).
 - b. Install steel pipe fittings and factory-supplied manual gas shut off valve as shown in Figure 61. All pipe fittings are supplied by the installer. The manual gas shut off valve is shipped loose with the boiler.
 - c. In Canada — The manual gas shut off valve (item 2) must be identified by the installer.
2. Use pipe dope compatible with propane gases. Apply sparingly only to male threads of pipe joints so that pipe dope does not block gas flow.

WARNING Failure to apply pipe dope as detailed above can result in severe personal injury, death or substantial property damage.

3. Connect gas supply piping to the ½" NPT manual gas shut off valve (item 2).
4. Support gas piping with hangers, not by boiler or its accessories.
5. Purge all air from gas supply piping.
6. Before placing boiler in operation, check boiler and its gas connection for leaks.
 - a. During any pressure testing at less than 13" (330 mm) w.c., close the gas shutoff valve and disconnect system gas piping. At higher test pressures, disconnect boiler and gas valve from gas supply piping.

WARNING Do not check for gas leaks with an open flame — use bubble test. Failure to use bubble test or check for gas leaks can cause severe personal injury, death or substantial property damage.

WARNING DO NOT adjust or attempt to measure gas valve outlet pressure. The gas valve is factory-set for the correct outlet pressure. This setting is suitable for natural gas and propane. Attempting to alter or measure the gas valve outlet pressure could result in damage to the valve, causing potential severe personal injury, death or substantial property damage.

Gas pipe sizing

1. See page 21 for gas line sizing information.

Check gas pressure at inlet to boiler

1. See Figure 86, page 96 (EVG 70), Figure 87, page 97 (EVG 110) or Figure 88, page 98 (EVG 155) for location of the gas inlet pressure test port.

Figure 61 Connect gas supply piping

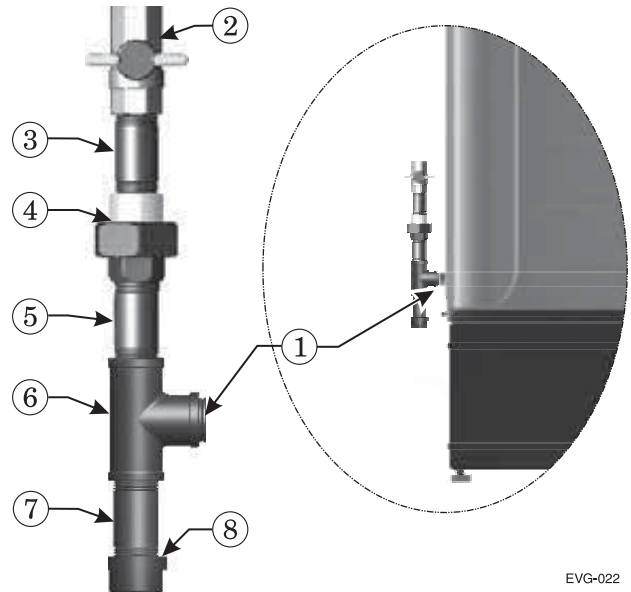

EVG-022

- 1 Boiler gas supply connection, ½" NPT male
 - 2 Manual gas shut off valve, ½" NPT, shipped loose with boiler
- ALL OF THE FOLLOWING ARE SUPPLIED BY THE INSTALLER:
- 3 Nipple, ½" NPT
 - 4 Union, ½" NPT
 - 5 Nipple, ½" NPT
 - 6 Tee, ½" NPT
 - 7 Nipple, ½" NPT x 4", for drip leg
 - 8 Cap, ½" NPT

2. For natural gas or propane, the pressure required at gas valve inlet pressure port (verify minimum gas pressure when all gas appliances are in operation):
 - a. Maximum: 13" (330 mm) w.c. with no flow (lockup) or with boiler on.
 - b. Minimum gas pressure, with gas flowing (verify during boiler startup, while boiler is at high fire) :
 - EVG 70: 3½" (89 mm) w.c.;
 - EVG 110: 3½" (89 mm) w.c.;
 - EVG 155: 3½" (89 mm) w.c.
 - c. Nominal gas pressure: 11.0" (279 mm) w.c.
3. Install 100% lockup gas pressure regulator in supply line if inlet pressure can exceed 13" (330 mm) w.c. at any time. Adjust lockup regulator for 13" (330 mm) w.c. maximum.



Field wiring

⚠ WARNING **ELECTRICAL SHOCK HAZARD** — For your safety, turn off electrical power supply at service entrance panel before making any electrical connections to avoid possible electric shock hazard. Failure to do so can cause severe personal injury or death.

NOTICE The installation must comply with: National Electrical Code and any other national, state, provincial or local codes or regulations. In Canada, CSA C22.1 Canadian Electrical Code Part 1, and any local codes.

NOTICE Wiring must be N.E.C. Class 1. If original wiring as supplied with boiler must be replaced, use only type 105 °C wire or equivalent. Boiler must be electrically grounded as required by National Electrical Code ANSI/NFPA 70 – latest edition, and/or the Canadian Electrical Code Part I, CSA C22.1, Electrical Code.

NOTICE The boiler when installed, must be electrically bonded to ground in accordance with the requirements of the authority having jurisdiction or, in the absence of such requirements, with the National Electrical Code, ANSI/NFPA 70 – latest edition, and/or the Canadian Electrical Code Part I, CSA C22.1, Electrical Code.

Evergreen® boiler wiring

Connecting terminals

All field wiring is made through the eight (8) colored connectors (shipped loose with boiler) directly to the control module. Line voltage, 120 VAC, terminals are on the top of the control module. Low voltage, 24 VAC, terminals are on the bottom of the control module.

Wire entrances

Wire entrance knockouts are provided on the top left, the bottom left side and the top right side of the boiler cabinet:

1. Line voltage— five (5) knockouts on the top left of the cabinet (Line In, Output 1, 2, 3, Boiler Circ.).
2. Low voltage— two (2) knockouts on the bottom left side of the cabinet.
3. Multiple boiler communication wiring—a single knockout on the top right of the cabinet.

⚠ WARNING Installer MUST use a strain relief through jacket knockouts. Failure to do so can cause severe personal injury, death or substantial property damage.

⚠ WARNING Installer MUST SEAL all electrical entrances using a sealed strain relief or a strain relief sealed with duct seal putty or silicone. Sealing the entrances prevents the boiler from drawing air from inside the boiler room. This is particularly important if the boiler is located in the same room as other gas appliances. Failure to seal entrances could result in severe personal injury, death or substantial property damage.

Wire routing in the cabinet

Line voltage: (120VAC in, circulator outputs)

1. Install four (4) of the wire tie bases to the holes on the left side interior of the cabinet.
2. Line voltage should be wired from the top left electrical entrances following the left side of the cabinet.
3. Wires should be bundled together and secure with the provided wire ties to the wire tie bases located on the left side wire chase. Two (2) sets of bases are provided, one (1) for line in and one (1) for the circulator outputs. Route wires in front of the transformer then into terminal blocks.
4. Strip end of wire no more than 1/8" to avoid exposing uninsulated wire.
5. It is recommended to install an On/Off service switch in a junction box mounted near the boiler. Installation must meet all National and local electrical codes.

Low voltage:

1. Mount low voltage wire grommet to desired low voltage knockout.
2. Thermostat, aquastat, limit devices, system sensors, 0-10VDC input and outdoor temperature sensor wire pairs should be routed through the grommet.
3. Wires should be connected directly into the corresponding terminal block.
4. Low water cutoff should be routed following the instructions in step 3. Provide strain relief and a seal at cabinet entry.
5. Bundle all wires together with provided wire ties.
6. After wires are attached to the control terminal blocks, make sure wires are properly sealed in the cabinet electrical entrances.



Field wiring *(continued)*

Multiple boiler communication wiring

1. Wires should be shielded thermostat wires, or equivalent.
2. Route wires through top right knockout to communication board on display bracket.
3. Provide strain relief and seal at cabinet entry.

Figure 62 Field wiring overview (see Figure 63, page 63 and Figure 64, page 64 for detailed schematic and ladder wiring diagrams) EVG -155 shown

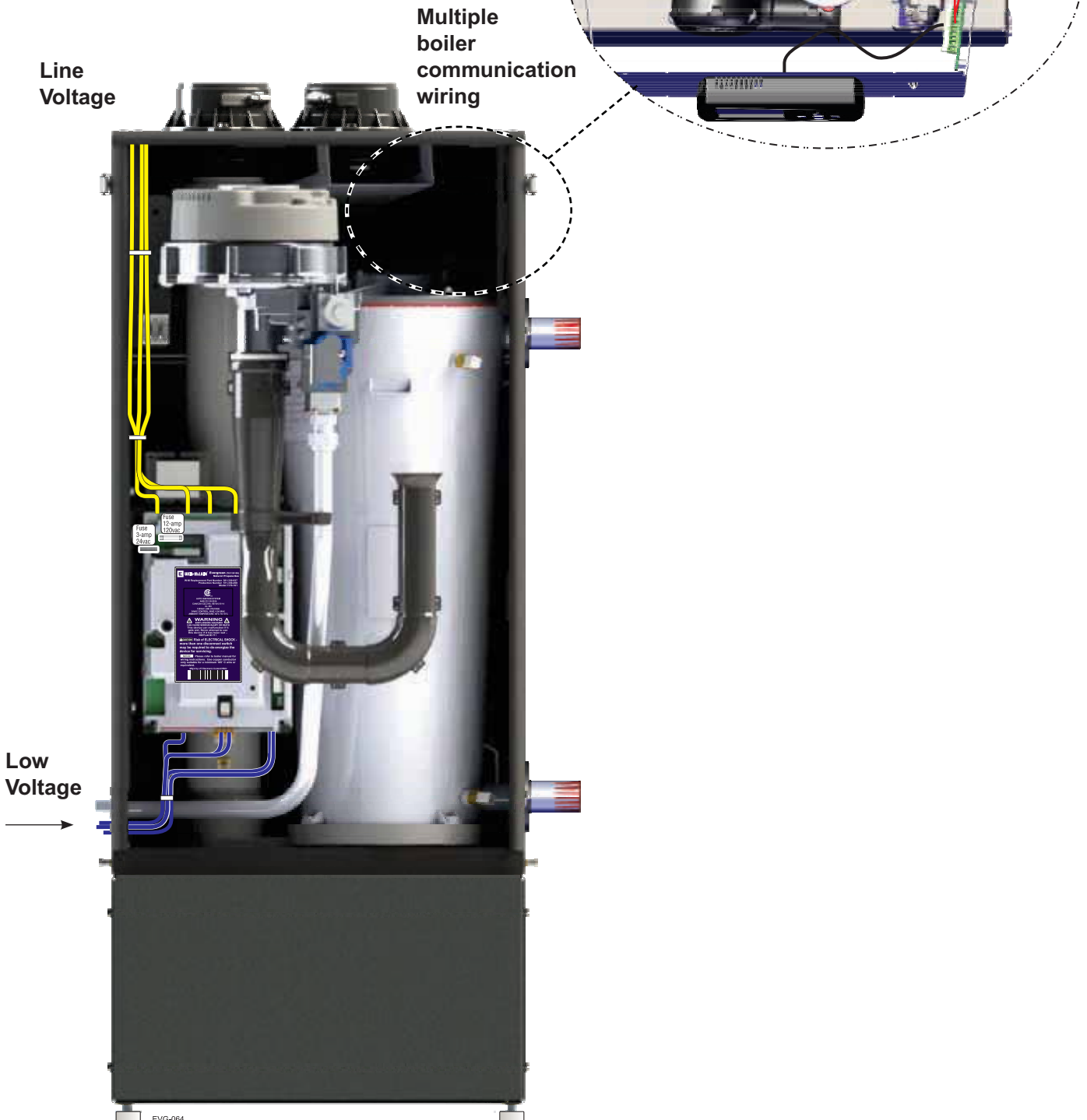



Field wiring (see wiring diagram, Figure 63, page 63) (continued)

A. 120 VAC Power Supply – REQUIRED

Terminal Strip P1 (EVG control module)

- Provide and install a properly-sized, fused disconnect or service switch as required by applicable codes. (15-amp for most cases.)
 - Use table at right to determine total load.
- Connect properly sized 120 VAC power wiring to Evergreen® boiler line voltage terminal block as shown at right.
- If possible, provide a surge suppressor in the supply power line. This will reduce the possibilities of control damage due to line surges.
- Must wire ground to this terminal to provide boiler grounding.

Determine total load	
Boiler & boiler pump (combined load)	5.6 amps
Output 1 (2.2 amps max)	___ amps
Output 2 (2.2 amps max)	___ amps
Output 3 (2.2 amps max)	___ amps
TOTAL	___ amps



See Figure 63, page 63 for details

B. 120 VAC Outputs 1, 2 & 3 – As needed for systems

Terminal Strip P2 (EVG control module)

- Output 1: P2 Terminals 1 (H), 4 (N), 7 (G).
- Output 2: P2 Terminals 2 (H), 5 (N), 8 (G).
- Output 3: P2 Terminals 3 (H), 6 (N), 9 (G).
- Maximum load: 2.2 amps (use relay if circulator load is higher). See WARNING below.
- These three outputs (Output 1, Output 2, and Output 3) can provide 120VAC to the following listed below.
 - A zone circulator.
 - A system circulator.
 - A DHW circulator (used to circulate through an indirect tank).
 - An auxiliary item that must be energized during an input call, such as an air damper.
- When using inputs/outputs for heat/DHW demands, each input (Input 1, Input 2, and Input 3) controls its respective 120VAC output (Output 1, Output 2, and Output 3). Outputs are energized only when BOTH conditions below are met:
 - The corresponding input indicates a call for heat/DHW (i.e. contact closure).
 - The PRIORITY assigned to the Input/Output pair is ACTIVE (i.e. the zone may be calling but the pump won't activate unless the boiler is currently running on that system/priority).
- When using the inputs/outputs for the AUX PUMP/OUTPUT function, the output is controlled by selectable conditions set up in the control.
 - Use the AUX PUMP/OUTPUT function for devices such as system pumps, combustion air dampers, and other auxiliary equipment to activate when the boiler is on/running.
 - See page 82 and page 83 for more information on the setup and selection of operating conditions.

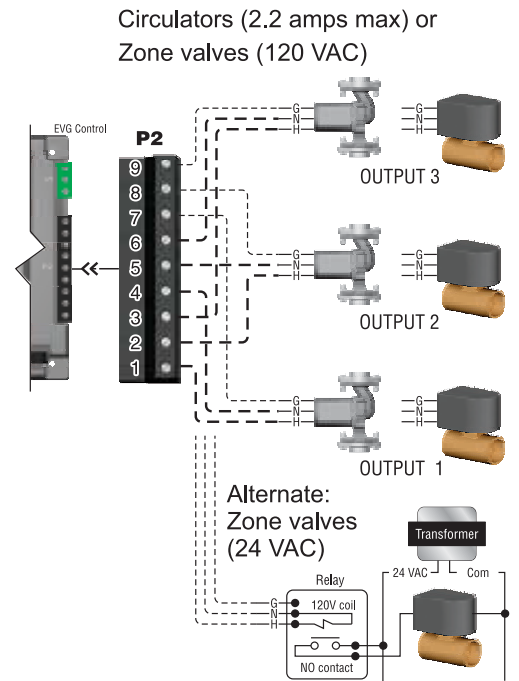

See Figure 63, page 63 for details.

NOTICE

For Priority DHW Application:

The DHW aquastat can be connected to any one of the three input/output pairs. The selected input should be assigned to PRIORITY 1 during the WIZARD setup or manually in the ASSIGN INPUTS menu.

WARNING

Output circuits are 120 VAC. If an output is to operate a low voltage circuit or must be an isolated contact, use an isolation relay.

WARNING

CIRCULATOR POWER — The maximum allowable current for each circulator is 2.2 amps at 120 VAC.

For circulators with higher amp ratings, install a circulator relay or starter. Connect only the 120VAC coil to the Evergreen circulator terminals.



Field wiring *(see wiring diagram, Figure 63, page 63) (continued)*

C. 120 VAC to Boiler Circulator — REQUIRED

Boiler circulator terminal block to P4 on Control module *(terminal block)*

1. Provides 120VAC to the boiler circulator at Boiler circulator terminal.
2. Terminals are: 1 (H), 2 (N), 3 (G).
3. Maximum load: 2.0 amps (use relay if circulator load is higher). See WARNING above.
4. The boiler circulator (shipped loose with boiler) is used in the boiler loop of the primary/secondary piping. Primary/secondary piping is required to be used with the Evergreen® boiler to ensure proper flow through the heat exchanger.

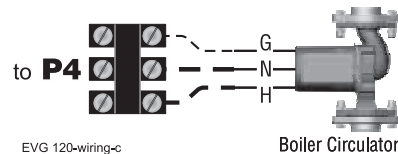

See Figure 63, page 63 for details.

D. Inputs 1, 2 and 3 (tstats, end switches, etc.) — As needed for systems

Terminal Strip P11 (input 1) & Terminal Strip P15 (inputs 2 & 3) *(EVG control module)*

1. Input 1 — Terminal Strip P11 — 4 & 5 (EVG control module)
2. Input 2 — Terminal Strip P15 — 1 & 2 (EVG control module)
3. Input 3 — Terminal Strip P15 — 3 & 4 (EVG control module)
4. These three inputs on each boiler can indicate a call for heat to the control by means of a dry contact closure (thermostat, aquastat, or switch). (See right and Figure 63, page 63).
5. The control provides inputs for up to three zones or three systems (priorities).

NOTICE The control default setting is for three space heating zones tied to PRIORITY 2, which is defaulted to FINNED TUBE BASEBOARD system type.

6. For DHW applications, the aquastat can be connected to one of the three input/output pairs. Take advantage of factory default settings by using PRIORITY 1 for the DHW system. The default control setting for PRIORITY 1 is a direct-piped DHW system type.
7. The default control setting uses each input (INPUT 1, INPUT 2, and INPUT 3) to control its respective 120VAC output (OUTPUT 1, OUTPUT 2, and OUTPUT 3).

NOTICE Use of 0–10VDC input for modulation disables Input 1 from creating calls for heat. See page 62 for instructions.

An input can be assigned to an AUX PUMP/OUTPUT function to operate a system pump or interlock with a combustion air damper. Inputs assigned for this function cannot be used for heat demand operation. See page 82 and page 83 for more information on the setup and selection of operating conditions.

TT or end switch inputs

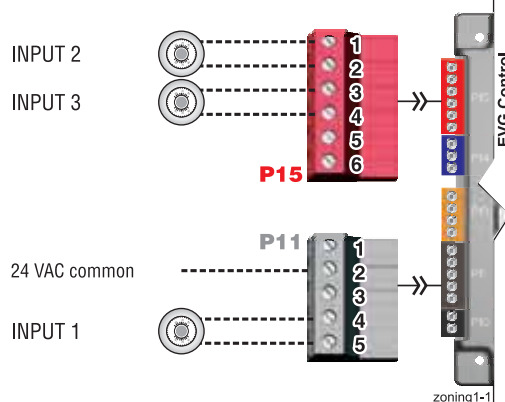

See Figure 63, page 63 for details.

WARNING **Thermostats** — DO NOT supply 24-volt power to the thermostat circuits (Input1, Input2 and Input3 in Figure 63, page 63) or attempt to supply 24 volts for any other application.

For thermostats that require a continuous 24-volt power source, connect the common wire (“C”) to P11 Pin 2 (see Figure 63, page 63). Do NOT exceed total amp draw per thermostat.

Zone valves — If using 3-wire zone valves, use relays to provide dry contacts to the Control thermostat connections. The zone valve end switches of 3-wire valves carry 24 VAC from the valve.

Thermostat anticipator setting — 0.1 amps.



Field wiring *(see wiring diagram, Figure 63, page 63) (continued)*

E. System supply and return temperature sensors – REQUIRED

Terminal Block P14 (EVG control module)

- Two strap-on temperature sensors are shipped with the boiler. Attach one to the system supply piping and the other to the system return piping. For piping larger than 5 inch diameter or nonmetallic piping, using immersion sensors will provide faster response.
- Locate the supply sensor at least six pipe diameters, but no further than 3 feet, downstream from the boiler connection to the main to ensure adequate mixing.
- Supply sensor – wire between P14 #1 and #2 (common).
- Return sensor – wire between P14 #3 and #2 (common).
- Thermostat wire can be used to connect these sensors.
- The Control compares the system return temperature with the system supply temperature. Should the return temperature ever exceed the supply temperature, the Control knows there is likely a sensor failure and will report this problem on the display.

NOTICE All primary/secondary heating systems shown in this manual require the System Supply and Return sensors to be installed for proper control function. System will not properly provide heat if sensors are not installed according to these instructions.

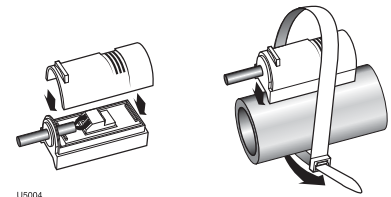

Strap to supply & return piping

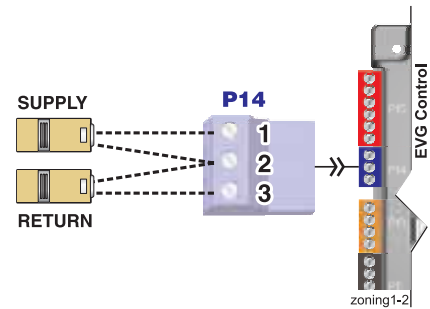

See Figure 63, page 63 for details.

F. Outdoor temperature sensor – REQUIRED unless exempted

Terminal Block P10 (EVG control module)

- The control provides programmable options if using an outdoor temperature sensor. This sensor is supplied with the boiler.
- The outdoor sensor must be installed unless specifically exempted in the Energy Act statement on page 139.**
- Mount the outdoor sensor on an exterior wall, shielded from direct sunlight or flow of heat or cooling from other sources.
- The wire outlet on the sensor must be oriented DOWN to prevent water entry.
- Connect the sensor leads to the terminal shown at right and in the wiring diagrams (see Figure 63, page 63). Thermostat wire can be used to connect the sensor.

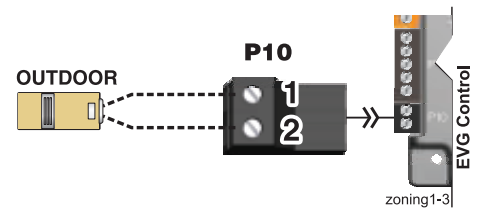

See Figure 63, page 63 for details.

G. External limits – OPTIONAL

To cause MANUAL reset: Terminal Block P13 #1 & #2 (EVG control module)

EVG control will require manual reset after circuit is interrupted.

- Remove factory-installed jumper and connect isolated contacts of external limits across P13 pins 1 and 2 to cause the control to enter manual reset lockout if the limit circuit opens. The limit must close and the control must be manually reset using the procedure given in this manual. See drawing at right and wiring diagram Figure 63, page 63.

NOTICE The control will lockout when a limit in its manual reset circuit opens (P13 pins 1 & 2). The control activates its alarm terminals and shuts the boiler down. An operator (user or technician) must manually reset the control to restart the boiler.

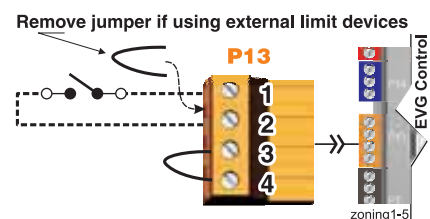

See Figure 63, page 63 for details.



Field wiring *(see wiring diagram, Figure 63, page 63) (continued)*

To cause **AUTOMATIC** reset: Terminal Block P13 #3 & #4 *(EVG control module)*

EVG control will reset automatically after circuit is interrupted.

1. Remove factory-installed jumper and connect isolated contacts of external limits across P13 pins 3 and 4 to cause the control to shut down the boiler on limit opening, then automatically restart 150 seconds after the limit closes.
2. See drawing at right and wiring diagram (Figure 63, page 63).

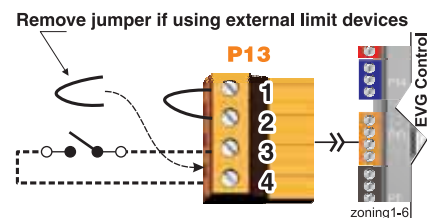

See Figure 63, page 63 for details.

H. Low water cutoff – Standard Equipment

Terminal Block P12 *(EVG control module)*

1. Install a low water cut-off when required.
2. Wiring Weil-McLain LWCO Kit:
 - a. When possible, use the Weil-McLain Low water cut-off kit listed in the back of this manual. It includes a probe-type low water cut-off and provides a simple harness connection for the wiring.
 - b. Connect as shown at top right and in the control wiring diagram (Figure 63, page 63).
 - c. The Weil-McLain Low water cut-off kit is included with the boiler.
3. Wiring another LWCO — must have isolated contact:
 - a. Other low water cut-offs can be used with the EVG only if the device uses an isolated contact for the LWCO function.
 - b. Connect as shown at bottom right.

Wiring for Weil-McLain LWCO Kit

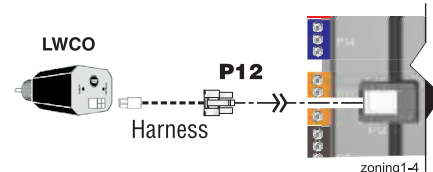

Wiring other isolated contact LWCO

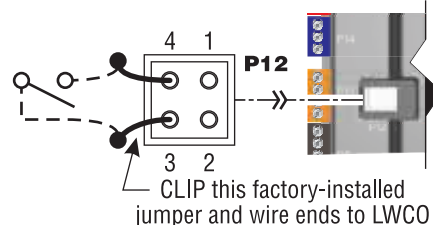

See Figure 63, page 63 for details.

I. Alarm contacts – OPTIONAL

Terminal Block P16 #4 & #5 *(EVG control module)*

1. The control's alarm dry contact (P16, terminals 4 and 5) closes when the boiler enters manual lockout only.
2. Connect these terminals for remote alarm notification.
3. Contact electrical ratings: 24VAC or less; 0.5 amp or less.

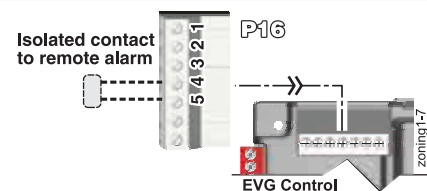

See Figure 63, page 63 for details.

J. Additional heat demand contacts – OPTIONAL

Terminal Block P16 #6 & #7 *(EVG control module)*

1. The control module can be set to activate another heat source using its additional heat demand dry contacts through terminal block P16 pins 6 & 7.
2. Connect these terminals to call for heat from the other heat source.
3. Contact electrical ratings: 24VAC or less; 0.5 amp or less.
4. Set the control to activate the heat demand contacts as needed.
5. See EVG Advanced Manual to configure.

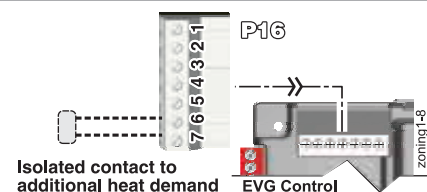

See Figure 63, page 63 for details.



Field wiring (see wiring diagram, Figure 63, page 63) (continued)

K. Proof of closure (flow switch and/or CAD) – see ADVANCED Manual – OPTIONAL

Jumper on Terminal Strip P7 (EVG control module)

1. A flow switch or combustion air damper (CAD) interlock can be configured by clipping the jumper on terminal strip P7 and wiring components as shown at right and in the wiring diagram (Figure 63, page 63).
2. No control settings are required when using a flow switch.
3. Recommended configuration of the EVG control for a CAD interlock:
 - a. Assign **INPUT 3** as a **AUX PUMP/OUTPUT** function.
 - b. For the **AUX PUMP/OUTPUT** operating mode, select **ANY BURNER DEMAND**. This ensures the damper will be activated any time the boiler is called on to fire.
 - c. **OUTPUT 3** will provide 120VAC to the damper motor. Use an isolation relay if damper motor requires another voltage or more than 2.2 amp if using 120 VAC.

NOTICE * The devices used must provide electrically isolated contacts, because the P7 jumper circuit carries 5 VDC.

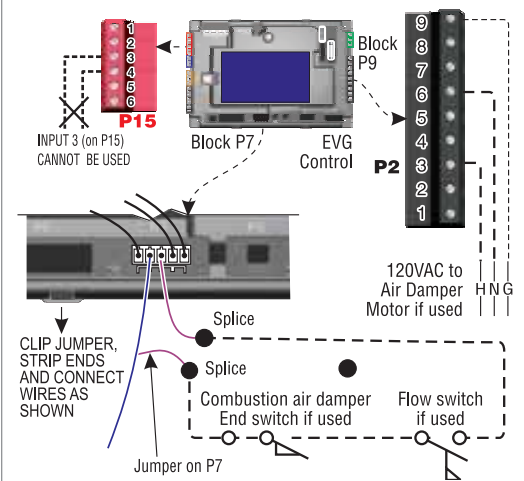

See Figure 63, page 63 for details.

L. 0–10 VDC Remote TARGET input – OPTIONAL

Terminal Block P15 #5 & #6 (EVG control module)

1. See illustration at right and Figure 63, page 63 (wiring diagram) for details.
2. Remote target using 0–10VDC input requires a 0–10VDC input signal at P15-4/5 as shown at right.
 - a. The input positive connection must be at P15 terminal 6 and the common connection at terminal 5.
3. This illustration also shows how to connect TT or end switch contacts at INPUT 1, INPUT 2 and INPUT 3.
 - a. If a Heat/DHW demand is required, connect the demand’s dry contact to an unused input on the control and its pump/valve to the respective output. Then assign and setup a priority to the input using the Wizard or manually through the contractor menu.
 - b. A dry contact heat demand must be applied to one of the inputs in order to initiate a call for heat.
4. The 0–10VDC signal is used to adjust the supply target temperature, using the TARGET ADJUST setting. Set TARGET ADJUST during the WIZARD or manually in the PRIORITY SETTINGS menu for the desired system/ priority.
 - a. Many options are available for configuring the control. The following is a suggested setup that uses factory default settings as much as possible.
 - b. Use PRIORITY 1 for the DHW heating system when used. This priority’s default values are set for DHW, direct-piped to the boiler. Verify that settings are suitable for the application, change if needed.
 - c. Use PRIORITY 2 for the heating systems.
 - For single boilers, the factory default settings for PRIORITY 2 make this priority a good choice for space heating applications. Set PRIORITY 2 values to the following:
 - Set TARGET ADJUST value to 0–10V.
 - Set VOLTS FOR MAX at the voltage that will call for the highest target temperature. Set SUPPLY MAX at this temperature.
 - Set VOLTS FOR MIN at the voltage that will call for the lowest target temperature. Set SUPPLY MIN at this temperature.
 - For voltages between VOLTS FOR MAX and VOLTS FOR MIN, the target temperature will range proportionately between SUPPLY MAX and SUPPLY MIN. See the EVG Advanced Manual for a full discussion.
 - NOTE: The 0–10VDC signal replaces the ODT sensor as the target temperature modifier (TARGET ADJUST setting). The EVG control does not control target.

TT or end switch inputs (INPUTS 1, 2, and 3)
With External 0–10VDC input

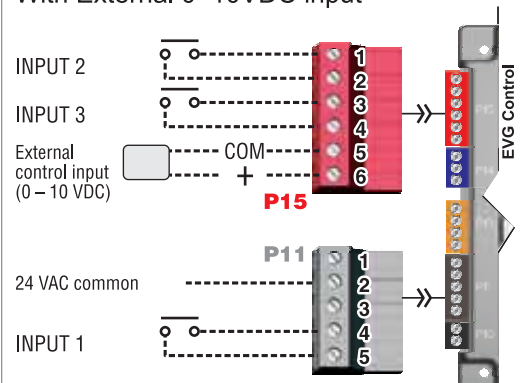

See Figure 63, page 63 for details.



Field wiring *(see wiring diagram, Figure 63, page 63) (continued)*

M. 0–10 VDC Remote MODULATION input – OPTIONAL

Terminal Block P15 #5 & #6 (EVG control module)

1. See illustration at right and Figure 63, page 63 for details.
2. This illustration also shows how to connect TT or end switch contacts at INPUT 2 and INPUT 3 for other uses.
3. Note that using 0–10VDC input replaces INPUT 1 for generating a heat demand. Do not wire any input to INPUT 1 as shown at right.
4. Remote modulation requires a 0–10VDC input signal at P15-4/5 as shown at right.
 - a. The 0–10VDC input positive connection must be at terminal 6 and common connection at terminal 5.
5. Control setup:
 - a. Many options are available for configuring the control. The following is a suggested setup that uses factory default settings as much as possible.
 - b. Default is BASIC in the Contractor menu.
 - c. If DHW is required, use PRIORITY 1 to minimize setup steps.
 - Connect the DHW aquastat to INPUT 2 or INPUT 3 and assign the input used to PRIORITY 1.
 - Verify that control settings are suitable for the application, change if necessary.
 - d. Use PRIORITY 2 for the system to be remote modulated.
 - The factory default settings for this priority are best suited for space heating.
 - Assign INPUT 1 to the priority chosen. Accept all defaults for INPUT 1 — no changes should be necessary during the WIZARD.
 - After the WIZARD has been completed, go to the ASSIGN INPUTS menu for INPUT 1. Change SOURCE to 0–10V (default setting is TT1). See page 82 for ASSIGN INPUTS menu information.
6. Operation:
 - a. The boiler comes on at 0.9VDC and turns off at 0.8VDC. 2 VDC = 20% input. 10 VDC = 100% input. These voltage settings are not adjustable.
 - b. OUTPUT 1 (120VAC) is activated and deactivated as the heat demand is turned on and off. This output is a good choice to operate the system pump.
7. NOTE: The EVG control can be configured to use either 0–10VDC for target operation (see previous section) or modulation, **but not both**.

TT or end switch inputs (INPUTS 2, 3)
With External 0–10VDC input

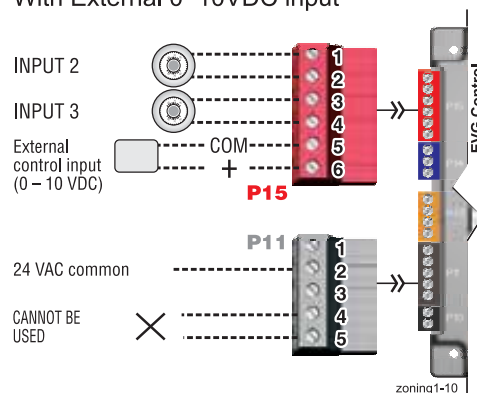

See Figure 63, page 63 for details.

N. Multiple Boiler and BMS Connections – see ADVANCED Manual

Terminal Strip JP4 on Comm Board (display bracket, right side)

1. The boiler control is capable of multiple boiler communication and control of up to eight Evergreen boilers in one installation.
2. The boiler control is also capable of BMS communication.
3. The boiler control is also capable ZoneStacking™:
 - Uses All boiler inputs, not just the first and last boilers, up to 24 customizable inputs across boiler network (3 per unit, maximum of 8 boilers on the network).
4. See Evergreen Advanced Manual for multiple boiler installation and setup information.

See EVG Advanced Manual for details.



Wiring diagram — schematic

Figure 63 Schematic wiring diagram (see Figure 64, page 64 for legend and notes)

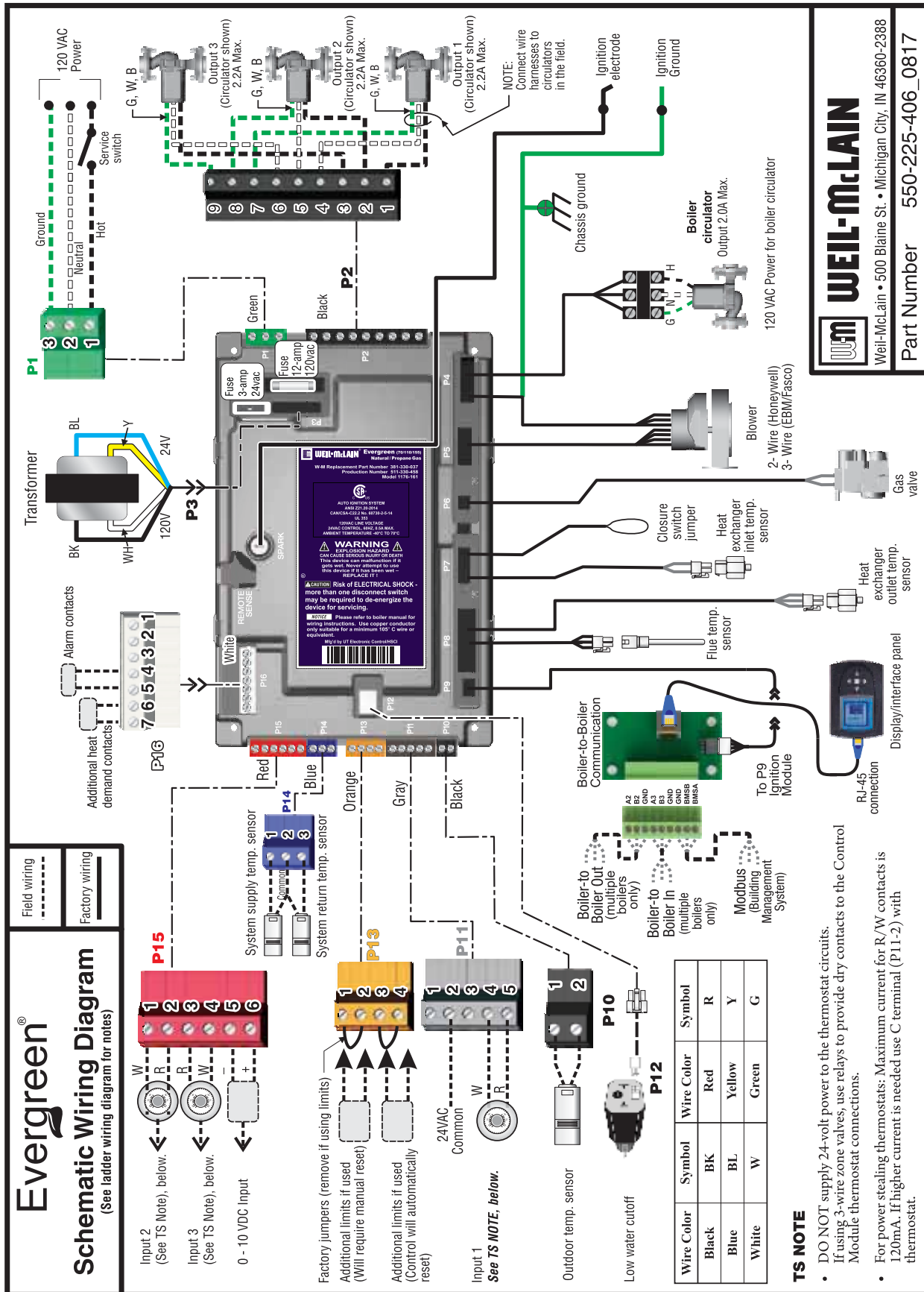

WEIL-McLAIN
 Weil-McLain • 500 Blaine St. • Michigan City, IN 46360-2388
 Part Number 550-225-406_0817



Wiring diagram — ladder

Figure 64 Ladder wiring diagram (see Figure 63, page 63 for schematic wiring diagram)

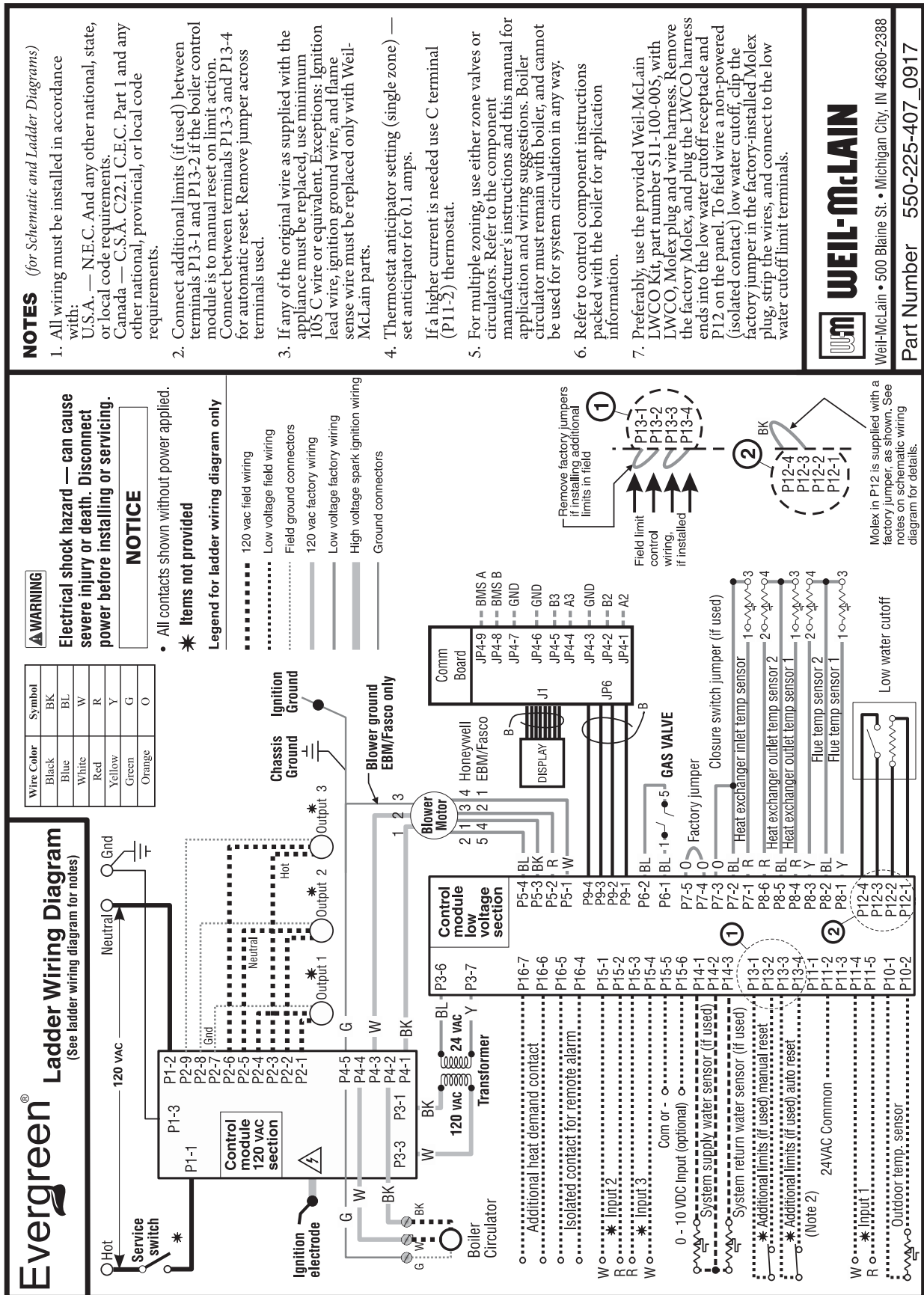

WEIL-McLAIN

Weil-McLain • 500 Blaine St. • Michigan City, IN 46360-2388
Part Number 550-225-407_0917



Zoning with the EVG Control

A. Zoning with CIRCULATORS, suggested applications

Three space heating zones (no DHW)

1. Review wiring information on page 57 (120VAC outputs) and page 58 (24VAC inputs).
2. The configuration at right uses the three input/output pairs to receive thermostat inputs on P11-4/5, P15-1/2, and P15-3/4; and circulator outputs on P2 as shown.
3. The factory default settings assign all inputs 1, 2 and 3 to PRIORITY 2.
4. Choose the space heating system type that matches the heating system during the WIZARD setup or manually in the PRIORITY 2 menu.
5. Use the factory default settings for the system type chosen, or change if needed.
6. Factory defaults should work for other settings not listed above.

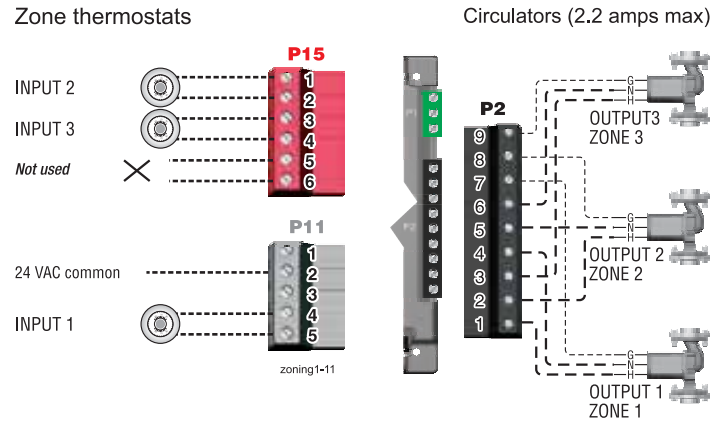

Two space heating zones plus DHW piped directly to boiler

1. Review wiring information on page 57 (120VAC outputs) and page 58 (24VAC inputs).
2. The configuration at right uses INPUT 2 and 3 for space heating thermostats. INPUT 1 uses the input from a DHW aquastat.
3. The factory default settings assign inputs 1, 2 and 3 to PRIORITY 2. Keep inputs 2 and 3 assigned to PRIORITY 2. To set up PRIORITY 2, choose the space heating system type that matches the heating system during the WIZARD setup or manually in the PRIORITY 2 menu.
4. Assign INPUT 1 to PRIORITY 1, which is factory default configured for DHW applications.
5. Use the factory default settings for DHW and for the heating system type chosen, or change if needed.
6. Factory defaults should work for other settings not listed above.

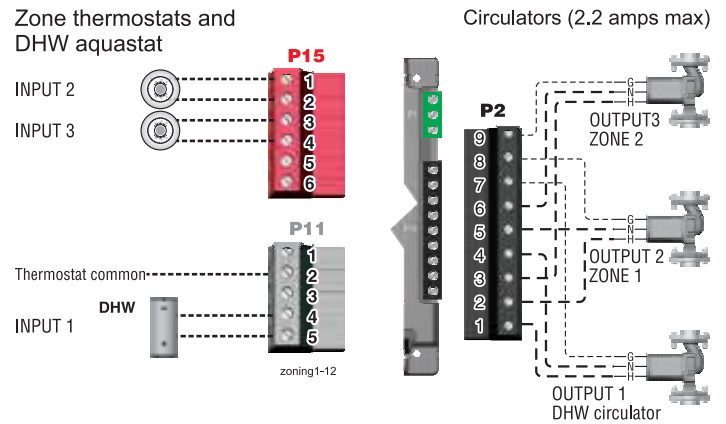

WMCR circulator zone controller plus DHW controlled by boiler, DHW piped directly to boiler

1. Review wiring information on page 57 (120VAC outputs) and page 58 (24VAC inputs).
2. To shut down Space Heating during DHW operation: Provide and connect relay R1 (120VAC coil with NC contact) to interrupt the Zone controller's ZC-ZR (120VAC operating circuit).
3. The configuration at right uses INPUT 2 for space heating with the call for heat coming from the zone controller (X-X). INPUT 1 uses the input from a DHW aquastat.
4. The factory default settings assign inputs 1, 2 and 3 to PRIORITY 2. Keep input 2 assigned to PRIORITY 2. To set up PRIORITY 2, choose the space heating system type that matches the heating system during the WIZARD setup or manually in the PRIORITY 2 menu.
5. Assign INPUT 1 to PRIORITY 1, which is factory default configured for DHW applications. Wire the DHW circulator to OUTPUT 1.
6. Use the factory default settings for DHW and for the heating system type chosen, or change if needed. Factory defaults should work for other settings not listed above.

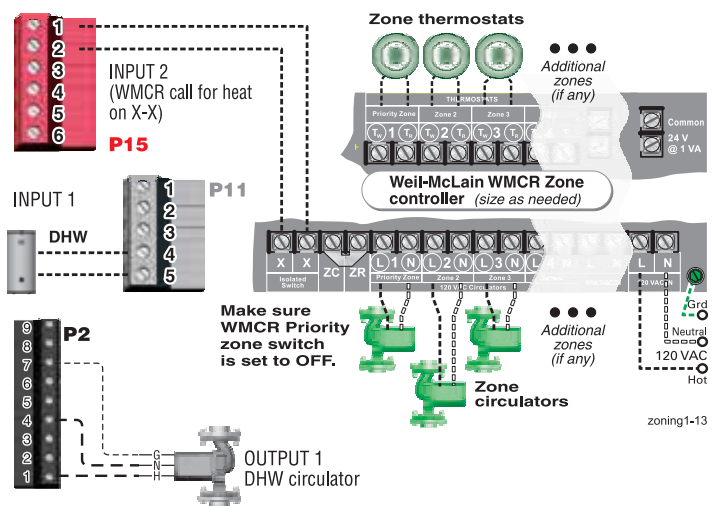

P15, P11 and P2 are terminal strips on the EVG control.



Zoning with the EVG Control *(continued)*

B. Zoning with ZONE VALVES, suggested applications

Two space heating zones (no DHW)

- Review wiring information on page 57 (120VAC outputs) and page 58 (24VAC inputs).
- The configuration at right uses INPUT 2 and 3 for space heating thermostats. INPUT 1 is reserved here for configuring the operation of the system circulator.
- The factory default settings assign inputs 1, 2 and 3 to PRIORITY 2. Keep inputs 2 and 3 assigned to PRIORITY 2. To set up PRIORITY 2, choose the space heating system type that matches the heating system during the WIZARD setup or manually in the PRIORITY 2 menu.
- Use the factory default settings for the heating system type chosen, or change if needed.
- Assign INPUT 1 to AUX PUMP/OUTPUT. Then select ANY INPUT BY ITS PRIORITY when prompted for when to activate the output. This will cause the system pump to run when either of the zones calls for heat. Confirm that Priority 2 RUN AUX PUMP/OUT is set to YES.
- INPUT 1 (P11-4/5) cannot be used for a wired connection (as shown at right) because it is being used in the control setup to run the system circulator.
- Factory defaults should work for other settings not listed above.

WARNING The system must be equipped with a by-pass pressure regulating valve. Flow can occur with zone valves closed.

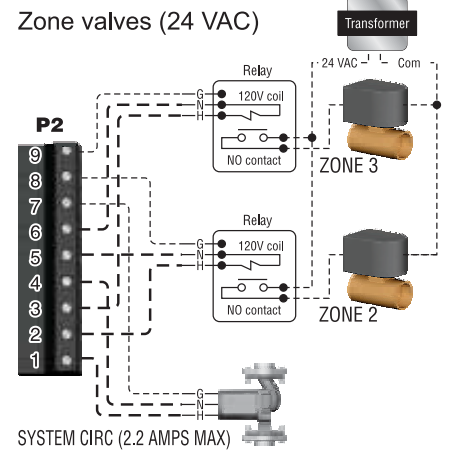
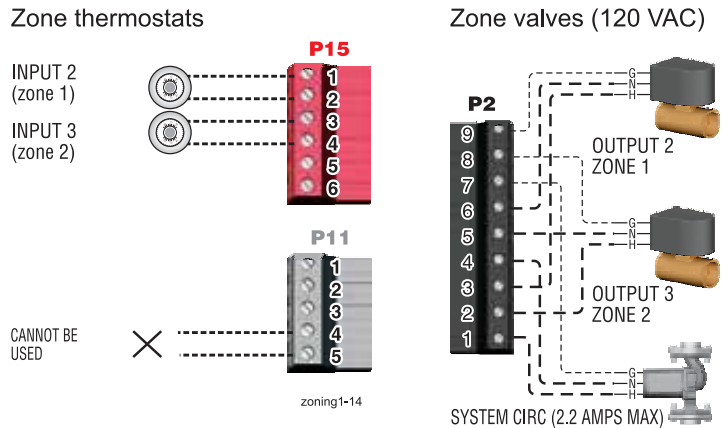

WMZV zone valve zone controller plus DHW controlled by boiler, DHW piped directly to boiler

- Review wiring information on page 57 (120VAC outputs) and page 58 (24VAC inputs).
- The configuration at right uses INPUT 2 for space heating with the call for heat coming from the zone controller (X-X). INPUT 1 uses the input from a DHW aquastat.
- The factory default settings assign inputs 1, 2 and 3 to PRIORITY 2. Keep input 2 assigned to PRIORITY 2. To set up PRIORITY 2, choose the space heating system type that matches the heating system during the WIZARD setup or manually in the PRIORITY 2 menu.
- The system circulator, wired to OUTPUT 2, will turn on whenever there is a call for heat from the zone controller.
- Assign INPUT 1 to PRIORITY 1, which is factory default configured for DHW applications. Wire the DHW circulator to OUTPUT 1.
- Use the factory default settings for DHW and for the heating system type chosen, or change if needed. Factory defaults should work for other settings not listed above.

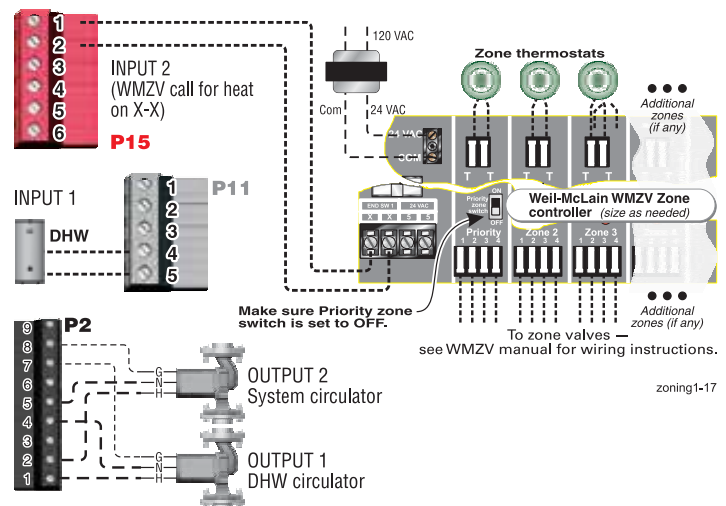

P15, P11 and P2 are terminal strips on the EVG control.



Evergreen control operation

Evergreen control setup

1. Set control parameters using the WIZARD option provided on initial start-up or manually enter parameters using control menus (see Figure 72, page 79 and following pages for information.)
2. See **Express setup** instructions beginning on page 72 for basic systems and minimum settings required (using factory defaults).
3. This manual provides set-up information for a single boiler using BASIC control setting options. See the EVG Advanced Manual for single-boiler advanced settings and for all multiple boiler applications.



Boiler Model, Altitude and Fuel Type are critical settings.

Failure to set correctly could result in severe personal injury, death or substantial property damage.

Temperature settings — You must ensure that the Evergreen control is set for the proper water temperatures for the system. Excessive water temperature can cause significant property damage in some applications.

Multi-temperature systems — If the heating system includes circuits that require lower temperature water (radiant slab circuits, for example) as well as higher temperature circuits (DHW, finned tube baseboard, etc.), it is recommended to protect low-temperature circuits with limit controls that are wired to an Evergreen® control external limit circuit. Failure to provide regulation can result in substantial property damage.

Control features

- Single or multiple boiler control (with lead boiler rotation).
- Graphic and robust text display for ease of operation monitoring and troubleshooting.
- Three programmable priority assignments for up to three heat inputs.
- Preset operating parameters for typical heating systems, including target temperatures, reset curves and circulator assignments.
- Integral outdoor reset option, with reset curves matched to the system type selected.
- ModBus communications for external communication and monitoring.
- 0-10VDC input modulation or remote target input.
- Four pump outputs, including 1 boiler pump output.
- Additional heat demand operation to call a second heat source to help supply the energy required for heating.
- Advanced PI response to anticipate system needs.
- Flue temperature modifier to target temperature.
- Modulation based on flue sensor and boiler/system supply/return sensors.
- Integral low water protection by monitoring heat exchanger temp.
- Dual temperature sensors on boiler outlet and flue, providing redundant protection.
- Boiler is shipped with an outdoor sensor and strap on system supply and return sensors.
- Blower speed modulation to control boiler firing rate.
- Alarm relay on error/fault for use with an audible safety.
- ZoneStacking™ – Uses All boiler inputs, not just the first and last boilers, up to 24 customizable inputs across boiler network (3 per unit, maximum of 8 boilers on the network).
- SmartSequencing™ – Uses a low firing rate setting, called BASERATE LOW, to keep boilers at a low firing rate, bringing on additional boilers at reduced rate until all boilers are on if necessary. Boilers are then allowed to modulate together as high as necessary to meet demand.

Sequence of operation

1. Figure 65 is a summary of the operating sequence for the Evergreen® control.
 - The statuses shown appear in the display as the Evergreen® control cycles the boiler. See Figure 69, page 71 for screen shots.
 - The display will flash red if a problem has been detected.

Figure 65 Control sequence of operation

Display status text	Control action <i>(also see Figure 69, page 71)</i>
POWER UP	<ul style="list-style-type: none"> • Check the boiler model listed on the power-up screen. If it is not correct, turn off the boiler. See page 80 for instructions to change setting. • When power is turned on, the screen lists sensors that are detected. If any sensor is not listed, make sure it is connected correctly. Turn off power and restart.
Standby	<ul style="list-style-type: none"> • Standby - no calls for heat. • Toggles through no dots, 1 dot, 2 dots, then 3 dots while in standby (wrench symbol will show instead if maintenance is needed).
Blower ON	<ul style="list-style-type: none"> • Call for heat detected. • Display on with BLUE light (space heating) or PURPLE light (DHW). • Start min/max timers if more than one system is calling - highest priority starts first. • Start circulators for this priority setup based upon settings. • Calculate target temp — If sensor temp is below target temp, begin firing sequence. • Blower to ignition speed for prepurge.
Ignition	<ul style="list-style-type: none"> • After prepurge times out, begin ignition cycle. • Activate gas valve and ignition spark. • Continue ignition spark for ignition period. • Turn off spark and use electrode to check for flame signal.
Space Heating	<ul style="list-style-type: none"> • Flame detected. • Release boiler to modulation. • NOTE: If flame is not detected, the gas valve is turned off, blower turns on (postpurge), and control starts cycle again. After 5 failures, the control waits 60 minutes, then tries again. • If priority timer times out, switch to next priority and start priority timer. • If demand satisfied, go to postpurge.
DHW Heating	<ul style="list-style-type: none"> • Flame detected. • Release boiler to modulation. • NOTE: If flame is not detected, the gas valve is turned off, blower turns on (postpurge), and control starts cycle again. After 5 failures, the control waits 60 minutes, then tries again. • If priority timer times out, switch to next priority and start priority timer. • If demand satisfied, go to postpurge.
Blower OFF	<ul style="list-style-type: none"> • Demand satisfied (temperature reaches target temperature or limit setting). • Gas valve off. • Blower to ignition speed for postpurge. • Return to standby after purge.
Maintenance	<ul style="list-style-type: none"> • Display turns BLUE, toggling between graphic screen and maintenance screen (occurs if maintenance schedule timer times out). • Will show during standby only. • Boiler operates as normal.
Error/fault	<ul style="list-style-type: none"> • Display turns RED due to error or limit event. • Flashing display means lockout condition.
WWSD	<ul style="list-style-type: none"> • Warm weather shut down - the boiler will not be allowed to fire on space heating if the outside temperature is greater than the WWSD setting. • DHW operation is not affected by WWSD.



Evergreen control operation *(continued)*

EVG control Priorities & Input/Outputs

- For heating installations with multiple systems, the EVG control uses PRIORITIES to determine the order of operation of the systems. The control's MAX and MIN time settings determine the maximum and minimum times a system will be operated before being turned off to allow another system to operate. A typical example is DHW priority — heat demand from the DHW system is given preference over space heating, if set to use Priority 1.
- Each PRIORITY has its own set of operating parameters. The control prompts the user to select the system type (finned tube baseboard, DHW, etc.) and is factory programmed with parameters suited to each of these system types. The user can also choose CUSTOM to create a system type.
- The EVG control provides up to three priorities for single boiler applications and up to four priorities for network boiler applications. The order of operation is: PRIORITY 1, PRIORITY 2, PRIORITY 3.
- The 120VAC power output to the boiler circulator is provided by a terminal block located on the boiler's left cabinet wall. For each of the priorities, the control can be setup to run the boiler pump or to leave it off. It is recommended to set Blr Circ to OFF for DHW that is directly piped with its own DHW Circ.
- Each boiler has three input/output pairs (INPUT/OUTPUT 1, 2 and 3). Control setup prompts the user to assign each of these I/O pairs to a PRIORITY. The EVG control then knows which system (priority) to operate when the input receives a call for heat. On a call for heat to an input, the EVG control closes the corresponding output (120VAC) and begins controlling the boilers according to the setup for the assigned priority.
- The MAX ON TIME setting controls the maximum time a priority will be allowed to run before switching to a lower priority's call for heat. The MIN ON TIME setting controls the minimum time a priority will be operated before switching to a higher priority's call for heat, or the next lower priority.
- When multiple inputs are set up on the same priority, they will run at the same time if the priority and inputs are active.

Evergreen control operation

- The control responds to signals from:
 - Room thermostats.
 - DHW aquastats (if used).
 - Temperature sensors (boiler return, boiler supply, flue temperature) and, when used, system supply and system return, outdoor temperature). **For optimal performance, it is recommended to install the system supply and return sensors.**
- The control automatically adjusts blower speed (and gas flow rate) to match boiler output to space heating and/or DHW heating demand.
- The control provides three inputs and three outputs (for circulators or auxiliary devices) plus a fourth boiler circulator output.
- Outdoor reset must be used in all applications that are not exempt as described on page 139.
 - The outdoor temperature is used for supply temperature reset operation and for the warm weather shut down (WWSD) option.
- System presets:
 - The Evergreen control provides presets by system type (see Figure 71, page 78 for complete list).

Setting Up the Boiler	
Step 1	<ul style="list-style-type: none"> DETERMINE input/output needs – What are the inputs? – Thermostats, remote contacts, end switches, etc. What does each control's output need to do? – operate a pump, activate an air louver, etc.
Step 2	<ul style="list-style-type: none"> Connect wiring to the control inputs and outputs to accomplish the purposes set in Step 1.
Step 3	<ul style="list-style-type: none"> Install the boiler following all instructions in the Evergreen Boiler Manual before proceeding further. See the Advanced Manual for multiple boiler installations. Follow instructions in the Boiler Manual to start up and power the boiler.
Step 4	<ul style="list-style-type: none"> Use the WIZARD (below) or enter control parameters manually (skip Wizard).

Evergreen control WIZARD

- The Wizard is available on initial setup of the boiler. It leads through a step-by-step setup procedure designed for the application chosen.
- Context-sensitive help is available to explain the purpose of key setup items.
- Advanced settings for single boiler applications can be accessed manually from the Contractor menu.

WIZARD Sequence	
Boiler Settings	<ul style="list-style-type: none"> Altitude – ⚠WARNING – must be set correctly for proper operation. WWSD – set outdoor temperature above which space heating will be deactivated. Fuel (natural gas or propane) – ⚠WARNING – must be set correctly for proper operation – control will pause until this value is selected.
Inputs/Outputs	<ul style="list-style-type: none"> Select the usage of inputs 1, 2 and 3. Determine usage of outputs 1, 2 and 3 (outputs correspond to inputs).
Set Priorities	<ul style="list-style-type: none"> Assign priorities 1, 2 and 3 to the inputs.
System Settings	<ul style="list-style-type: none"> Set system settings or leave at their defaults.
System Types	<ul style="list-style-type: none"> Specify what system type is connected to each of the three outputs; each system type causes the control to preset operating temperatures.
Output Activation	<ul style="list-style-type: none"> (When applicable) Select when to activate AUX PUMP/OUTPUT – by input, always on, external switch, etc.
Priority Switching	<ul style="list-style-type: none"> Set maximum and minimum timings for priorities.
Date/Time	<ul style="list-style-type: none"> Set date and time – important for control diagnostic logging.
Information	<ul style="list-style-type: none"> Set installer name and contact information. Enter CP#, install date, maintenance date, etc. Set automatic maintenance notification timing.



Evergreen control operation *(continued)*

Outdoor reset operation

1. Set desired temperatures for space heating zones.
2. For an explanation of the target temperatures and associated outdoor temperatures, see Figure 66.
3. The temperature settings discussed below are accessed in the priority menu for the applicable system. For detailed explanations of the priority menus, see Figure 74, page 81.

SUPPLY MAX

1. Set Supply max to the required supply water temperature for the system at design maximum heat loss (typically 180°F for finned tube baseboard on new installations).

SUPPLY MIN

1. Supply Min should equal the desired minimum supply water temperature for the system.
2. This could be set as low as 70°F, which would supply “zero heat” when outdoor temperature is 70°F, because supply water temperature would equal room temperature.
3. See examples in Figure 66.

OD RESET MAX

1. OD RESET MAX means the outdoor temperature at which the target temperature reaches its minimum (Supply Min).
2. In the examples of Figure 66, this occurs at 70 °F (the factory default).

OD RESET MIN

1. OD RESET MIN means the outdoor temperature at which the target temperature reaches its maximum value (Supply max).
2. In the examples of Figure 66, this occurs at 0°F outside (the factory default setting).
3. OD RESET MIN should equal the ODT (outdoor design temperature) for the installation’s location.

Remote target operation (0–10VDC input)

1. This function allows a remote analog input to regulate the supply temperature for control operation/modulation. This can be done for any priority, including network and local priorities for multiple boiler networks.
2. The settings discussed below are accessed in the priority menu for the applicable system. For detailed explanations of the priority menus, see Figure 74, page 81.
3. See Figure 67 for an explanation of target temperature vs voltage when using remote target operation.
4. In the priority menu for the applicable system, select 0-10V for the TARGET ADJUST setting.
5. In the same priority menu, select the VOLTS FOR MIN and VOLTS FOR MAX values. VOLTS FOR MIN sets the voltage value for the desired minimum supply temperature. VOLTS FOR MAX sets the voltage value for the desired maximum supply temperature.

Figure 66 Outdoor reset operation

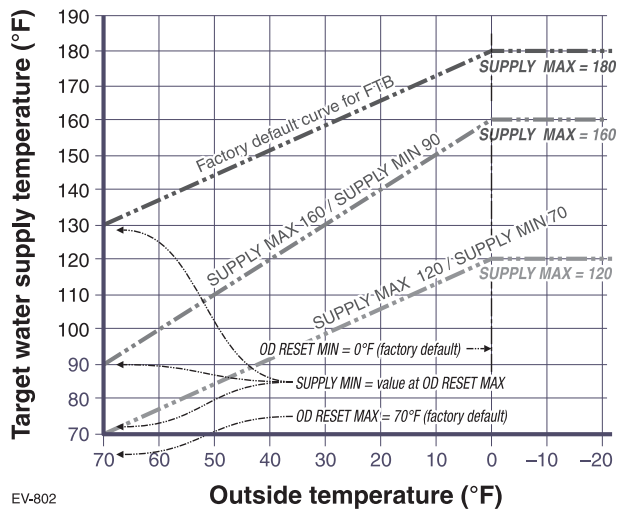

EV-802

Figure 67 Remote target operation

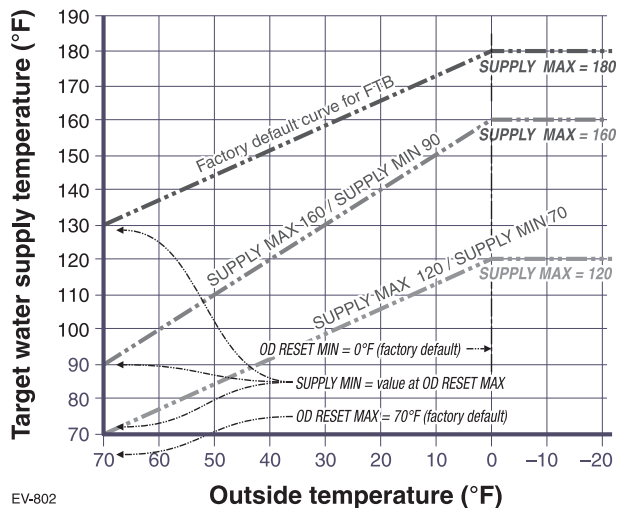

EV-802

Remote modulation operation (0–10VDC input)

1. To use 0-10VDC for remote modulation, go to Contractor Menu -> Assign Inputs. Then change Input 1’s source to 0-10V. The priority that is assigned to Input 1 cannot be used by any other Input.
2. The boiler comes on at 0.9VDC and turns off at 0.8VDC. 2 VDC = 20% input. 10VDC = 100% input. These voltage settings are not adjustable.



Evergreen control operation *(continued)*

Figure 68 Evergreen single boiler essential settings (REQUIRED on initial start-up) — see page 78 for explanation

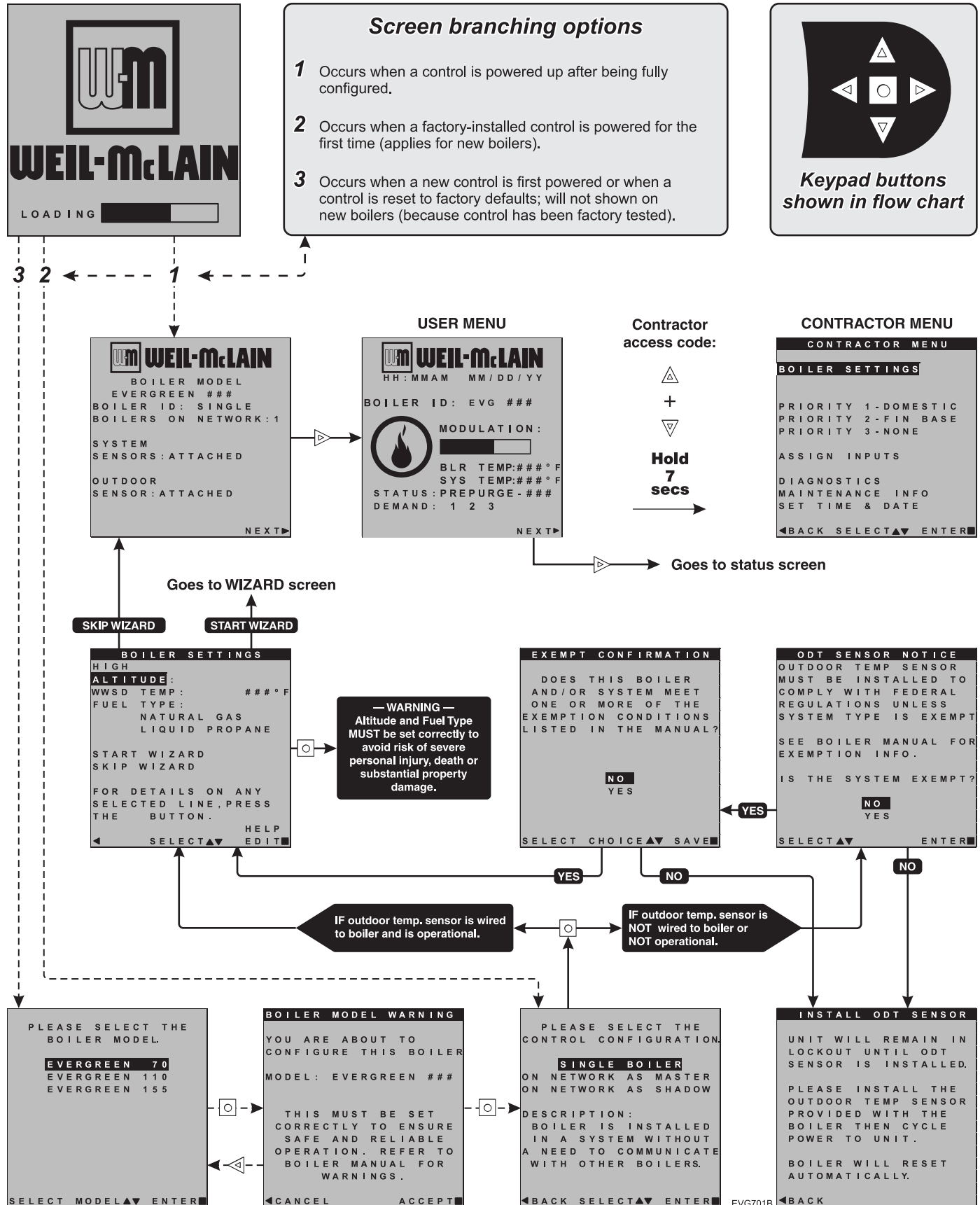



EVG control settings menus

Figure 69 Evergreen® control display screens and typical navigation

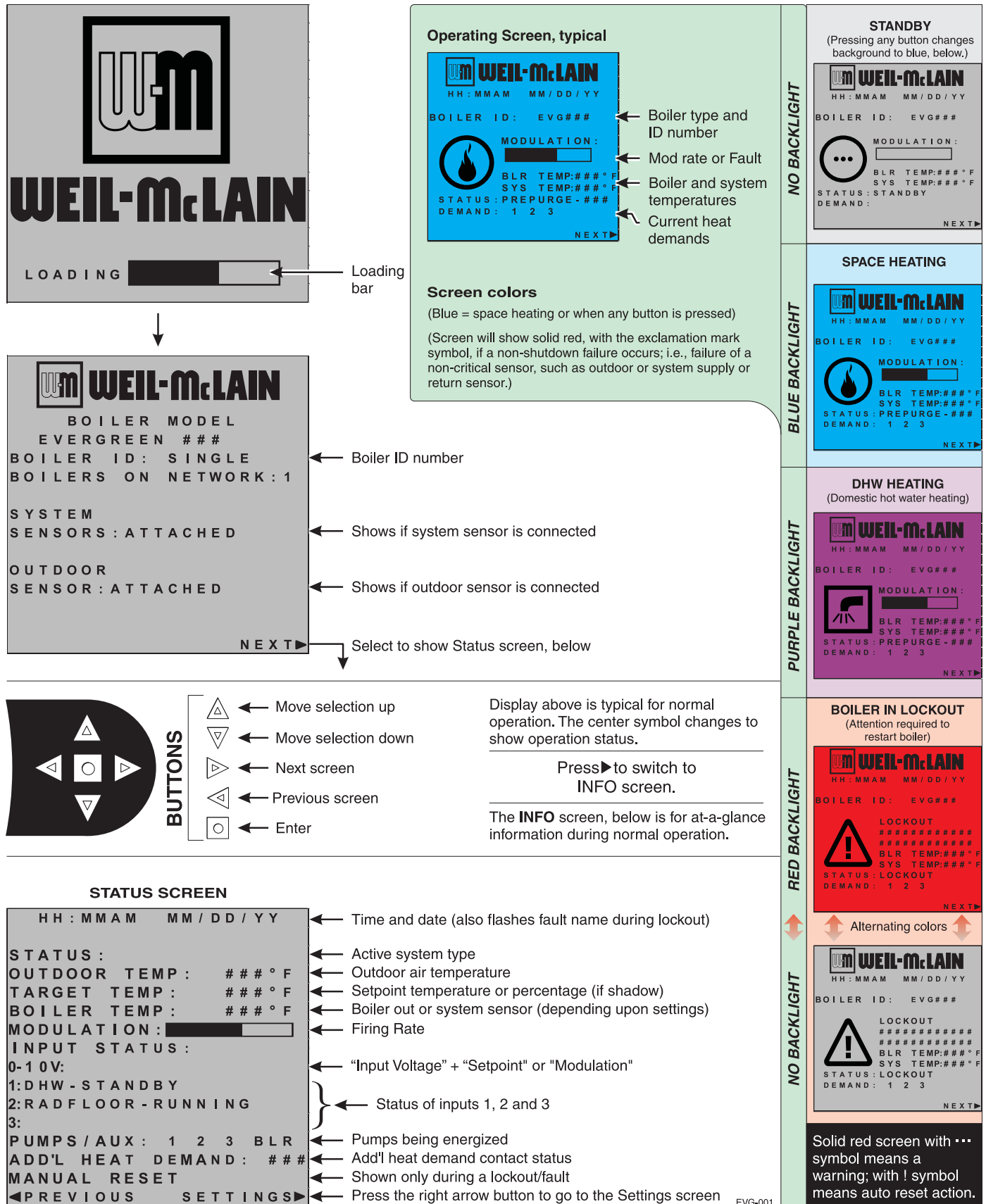



EXPRESS SETUP — Example A

Multi-zone **SPACE HEATING** (Circulators with circulator relays) | **DHW** (Direct-piped)

⚠ WARNING

Boiler Model, Altitude and Fuel Type are critical settings. Failure to set correctly could result in severe personal injury, death or substantial property damage.

Incorrect setup or piping can result in severe personal injury, death or substantial property damage.

Use primary/secondary piping or equivalent unless system meets requirements on page 43.

Verify that the correct system type is selected on the control and that operating temperature settings are suitable for the system. System and structural damage can occur if temperatures are too high.

Purpose

- Space heating with multiple zones.
- Zoning with circulators using circulator relays.
- DHW piped directly to the boiler.
- DHW priority — space heating is disabled during call for heat from water heater.

Control setting notes

- See the table at right for required and optional settings.
- The sequence in the table follows the WIZARD.
- If not using the WIZARD, follow instructions elsewhere in this manual to enter the settings manually.

Circulators and piping

⚠ WARNING

Provide an external relay and external power to any circulator if its load rating exceeds 2.2 amps FLA, 3.6 amps locked rotor, or 16.4 amps in rush.

- Piping must be primary/secondary as shown.
- DHW circulator must be selected to handle the pressure drop through the boiler, water heater and piping. DHW circulator supplied by installer.
- For some large indirect water heaters, the required flow rate may require piping the water heater differently.
- The control settings in table at right provide DHW priority — space heating will be discontinued during a call for DHW.
- Zone circulators and relays supplied by installer. For alternate zone wiring using a zone controller, see page 65.

BOILER

- Boiler circulator shipped loose with boiler.
- Follow all instructions in this manual for piping boiler and system.

EVG CONTROL SETTINGS (IN ORDER OF WIZARD SEQUENCES)		RED — VALUE MUST BE SET OR VERIFIED D — DEFAULT ACCEPTABLE; CHANGE ONLY IF DESIRED
BOILER SETTINGS		
BOILER MODEL	Verify model number is correct	
WWSO TEMP	Default (70 °F) or as required	
HIGH ALTITUDE	Set to YES if above 5,500 feet	
INPUT/OUTPUT 1 (Assign to PRIORITY 1)		
WHAT IS THE USE OF INPUT/OUTPUT 1?	HEAT/DHW DEMAND	
WHAT PRIORITY IS INPUT #1?	select PRIORITY 1	
WHAT SYSTEM TYPE IS INPUT/OUTPUT 1?	DHW (D)	
TARGET MOD SENSOR	BOILER OUT (D)	
TARGET ADJUST	NONE (D)	
SUPPLY MAX	D (or change if desired)	
RUN BOILER PUMP?	NO (D)	
RUN AUX PUMP/OUTPUT?	D (not applicable)	
INPUT/OUTPUT 2 (Assign to PRIORITY 2)		
WHAT IS THE USE OF INPUT/OUTPUT 2?	HEAT/DHW DEMAND	
WHAT PRIORITY IS INPUT #2?	PRIORITY 2	
WHAT SYSTEM TYPE IS INPUT/OUTPUT 2?	Select correct system type	
TARGET MOD SENSOR	SYSTEM SUPPLY (D)	
TARGET ADJUST	ODT (D) (Outdoor sensor must be installed)	
SUPPLY MAX	D (or change if desired)	
SUPPLY MIN	D (or change if desired)	
OD RESET MAX	D (or change if desired)	
OD RESET MIN	D (or change if desired)	
BOOST TIME	D (or change if desired)	
RUN BOILER PUMP?	YES (D)	
RUN AUX PUMP/OUTPUT?	D (not applicable)	
INPUT/OUTPUT 3 (Not used)		
WHAT IS THE USE OF INPUT/OUTPUT 3?	NONE	
PRIORITY SWITCH TIMES:		
P1 MAX ON TIME	D (or change if desired)	
P2 MAX ON TIME	D (or change if desired)	
P2 MIN ON TIME	D (or change if desired)	
P3 MIN ON TIME	D (not applicable)	
Finish the WIZARD		
ENTER TIME, DATE AND MAINTENANCE INFORMATION AS PROMPTED		

Note 1: If DHW is not used, set the USE of INPUT/OUTPUT 1 to NONE. Keep all other wiring as shown at right and follow all settings given above for PRIORITY 2.



EXPRESS SETUP — Example A (continued)

Multi-zone **SPACE HEATING** (Circulators with circulator relays) | **DHW** (Direct-piped)

PIPING

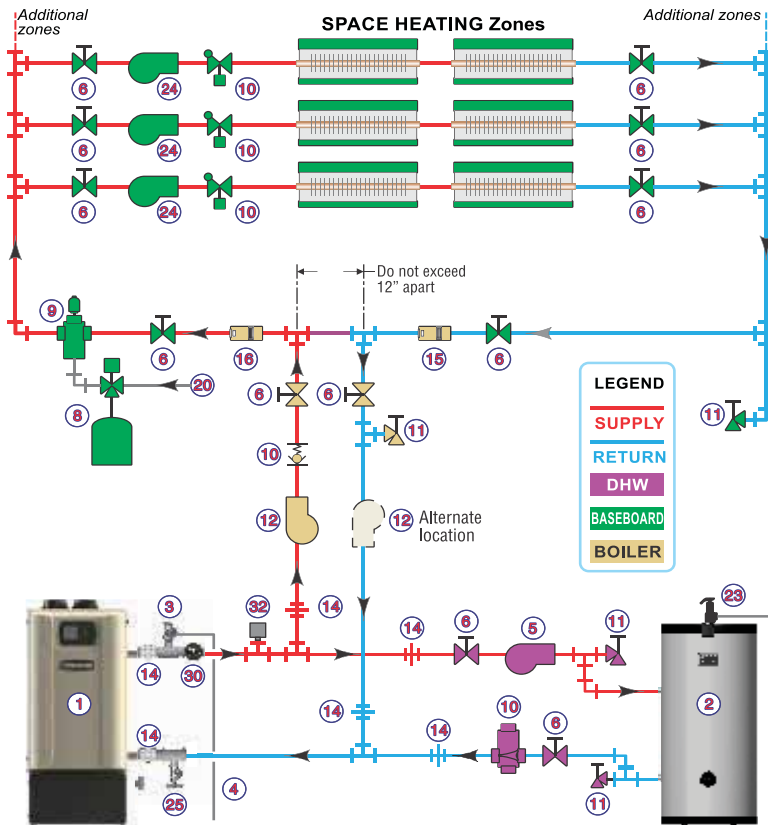

LEGEND

- | | |
|--|---|
| <ul style="list-style-type: none"> 1 ■ Evergreen boiler. 2 Indirect water heater, if used (domestic water piping not shown) — MUST be direct piped to boiler to use default control settings. 3 ■ Relief valve, supplied with boiler, field piped — MUST be piped to boiler supply connection — see Figure 8, page 14 for information. 4 Relief valve piping to drain. 5 DHW circulator. 6 Isolation valves. 8 Expansion tank. 9 Air separator. 10 Flow/check or spring check valves. 11 Purge/drain valves. 12 ■ Boiler circulator, supplied with boiler, field piped. | <ul style="list-style-type: none"> 14 Unions as needed for service. 15 Return temperature sensor. 16 Supply temperature sensor. 20 Make-up water supply. 23 DHW Temperature and Pressure relief valve 24 Zone circulators. 25 ■ Boiler drain valve, supplied with boiler, field piped. 30 ■ Pressure/temperature gauge, supplied with boiler, field piped. 31 Outdoor sensor. 32 Low water cut-off. 33 120VAC power to boiler — see page 57. 35 EVG Control module. |
|--|---|
- = Items supplied with boiler — all other items supplied by installer.

FIELD WIRING

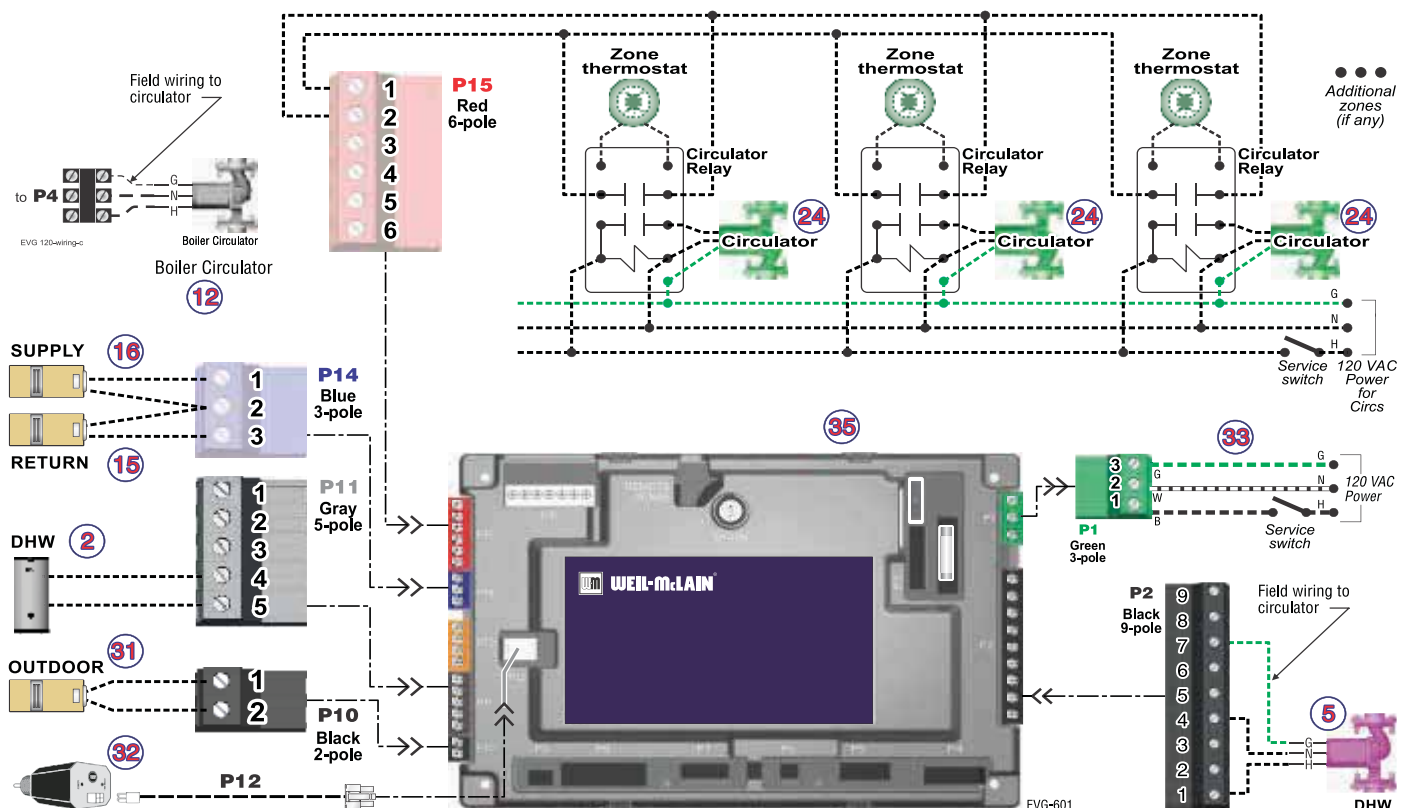



EXPRESS SETUP — Example B

2- or 3- Zone **SPACE HEATING** (Circulators without circulator relays) | **DHW** (Direct-piped)

⚠ WARNING

Boiler Model, Altitude and Fuel Type are critical settings. Failure to set correctly could result in severe personal injury, death or substantial property damage.

Incorrect setup or piping can result in severe personal injury, death or substantial property damage.

Use primary/secondary piping or equivalent unless system meets requirements on page 43.

Verify that the correct system type is selected on the control and that operating temperature settings are suitable for the system. System and structural damage can occur if temperatures are too high.

Purpose

- Space heating with multiple zones.
- Zoning with circulators using EVG control outputs to operate zone circulators (3 zones if space heating only; or 2 space heating zones plus DHW).
- DHW piped directly to the boiler.
- DHW priority — space heating is disabled during call for heat from water heater.

Control setting notes

- See the table at right for required and optional settings.
- The sequence in the table follows the WIZARD.
- If not using the WIZARD, follow instructions elsewhere in this manual to enter the settings manually.

Circulators and piping

⚠ WARNING

Provide an external relay and external power to any circulator if its load rating exceeds 2.2 amps FLA, 3.6 amps locked rotor, or 16.4 amps in rush.

- Piping must be primary/secondary as shown.
- DHW circulator must be selected to handle the pressure drop through the boiler, water heater and piping. DHW circulator supplied by installer.
- For some large indirect water heaters, the required flow rate may require piping the water heater differently.
- The control settings in table at right provide DHW priority — space heating will be discontinued during a call for DHW.
- Zone circulators supplied by installer. For alternate zone wiring using a zone controller, see page 66.

BOILER

- Boiler circulator shipped loose with boiler.
- Follow all instructions in this manual for piping boiler and system.

EVG CONTROL SETTINGS (IN ORDER OF WIZARD SEQUENCES)		RED — VALUE MUST BE SET OR VERIFIED D — DEFAULT ACCEPTABLE; CHANGE ONLY IF DESIRED
BOILER SETTINGS		
BOILER MODEL	Verify model number is correct	
WWSD TEMP	Default (70 °F) or as required	
HIGH ALTITUDE	Set to YES if above 5,500 feet	
INPUT/OUTPUT 1 (Assign to PRIORITY 1) (Note 1)		
WHAT IS THE USE OF INPUT/OUTPUT 1?	HEAT/DHW DEMAND	
WHAT PRIORITY IS INPUT #1?	select PRIORITY 1	
WHAT SYSTEM TYPE IS INPUT/OUTPUT 1?	DHW (D)	
TARGET MOD SENSOR	BOILER OUT (D)	
TARGET ADJUST	NONE (D)	
SUPPLY MAX	D (or change if desired)	
RUN BOILER PUMP?	NO (D)	
RUN AUX PUMP/OUTPUT?	D (not applicable)	
INPUT/OUTPUT 2 (Assign to PRIORITY 2)		
WHAT IS THE USE OF INPUT/OUTPUT 2?	HEAT/DHW DEMAND	
WHAT PRIORITY IS INPUT #2?	PRIORITY 2	
WHAT SYSTEM TYPE IS INPUT/OUTPUT 2?	Select correct system type	
TARGET MOD SENSOR	SYSTEM SUPPLY (D)	
TARGET ADJUST	ODT (D) (Outdoor sensor must be installed)	
SUPPLY MAX	D (or change if desired)	
SUPPLY MIN	D (or change if desired)	
OD RESET MAX	D (or change if desired)	
OD RESET MIN	D (or change if desired)	
BOOST TIME	D (or change if desired)	
RUN BOILER PUMP?	YES (D)	
RUN AUX PUMP/OUTPUT?	D (not applicable)	
INPUT/OUTPUT 3 (Assign to PRIORITY 2)		
If PRIORITY 2 is assigned, no further steps are required. If PRIORITY 3 is assigned, repeat the steps from INPUT/OUTPUT 2, above.		
PRIORITY SWITCH TIMES:		
P1 MAX ON TIME	D (or change if desired)	
P2 MAX ON TIME	D (or change if desired)	
P2 MIN ON TIME	D (or change if desired)	
P3 MIN ON TIME	D (not applicable)	
Finish the WIZARD		
ENTER TIME, DATE AND MAINTENANCE INFORMATION AS PROMPTED		

Note 1: If DHW is not used, provide a third space heating zone by setting up INPUT/OUTPUT 1 exactly the same as INPUT/OUTPUT 2. Make sure to assign INPUT/OUTPUT 1 to PRIORITY 2. This is because PRIORITY 2 is factory preset for space heating configurations. Wire the third zone thermostat to P11–4&5 and its circulator to P9–1,4&5.



EXPRESS SETUP — EXAMPLE B *(continued)*

2- or 3- Zone **SPACE HEATING** (Circulators without circulator relays) | **DHW** (Direct-piped)

PIPING

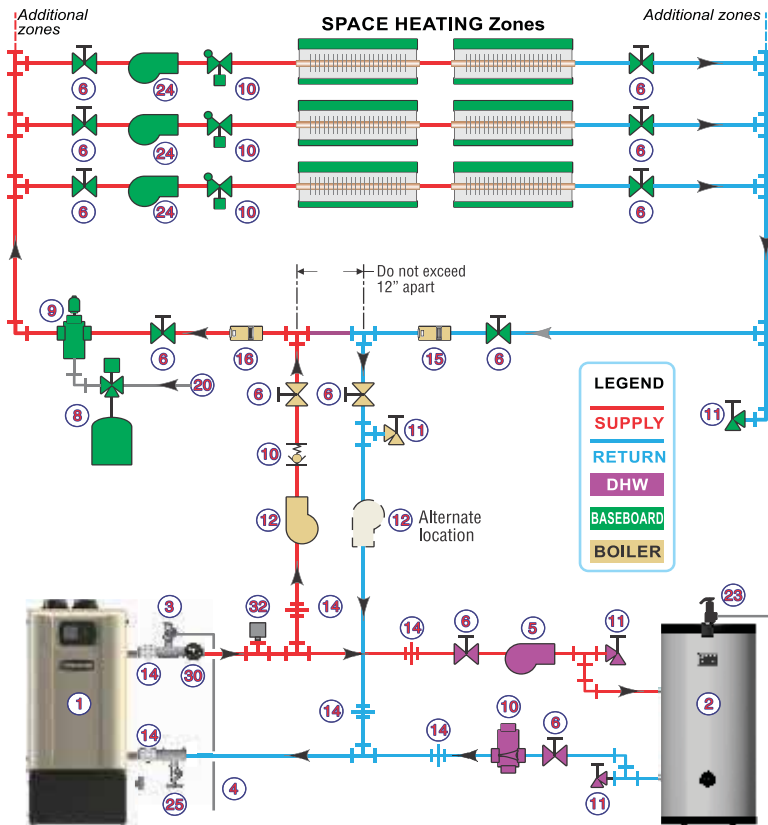

LEGEND

- | | |
|--|---|
| <ul style="list-style-type: none"> 1 ■ Evergreen boiler. 2 Indirect water heater, if used (domestic water piping not shown) — MUST be direct piped to boiler to use default control settings. 3 ■ Relief valve, supplied with boiler, field piped — MUST be piped to boiler supply connection — see Figure 8, page 14 for information. 4 Relief valve piping to drain. 5 DHW circulator. 6 Isolation valves. 8 Expansion tank. 9 Air separator. 10 Flow/check or spring check valves. 11 Purge/drain valves. 12 ■ Boiler circulator, supplied with boiler, field piped. | <ul style="list-style-type: none"> 14 Unions as needed for service. 15 Return temperature sensor. 16 Supply temperature sensor. 20 Make-up water supply. 23 DHW Temperature and Pressure relief valve 24 Zone circulators. 25 ■ Boiler drain valve, supplied with boiler, field piped. 30 ■ Pressure/temperature gauge, supplied with boiler, field piped. 31 Outdoor sensor. 32 Low water cut-off. 33 120VAC power to boiler — see page 57. 35 EVG Control module. |
|--|---|
- = Items supplied with boiler — all other items supplied by installer.

FIELD WIRING

ZONE THERMOSTATS

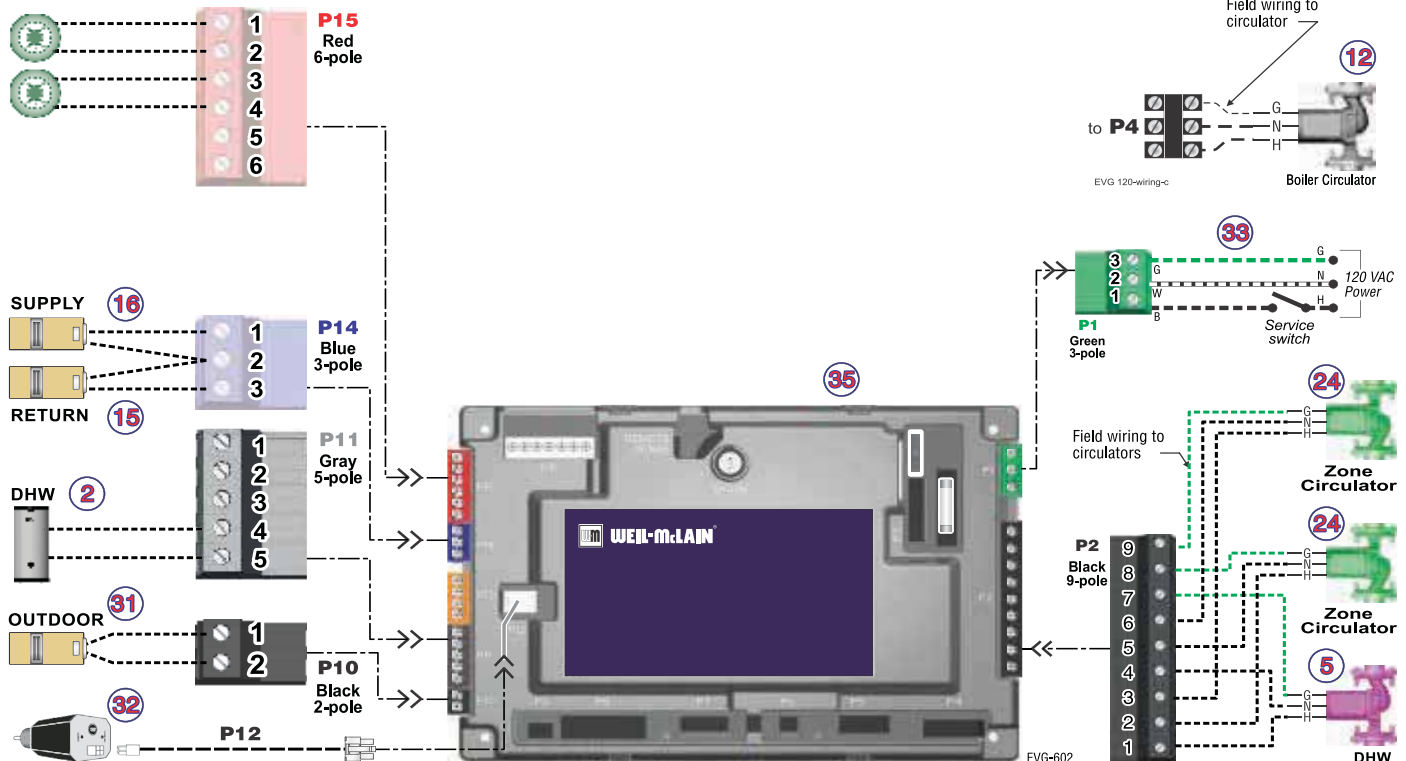



EXPRESS SETUP — Example C

Multi-zone **SPACE HEATING** (Zone valves + WMZV controller) | **DHW** (Direct-piped)

⚠ WARNING

Boiler Model, Altitude and Fuel Type are critical settings. Failure to set correctly could result in severe personal injury, death or substantial property damage.

Incorrect setup or piping can result in severe personal injury, death or substantial property damage.

Use primary/secondary piping or equivalent unless system meets requirements on page 43.

Verify that the correct system type is selected on the control and that operating temperature settings are suitable for the system. System and structural damage can occur if temperatures are too high.

Purpose

- Space heating with multiple zones.
- Zoning with zone valves. **DO NOT** use 3-wire zone valves — the voltage on the valve end switch will damage the EVG control. Use only 4-wire zone valves with isolated end switches.
- DHW piped directly to the boiler.
- DHW priority — space heating is disabled during call for heat from water heater.

Control setting notes

- See the table at right for required and optional settings.
- The sequence in the table follows the WIZARD.
- If not using the WIZARD, follow instructions elsewhere in this manual to enter the settings manually.
- The system circulator is wired to OUTPUT 2. It will be activated on any call for heat from a zone valve end switch.

Circulators and piping

⚠ WARNING

Provide an external relay and external power to any circulator if its load rating exceeds 2.2 amps FLA, 3.6 amps locked rotor, or 16.4 amps in rush.

- Piping must be primary/secondary as shown.
- DHW circulator must be selected to handle the pressure drop through the boiler, water heater and piping. DHW circulator supplied by installer.
- For some large indirect water heaters, the required flow rate may require piping the water heater differently.
- The control settings in table at right provide DHW priority — space heating will be discontinued during a call for DHW.
- Zone valves and system circulator supplied by installer. For alternate zone wiring using a zone controller, see page 66.
- A by-pass pressure regulator is recommended when used in a zone valve system as shown in this express setup.

BOILER

- Boiler circulator shipped loose with boiler.
- Follow all instructions in this manual for piping boiler and system.

EVG CONTROL SETTINGS (IN ORDER OF WIZARD SEQUENCES)

RED — VALUE MUST BE SET OR VERIFIED
D — DEFAULT ACCEPTABLE; CHANGE ONLY IF DESIRED

BOILER SETTINGS	
BOILER MODEL	Verify model number is correct
WWSO TEMP	Default (70 °F) or as required
HIGH ALTITUDE	Set to YES if above 5,500 feet
INPUT/OUTPUT 1 (Assign to PRIORITY 1)	
WHAT IS THE USE OF INPUT/OUTPUT 1?	HEAT/DHW DEMAND
WHAT PRIORITY IS INPUT #1?	select PRIORITY 1
WHAT SYSTEM TYPE IS INPUT/OUTPUT 1?	DHW (D)
TARGET MOD SENSOR	BOILER OUT (D)
TARGET ADJUST	NONE (D)
SUPPLY MAX	D (or change if desired)
RUN BOILER PUMP?	NO (D)
RUN AUX PUMP/OUTPUT?	D (not applicable)
INPUT/OUTPUT 2 (Assign to PRIORITY 2)	
WHAT IS THE USE OF INPUT/OUTPUT 2?	HEAT/DHW DEMAND
WHAT PRIORITY IS INPUT #2?	PRIORITY 2
WHAT SYSTEM TYPE IS INPUT/OUTPUT 2?	Select correct system type
TARGET MOD SENSOR	SYSTEM SUPPLY (D)
TARGET ADJUST	ODT (D) (Outdoor sensor must be installed)
SUPPLY MAX	D (or change if desired)
SUPPLY MIN	D (or change if desired)
OD RESET MAX	D (or change if desired)
OD RESET MIN	D (or change if desired)
BOOST TIME	D (or change if desired)
RUN BOILER PUMP?	YES (D)
RUN AUX PUMP/OUTPUT?	D (not applicable)
INPUT/OUTPUT 3 (Not used)	
WHAT IS THE USE OF INPUT/OUTPUT 3?	NONE
PRIORITY SWITCH TIMES:	
P1 MAX ON TIME	D (or change if desired)
P2 MAX ON TIME	D (or change if desired)
P2 MIN ON TIME	D (or change if desired)
P3 MIN ON TIME	D (not applicable)
Finish the WIZARD	
ENTER TIME, DATE AND MAINTENANCE INFORMATION AS PROMPTED	

Note 1: If DHW is not used, set the USE of INPUT/OUTPUT 1 to NONE. Keep all other wiring as shown at right and follow all settings given above for PRIORITY 2.



EXPRESS SETUP — EXAMPLE C (CONTINUED)

Multi-zone **SPACE HEATING** (Zone valves + WMZV controller) | **DHW** (Direct-piped)

PIPING

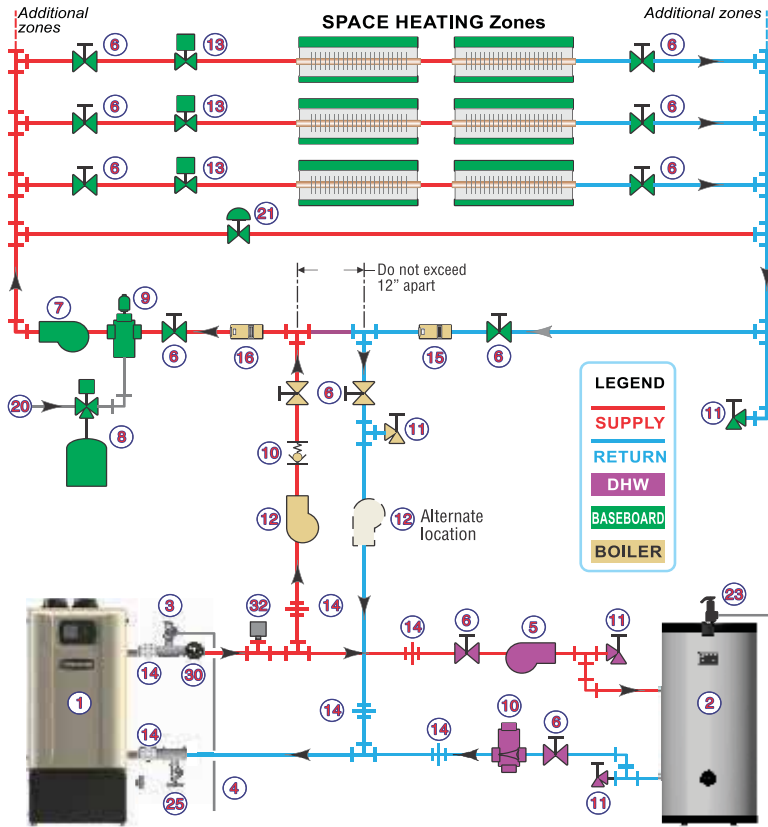

LEGEND

- Evergreen boiler.
 - Indirect water heater, if used (domestic water piping not shown) — **MUST be direct piped to boiler to use default control settings.**
 - Relief valve, supplied with boiler, field piped — **MUST be piped to boiler supply connection** — see Figure 8, page 14 for information.
 - Relief valve piping to drain.
 - DHW circulator.
 - Isolation valves.
 - System circulator.
 - Expansion tank.
 - Air separator.
 - Flow/check or spring check valves.
 - Purge/drain valves.
 - Boiler circulator, supplied with boiler, field piped.
 - Zone valves.
 - Unions as needed for service.
 - Return temperature sensor.
 - Supply temperature sensor.
 - Make-up water supply.
 - By-pass pressure regulator, **REQUIRED** for zone valve systems.
 - DHW Temperature and Pressure relief valve
 - Boiler drain valve, supplied with boiler, field piped.
 - Pressure/temperature gauge, supplied with boiler, field piped.
 - Outdoor sensor.
 - Low water cut-off.
 - 120VAC power to boiler — see page 57.
 - EVG Control module.
- = Items supplied with boiler — all other items supplied by installer.

FIELD WIRING

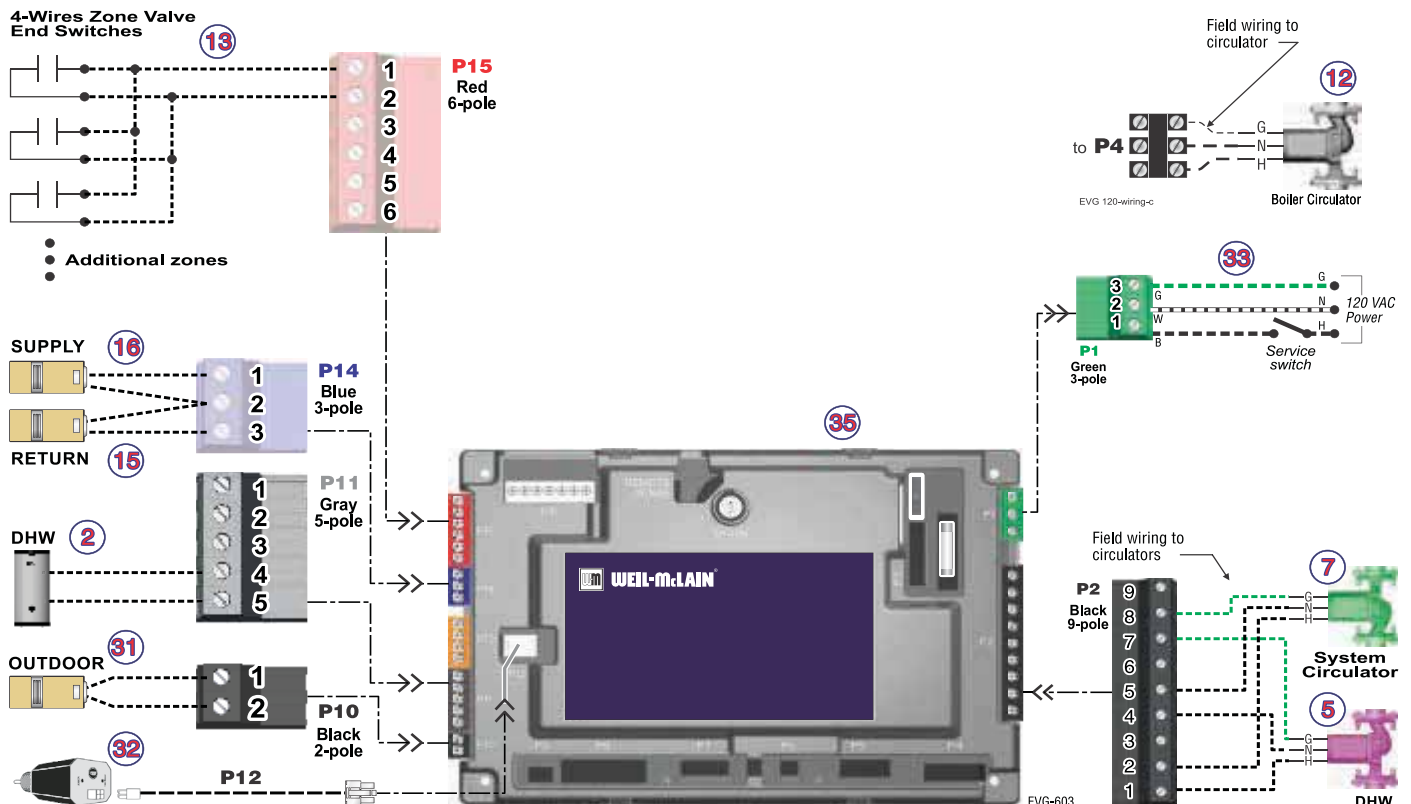



Available control settings and system presets

Figure 70 Evergreen control settings available in BASIC MODE (see Advanced Manual for ADVANCED MODE settings)

Available settings from CONTRACTOR MENU		
Boiler Settings Menu	Priority 2 menu	Assign Inputs menu
• Boiler Model	• Inputs Assigned (non-selectable)	Input 1: TT1
• Control Type	• System Type	• Priority 1, 2 or 3
• High Altitude	• Target Mod Sensor (non-selectable)	• Source (TT1 or 0-10V)
• LP Gas	• Target Adjust (non-selectable)	• AUX PUMP/OUTPUT
• ODT Sensor Exempt	• Supply Max	• Off
• Manual Reset High Limit Temp	• Supply Min (not available for DHW) *	
• WWSD Temp	• OD Reset Max (or Volts for Max) *	Input 2: TT2 and Input 3:TT3
• Adjust Outdoor	• OD Reset Min (or Volts for Min) *	• Priority 1, 2 or 3
• Circulator Exercising	• Boost Time *	• AUX PUMP/OUTPUT
• Freeze Protect Circs		• Off
• Reset Factory Default	Priority 3 menu	
	• Inputs Assigned (non-selectable)	Diagnostics menu
Priority 1 menu	• System Type	• See Figure 78, page 84 for details.
• Inputs Assigned (non-selectable)	• Target Mod Sensor (non-selectable)	
• System Type	• Target Adjust (non-selectable)	Maintenance Info menu
• Target Mod Sensor (non-selectable)	• Supply Max	• See Figure 83, page 89 for details.
• Target Adjust (non-selectable)	• Supply Min (not available for DHW) *	
• Supply Max	• OD Reset Max (or Volts for Max) *	Set Date and Time menu
• Supply Min (not available for DHW) *	• OD Reset Min (or Volts for Min) *	• See Figure 83, page 89 for details.
• OD Reset Max (or Volts for Max) *	• Boost Time *	
• OD Reset Min (or Volts for Min) *	* These items only appear in the menus if Target Adjust is active.	
• Boost Time *		

Figure 71 System types available in BASIC MODE (each option shown with factory settings)

System Type	8-Character Abbreviation	3-Character Abbreviation	Supply Max °F	OD Reset Min °F	Supply Min °F	OD Reset Max °F	Run Boiler Pump	Run AUX PUMP/OUTPUT
Fan-coil	FAN-COIL	FCL	180	0	140	70	YES	YES
Finned Tube Baseboard	FIN BASE	FTB	180	0	130	70	YES	YES
Cast Iron Baseboard	IRONBASE	CIB	180	0	120	70	YES	YES
Cast Iron Radiators	RADIATOR	CIR	180	0	120	70	YES	YES
Radiant - slab on grade	RAD SLAB	RSG	120	0	80	70	YES	YES
Radiant - thin slab	RAD SLAB	RTS	140	0	80	70	YES	YES
Radiant - below floor (staple up)	RADFLOOR	RSU	160	0	90	70	YES	YES
Radiant - above floor (sleeper system)	RADFLOOR	RAF	140	0	90	70	YES	YES
Domestic Hot Water	DOMESTIC	DHW	180	N/A	N/A	N/A	NO	NO
Custom (user defined)	XXXXXXXX (user input)	first three of user input	180	0	70	70	YES	YES



CONTRACTOR menus

⚠ WARNING Boiler Model, Altitude and Fuel Type are critical settings. Failure to set correctly could result in severe personal injury, death or substantial property damage.

1. Access contractor menus by pressing and holding the UP and DOWN arrow keys at the same time for 7 seconds.
2. See the following pages for explanations of control setting options.

Figure 72 Evergreen control menu access — accessing contractor menus

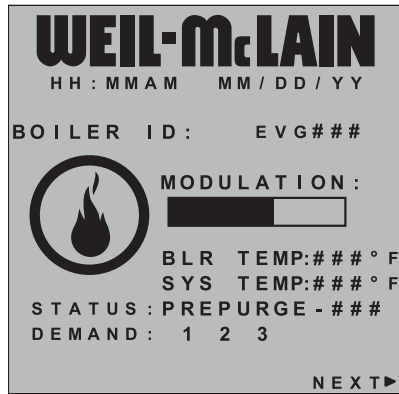

▲ + ▼ Hold 7 secs

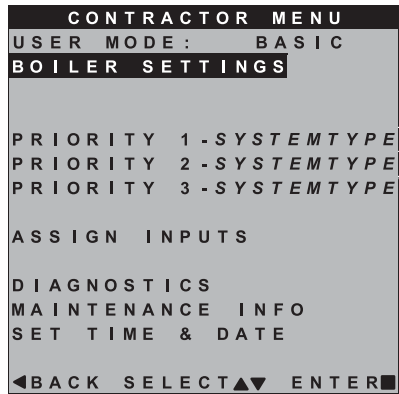

Highlight item, then press to select →

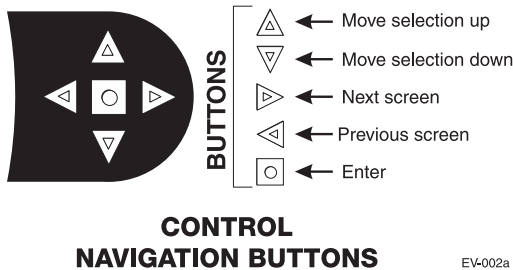

EV-002a

MENU ITEM	PURPOSE	More information
USER MODE	<ul style="list-style-type: none"> The default for this setting is BASIC mode. Screens shown in this manual assume the USER MODE is set to BASIC. For advanced features available in ADVANCED mode, see the Evergreen Advanced Manual. 	
BOILER SETTINGS	<ul style="list-style-type: none"> Set/change boiler model, control type, high altitude setting, ODT sensor requirement, manual reset, high limit and WWSD temperature settings, outdoor sensor temp adjustment, circulator exercising, freeze protection setup, and restore to factory default option. 	See page 80
PRIORITY 1	<ul style="list-style-type: none"> These settings control operating temperatures and behaviors for systems that are assigned to "PRIORITY 1." 	See page 81
PRIORITY 2	<ul style="list-style-type: none"> These settings control operating temperatures and behaviors for systems that are assigned to "PRIORITY 2." 	See page 81
PRIORITY 3	<ul style="list-style-type: none"> These settings control operating temperatures and behaviors for systems that are assigned to "PRIORITY 3." 	See page 81
ASSIGN INPUTS	<ul style="list-style-type: none"> These settings assign Priority 1, 2 or 3 to each of the three inputs to the Evergreen control. 	See page 82
DIAGNOSTICS	<ul style="list-style-type: none"> Use to review current and historical information including previous lockouts. 	See page 84
MAINTENANCE INFO	<ul style="list-style-type: none"> Used to set contractor contact information, boiler information and maintenance dates. 	See page 89
SET TIME & DATE	<ul style="list-style-type: none"> Use to set date and time — important since fault occurrences are date/time stamped. 	See page 89

Screens shown above are typical only. Actual screens depend on control settings chosen.



BOILER SETTINGS menu, BASIC mode

⚠ WARNING Boiler Model, Altitude and Fuel Type are critical settings. Failure to set correctly could result in severe personal injury, death or substantial property damage.

1. Access contractor menus by pressing and holding the UP and DOWN arrow keys at the same time for 7 seconds.
2. See Figure 72, page 79 for the screen sequences up to the CONTRACTOR menu.

Figure 73 Evergreen BASIC mode BOILER SETTINGS options (USER MODE must be set to BASIC)

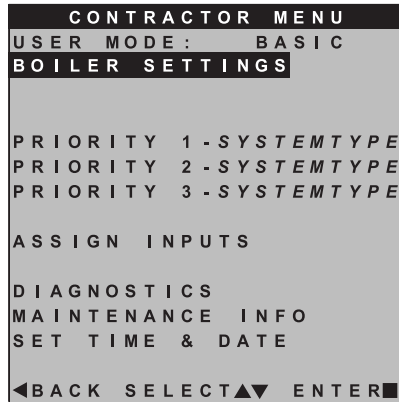

Highlight BOILER SETTINGS then press

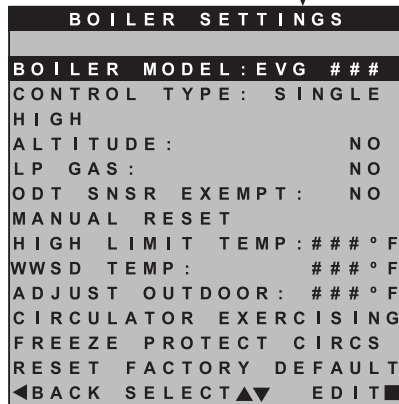

Highlight item, then press to select

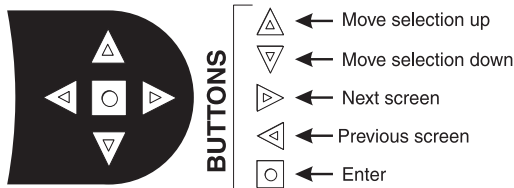

CONTROL NAVIGATION BUTTONS

EVG-002b

Screens shown above are typical only. Actual screens depend on control settings chosen.

MENU ITEM	DESCRIPTION
BOILER MODEL	<ul style="list-style-type: none"> • ⚠ WARNING MUST be set to correct model. • Check the boiler model against the model listed on the boiler's rating plate. Change the selection to the correct model if not. Also verify the model number on the Evergreen control display at power-up. Failure to correct would result in severe personal injury, death or substantial property damage.
CONTROL TYPE	<ul style="list-style-type: none"> • Select single, master or shadow. Must be set to Single for basic mode.
HIGH ALTITUDE	<ul style="list-style-type: none"> • ⚠ WARNING If the boiler is installed at an altitude above 5500 feet, select YES for high altitude. The control will automatically adjust firing rates (blower speeds) to compensate for altitude. Altitude MUST be set correctly to avoid risk of severe personal injury, death or substantial property damage.
LP GAS	<ul style="list-style-type: none"> • ⚠ WARNING MUST be correct — YES if LP Gas is used or NO if natural gas is used. Follow screen instructions to change if necessary.
ODT SENSOR EXEMPT	<ul style="list-style-type: none"> • Select YES only if boiler is exempt from the requirement for outdoor reset operation stipulated in Section 303 of the 2007 Energy Act. See information provided elsewhere in this manual.
MANUAL RESET HIGH LIMIT TEMP	<ul style="list-style-type: none"> • If boiler outlet water temperature exceeds this temperature, the Evergreen control will shut down the boiler and enter lockout. Changing this setting is NOT recommended.
WWSD TEMP	<ul style="list-style-type: none"> • WWSD stands for warm weather shut down. It means the boiler will not be allowed to fire if the outside temperature is greater than the WWSD setting. When the boiler is kept off because the outside temperature is above WWSD, the graphic display will show WWSD, and the boiler will remain in standby until the outside temperature drops below WWSD temperature. WWSD does not apply to DHW systems. The outdoor sensor must be installed to use this function.
ADJUST OUTDOOR	<ul style="list-style-type: none"> • Use this setting to calibrate the outdoor sensor when needed to compensate for variations in lead length or other factors that could affect total resistance in sensor circuit.
CIRCULATOR EXERCISING	<ul style="list-style-type: none"> • For each circulator, select whether you want the control to automatically start the circulator and run for 10 seconds for each 72-hour period of inactivity.
FREEZE PROTECT CIRCS	<ul style="list-style-type: none"> • This function automatically fires the boiler at low fire and starts the circulators chosen if the heat exchanger sensors detect a temperature less than 45 °F. Burner is turned on if temperature drops below 40 °F. Circulators and burner turn off when the temperature rises above 48 °F.
RESET FACTORY DEFAULTS	<ul style="list-style-type: none"> • Use this function to restore all control settings to factory default values — will require complete restart and setup of control after resetting. Record information from the MAINTENANCE screen and any history information that may be of use in the future. ALL stored data is eliminated when reset to defaults except for boiler model number.



PRIORITY 1, 2, 3 menus, BASIC mode

⚠ WARNING Boiler Model, Altitude and Fuel Type are critical settings. Failure to set correctly could result in severe personal injury, death or substantial property damage.

1. Access contractor menus by pressing and holding the UP and DOWN arrow keys at the same time for 7 seconds.
2. See Figure 72, page 79 for the screen sequences up to the CONTRACTOR menu.

Figure 74 Evergreen BASIC mode PRIORITY options (USER MODE must be set to BASIC)

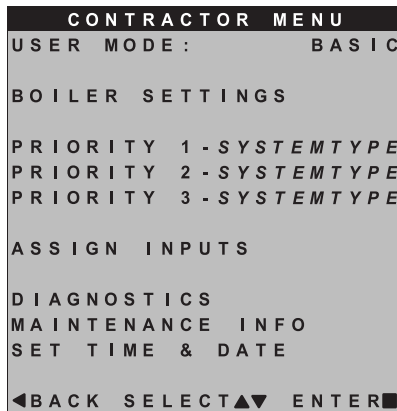

Highlight PRIORITY 1, 2 or 3 then press

1, 2 or 3

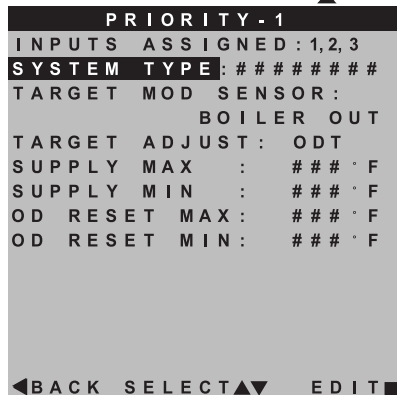

Highlight item, then press to select

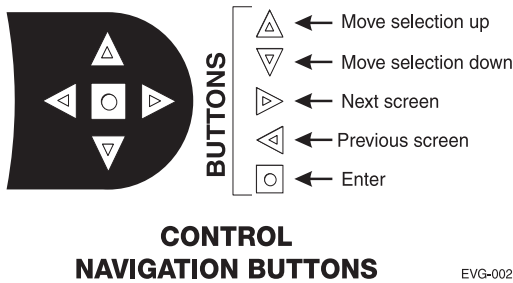

MENU ITEM	DESCRIPTION
INPUTS ASSIGNED	<ul style="list-style-type: none"> • Lists all the inputs already assigned to this PRIORITY. Inputs will be listed as 1, 2, 3. • Shows NONE if there are no inputs assigned to this priority .
SYSTEM TYPE	<ul style="list-style-type: none"> • Select the system type for this PRIORITY, based on the heating terminal units in the system (see Figure 71, page 78). Use the CUSTOM selection to set the control for a different system type. The factory preset values for SUPPLY MAX, SUPPLY MIN, OD RESET MAX and OD RESET MIN are chosen based on the normal best setting for the terminal units.
TARGET MOD SENSOR	<ul style="list-style-type: none"> • Choose SYSTEM SUPPLY or BOILER OUT to determine which will be the primary temperature sensor. The control will modulate boiler input to reach the TARGET temperature. (Default is System Supply.) If system sensors are not used, boiler defaults to using heat exchanger outlet sensor in place of system sensor. • Not adjustable in Basic Mode, see Advanced Manual for information on adjusting this parameter.
TARGET ADJUST	<ul style="list-style-type: none"> • Select how target temperature is calculated by control: NONE (no reset, fixed target temperature), 0-10V (target temperature based on analog input from remote source), ODT (outdoor reset operation; default setting). • Not adjustable in Basic Mode, see Advanced Manual for information on adjusting this parameter.
SUPPLY MAX	<ul style="list-style-type: none"> • Set SUPPLY MAX to the required supply water temperature for the system at design maximum heat loss (typically 180 °F for finned tube baseboard on new installations.)
SUPPLY MIN	<ul style="list-style-type: none"> • SUPPLY MIN should equal the desired minimum supply water temperature for the system. • This line is not shown on priorities configured as DHW system type or Heating system type, if outdoor temperature sensor not used. See Advanced Manual for information on adjusting this parameter .
OD RESET MAX (Not shown for Priority 1 by default)	<ul style="list-style-type: none"> • OD RESET MAX is the outdoor temperature at which the target temperature reaches its minimum (SUPPLY MIN). • This line is not shown on priorities configured as DHW system type or Heating system type, if outdoor temperature sensor not used. See Advanced Manual for information on adjusting this parameter .
OD RESET MIN	<ul style="list-style-type: none"> • OD RESET MIN means the outdoor temperature at which the target temperature reaches its maximum value (SUPPLY MAX). • OD RESET MIN should equal the ODT (outdoor design temperature) for the installation's location. • This line is not shown on priorities configured as DHW system type or Heating system type, if outdoor temperature sensor not used. See Advanced Manual for information on adjusting this parameter .

Screens shown above are typical only. Actual screens depend on control settings chosen.



ASSIGN INPUTS menu, BASIC mode

⚠WARNING Boiler Model, Altitude and Fuel Type are critical settings. Failure to set correctly could result in severe personal injury, death or substantial property damage.

1. Access contractor menus by pressing and holding the UP and DOWN arrow keys at the same time for 7 seconds.
2. See Figure 72, page 79 for the screen sequences up to the CONTRACTOR menu.

Figure 75 Evergreen BASIC mode ASSIGN INPUT options (USER MODE must be set to BASIC) — see Figure 76, page 83 and Figure 77, page 83 for explanation of AUX PUMP/OUTPUT settings

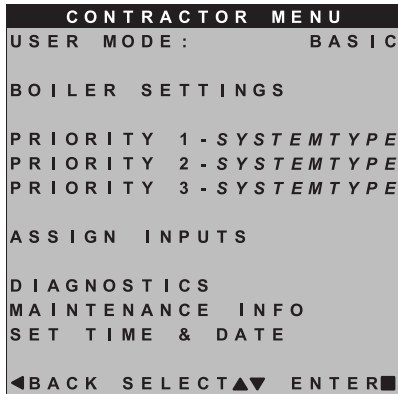

Highlight **ASSIGN INPUTS** then press

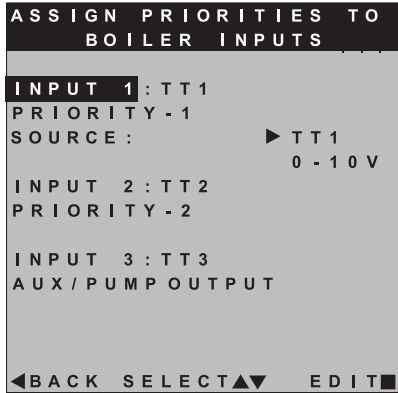

Highlight item, then press to select

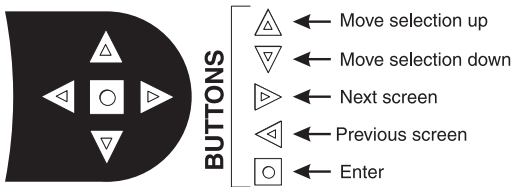

CONTROL NAVIGATION BUTTONS

EV-002db

MENU ITEM	DESCRIPTION
Overview	<ul style="list-style-type: none"> • There are three priority levels defined by the settings chosen in Figure 74, page 81. • For DHW priority, make sure PRIORITY 1 is defined for a DHW system. • If DHW priority is required and analog input (0-10V remote modulation) is used for space heating, wire the DHW aquastat to Input 2 (TT2) and assign INPUT 2 as PRIORITY 1 and INPUT 1 as PRIORITY 2 with SOURCE set to 0-10V.
INPUT 1	<ul style="list-style-type: none"> • Assign priority (system type) for INPUT 1 — options are: • PRIORITY 1 — assigns INPUT 1 to PRIORITY 1 system. • PRIORITY 2 — assigns INPUT 1 to PRIORITY 2 system • PRIORITY 3 — assigns INPUT 1 to PRIORITY 3 system • AUX PUMP/OUTPUT • OFF • NOTE: For INPUT 1 only, select SOURCE = TT1 for thermostat input or 0-10V if analog input is required.
INPUT 2	<ul style="list-style-type: none"> • Assign priority (system type) for INPUT 2 — options are: • PRIORITY 1 — assigns INPUT 2 to PRIORITY 1 system. • PRIORITY 2 — assigns INPUT 2 to PRIORITY 2 system • PRIORITY 3 — assigns INPUT 2 to PRIORITY 3 system • AUX PUMP/OUTPUT • OFF
INPUT 3	<ul style="list-style-type: none"> • Assign priority (system type) for INPUT 3 — options are: • PRIORITY 1 — assigns INPUT 3 to PRIORITY 1 system. • PRIORITY 2 — assigns INPUT 3 to PRIORITY 2 system • PRIORITY 3 — assigns INPUT 3 to PRIORITY 3 system • AUX PUMP/OUTPUT • OFF

Screens shown above are typical only. Actual screens depend on control settings chosen.



ASSIGN INPUTS menu, BASIC mode *(continued)*

Figure 76 AUX PUMP/OUTPUT operation (accessed in ASSIGN INPUTS menu – see Figure 75, page 82)

Option	Activation conditions	Suggested uses
ALWAYS ON	<ul style="list-style-type: none"> Output is always energized whenever the control is powered. 	<ul style="list-style-type: none"> Hot loop for seasonal boilers that are manually shut down at end of season and started up at start of heating season.
EXTERNAL SWITCH	<ul style="list-style-type: none"> The output is energized on closure of an external switch wired to this input and is de-energized when the external switch opens. 	<ul style="list-style-type: none"> Hot loop for boilers whose CH is manually shut down at end of season and started up at start of heating season, but remain available for local calls (DHW, etc.).
OUTDOOR BELOW WWSD	<ul style="list-style-type: none"> This output is energized only when outdoor temperature is below the WWSD setting (see BOILER SETTINGS menu, Figure 73, page 80). This setting is non-selectable if WWSD is set to OFF or ODT is not connected at initial boiler power. If Outdoor Below WWSD is already chosen and WWSD is later set to OFF, Outdoor Below WWSD will behave as Always On. 	<ul style="list-style-type: none"> Hot loop for boilers whose CH is automatically shut down based on outdoor temperature (inferred heat loss), but remain on for local calls (DHW, etc.).
ANY TT INPUT	<ul style="list-style-type: none"> The assigned output is energized if there is an input closure on this boiler. The assigned output will de-energize once there are; no input on this boiler, post-purge has finished and post-pump time has expired. If the closed input is configured for a heat demand, its output will de-energize after post-purge and post-pump. 	<ul style="list-style-type: none"> Energize a system pump relay if pump must run during all heating calls.
ANY TT INPUT BY ITS PRIORITY SETTINGS	<ul style="list-style-type: none"> The assigned output is energized: <ul style="list-style-type: none"> If there is an input closure on this boiler. ... and ... <ul style="list-style-type: none"> RUN AUX PUMP/OUTPUT is set to YES for the priority assigned to the closed input. The assigned output will de-energize once there are no input closures on any of the network boilers, post-purge has finished, and post-pump time has expired. 	<ul style="list-style-type: none"> Energize a system pump relay if pump must run only on some heat calls (such as systems with locally-connected DHW heating).
BURNER DEMAND	<ul style="list-style-type: none"> The assigned output is energized when the boiler receives a call for heat and starts to pre-purge. The assigned output is de-energized once the burner is off and post-purge is complete. 	<ul style="list-style-type: none"> Use for interlocking with combustion air damper, flow switch, etc.

Figure 77 AUX PUMP/OUTPUT operation — start, run and stop, based on boiler status

Option	Standby	TT Closed	Pre-Pump	Pre-Purge	Burner Running	Post-Purge	Post-Pump	Standby	Comments
ANY TT INPUT OR ANY TT INPUT BY ITS PRIORITY SETTINGS	off	ON	→					off	<ul style="list-style-type: none"> See Figure 76 for explanation of differences between the ANY TT INPUT options.
BURNER DEMAND	off	off	off	ON	→		off	off	



DIAGNOSTIC menu

Figure 78 DIAGNOSTICS menu navigation (see Figure 69, page 71 for access information)

Menus	Next screen	Next screen	Next screen	Next screen
<i>Follow information at the bottom of each screen to navigate to next/previous screen or enter/save data</i>				
DIAGNOSTICS	TEMPERATURES	STATUS: ##### BOILER OUT1: ## °F BOILER OUT2: ## °F BOILER IN: ## °F SYSTEM SUPPLY: ## °F SYSTEM RETURN: ## °F FROM SENSOR: ##### FLUE 1: ## °F FLUE 2: ## °F OUTDOOR TEMP: ## °F FROM SENSOR: #####		See following pages for details.
	INPUTS	STATUS: ##### INPUT1: ##### (8-character system type) INPUT2: ##### (8-character system type) INPUT3: ##### (8-character system type) 0-10V: #.# #V LINKED TO MASTER: ### DEMAND OF MASTER: ### MANUAL LIMIT: ##### AUTO LIMIT: ##### LOW WTR CUTOFF: ##### AIR P-SWITCH: ##### CLOSURE SWITCH: ##### BLOWER SPEED: ####RPM FLAME SIGNAL: ###		See following pages for details.
	OUTPUTS	STATUS: ##### GAS VALVE: ### CIRC OUTPUT 1: ### CIRC OUTPUT 2: ### CIRC OUTPUT 3: ### BOILER CIRC: ### BLOWER SIGNAL: ###% ADD'L HEAT DEMANDS: ### ALARM: ###		See following pages for details.
	RUNTIME	BURNER TIME: ##HR ROTATE TIME: ##DAYS INPUT1 TIME: ##HR INPUT2 TIME: ##HR INPUT3 TIME: ##HR NETWORK TIME: ##HR IGNITION COUNT: ###		See following pages for details.
	MASTER-SHADOW COMM (shows on shadow boilers only)	Boiler ID: ##### Linked to Master: ### Boilers on Network: # Requested to Run: ### Type: #####-## Requested Mod Rate: ### Max Boiler Temp: ## °F Boiler ON Diff: ## °F Boiler OFF Diff: ## °F		See following pages for details.
	NETWORK BOILERS (shows on master boilers only)	Shows firing rate, boiler temperature, active priority, with system type and sequence order of all boilers on the network.		See following pages for details.



DIAGNOSTICS menu *(continued)*

Figure 79 DIAGNOSTICS menu navigation, continued (see Figure 69, page 71 for access information)

Menus	Next screen	Next screen	Next screen	Next screen	
<i>Follow information at the bottom of each screen to navigate to next/previous screen or enter/save data</i>					
DIAGNOSTICS <i>(cont.)</i>	NETWORK INPUTS (shows on master boilers only)	Shows input status of all network boiler inputs.			
	SOFTWARE VERSIONS	DISPLAY WM#.# MAIN MICRO WM#.# SECOND MICRO WM#.#	See following pages for details.		
	PAST ERRORS	CONTROL FAULTS: ### IGNITION RETRIES: ###	See following pages for details.		
		MANUAL RESET CNT: ###	See following pages for details.		
		AUTO RESET CNT: ###	See following pages for details.		
		LOCKOUT HISTORY 1 LOCKOUT HISTORY 2 LOCKOUT HISTORY 3	LOCKOUT HISTORY # FAULT NAME: #### FAULT TYPE: #### TIME: HH:MM AM DATE: MM/DD/YY STATUS: ####### TEMPERATURES INPUTS OUTPUTS	TEMPERATURES INPUT STATUS OUTPUT STATUS	
MANUAL TEST MODE (Single boiler or network Shadow boiler)	STATUS: ####### INPUTS: #### TARGET: ### °F or “%” for network MODULATION: ####### BOILER OUT: ### °F BOILER IN: ### °F SYSTEM SUPPLY: ### °F SYSTEM RETURN: ### °F FLUE: ### °F OUTDOOR: ### °F BLOWER SIGNAL: ###% BLOWER SPEED: ###RPM FLAME SIGNAL: ### FORCE RATE: AUTO	See following pages for details.			
MANUAL RESET	PRESS ENTER TO RESET THE FOLLOWING ERROR (SCREEN SHOWS A LIST OF ERRORS)	See following pages for details.			



DIAGNOSTICS menu *(continued)*

Figure 80 DIAGNOSTICS menu details (see Figure 69, page 71 for access information)

Menu/Item	Comment
Temperatures	
Status	Current operating status of the boiler. Prepurge, Ignition, Name of the system Type being satisfied, post purge, Warm Weather Shut down, Trouble
Boiler Out1	Temperature of the first sensing element of the boiler's heat exchanger outlet sensor
Boiler Out2	Temperature of the second sensing element of the boiler's heat exchanger outlet sensor
Boiler In	Temperature of the boiler's heat exchanger inlet sensor
System Supply	Temperature of the system water after the boiler loop
System Return	Temperature of the system water returning to the boiler loop
From Sensor	Displays where System Supply/Return values are being read from. Most relevant when using multiple sensors connected to the same Master Boiler Network. When Shadow boilers are connected, this will specify which boiler it is reading.
Flue1	Temperature of the first sensing element of the boiler's flue gas sensor
Flue2	Temperature of the second sensing element of the boiler's flue gas sensor
Outdoor	Temperature of the remote outdoor air temperature sensor
Inputs	
Status	Current operating status of the boiler. Prepurge, Ignition, Name of the system Type being satisfied, post purge, Warm Weather Shut down, Trouble
Input 1	Call for heat status on Input 1 (Input 1 can be TT1 or 0-10VDC input)
Input 2	Call for heat status on Input 2
Input 3	Call for heat status on Input 3
0-10V	Voltage input for target adjust or modulation for single boiler
Linked to Master	For Multiple Boiler Networks. Shows if current control is connected to Master boiler
Demand of Master	For Multiple Boiler Networks. Shows if the Master boiler is calling this boiler heat demand
Manual Limit	External manual limit on low voltage terminal strip
Auto Limit	External auto limit on low voltage terminal strip
Low Wtr Cutoff	Low water cutoff device (inside boiler jacket)
Air P-Switch	Limit device (inside boiler jacket) that will shut off the boiler if flue pressure becomes too high
Closure Switch	P7 jumper circuit closed or open (flow switch, CAD, etc.)
Blower Speed	Feedback from blower sensor
Flame Signal	Number indicating the presence and quality of the flame used to shut down or boost the boiler
Outputs	
Status	Current operating status of the boiler. Prepurge, Ignition, Name of the system Type being satisfied, post purge, Warm Weather Shut down, Trouble
Gas Valve	Control's gas valve circuit status
Circulator 1	Control's circulator 1 relay status
Circulator 2	Control's circulator 2 relay status
Circulator 3	Control's circulator 3 relay status
Boiler Circ	Boiler's circulator
Blower Signal	Control's signal controlling the blower speed
Additional Heat Demand	Additional heat demand contact status
Alarm	Alarm contact status



DIAGNOSTICS menu *(continued)*

Figure 81 DIAGNOSTICS menu details (continued) (see Figure 69, page 71 for access information)

Menu/Item	Comment
Run Times	
Burner Time	Displays cumulative time the burner has been active (can be increased by user)
Rotate Time	Records the days of operation passed from the last time the Master boiler rotated the firing sequence.
Input 1 Time	Displays cumulative time that Input 1 has been closed (Or 0-10V ≥ 1 volt)
Input 2 Time	Displays cumulative time that Input 2 has been closed
Input 3 Time	Displays cumulative time that Input 3 has been closed
Network Time	Records time this boiler was running on a network call for heat generated by the Master boiler
Ignition Count	Displays total number of successful ignitions
Master-Shadow Comm	
Boiler ID	Displays boiler control type and ID number
Linked to Master	Shows if control is currently linked to a Master control
Boilers on Network	Shows number of boilers currently on network
Requested to Run	Shows if this control is being requested to satisfy a network call
Type	Shows whether the control is Network-P1, Network-P2, or NONE
Requested Mod Rate	Rate coming from the Master
Max Boiler Temp	Displays maximum allowable boiler temperature
Boiler On Diff	Temperature differential from master boiler for network priorities
Boiler Off Diff	Temperature differential from master boiler for network priorities
Network Boilers	
For multiple boilers only – See EVG Advanced manual	
###%	Shows current rate of boiler
###F	Shows Boiler Out temperature of boiler
#####	Shows priority being satisfied, updated based on active demand
#####	Shows system type of call for heat, updated based on active demand
# OF #	Shows the sequence position of that boiler in all the boilers available
BLR#	Shows boiler number this data belongs to
Network Inputs	
Boiler number	Displays boiler number
Inputs	Displays input's configuration and whether it is active. If input is active, it will be displayed in BOLD print
Software Versions	
Display	Software version of the microprocessor on the display circuit board
Main Micro	Software version of the main microprocessor on the control circuit board
Second Micro	Software version of the second microprocessor on the control circuit board
TO RESET ALL HISTORY COUNTERS TO ZERO:	To reset all history counters to zero: Enter the PAST ERRORS menu. Then press and hold the left and right arrows located below the control display. Hold for 5 seconds. This will cause ALL history to be deleted. To maintain history, reset counters individually.
Past Errors	
Control Fault	Displays number of control faults
Ignition Retries	Displays cumulative ignition attempts. It is recommended that his be reset during yearly maintenance by holding down the Left and Right arrows or by selecting this line and pressing the Enter button
Manual Reset Cnt	Displays number of manual reset lockouts since last cleared
Auto Reset Cnt	Displays number of auto reset lockouts since last cleared
Lockout History 1	Choose this to view the most recent error recorded
Fault Name	Displays the name of the fault that occurred



DIAGNOSTICS menu *(continued)*

Figure 82 DIAGNOSTICS menu details (continued) (see Figure 69, page 71 for access information)

Menu/Item	Comment
Fault Type	Displays the type of fault that occurred
Time	Displays time that lockout occurred
Date	Displays date that lockout occurred
Status	Displays what the status of the boiler was at the time of the error
Temperatures	Choose this to view the Boiler Temperatures at the time of the error
Inputs	Choose this to view the status of the Boiler Inputs at the time of the error
Outputs	Choose this to view the status of the Boiler Outputs at the time of the error
Lockout History 2	Choose this to view the second most recent error recorded
Fault Name	Displays the name of the fault that occurred
Fault Type	Displays the type of fault that occurred
Time	Displays time that lockout occurred
Date	Displays date that lockout occurred
Status	Displays what the status of the boiler was at the time of the error
Temperatures	Choose this to view the Boiler Temperatures at the time of the error
Inputs	Choose this to view the status of the Boiler Inputs at the time of the error
Outputs	Choose this to view the status of the Boiler Outputs at the time of the error
Lockout History 3	Choose this to view the third most recent error recorded
Fault Name	Displays the name of the fault that occurred
Fault Type	Displays the type of fault that occurred
Time	Displays time that lockout occurred
Date	Displays date that lockout occurred
Status	Displays what the status of the boiler was at the time of the error
Temperatures	Choose this to view the Boiler Temperatures at the time of the error
Inputs	Choose this to view the status of the Boiler Inputs at the time of the error
Outputs	Choose this to view the status of the Boiler Outputs at the time of the error
Manual Test Mode	
Status	Current operating status of the boiler. Prepurge, Ignition, Name of the system Type being satisfied, post purge, Warm Weather Shut down, Trouble
Inputs	Displays which inputs are presently calling for heat
Target	Calculated target temperature based on outdoor temp or the max target if no ODR
Modulation	Displays what sensor the boiler is using to modulate from. May also indicate reason for boiler rate self-limiting.
Boiler Out	Temperature of the outlet sensor on the boiler heat exchanger
Boiler In	Temperature of the inlet sensor on the boiler heat exchanger
System Supply	Temperature of the system water after the boiler loop
System Return	Temperature of the system water returning to the boiler loop
Flue	Temperature of flue gases
Outdoor	Temperature of outdoor air
Blower Signal	Control's signal controlling the blower speed
Blower Speed	Blower's feedback to the control
Flame Signal	Number indicating the presence and quality of the flame used to shut down or boost the boiler
Force Rate	Used to manually force a rate during a call for heat. Choose auto for normal operation
Manual Reset	Reset selected condition



MAINTENANCE, DATE AND TIME menus

Figure 83 MAINTENANCE, DATE AND TIME menus — navigation (see Figure 69, page 71 for access information)

Maintenance Info	Comment
Name	Contractor name to appear in maintenance reminders and during lockouts
Phone	Contractor phone number
Model	Displays the boiler model selected in the boiler setup
CP Number	Enter the CP# of the boiler
Installed	Enter the date the boiler was installed
Last Date	Date automatically entered when Reset Reminder is chosen by contractor
Next Date	Date automatically calculated when Reset Reminder is selected by contractor
Interval Settings	Contractor selects maintenance reminder frequency based on service history
Reset Reminder	Contractor selects this to update Last maintenance Date and Next Date. Homeowner uses this to ignore the reminder and update only the Next Date.

Set Time and Date	
Year	Set year (homeowner or contractor)
Month	Set month (homeowner or contractor)
Day	Set day (homeowner or contractor)
Hour	Set hour (homeowner or contractor)
Minute	Set minute (homeowner or contractor)

MAINTENANCE INFO

Use this section to enter contractor’s information, CP number, install date and to enter an automatic notice for maintenance (default is 12 months). Because this shows on the display, it is an automatic means of notifying the homeowner of need for scheduled maintenance by the technician. Select RESET REMINDER to reset for the next maintenance date.

SET TIME AND DATE

Enter current date and time. This allows correct maintenance reminder timing and provides date and time stamp for lockout histories on ERROR screen in Diagnostic Menu.



Startup — fill the system

Clean system to remove sediment

1. You must thoroughly flush the system (without boiler connected) to remove sediment. The high-efficiency heat exchanger can be damaged by buildup or corrosion due to sediment.

▲WARNING If the system needs to be cleaned, use only Sentinel X400 cleaner, available from Weil-McLain. See Figure 111, page 127 for information. Follow instructions supplied with the X400 cleaner.

2. For zoned systems, flush each zone separately through a purge valve. (If purge valves and isolation valves are not already installed, install them to properly clean the system.)
3. Flush system until water runs clean and you are sure piping is free of sediment.

▲WARNING Do not use petroleum-based cleaning or sealing compounds in boiler system. Damage to elastomer seals and gaskets in system could occur, resulting in substantial property damage.

Before filling the boiler and system with water, verify the following. **DO NOT fill with softened water.** Boiler corrosion can occur.

Failure to comply could result in boiler failure or unreliable operation.

Water chemistry

Water pH between 7.0 and 8.5

1. Maintain boiler water pH between 7.0 and 8.5. Check with litmus paper or have chemically analyzed by water treatment company.
2. If pH differs from above, consult local water treatment company for treatment needed.

Hardness less than 7 grains

1. Consult local water treatment companies for unusually hard water areas (above 7 grains hardness).

Chloride concentration must be LESS THAN 200 ppm

1. Filling with chlorinated fresh water should be acceptable since drinking water chloride levels are typically less than 5 ppm.
2. Do not use the boiler to directly heat swimming pool or spa water.
3. Do not fill boiler or operate with water containing chloride in excess of 200 ppm.

▲WARNING Verify that the water chemistry meets the limitations and requirements of all other equipment in the system.

Antifreeze

1. Use only antifreeze listed by Weil-McLain as suitable for use with **EVG** Gas Boilers. See Figure 111, page 127 for information.
2. See Replacement parts at the end of this manual for Weil-McLain part numbers to obtain antifreeze through a Weil-McLain distributor.

Use the correct amount of antifreeze

1. Determine the freezing temperature needed (to protect against lowest likely temperature the system water will encounter).
2. Find the antifreeze concentration by volume needed for this temperature from the antifreeze manufacturer's data on the antifreeze container.
3. Add up the volume (gallons) of all system piping and components, including the expansion tank and boiler.
 - a. Boiler water content is listed in Figure 125, page 140.
 - b. Remember to include expansion tank water content.
4. Multiply this volume by the (percent) antifreeze needed to find the number of gallons of antifreeze to add.

Fill and test water system

1. Fill system only after ensuring the water meets the requirements of this manual.
2. Close manual and automatic air vents and boiler drain valve.
3. Fill to correct system pressure. Correct pressure will vary with each application.
 - a. Typical cold water fill pressure for a residential system is 12 psi.
 - b. Pressure will rise when boiler is turned on and system water temperature increases. Operating pressure must never exceed 24 PSIG.
4. At initial fill and during boiler startup and testing, check system thoroughly for any leaks. Repair all leaks before proceeding further.

▲WARNING Eliminate all system leaks. Continual fresh make-up water will reduce boiler life. Minerals can build up in the heat exchanger, reducing heat transfer, overheating heat exchanger, and causing heat exchanger failure.

Purge air from water system

1. Connect a hose to the purge valve (see purge/drain valves, item 11, in piping diagrams beginning on page 50). Route hose to an area where water can drain and be seen.
2. Close the boiler or system isolation valve between the purge valve and fill connection to the system.
3. Close zone isolation valves.
4. Open quick-fill valve on cold water make-up line.
5. Open purge valve.
6. One zone at a time, open the isolation valves. Allow water to run through the zone, pushing out the air. Run until no noticeable air flow is present. Close the zone isolation valves and proceed with the next zone. Follow this procedure until all zones are purged. Follow the same procedure to purge air from the boiler and its internal piping.



Startup — fill the system *(continued)*

Freeze protection (if used)

▲WARNING Follow these guidelines to prevent possibility of severe personal injury, death or substantial property damage:

Use only the products listed by Weil-McLain for use with this boiler. See page 127 for information.

Thoroughly flush any system that has used glycol before installing the new EVG boiler.

Review the material safety data sheets (MSDS) are available online. The MSDS contains information on potential hazards and first aid procedures for exposure or ingestion.

Check antifreeze inhibitor level at least annually. Glycol concentration and inhibitor levels may change over time. Add antifreeze to increase concentration if necessary. Add inhibitor as needed to bring to acceptable level, using inhibitor test kit to verify.

In addition to antifreeze and inhibitor, use and maintain minimum level of Sentinel X100 inhibitor as directed on this page.

If using freeze protection fluid with automatic fill, **install a water meter to monitor water make-up.** Freeze protection fluid may leak before the water begins to leak, causing concentration to drop, reducing the freeze protection level.

DO NOT exceed 50% antifreeze by volume. Antifreeze moves more sluggishly than water and can interfere with heat transfer. At antifreeze concentrations higher than 50%, sludge can develop in the boiler, potentially causing damage to the heat exchanger.

Clean the system before filling. Always drain and flush the system thoroughly before filling with antifreeze. Sludge, iron oxide deposits and other sediment in the system inhibit flow and can cause rapid breakdown of inhibitors.

Use only antifreeze recommended by Weil-McLain.

NOTICE Weil-McLain provides information for application of the antifreeze products listed in this document only for use in Weil-McLain boilers. Do not apply these products or instructions for other applications. Local codes may require a backflow preventer or actual disconnection from city water supply.

7. Close the quick-fill water valve and purge valve and remove the hose. Open all isolation valves. Watch that system pressure rises to correct cold-fill pressure.
8. After the system has operated for a while, eliminate any residual air by using the manual air vents located throughout the system.
9. If purge valves are not installed in system, open manual air vents in system one at a time, beginning with lowest floor. Close vent when water squirts out. Repeat with remaining vents.
10. Open automatic air vent (diaphragm-type or bladder-type expansion tank systems only) one turn.
11. Starting on the lowest floor, open air vents one at a time until water squirts out.
12. Repeat with remaining vents.
13. Refill to correct pressure.

▲WARNING X100 inhibitor is required

1. It is required that the Evergreen® boiler have Sentinel X100 added to the system to prevent damage to the boilers' heat exchanger. See Replacement Parts section at the end of this manual for re-ordering information.
2. After filling the system as directed in these instructions, use a caulking gun to inject the X100 inhibitor concentrate into the system, or fill with the X100 in its liquid form, following the instructions on the tube or container.
3. After adding the inhibitor to the system, allow time for the water to circulate and mix. Then check the inhibitor level. Add additional inhibitor if necessary.
4. See separate instructions or Weil-McLain website for suggested guidelines to determine how much inhibitor to use.

Check/verify water chemistry

1. The system may have residual substances that could affect water chemistry.
2. After the system has been filled and leak tested, verify water pH and chloride concentrations are acceptable.
3. Verify antifreeze concentration, if used.
4. Follow the instructions on the Sentinel test kit to sample the system water and verify inhibitor concentration.

Check inhibitor concentration annually

1. Test the pH of a sample of system water at least annually. The pH of the water mixture must be between 7.0 and 8.5. (Or use the Sentinel inhibitor test kit to check concentration.)
2. If pH is outside this range (or inhibitor test kit indicates low level), the inhibitor level may not be sufficient to prevent corrosion.
3. Test antifreeze concentration.

▲WARNING Test antifreeze concentration at least annually. If concentration is low, add antifreeze or drain system and refill with correct mixture.

4. Follow instructions on antifreeze container to determine the amount of antifreeze needed. **DO NOT** exceed 50% by volume concentration of antifreeze.
5. Check inhibitor level after adjustments are made.



Startup — final checks

⚠️WARNING Check for gas leaks

Before starting the boiler, and during initial operation, use a leak detector or smell near the floor and around the boiler for gas odorant or any unusual odor. Remove boiler jacket door and smell the interior of the boiler jacket. **Do not proceed with startup if there is any indication of a gas leak. Repair any leak at once.**

DO NOT adjust or attempt to measure gas valve outlet pressure. The gas valve is factory-set for the correct outlet pressure. This setting is suitable for natural gas and propane, requiring no field adjustment. Attempting to alter or measure the gas valve outlet pressure could result in damage to the valve, causing potential severe personal injury, death or substantial property damage.

Propane boilers only — Your propane supplier mixes an odorant with the propane to make its presence detectable. In some instances, the odorant can fade, and the gas may no longer have an odor. Before startup (and periodically thereafter), have the propane supplier verify the correct odorant level in the gas.

Check thermostat circuits

1. Disconnect wires connected to the **Input 1, Input 2 and Input 3** thermostat terminals (see Field wiring, beginning on page 55 for low voltage terminal locations and application information). Mark the wires before removing to avoid wiring errors when re-connecting them.
2. Connect a voltmeter across each pair of incoming wires. Close each thermostat, zone valve and relay in the external circuits one at a time and check the voltmeter reading across the incoming wires.
3. **There should NEVER be a voltage reading.**
4. If a voltage reading is measured across the incoming wires, check and correct the external wiring.

⚠️WARNING DO NOT connect the EVG thermostat terminals to 3-wire zone valves. This could cause control damage.

5. Once the external thermostat circuit wiring is checked and corrected if necessary, reconnect the external thermostat circuit wires.

Inspect/fill condensate system

Inspect/check condensate lines and fittings

Remove floor stand front access panel to access the condensate trap. Inspect the condensate drain line, condensate PVC fittings and condensate trap. (See page 53 for component locations.)

Fill condensate trap with water

1. Slide condensate bracket away from trap then loosen the top nut that secures the condensate trap body to the boiler condensate connection (see Figure 84). Pull the trap down to disengage from heat exchanger.

Figure 84 Disconnect condensate trap assembly to fill trap body with water (front access panel removed)

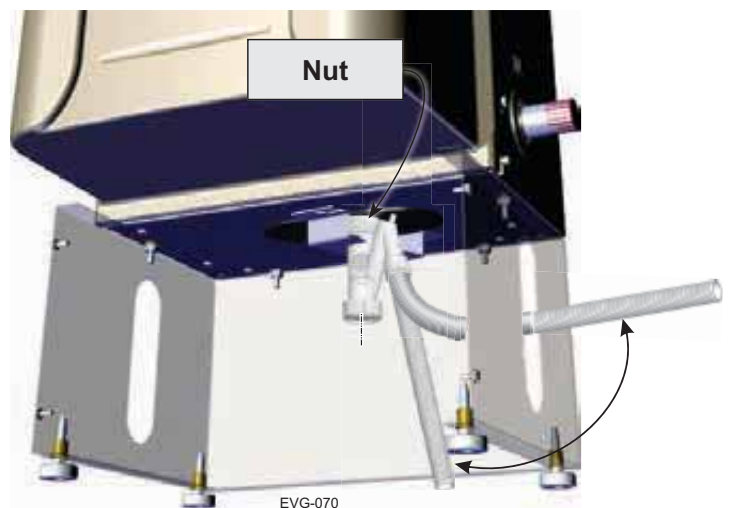

2. Pull the trap body forward enough to allow pouring water into the top of the trap.
3. Fill the trap with fresh water until water begins to run into the condensate drain tube.
4. Reattach the trap body by sliding onto the boiler condensate outlet, then retightening the trap body nut then reposition bracket under the nut by sliding the bracket under the plastic rivet in the bottom of enclosure.

⚠️WARNING The condensate trap must be filled with water during all times of boiler operation to avoid flue gas emission from the condensate drain line. Failure to fill the trap could result in severe personal injury or death.



Startup — final checks *(continued)*

Final checks before starting boiler

- Read the instructions to adjust and set up the control.
- Verify that the boiler model is set correctly in the control, and that it displays correctly.
- Verify that the boiler and system are full of water and all system components are correctly set for operation.
- Verify that condensate trap is filled with water.
- Verify electrical connections are correct and securely attached.
- Inspect vent piping and air piping for signs of deterioration from corrosion, physical damage or sagging. Verify air piping and vent piping are intact and correctly installed per this manual.

To start the boiler

1. Apply power to the boiler via the service switch.
2. Follow the Operating Instructions, Figure 85, page 95.
3. The control display will show installed sensors when first powered. Make sure the right sensors are detected and the correct boiler model is identified. If not, determine the cause and correct before proceeding.

If boiler does not start correctly

1. Check for loose connections, blown fuse or service switch off?
2. Are external limit controls (if used) open? Is boiler water temperature above 200°F?
3. Are thermostats set below room temperature?
4. Is gas turned on at meter and boiler?
5. Is incoming gas pressure less than the minimum values given on page 21?
6. Are EVG control settings correct for the application?
7. Is the warm weather shutdown activated?
8. If none of the above corrects the problem, refer to Troubleshooting, beginning on page 107.

Check system and boiler

Check water piping

1. Check system piping for leaks. If found, shut down boiler and repair immediately. (See WARNING on page 92 regarding failure to repair leaks.)
2. Vent any remaining air from system using manual vents. Air in the system will interfere with circulation and cause heat distribution problems and noise.

Check vent piping and air piping

1. Check for gas-tight seal at every connection and seam of air piping and vent piping.

▲WARNING Venting system must be sealed gas-tight to prevent flue gas spillage and carbon monoxide emissions which will result in severe personal injury or death.

Check gas piping

1. Check around the boiler and inside the boiler jacket for gas odor following the procedure of page 54 of this manual.

▲WARNING If you discover evidence of any gas leak, shut down the boiler at once. Find the leak source with bubble test and repair immediately. Do not start boiler again until corrected. Failure to comply could result in severe personal injury, death or substantial property damage.

Propane boilers — verify conversion

1. Verify boiler has been converted for propane. See page 15 for EVG 70, page 17 for EVG 110 or page 19 for EVG 155.

▲WARNING **DO NOT attempt to measure gas valve outlet pressure**

DO NOT adjust or attempt to measure gas valve outlet pressure. The gas valve is factory-set for the correct outlet pressure. This setting is suitable for natural gas and propane, requiring no field adjustment.

Attempting to alter or measure the gas valve outlet pressure could result in damage to the valve, causing potential severe personal injury, death or substantial property damage.

Evergreen® boilers are shipped ready to operate on natural gas ONLY.

Failure to comply could result in severe personal injury, death or substantial property damage.

Check flame & combustion with instruments

1. Initiate a call for heat on one of the thermostat inputs.
2. Access the EVG control installer menus by pressing and holding the UP and DOWN arrow keys for seven seconds.
3. Make sure the Max firing rate is set to the maximum given in Figure 93, page 105. If not, adjust as necessary. Then navigate to DIAGNOSTICS — Manual test mode (see Figure 79, page 85) and force the firing rate to HIGH (high fire).
4. Look at the flame through the flame inspection window. The high fire flame should be blue and should be stable. The burner surface should be covered with orange dots.
5. **Insert combustion analyzer probe** — Remove the flue temperature sensor from the flue pipe and insert a combustion test probe.
6. Test for CO₂ (or O₂) and for CO. The CO₂ values must comply with Figure 89, page 98. If results are acceptable, proceed to step 7. **IF NOT**, follow the instructions under “Throttle Screw

CONTINUED AFTER NEXT PAGE



Startup — final checks *(continued)*

Figure 85 Operating instructions (WARNING -Verify that the control is set for the correct boiler model before proceeding.)

FOR YOUR SAFETY — READ BEFORE OPERATING

⚠ WARNING

If you do not follow these instructions exactly, a fire or explosion may result causing property damage, personal injury or loss of life.

- A. This appliance does not have a pilot. It is equipped with an ignition device which automatically lights the burner. Do not try to light the burner by hand.
- B. Before OPERATING, smell all around the appliance area for gas. Be sure to smell next to the floor because some gas is heavier than air and will settle on the floor. See below.
- C. Use only your hand to turn the gas control knob. Never use tools. If the knob will not turn by hand, don't try to repair it, call a qualified service technician. Force or attempted repair may result in a fire or explosion.
- D. Do not use this appliance if any part has been under water. Immediately call a qualified service technician to inspect the appliance and to replace any part of the control system and any gas control, which has been under water.

WHAT TO DO IF YOU SMELL GAS

- Do not try to light any appliance.
- Do not touch any electric switch; do not use any phone in your building.
- Immediately call your gas supplier from a neighbor's phone. Follow the gas supplier's instructions.
- If you cannot reach your gas supplier, call the fire department.

OPERATING INSTRUCTIONS

1. **STOP!** Read the safety information above on this label. This appliance is equipped with an ignition device which automatically lights the burner. Do not try to light the burner by hand.
2. Set room thermostat(s) to lowest setting.
3. Turn OFF all electrical power to the appliance.
4. Locate boiler manual gas valve (in the gas piping connected to the boiler).
5. Turn boiler manual gas valve knob counterclockwise ↺ to OPEN gas supply.
6. Wait five (5) minutes to clear out any gas. Then smell for gas, including near the floor.
7. If you smell gas, **STOP!** Turn the boiler manual gas valve to OFF. Then follow WHAT TO DO IF YOU SMELL GAS, above. If you don't smell gas, go to step 8, below.
8. Turn ON all electrical power to the appliance.
9. Set thermostat(s) to desired setting.
10. The boiler display will show symbols and/or text describing the status of the boiler as it proceeds through its operating sequence. "Standby" status means the burner is off.
11. If the appliance will not operate when there is a call for heat and piping is not hot, follow the instructions "To Turn Off Gas To Appliance" below and call your service technician or gas supplier.

Gas valve CLOSED



Gas valve OPEN



TO TURN OFF GAS TO THE APPLIANCE

1. Set room thermostats to lowest setting.
2. Turn OFF all electrical power to the appliance.
3. Turn boiler manual gas valve knob clockwise ↻ to close gas supply.

550-101-264 (0614)



Startup — final checks *(continued)*

Adjustment” on page 96 or page 98 to set the throttle screw position. See **WARNING** on page 96 upper left.

WARNING If combustion at either high or low fire is outside the range given in Figure 89, page 98, follow the procedure given on page 96 or page 98 for adjusting the throttle screw on the venturi. If throttle screw adjustment does not correct the problem, then shut down the boiler and contact your local Weil-McLain representative. Throttle screw adjustment must be done only by a qualified technician, using calibrated test instruments. Failure to comply could result in severe personal injury, death or substantial property damage.

7. Measure natural gas input:
 - a. Operate boiler 10 minutes. Turn off other appliances.
 - b. At natural gas meter, measure time (in seconds) required to use one cubic foot of gas.
 - c. Calculate gas input:

$$\frac{3600 \times 1000}{\text{number of seconds from step b}} = \text{Btuh}$$
 - d. Btuh calculated should approximate input rating on boiler rating label.
8. Use the control display to navigate to Manual test mode (see Figure 79, page 85) and force the firing rate to LOW (low fire).
9. Look at the flame through the flame inspection window. The low fire flame should be stable and evenly distributed over burner surface with a uniform orange color.
10. Repeat the combustion test as instructed in the previous steps.
11. Use the control display to navigate to Manual test mode (see Figure 79, page 85) and force the firing rate to AUTO (normal operation).
12. Reinstall the flue gas temperature sensor. When replacing the sensor, remove the rubber grommet from the probe. Insert the rubber grommet into the flue pipe, then insert the probe into the rubber grommet.

WARNING You must reinstall the flue gas temperature sensor to prevent flue gas spillage into the boiler enclosure. Failure to comply could result in severe personal injury, death or substantial property damage.

Throttle screw adjustment EVG 70 ONLY

WARNING **DO NOT** attempt to adjust the throttle screw unless done by a qualified technician, and with the use of calibrated combustion test instruments. Adjust the throttle screw only as needed to meet the combustion values given in Figure 89.

1. Throttle screw adjustment is **only necessary** if specified elsewhere in this manual or if combustion tests indicate the need, as explained under “**Check flame & combustion with instruments**,” page 94.
2. Boiler behavior that might indicate a need to check combustion values at high fire (as per page 94) to verify boiler is in adjustment include: difficulty igniting, poor flame stability at low fire, combustion noise or high carbon monoxide values.
3. Combustion readings must be taken at both high fire and low fire. **DO NOT** attempt an adjustment of the throttle screw at low fire. Just check the combustion values.
4. See Figure 86 for location of the **EVG 70** throttle screw.

Figure 86 EVG 70 Throttle screw (ONLY for use by a qualified technician, using calibrated combustion test instruments)

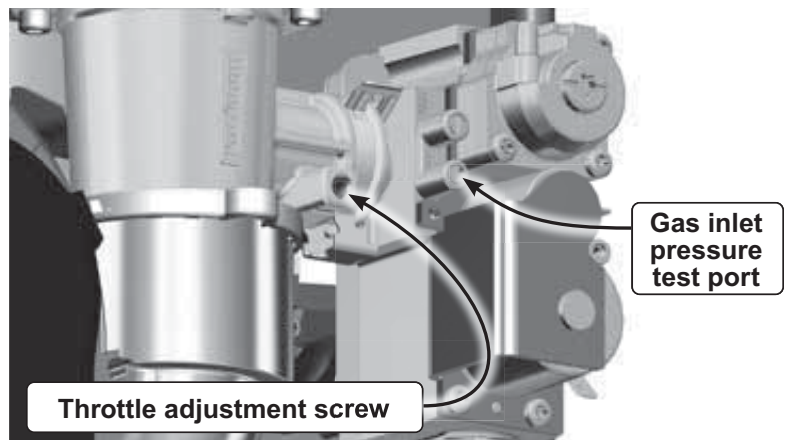

CAUTION Adjust the throttle screw in small movements. Turning the screw too far will cause the adjustment to reverse behavior.

5. Make sure the Max firing rate is set to the maximum and confirm the RPM value during operation given in Figure 93, page 105. If not, adjust as necessary. Then navigate to **DIAGNOSTICS — Manual test mode** (see Figure 79, page 85) and force the firing rate to HIGH (high fire). After the boiler has had time to stabilize, take a CO₂ reading. If result is not acceptable, do the following:
 - a. Turn the throttle screw either direction very slightly. Allow the boiler to stabilize and take another CO₂ reading. Note whether CO₂ increases or decreases.
 - b. Turn the screw slightly in the direction needed to increase or decrease reading as needed. Allow the boiler to stabilize and take another reading. Continue until CO₂ is acceptable.
 - c. Confirm that the CO is within limits.
6. Lock the boiler into low fire. Check the combustion readings. If results are acceptable at low fire, verify high fire readings again. Restore firing rate to AUTO. **DO NOT** adjust throttle on low fire.
7. Consult your local Weil-McLain representative if acceptable results cannot be obtained for both high and low fire.



Startup — final checks *(continued)*

▲WARNING If combustion at either high or low fire is outside the range given in Figure 89, page 98, follow the procedure given on page 96 or page 98 for adjusting the throttle screw on the venturi. If throttle screw adjustment does not correct the problem, then shut down the boiler and contact your local Weil-McLain representative. Throttle screw adjustment must be done only by a qualified technician, using calibrated test instruments. Failure to comply could result in severe personal injury, death or substantial property damage.

Throttle screw adjustment EVG 110 ONLY

▲WARNING **DO NOT** attempt to adjust the throttle screw unless by a qualified technician, and with the use of calibrated combustion test instruments. Adjust the throttle screw only as needed to meet the combustion values given in Figure 89.

1. Throttle screw adjustment is **only necessary** if specified elsewhere in this manual or if combustion tests indicate the need, as explained under “**□ Check flame & combustion with instruments,**” page 94.
2. Boiler behavior that might indicate a need to check combustion values at high fire (as per page 94) to verify boiler is in adjustment include: difficulty igniting, poor flame stability at low fire, combustion noise or high carbon monoxide values.
3. Combustion readings must be taken at both high fire and low fire. **DO NOT** attempt an adjustment of the throttle screw at low fire. Just check the combustion values.
4. See Figure 87 for location of the **EVG 110** throttle screw.

▲CAUTION Adjust the throttle screw in small movements.

5. Make sure the Max firing rate is set to the maximum and confirm the RPM value during operation given in Figure 93, page 105. If not, adjust as necessary. Then navigate to **DIAGNOSTICS — Manual test mode** (see Figure 79, page 85) and force the firing rate to **HIGH** (high fire). After the boiler has had time to stabilize, take a CO₂ reading. If result is not acceptable, do the following:
 - a. If the CO₂ is **HIGH**, turn the throttle screw **CLOCKWISE** to lower the input. Allow the boiler to stabilize and take another reading. Continue until the desired CO₂ value is achieved.

Figure 87 EVG 110 Throttle screw (ONLY for use by a qualified technician, using calibrated combustion test instruments)

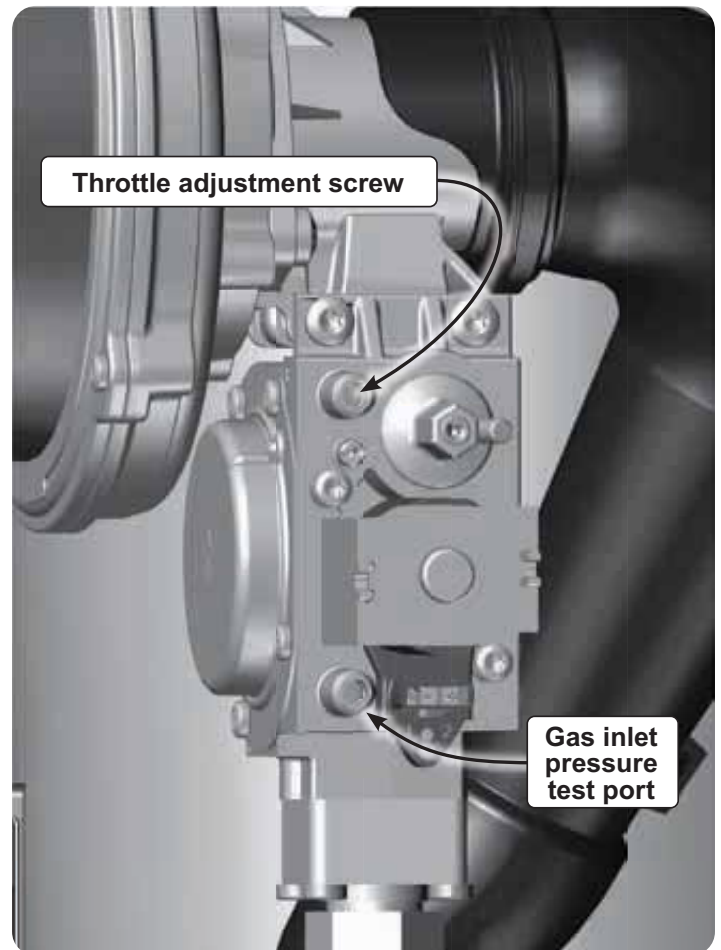

- b. If the CO₂ is **LOW**, turn the throttle screw **COUNTERCLOCKWISE** to increase the input. Allow the boiler to stabilize and take another reading. Continue until the desired CO₂ value is achieved.
 - c. Confirm that the CO is within limits.
6. Lock the boiler into low fire. Check the combustion readings. If results are acceptable at low fire, verify high fire readings again. Restore firing rate to **AUTO**. **DO NOT** adjust throttle on low fire.
 7. Consult your local Weil-McLain representative if acceptable results cannot be obtained for both high and low fire.



Startup — final checks *(continued)*

Throttle screw adjustment EVG 155 ONLY

⚠ WARNING DO NOT attempt to adjust the throttle screw unless by a qualified technician, and with the use of calibrated combustion test instruments. Adjust the throttle screw only as needed to meet the combustion values given in Figure 89.

1. Throttle screw adjustment is **only necessary** when specified elsewhere in this manual or when combustion tests indicate the need, as explained under “ Check flame & combustion with instruments,” page 94.
2. Boiler behavior that might indicate a need to check combustion values at high fire (as per page 94) to verify boiler is in adjustment include: difficulty igniting, poor flame stability at low fire, combustion noise or high carbon monoxide values.
3. Combustion readings must be taken at both high fire and low fire. DO NOT attempt an adjustment of the throttle screw at low fire. Just check the combustion values.
4. See Figure 88 for location of the **EVG 155** throttle screw.

Figure 88 EVG 155 Throttle screw (ONLY for use by a qualified technician, using calibrated combustion test instruments)



⚠ CAUTION Adjust the throttle screw in small movements.

5. Make sure the Max firing rate is set to the maximum and confirm the RPM value during operation given in Figure 93, page 105. If not, adjust as necessary. Then navigate to **DIAGNOSTICS — Manual test mode** (see Figure 79, page 85) and force the firing rate to **HIGH** (high fire). After the boiler has had time to stabilize, take a CO₂ reading.
 - a. If the CO₂ is **HIGH**, turn the throttle screw **CLOCKWISE** to lower the input. Allow the boiler to stabilize and take another reading. Continue until the desired CO₂ value is achieved.
 - b. If the CO₂ is **LOW**, turn the throttle screw **COUNTERCLOCKWISE** to increase the input. Allow the boiler to stabilize and take another reading. Continue until the desired CO₂ value is achieved.
 - c. Confirm that the CO is within limits.
6. Lock the boiler into low fire. Check the combustion readings. If results are acceptable at low fire, verify high fire readings again. Restore firing rate to **AUTO**. DO NOT adjust throttle on low fire.
7. Consult your local Weil-McLain representative if acceptable results cannot be obtained for both high and low fire.

Figure 89 Acceptable combustion values — measured values must be within the ranges given below

Boiler model EVG	Fuel	High fire		Low fire	
		% CO ₂	CO ppm	% CO ₂	CO ppm
70	NG	9.25 +/- 1.0	< 150	9.25 +/- 1.0	< 50
	LP	10.0 +/- 0.5	< 150	10.0 +/- 0.5	< 50
110	NG	9.5 +/- 0.5	< 150	9.0 +/- 0.5	< 50
	LP	10.5 +/- 0.5	< 150	10.0 +/- 0.5	< 50
155	NG	9.25 +/- 1.0	< 150	8.75 +/- 1.0	< 50
	LP	10.25 +/- 0.5	< 150	9.75 +/- 0.5	< 50

- **Values above are with the boiler jacket door removed.** Values will increase about 0.2% once the jacket door is reinstalled.
- **REINSTALL** the boiler jacket door after completing service.
- Values above are for altitudes up to 5,500 feet. For higher altitudes, CO₂ may be slightly lower and CO slightly higher.
- Low fire CO₂ should be equal to or less than High fire CO₂.

Check Heat exchanger and vent seals

1. Operate the boiler on **HIGH** fire.
2. Using an inspection mirror, move the mirror around all heat exchanger joints and vent pipe connections at the top of the boiler and at the connection to the condensate dish.
3. A leak would appear as vapor on the surface of the mirror.
4. If there is any indication of a leak at any joint, immediately shut down the boiler.
 - a. If possible, tighten the retaining screws or nuts (without over-tightening).
 - b. If this does not correct the problem, disassemble the components where the leak appeared. Use the procedures given in the Maintenance section of this manual.
 - c. When disassembling components, inspect gaskets to see if there is damage. Replace any damaged gasket.
 - d. Contact your Weil-McLain representative if the problem cannot be addressed with the information provided in this manual.
5. Condensate dish joint
 - a. If the inspection mirror check shows a leak at the condensate dish-to-heat exchanger joint, contact your Weil-McLain representative for instructions to correct the problem.
 - b. If the mirror test does not reveal a leak at the condensate dish joint, but there are signs of weepage or other indications that there might be leakage, follow the procedure for checking the heat exchanger-to-condensate dish seal.



Check-out/startup verification

Adjust and test boiler controls

1. Follow instructions in this manual to set and verify operation of the boiler controls.
2. Follow low water cutoff manufacturers instructions (if used).

Have the following been done?

- Evergreen® control set for the correct boiler model?
- Installation date and time entered into control?
- Boiler and heat distribution units filled with water?
- Water chemistry verified per page 91?
- Sentinel X100 corrosion inhibitor added and water tested to be within range?
- Automatic air vents, if used, opened one full turn?
- Air purged from system?
- Air purged from gas piping? Piping checked for leaks?
- Condensate trap primed and bracket in place?
- Propane orifice installed for propane firing and propane conversion label affixed to jacket?

⚠ WARNING Evergreen® boilers are shipped ready to operate on natural gas ONLY. To operate on propane, you must follow the instructions in this manual to install the propane orifice. See page 15 for **EVG 70** or page 17 for **EVG 110** or page 19 for **EVG 155**. Failure to comply could result in severe personal injury, death or substantial property damage.

- Thermostat circuit wiring checked to ensure there are no stray voltages?
- Followed Operating Instructions, Figure 85, page 95?
- Burner flame and combustion verified per page 94?
- Control operation for space heating and DHW (if used) verified per this manual?

- Additional field-installed controls tested as outlined by control manufacturers? (Boiler should be operating and should go off when controls are tested. Verify controls cause automatic reset lockout or manual reset lockout as desired.)
- Additional field-installed limit control(s) set to system temperature requirements? Balancing valves and controls adjusted to provide design temperature to system?
- Flow adjusted/balanced for each zone of multiple zones systems?
- Thermostat heat anticipator (if available) set properly?
- Boiler cycled with thermostats (and with DHW aquastat, if installed) — Raised to highest setting and verified boiler goes through normal startup cycle? Lowered to lowest setting and verified boiler goes off?
- Natural gas input measured? (page 96)
- Incoming gas pressure checked by connecting manometer to gas valve ahead of boiler? (Gas pressure must be at least the minimum values given on page 21, with boiler operating at high fire, and no more than 13 inches (330 mm) w.c. with boiler operating or boiler off.)
- Heat exchanger and vent seals checked with mirror to ensure no leakage?
- Observed several operating cycles for proper operation?
- Room thermostats set to desired room temperature (and DHW aquastat, if installed, to desired DHW storage temperature)?
- All instructions shipped with this boiler reviewed with owner or maintenance person?

Before leaving:

- Fill in **Installation certificate**, page 141.
- Return instructions to envelope and give to owner or place inside boiler housing.

NOTICE

Fill out start-up data on the Installation and Service Certificate, page 141.



Annual startup and general maintenance

⚠ WARNING Follow the service and maintenance procedures given throughout this manual and in component literature shipped with the boiler. Failure to perform the service and maintenance could result in damage to the boiler or system. Failure to follow the directions in this manual and component literature could result in severe personal injury, death or substantial property damage.

Figure 90 Service and maintenance schedules

Service technician (see page numbers indicated for details)		Owner maintenance (see EVG User's Information Manual)	
ANNUAL START-UP (See First-year special inspection)	• Address reported problems		
	• Inspect boiler area		
	• Inspect boiler interior & jacket door gaskets.		
	• Clean condensate trap.		
	• Check all piping for leaks		
	• Check air openings		
	• Flue vent system and air piping		
	• Check water system		
	• Check expansion tank(s).		
	• Inspect ignition electrode		
	• Check ignition wiring.		
	• Check all boiler wiring		
	• Check control settings.		
	• Perform startup and checks		
	• Check low water cutoff service light.		
	• Check burner flame		
	• Check flame signal.		
	• Check blower speeds		
	• Check flue gas temperature		
	• Manual Test Mode for Single and Multiple Boilers.		
• Check boiler relief valve			
• Reinstall jacket door after servicing			
• Review with owner.			
	Daily	<ul style="list-style-type: none"> • Check boiler area. • Check air openings. • Check pressure/temperature gauge. • Verify boiler jacket door is securely in place. 	
	Monthly	<ul style="list-style-type: none"> • Check vent piping. • Check air piping. • Check relief valve. • Check condensate drain system. • Check automatic air vents (if used). • Verify that domestic hot water is being supplied to fixtures at the correct temperature. 	
	Every 6 months	<ul style="list-style-type: none"> • Check boiler piping (gas and water) • Operate relief valve. 	



Annual startup

HANDLING CERAMIC FIBER MATERIALS

REMOVING BURNER GASKET or COVER PLATE INSULATION

▲WARNING The EVG cover plate refractory contain ceramic fiber materials that have been identified as carcinogenic, or possibly carcinogenic, to humans.

Ceramic fibers can be converted to cristobalite in very high temperature applications.

The International Agency for Research on Cancer (IARC) has concluded, “Crystalline silica inhaled in the form of quartz or cristobalite from occupational sources is carcinogenic to humans (Group 1).”:

- Avoid breathing dust and contact with skin and eyes.
 - Use NIOSH certified dust respirator (N95). This type of respirator is based on the OSHA requirements for cristobalite at the time this document was written. Other types of respirators may be needed depending on the job site conditions. Current NIOSH recommendations can be found on the NIOSH web site at <http://www.cdc.gov/niosh/homepage.html>. NIOSH approved respirators, manufacturers, and phone numbers are also listed on this web site.
 - Wear long-sleeved, loose fitting clothing, gloves, and eye protection.
- Handle carefully to minimize dust that could be caused by abrasion.
- If replacement is necessary, remove the refractory from the boiler and place it in a plastic bag for disposal.
- Wash potentially contaminated clothes separately from other clothing. Rinse clothes washer thoroughly.

NIOSH stated First Aid

- Eye: Irrigate immediately
- Breathing: Fresh air.

FIRST-YEAR SPECIAL INSPECTION

NOTICE

It is recommended that you obtain a Weil-McLain Boiler Maintenance kit before attempting the first-year inspection, to ensure all parts that may be needed are available. This kit includes a heat exchanger cover plate gasket, burner gasket, new ignitor, and ignitor gasket. See listing in Replacement parts section of this manual. These parts must be on hand when you perform the first-year inspection in the event they must be replaced.

▲WARNING

Failure to replace the items above when needed could result in severe personal injury, death or substantial property damage.

1. **No later than 12 months** after the boiler is installed, perform a first-year inspection of the boiler. This should include the following **in addition to routine annual start-up procedures**.
 - a. Inspect the heat exchanger and clean if necessary (see page 117, EVG 70 or 110, or page 123, EVG 155, for access and cleaning procedures).
 - b. Inspect the cover plate refractory and gasket. Replace if not in good condition.
 - c. Inspect the burner and inspect carefully. Clean the burner thoroughly using a vacuum cleaner and compressed air if needed.
 - d. Make sure there is no blockage or accumulation of debris in the burner or the burner ports. Replace the burner if necessary.
 - e. EVG 70 or 110: Check the burner for tightness. Remove the cover plate refractory and tighten the burner mounting screws if needed, following the instructions on page 117.
 - f. EVG 155: Check burner access cover for tightness.
 - g. Make sure to follow the inspection procedure given in “Check exchanger and vent seals,” page 98.
 - h. Disconnect the condensate trap and drain lines. Inspect, then flush thoroughly. Reinstall and refill the trap per page 93.
2. Determine any follow-up maintenance and service needs based on the condition of the heat exchanger and condensate lines.
 - a. If the heat exchanger shows substantial fouling, or if condensate lines show accumulation of sediment, schedule a follow-up service call to perform the first-year inspection again, sooner than the normal twelve months between.
 - b. Heavy fouling of the exchanger or condensate lines indicates possible combustion air contamination. Inspect the air intake area carefully, and remove possible contaminants. See page 22, for products to avoid.

▲WARNING

You must eliminate causes of corrosion and contamination to ensure reliable operation of the boiler and system.



Annual startup *(continued)*

⚠ WARNING The boiler should be inspected and started annually, at the beginning of the heating season, only by a qualified service technician. In addition, the maintenance and care of the boiler designated in Figure 90, page 100 and explained on the following pages must be performed to assure maximum boiler efficiency and reliability. Failure to service and maintain the boiler and system could result in equipment failure.

⚠ WARNING Electrical shock hazard — Turn off power to the boiler before any service operation on the boiler except as noted otherwise in this instruction manual. Failure to turn off electrical power could result in electrical shock, causing severe personal injury or death.

Address reported problems

1. Inspect any problems reported by owner and correct before proceeding.

Inspect boiler area

1. Verify that boiler area is free of any combustible materials, gasoline and other flammable vapors and liquids.
2. Verify that air intake area is free of any of the contaminants listed on page 22 of this manual. If any of these are present in the boiler intake air vicinity, they must be removed. If they cannot be removed, reinstall the air and vent lines per this manual.

Inspect boiler interior & jacket door gaskets

1. Remove jacket door and inspect interior of boiler.
2. Visually inspect the jacket door gaskets on front of cabinet. Make sure all are in good condition. Obtain replacements if any gasket is damaged.

⚠ WARNING Jacket door gaskets must be intact, and must provide a reliable seal. Replace any damaged gasket.

3. Remove the venturi air inlet silencer and clean if necessary. Reinstall silencer.
4. Vacuum any sediment from the inside of the boiler and components. Remove any obstructions.

⚠ WARNING Do not use solvents to clean any of the boiler components. The components could be damaged, resulting in unreliable or unsafe operation.

Clean condensate trap

1. See Figure 91.
2. Remove floor stand front access panel to access the condensate trap, if floor standing.
3. Slide bracket off of condensate trap then disconnect top nut that secures the trap body to the boiler condensate connection (see Figure 59, page 53).
4. Remove the cleanout cap and remove the trap internal parts as shown.
5. Clean all trap components.
6. Re-assemble trap assembly. Re-install all lower gaskets.
7. Make sure the trap ball moves freely when re-inserted.
8. Fill trap with fresh water by pouring into the top of the trap body. Continue filling slowly until water begins flowing out the condensate drain line. Make sure the trap line is unobstructed and flows freely.
9. Reattach the trap to the boiler condensate outlet. Push the trap up until fully engaged. Then twist the upper nut clockwise to tighten. Check for secure connection. Place bracket under top nut and slide slot over rivet in cabinet, check for secure connection.

Figure 91 Condensate trap cleaning

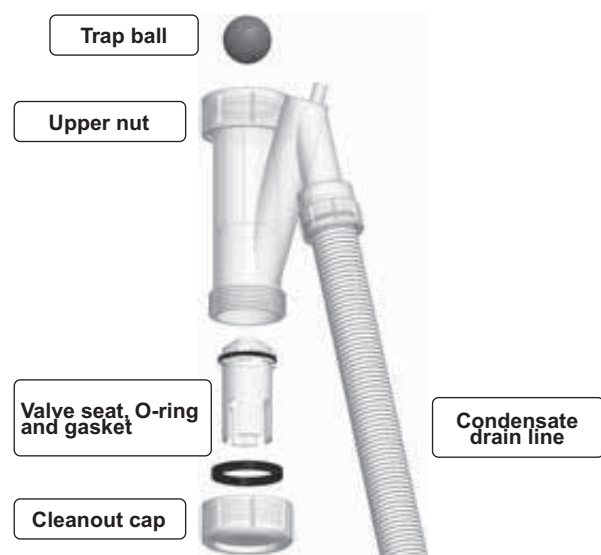

Check all piping for leaks

⚠ WARNING Eliminate all system or boiler leaks. Continual fresh make-up water will reduce boiler life. Minerals can build up in the heat exchanger, reducing heat transfer, overheating heat exchanger, and causing heat exchanger failure. Leaking water may also cause severe property damage.

1. Inspect all water and gas piping and verify to be leak free.
2. Look for signs of leaking lines in the system and in the boiler and correct any problems found.
3. Check gas line using procedure on page 54.



Annual startup *(continued)*

Check air openings

1. Verify that combustion and ventilation air openings to the boiler room and/or building are open and unobstructed.
2. Check operation and wiring of automatic combustion air dampers, if used.
3. Verify that boiler vent discharge and air intake are clean and free of obstructions.

Flue vent system and air piping

1. Visually inspect entire flue gas venting system and combustion air piping for blockage, deterioration or leakage. Repair any joints that show signs of leakage in accordance with vent manufacturer's instructions. Verify that air inlet piping is connected and properly sealed.

▲WARNING Failure to inspect for the above conditions and have them repaired can result in severe personal injury or death.

Check water system

1. Verify all system components are correctly installed and operational.
2. Check the cold fill pressure for the system. Verify it is correct (usually around 12 PSIG).
3. Watch the system pressure as the boiler heats up (during testing) to ensure pressure doesn't rise too high. Excessive pressure rise indicates expansion tank sizing or performance problem.
4. Inspect automatic air vents and air separators. Remove air vent caps and briefly press push valve to flush vent. Reinstall caps. Make sure vents do not leak. Replace any leaking vents.
5. Check system water chemistry (pH, hardness and inhibitor level). See page 91.

Check expansion tank(s)

1. Expansion tanks provide space for water to move in and out as the heating system water expands due to temperature increase or contracts as the water cools.
2. See page 43 or page 47 depending on system type for information.
3. Tank types
 - **Closed-type** — welded gas tight and located above boiler. Tank is partially filled with water, leaving an air cushion for expansion.
 - Make sure a closed-type tank is fitted with a tank fitting, such as the B & G Tank-trol or Taco Taco-trol. This fitting reduces gravity circulation of air-saturated tank water back to the system and prevents the air from bubbling up through the water as it returns from the system.

- Do not use automatic air vents in systems with closed-type tanks. The air will escape from the system instead of returning to the tank.
 - Eventually, the tank will waterlog and no longer control pressurization. The boiler relief valve will weep frequently.
 - **Diaphragm- or bladder-type** — welded gas tight with a rubber membrane to separate the tank pressurizing air and the water. May be located at any point in the system, but preferably located on the suction side of the system circulator.
 - Systems with this type of expansion tank require at least one automatic air vent, preferably located on top of an air eliminator, as shown in examples in this manual.
4. If relief valve has tended to weep frequently, the expansion tank may be water logged or undersized.
 - a. **Diaphragm- or bladder-type expansion tank** — first, check tank size to be sure it is large enough for the system. If size is too small, add additional tank (or tanks) as necessary to provide sufficient expansion. If tank size is large enough, remove tank from system and check charge pressure (usually 12 PSIG for residential applications). If tank won't hold pressure, membrane has been damaged. Replace tank.
 - b. **Closed-type expansion tank** — tank is most likely waterlogged. Install a tank fitting if not already installed. Then check fill level per fitting manufacturer's instructions. If fill level is correct, check tank size against manufacturer's instructions. Replace with a larger tank if necessary.

Inspect ignition electrode

1. Remove the ignition electrode from the boiler heat exchanger access cover (see item 23, page 4). Disconnect the ground wire and ignition cable connected to the electrode.
2. Discard the ignition electrode gasket.
3. Remove any white oxides accumulated on the ignition electrode using steel wool. If the ignition electrode cannot be cleaned satisfactorily, replace ignitor with a new one.
4. Slide new gasket on to the ignition electrode. Reinstall ignition electrode, making sure gasket is in good condition and correctly positioned.

▲WARNING **TORQUE LIMIT** — Use a torque wrench when tightening the two ignition electrode retainer screws. DO NOT exceed 20 inch-pounds.



Annual startup *(continued)*

Check ignition wiring

1. Check ignition cable electrical resistance. A good cable will have resistance between 950 and 1050 ohms. Replace if not acceptable.
2. Inspect boiler ground wire from heat exchanger access cover to ground terminal screw.
3. Verify all wiring is in good condition and securely attached.
4. Check ground continuity of wiring using continuity meter.
5. Replace ground wires if results are not satisfactory.

Check all boiler wiring

1. Inspect all boiler wiring, making sure wires are in good condition and securely attached.
2. Verify that all connectors are securely inserted.

Check control settings

1. Use the control display to navigate through all settings. Adjust settings if necessary.
2. Check settings of external limit controls (if any) and adjust if necessary. Adjust as needed to accommodate the system design.

Perform startup and checks

1. Start boiler and perform checks and tests specified in this manual.
2. Verify cold fill pressure is correct and that operating pressure does not go too high. Adjust water pressure and expansion tank charge pressure as necessary.
3. Complete the check-out procedure on page 99.

Check low water cutoff service light

1. If the low water cutoff amber LED is on, the device requires service. Follow the low water cutoff manufacturer's instructions. (Shipped as standard equipment with all Evergreen® boilers).

Check burner flame

⚠WARNING The boiler contains ceramic fiber materials. Use care when handling these materials per instructions on page 101 of this manual. Failure to comply could result in severe personal injury.

1. Inspect flame through observation window using the procedure on page 94.
2. If flame is unsatisfactory at either high fire or low fire, check combustion values. If combustion is properly adjusted, turn off boiler and allow boiler to cool down. Then remove burner and clean it thoroughly using a vacuum cleaner or compressed air. Do not use compressed air to clean burner if performed inside a building.
3. To access the burner, remove the heat exchanger cover plate following the procedure beginning on pages 117 or page 120 or page 123 .
4. If replacing the burner, ensure the burner gasket is in good condition and correctly positioned. Follow all instructions on page 117 or 103 to reinstall all components.
5. Restart the boiler.
6. Inspect the flame at high and low fire. If flame is still not acceptable, check combustion values. If combustion is properly adjusted, obtain a replacement burner from Weil-McLain.

Check flame signal

1. Navigate to Diagnostics/Inputs on the control display (see Figure 72, page 79 for navigation instructions and Figure 78, page 84 for the complete Diagnostics menus).
2. The flame signal value must be at least 75 for a **EVG 70**, or at least 100 for a **EVG 100**, and at least 160 for the **EVG 155**. If the flame signal drops below this level, the **EVG** control will attempt to correct by increasing the blower speed to increase flame signal.

Figure 92 Flame signal shutdown values

Model EVG	Shutdown flame signal	Model EVG	Shutdown flame signal
70	50	155	150
70 HA	50	155HA	150
110	80	NOTE: "HA" means high altitude, 5500 feet or more above sea level.	
110 HA	80		

3. A low flame signal may indicate a fouled ignitor or damaged ignitor insulation.
 - a. See "Inspect ignition electrode," page 103 to remove and inspect the ignitor.
 - b. If required, clean the igniter as instructed.
 - c. If cleaning the ignitor does not improve, ground wiring is in good condition, and ground continuity is satisfactory, replace the ignitor.
4. If flame signal still remains low:
 - a. Inspect the vent and air piping.
 - b. Check combustion values.
 - c. Then inspect the heat exchanger, following the procedures given in this manual for removal and reinstallation of the heat exchanger cover plate and other boiler components (see page 117).
 - d. Clean the exchanger as described in this manual if necessary.

Check blower speeds

1. For installations at altitudes above 5,500 feet, make sure the control is set up for high altitude in the boiler setup menu. The control automatically adjusts low fire and ignition rates to compensate for high altitude conditions.
2. For installations below 5,500 feet, high altitude should NOT be enabled.
3. Use the control display to navigate to DIAGNOSTICS/Manual test mode (see Figure 72, page 79 for navigation instructions and Figure 78, page 84 for the complete Diagnostics menus).
4. Set the firing rate to LOW (low fire).
5. Write down the blower RPM value shown and compare to the value in Figure 93. The value should be no less than the "Minimum setting" and no higher than the Ignition "Factory setting" listed. Low fire rate (and corresponding blower speed) is adjusted in the boiler setup menu.
6. Set the firing rate to MED (ignition rate).
7. Write down the blower RPM value. It should be within 200 RPM of the value listed in Figure 93.
8. Set the firing rate to HIGH (high fire).



Annual startup *(continued)*

9. Write down the blower RPM value. It should be within 200 RPM of the value given in Figure 93.
10. If any of the values are outside the ranges listed in the previous steps, contact the factory for technical assistance.

NOTICE Minimum and maximum blower speeds can be adjusted within limits, but changing speeds will affect AFUE ratings.

Check flue gas temperature

1. Set the boiler to high fire. Then adjust the EVG control display to view flue gas temperature and boiler return temperature.
2. The flue gas temperature should be no more than 50°F higher than the boiler return temperature.
3. If the flue temperature is higher than this, shut down the boiler, allow to cool, and follow the procedure starting on page 117 to clean the heat exchanger.

Manual Test Mode for Single and Multiple Boilers

Single Boiler

1. Navigate to Manual Test Mode screen under DIAGNOSTICS menu.
2. Generate a call for heat and wait until the burner is lit, if not yet in operation.
3. Press ENTER and select the desired FORCE RATE. Rate will be forced to setting for 10 minutes.

Multiple Boiler Running

1. Generate a call for heat on a Network Priority or a Local Priority
 - a. Local Priority—allows Force Rate only on the boiler with the call for heat. Follow Single Boiler procedure, above.
 - b. Network Priority—allows Force Rate on any boiler in the network. Follow procedure outline below in steps 2-5.
2. On the Master boiler, navigate to Manual Test Mode screen under DIAGNOSTICS menu. Select desired boiler to be tested.
3. The Manual Test Mode screen will automatically appear on the boiler you selected. On the selected boiler's control, press ENTER and select the desired FORCE RATE (HIGH, MED, OR LOW).

CAUTION When forcing a rate on a Network Priority call, only boilers running Local Priority calls will remain on. All other boilers on the network will not fire until the Manual Test has ended. Ensure critical applications remain heated. Long periods of low heating can cause property damage.

4. The selected boiler will run at the forced rate until it is either returned to AUTO, the user selects "End Manual Test" on the Master's Manual Test Mode screen, or after 30 minutes of inactivity on the Master control.
5. To test the next boiler, return to the master and select the next desired boiler to test.

Figure 93 Firing rates and corresponding blower speeds (low fire, ignition, and high fire) — for altitudes up to 5,500 feet and high altitude (above 5,500 feet)

EVG Model	70			110			155		
	%	RPM	Btu/Hr Note 1	%	RPM	Btu/Hr Note 1	%	RPM	Btu/Hr Note 1
Low fire									
Minimum setting	20	1,100	14,000	20	1,900	22,000	20	1,300	28,000
Factory setting	20	1,100	14,000	20	1,900	22,000	20	1,300	28,000
High altitude	33	1,675	23,000	33	2,890	37,000	34	2,100	52,000
Ignition ("Medium" setting in manual test mode)									
Factory setting	47	3,200	32,900	50	4,130	55,000	48	2,800	72,850
High altitude	62	3,500	43,400	61	4,975	67,500	61	3,500	94,550
High fire (adjust if desired to match maximum system load — High fire % rate = Max heat load / Boiler output) (adjusting speed will affect boiler AFUE rating)									
Factory setting	96	4,150	67,200	96	7,550	105,600	96	5,300	148,800
Maximum setting	100	4,300	70,000	100	7,850	110,000	100	5,500	155,000

Note 1 — The boiler will automatically derate the BTU values listed in this table by 4% per 1,000 feet above sea level.

NOTICE In the USA Input rates are derated 4% for each 1000 ft. above sea level, beyond 2000 ft. in accordance with National Fuel Gas Code, ANSI Z223.1/NFPA 54 – latest edition, and/or the Natural Gas and Propane Installation Code, CAN/CSA B149.1.

WARNING For elevations above 10,000 feet, please contact Weil-McLain Technical Support for details.

NOTICE In Canada, Input rates are derated 10% for altitudes of 2000 ft. to 4500 ft. above sea level. Please use appropriate Fan Speed Settings for High Altitude provided in this manual.

In Canada for elevation beyond 4500 feet. Please consult Provincial Authorities having jurisdiction and/or local codes.



Annual startup *(continued)*

Check boiler relief valve

1. Inspect the relief valve and lift the lever to verify flow as in the following warnings, excerpted from a relief valve manufacturer's warning label. Before operating any relief valve, ensure that it is piped with its discharge in a safe area to avoid severe scald potential.
2. Read page 45 or 49 before proceeding further.
3. Follow instructions below or perform procedures per relief valve manufacturer's printed instructions.

▲WARNING Safety relief valves should be reinspected AT LEAST ONCE EVERY THREE YEARS, by a licensed plumbing contractor or authorized inspection agency, to ensure that the product has not been affected by corrosive water conditions and to ensure that the valve and discharge line have not been altered or tampered with illegally. Certain naturally occurring conditions may corrode the valve or its components over time, rendering the valve inoperative. Such conditions are not detectable unless the valve and its components are physically removed and inspected. This inspection must only be conducted by a plumbing contractor or authorized inspection agency — not by the owner. Failure to reinspect the boiler relief valve as directed could result in unsafe pressure buildup, which can result in severe personal injury, death or substantial property damage.

▲WARNING Following installation, the valve lever must be operated AT LEAST ONCE A YEAR to ensure that waterways are clear. Certain naturally occurring mineral deposits may adhere to the valve, rendering it inoperative. When manually operating the lever, water will discharge and precautions must be taken to avoid contact with hot water and to avoid water damage. Before operating lever, check to see that a discharge line is connected to this valve directing the flow of hot water from the valve to a proper place of disposal. Otherwise severe personal injury or property damage may result. If no water flows, valve is inoperative. Shut down boiler until a new relief valve has been installed.

4. After following the above warning directions, if the relief valve weeps or will not seat properly, replace the relief valve. Ensure that the reason for relief valve weeping is the valve and not over-pressurization of the system due to expansion tank waterlogging or under-sizing.

Reinstall jacket door after servicing

▲WARNING

Reinstall boiler jacket door after start-up or servicing. The boiler jacket door must be securely fastened to the boiler to prevent boiler from drawing air from inside the boiler room. This is particularly important if the boiler is located in the same room as other appliances.

Inspect boiler jacket door gaskets on front of cabinet. Gaskets must be in good condition, with no tears or gaps. Replace if necessary.

Failure to keep the jacket door securely sealed and fastened could result in severe personal injury or death.

Review with owner

1. Review the User's Information Manual with the owner.
2. Emphasize the need to perform the maintenance schedule specified in the User's Information Manual (and in this manual as well).
3. Remind the owner of the need to call a licensed contractor should the boiler or system exhibit any unusual behavior.
4. Remind the owner to follow the proper shutdown procedure and to schedule an annual startup at the beginning of the next heating season.



Troubleshooting

VERIFY PROPER OPERATION AFTER SERVICING

Before calling for troubleshooting assistance, fill in the “**EVG Gas Data Collection Sheet**” (page 144). Record the boiler size and CP number (located on the right side exterior of the boiler jacket).

BEFORE TROUBLESHOOTING —

⚠ WARNING Failure to adhere to these guidelines can result in severe personal injury, death or substantial property damage.

ELECTRICAL SHOCK HAZARD

TURN OFF ALL POWER TO THE BOILER WHEN SERVICING.

DO NOT JUMPER DEVICES

Never jumper (bypass) any device except for momentary testing.

REINSTALL Jacket door

The boiler jacket door must be securely fastened to the boiler to prevent boiler from drawing air from inside the boiler room. This is particularly important if the boiler is located in the same room as other appliances. Failure to keep the jacket door securely fastened could result in severe personal injury or death.

BEFORE SERVICING or MAKING CONNECTIONS —

ALWAYS TURN POWER OFF TO THE BOILER TO PREVENT ELECTRICAL SURGES, WHICH CAN DAMAGE BOILER COMPONENTS.

LABEL WIRES BEFORE REMOVING

Label all wires prior to disconnection when servicing controls. Wiring errors can cause improper and dangerous operation.

1. See Figure 94 for tools and kits recommended for troubleshooting **Evergreen®** boilers.
2. Check for 120 VAC (minimum 102 VAC to maximum 132 VAC) to boiler.
3. Check the control’s last three lockout histories. (Navigate to the DIAGNOSTICS menus.)
 - a. See Figure 72, page 79 for navigation instructions and Figure 78, page 84 for the complete Diagnostics menus.
 - b. In the DIAGNOSTICS menu, scroll down to PAST ERRORS and press the enter key.
 - c. Record the first four data records and then highlight the history record you want to view.
 - d. Record the fault counts, (Control Faults, Ignition Retries, Manual Reset Count, Auto Reset Count) and then highlight the history record you want to view.
 - e. Follow information at the bottom of the screen to navigate through your lockout histories.

Figure 94 Tools and kits needed for troubleshooting

Tool	Purpose
#2 Phillips screwdriver	Multiple uses
3 mm Allen wrench	For removing igniter and flame sense screws
10 mm wrench	To remove heat exchanger cover plate
T20 long-handled Torx driver	To remove burner screws
T25 Torx driver	To remove gas valve
5/16" Nut driver or socket	To remove air baffle
Multimeter	Measurements on sensors and electrical components
Manometer (Inclined or digital)	Measure the INLET gas pressure to the boiler
Combustion analyzer (Digital preferred)	Combustion testing and boiler adjustments
Contact thermometer	Checking surface temperatures of heat exchanger and pipes
Maintenance kit	ALWAYS have this kit on hand when performing maintenance in case replacement is required.

Check the following:

1. Make sure thermostat is calling for heat and contacts (including appropriate zone controls) are closed. Check for 24 VAC between thermostat wire nuts and ground.
2. Make sure all external limit controls are either installed (and closed) or temporarily jumpered for testing.
3. Make sure that connectors to the control are securely plugged in at module and originating control.
4. Gas pressures:
 - Maximum: 13" (330 mm) w.c. with no flow (gas valve lockup pressure).
 - Minimum: must be no less than the minimum values given on page 21 while operating on high fire.



Troubleshooting *(continued)*

Check control fuses

⚠ WARNING ALWAYS check control fuses before replacing the control or any major components (blower, etc.). If one of these fuses is blown, it can prevent the control or other components from operating.

1. Turn OFF power to boiler at external line switch. Then remove the jacket door.
2. Locate fuses using Figure 96.
3. Remove and inspect the two (2) fuses (items 1 and 2, Figure 96).
4. If necessary, replace one or both of the fuses:
 - a. Low voltage circuit fuse is 3-amp fast-blow (Littelfuse 0287003).
 - b. Line voltage circuit fuse is 12-amp fast-blow (Littelfuse 0314012MXP or Bussman ABC-12-R).

⚠ WARNING Do not jumper either fuse or replace with any fuse except as specified. Failure to comply could result in severe personal injury, death or substantial property damage.

Checking temperature sensors

1. The boiler temperature sensors (flue, outdoor, return water, supply water and system) are all resistance-type devices. Figure 95 shows the correct value for the sensor at various temperatures. For dual sensors, the temperature difference between the sensors must be no more than 10°F.
2. Use the resistance values at 32°F, 60°F, 70°F and 212°F to measure the sensor resistance at known temperatures (ice point, room temperature and sea level boiling point). For ice point and boiling point, insert the sensor in water at that temperature. Use an ohmmeter to read resistance value.
3. To check whether the control is correctly sensing temperature, you can use a resistance decade box. Connect the decade box temporarily in place of a sensor and read the corresponding temperature on the control display. The temperature should be close to the value corresponding to the input resistance.

Figure 96 Control fuses



Figure 95 Sensor resistance values

Temp (°F)	Sensor ohms		Temp (°F)	Sensor ohms		Temp (°F)	Sensor ohms	
	Min	Max		Min	Max		Min	Max
32	34265	37871	90	8504	9399	150	2517	2782
40	27834	30764	100	6847	7568	160	2091	2311
50	21630	23907	110	5545	6129	170	1744	1928
60	16944	18727	120	4517	4992	180	1461	1615
70	13372	14780	130	3698	4088	190	1229	1359
80	10629	11747	140	3043	3364	200	1038	1147



Troubleshooting *(continued)*

WARNING Make sure to determine the causes of outages. Do not leave the boiler operating without a complete diagnosis.

Control fault indications

1. The control provides diagnostic information for both automatic reset conditions and manual reset conditions. See Figure 69, page 71 for information available on the control display and navigation instructions for all menus.
2. Figure 97 shows the screen behavior during a fault condition. The display illustration and text below in Figure 97 shows how to reset faults from the Home Owners screen.
3. Figure 99, page 110 lists conditions that will cause the control to display a constant red screen. The boiler will automatically restart if the condition self-corrects or the technician uses the control's manual reset screens to reset.

Figure 97 Control display toggles when in lockout, with screen flashing red to gray

NOTICE: Screen background color alternates from RED to no backlight (gray screen).

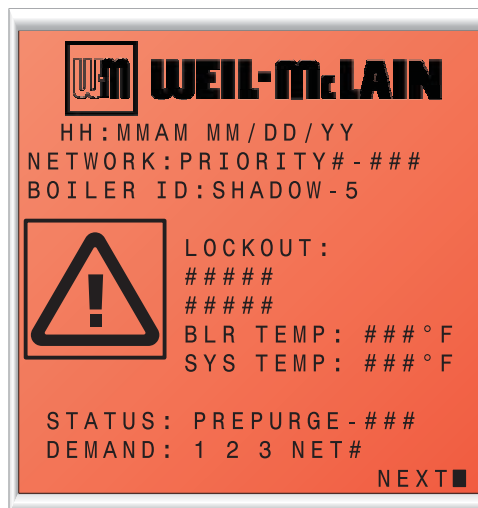

SEE TOP LINE OF DISPLAY FOR ERROR

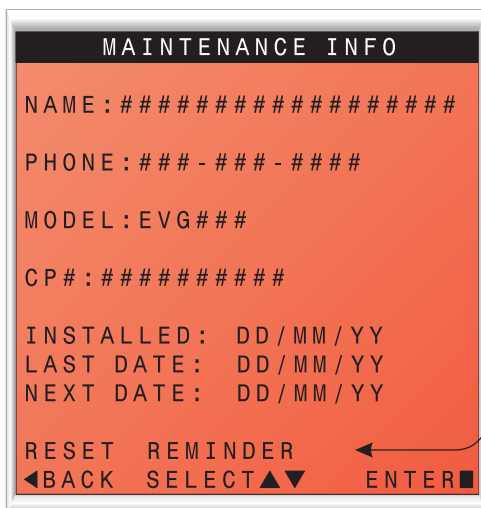

Select **MANUAL RESET** to reset condition. Make sure to correct the cause of the problem if possible.

Select **RESET REMINDER** to reset the counter. The reset reminder will not occur again until the INTERVAL time has elapsed.

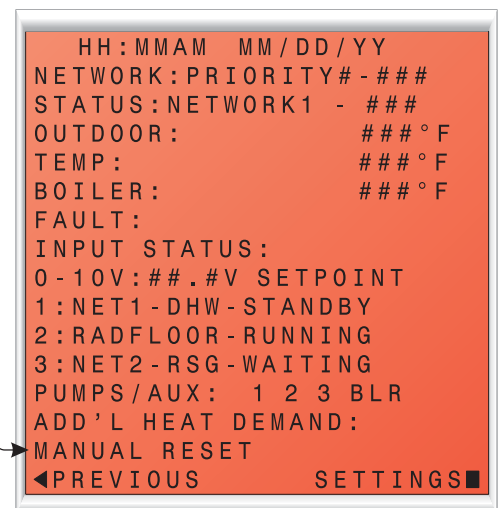

EV-032



Troubleshooting *(continued)*

Figure 98 Troubleshooting suggestions for EVG boilers — **EVG control Error Condition Log**

RESET TO FACTORY DEFAULT

1. Selecting this will prompt the user to hold the enter button for a specified length of time. Upon completion, this will reset the control settings back to factory installed settings.
ONCE THIS IS CHOSEN, PREVIOUS SETTINGS CANNOT BE RECOVERED. ENSURE THIS ACTION IS TRULY DESIRED BEFORE CONTINUING.
2. Reset to Factory Default can be found on the BOILER SETTINGS menu, see Figure 72, page 79.

Figure 99 Troubleshooting suggestions for Evergreen® boilers — **Control Error Condition Log**

The Control is able to record information about the boiler’s condition at the time of the three previous faults or errors. This information is available to view in Contractor Menus under “DIAGNOSTICS” by selecting “PAST ERRORS.” The control will display the following information:

Information	Description	Action
Control Fault	Records the number of internal control faults.	Press the < + > key to reset this count.
Ignition Retries	Displays cumulative ignition attempts. It is recommended that his be reset during yearly maintenance.	Press the < + > key to reset the count or select this parameter and press enter to reset.
Manual Reset Count	Records number of lockouts that required a manual reset since this count was last cleared.	Press the < + > key to reset this count.
Auto Reset Count	Records number of lockouts that have automatically reset since this count was last cleared.	Press the < + >- key to reset this count.
Lockout History 1	Details of present or last recorded lockout.	Select and press the enter key for more details.
Lockout History 2	Details of boiler during the second oldest lockout still in memory.	Select and press the enter key for more details.
Lockout History 3	Details of boiler during the oldest lockout still in memory.	Select and press the enter key for more details.

How to read the last 3 lockout histories:

1. Scroll down to “DIAGNOSTICS” and press the enter key (Square Key in center).
2. Scroll down to “PAST ERRORS” and press the enter key (Square Key in center).
3. Scroll down to “LOCKOUT HISTORY #” and press the enter key(Square Key in center).
4. Review fault information displayed on screen.
5. Scroll up or down to highlight other choices and press the enter key to view the details of the boiler’s condition when the lockout was recorded.

How to clear all lockout histories:

1. While on the “PAST ERRORS” screen, hold the Left and Right arrow buttons simultaneously for 7 seconds.



Troubleshooting *(continued)*

Figure 100 Troubleshooting suggestions for EVG boilers — **Fault displays, diagnostics and corrective actions**

Display	Condition	Diagnostics	Corrective Action(s)
Nothing shown on display screen and boiler will not respond to call for heat	Control is not receiving 24V power.	Check wiring for short circuit or incorrect wiring.	Correct wiring per wiring diagram including connection of transformer to the control.
		Check 3-amp low voltage fuse on control shown on page 108.	Replace fuse with proper part found in replacement part section of this manual. If fuse blows again recheck wiring per diagram.
		Check transformer connection to the control per wiring diagram. Check for 24V output of transformer.	Replace transformer if it is receiving 120VAC, but not outputting 24VAC.
Nothing is shown in display screen and no other boiler components are operating	Control is not receiving 120V power.	Check service switch and/or circuit breaker to boiler is turned on.	Turn on service switch to power boiler.
		Is there 120 VAC at the service switch?	Troubleshoot and correct the power supply to the service switch.
		Check for 120 VAC at the line voltage terminal block located at P1 on the control module.	Correct wiring to control module using the wiring diagram in this manual.
		Inspect 12-amp fuse as shown on page 108. Replace if necessary.	Replace the fuse with proper part found in the replacement part section of this manual. If fuse blows again recheck wiring per diagram.
Nothing is shown on display screen, but boiler is operating	Occurs if the communication is lost from the control to the display.	Check for loose connections and proper pin alignment/engagement on the control's plug P9, Comm. board JP6 + J1, and the back of the display circuit board.	Check for continuity on the wire harness from the display to the communications board and Comm. board to control module. See repair parts section for proper replacement part.
		Cycle power off and on using boiler power switch and check for operation.	Replace with new display module. See repair parts section for proper replacement part.
	or Display contrast needs to be adjusted.	Look at the screen from other angles.	Power cycle the boiler, wait about 45 seconds then Press and hold the Enter button. While holding the Enter button, tap the up or down buttons to adjust the contrast level. If this does not work replace display.
TEMP RISE TOO QUICKLY	Occurs if supply water temperature in heat exchanger rises faster than 2° F per second during the first two minutes the burner is on.	Automatically resets after 1 minute delay or using manual reset on display.	Verify water pipe is installed correctly per instructions in this manual.
		Manual reset is necessary after 5 automatic resets have occurred during the same Priority heat demand. Reset using manual reset screen on display.	Verify proper circulator and speed for boiler size and system requirements.
			See message displayed TEMPERATURE SENSOR and follow procedure for loose connections.
DISPLAY COMM Fault	Occurs if display communications out for 30 seconds.	Automatically resets when communication is re-established.	Improper connections may display the incorrect model numbers. Check for a loose connection at the molex plug on the control and Comm. board, and connection on the back of the display.
Hardware Fault	Occurs when micro-controllers on main board have a RAM or ROM error, or communication is cut off.	Check for hardware damages.	RAM or ROM errors can be reset with the manual reset option. If problems persist, replace main board.



Troubleshooting *(continued)*

Figure 101 Troubleshooting suggestions for EVG boilers — Fault displays, diagnostics and corrective actions

Display	Condition	Diagnostics	Corrective Action(s)
LOW WTR CUTOFF OPEN	Occurs if internal low water cutoff contacts open.	Automatic reset occurs if contacts are open at least one second, but less than 5 seconds. Manual reset of control if contacts are open longer than 5 seconds.	Check for low water condition in system. Repair system as necessary refer to piping section of this manual. If low water condition does not exist, check Diagnostics — Inputs screen to view status of Low Water Cutoff. If shown as OPEN check wiring between LWCO and control. If wiring is alright, remove LWCO and Clean probe. If problem still exist, then replace the LWCO.
SUPPLY 58° F > RETURN	Boiler Out temperature has exceeded the Boiler In temperature by more than 58° F.	Automatically resets after 30 second delay when conditions no longer exist or using manual reset on display.	Verify water pipe is installed correctly per instructions in this manual. Verify proper circulator and speed for boiler size and system requirements. See message displayed TEMPERATURE SENSOR and follow procedure for loose connections.
RETURN > SUPPLY	Occurs if a return water temperature is greater than the corresponding supply temperature by 10° F or more.	Automatically resets when condition no longer exists.	Verify proper flow direction of the boiler circulator. Verify proper placement of system sensors for single or multiple boiler system. System sensors should be on system piping not on the boiler loop. Verify sensors are wired to correct terminal locations. System sensors may need to be located further away from the boiler loop connection to the system, if proximity to the boiler loop is causing sensors to be heated inaccurately.
SUPPLY WATER TEMPERATURE TOO HIGH	Occurs when the System Supply temperature goes above 200° F when the burner is running.	Automatically resets when Supply temperature goes below 200° F.	Verify proper flow direction of the system circulator. This circulator must be installed to push water through the system.
TEMPERATURE SENSOR FAULT	Occurs if a temperature sensor has electrically shorted (SHORT) or has become disconnected (OPEN).	Will automatically reset if the condition clears.	Check all the temperature readings of the boiler on the DIAGNOSTICS - TEMPERATURES menu to determine if any sensors are currently displayed as SHORT or OPEN. Compare this to the boiler temperatures recorded in the DIAGNOSTICS - ERRORS - LOCKOUT HISTORY # - TEMPERATURES during the last several lockout conditions. Determine which sensors are suspect and measure their resistance value and compare it to the values shown in Figure 95, page 108. If the resistance values are incorrect replace the temperature sensor. Refer to repair parts section for proper part number. Check wire harness for loose connections and pin engagement at sensor connection, chassis mount connection through control housing, and the control. Unplug connection at sensor and at control and check continuity between ends. If problem persists after checking items above, replace control. Refer to repair parts section for kit number.
	Occurs if dual temperature sensors values have spread by more than 10° F if the burner is on.	Automatically resets when sensors are within 10° F.	Follow procedure for above for SHORT and OPEN sensor conditions to properly diagnose sensor. If measured resistance values of sensors convert to temperatures separated by more than 10° F replace the sensor.
FLUE TEMP TOO HIGH	Occurs if flue temperature sensor exceeds 210° F (Warning) or 220° F (Lockout).	Automatic reset occurs if temperature drops below 210° F for 2½ minutes. Manual reset is required if the temperature rises above 220° F. Reset using manual reset screen on display.	Follow procedure for above for SHORT and OPEN sensor conditions to properly diagnose sensor. In addition inspect heat exchanger combustion chamber and flueways for abnormal wear or buildup. Inspect vent system for abnormal wear or damage. Contact Weil-McLain Technical Support.



Troubleshooting *(continued)*

Figure 102 Troubleshooting suggestions for EVG boilers — **Fault displays, diagnostics and corrective actions**

Display	Condition	Diagnostics	Corrective Action(s)
LIMIT OPEN	Occurs if manual or automatic reset limit opens.	Automatic external limit will reset 2½ minutes after external limit device closes.	Is there an external safety device connected? If yes, trouble shoot the external limit to determine and correct the cause that opened the limit. Also check for loose wiring connections.
		Manual limit fault must be reset by choosing Manual Reset on the display.	Inspect the connector on the control module plug P13. Ensure a jumper is installed across the MAN LIMIT (Pins 1 & 2) terminals if not using a manual reset external limit. Ensure a jumper is installed across the AUTO LIMIT (Pins 3 & 4) terminals if not using a automatic reset external limit.
HIGH TEMP LIMIT	Boiler temperature sensor reached High Temp Limit setting (no higher than 200° F).	Reset using manual reset screen on display.	Verify that high limit setting is at least 10° F above the <u>maximum</u> target temperature <u>plus the off differential</u> .
			Verify all isolation valves are open and circulators are programmed into the control properly.
			The boiler circulator output and System Pump/Aux. output can be configured to turn on or off with each priority. Refer to the Control Setup section to configure these properly for the system.
			Verify water pipe is installed correctly per instructions in this manual.
			Verify proper circulator sizing for boiler size and system requirements.
See message displayed TEMPERATURE SENSOR and follow procedure for loose connections.			
FLAME FAULT	Occurs if flame is detected when there should be no flame.	Reset using manual reset screen on display.	Burner may be operating too hot due to incorrect combustion. Inspect flame and conduct combustion test. Force boiler into high fire. Check flue gases with combustion analyzer and correct using the maintenance and startup procedure in this manual.
			Verify FLAME SIGNAL value quickly goes to zero on the DIAGNOSTICS - INPUTS screen when the gas valve closes.
			Check for flame at burner via flame current with burner off. Turn boiler off and watch flame through observation port. If flame continues after shut down replace gas valve.
GAS VALVE FAULT	The control has detected a problem with gas valve output circuit.	Control will do automatic retry; lockout if retry unsuccessful; retry 1 hour after lockout — restart if condition cleared, but lockout requiring manual reset if condition still present. Requires manual reset if control is in lockout.	If lockout reoccurs replace control.
BLOWER FAULT	Blower unable to reach required speed or does not reach 0 RPM when turned off.	Reset using manual reset screen on display; Control will check again after 1 hour and will automatically restart if condition is corrected.	Check wire harness for loose connections and pin engagement at blower connections, chassis mount connection through control housing, and control. Unplug connection at blower and at control and check continuity between ends. Blower is connected to both low voltage and line voltage harness.
			Check Diagnostics - Inputs screen with boiler in standby mode and blower not running. If BLOWER SPEED is not 0 RPM then replace blower.
			If blower does not rotate during ignition sequence check for 120V power at blower connection. If 120 VAC power at blower motor and it doesn't start replace blower. Check power at control. If 120VAC is not present at control when boiler is powered replace Control. Refer to repair parts section.



Troubleshooting *(continued)*

Figure 103 Troubleshooting suggestions for **EVG** boilers — **Fault displays, diagnostics and corrective actions**

Display	Condition	Diagnostics	Corrective Action(s)
IGNITION FAULT	Boiler went through 5 ignition attempts and never detected flame or flame sense value never reached minimum threshold for boiler model.	Automatically resets after 1 hour or can be reset by performing manual reset on boiler.	Check condensate trap for blockage allowing condensate to accumulate inside heat exchanger. Check ignition cable connection.
			Fouled, worn, bent, or faulty igniter. Fouled igniters can be cleaned for additional use with steel wool. Worn or badly fouled igniters should be replaced with the proper repair part. Igniter rods should be parallel with a 3.5mm (0.138 in) spark gap EVG 70/110 or 4.8mm (0.189 in) spark gap on EVG 155.
			NOTICE: Thin white deposits on the igniter are typical, but brown or black deposits could be the result of flue gas recirculation. Thoroughly inspect the venting system and termination for the possibility of leakage or flue gas feedback into the air line.
			Dirty burner and/or heat exchanger will cause high back pressure and poor ignition. Follow procedure in maintenance section of this manual to clean burner and heat exchanger. Visual inspection of flueways may not be sufficient to diagnose condition.
			Check combustion settings on high and low fire and adjust per setup instructions if necessary.
			Check incoming gas pressure with boiler off and at high fire. Adjust within limits on rating label.
			Verify correct boiler model is selected in control and high altitude is selected for installations 5,500 above sea level.
			Check ignition cable resistance. Should measure 1000 Ohms (+/- 50 Ohms).
			Check for flue pipe and intake pipe restrictions or blockage.
Check burner fasteners and gaskets.			
Check venturi gaskets and proper venturi. (Propane models use different venturi's).			
OUTDOOR SENSOR ERROR	Outdoor temperature sensor short or OPEN.	Will automatically reset if the condition clears. Warning only. Supply Max is targeted until ODT is restored, if used for target adjustment.	Determine which sensors are suspect and measure their resistance value and compare it to the values shown in Figure 95, page 108. If the resistance values are incorrect replace the temperature sensor. Refer to repair parts section for proper part number.
			Check wire harness for loose connections and pin engagement at sensor connection, chassis mount connection through control housing, and the control. Unplug connection at sensor and at control and check continuity between ends. If problem persists after checking items above, replace control. Refer to repair parts section for kit number.
AIR PRESSURE Switch Open	Occurs when Air Pressure connection is open.	Reset using Manual Reset screen on display.	Check boiler size selected in control against boiler rating label. Correct if necessary to select the proper boiler size.
			Check the factory jumper on P7 connection as seen on Figures 63, page 63 & Figure 64, page 64.
Closure Switch fault	Proof of Closure connections on P7 Pins 2 and 3 are open.	Soft lockout for 3½ minutes boiler retries. Each consecutive failure adds 1 minute to lockout time, up to 6½ minutes maximum.	None - Check jumper on correct pins and secure connection. Flow switch attached - Check correct pump is on, check wiring to flow switch and check switch is closing. CAD - Check voltage to damper. Check damper is opening.



Maintenance

⚠ WARNING DO NOT SERVICE THE BOILER WITHOUT A Evergreen® MAINTENANCE KIT AVAILABLE

The maintenance kit includes components that may have to be replaced when accessing or disassembling parts of the boiler.

Failure to replace damaged components and to use only the parts specifically intended for the boiler can result in severe personal injury, death or substantial property damage.

See Figure 111, page 127 for part number.

Disconnect power

⚠ WARNING Electrical shock hazard — Disconnect all electrical power to the boiler before attempting maintenance procedures. Failure to complete could result in severe personal injury, death or substantial property damage.

Re-install boiler jacket door after startup or servicing

⚠ WARNING Reinstall boiler jacket door after start-up or servicing. The boiler jacket door must be securely fastened to the boiler to prevent boiler from drawing air from inside the boiler room. This is particularly important if the boiler is located in the same room as other appliances.

Inspect boiler jacket door gaskets on front of cabinet. Gaskets must be in good condition, with no tears or gaps. Replace if necessary.

Failure to keep the jacket door securely sealed and fastened could result in severe personal injury or death.

Start-up and check/out

⚠ WARNING Removing and reinstalling components can change boiler behavior. After any maintenance procedure, you must prove the boiler is operating correctly. To do so, follow the complete procedure for boiler and system start-up, beginning on page 91. Failure to comply could result in severe personal injury, death or substantial property damage.

Oiled bearing circulators

1. Check circulators in the system. Oil any circulators requiring oil, following circulator manufacturer's instructions. Over-oiling will damage the circulator.

Cleaning the heat exchanger WATER SIDE, when required

1. Isolate the boiler from the heating system.
2. Obtain Sentinel X400 cleaner from Weil-McLain. Follow instructions supplied with the cleaner to clean the boiler heat exchanger.

⚠ WARNING Use ONLY the cleaning product available from Weil-McLain, Sentinel X400. See the Repair Parts section at the end of this manual for ordering information.

Using other cleaning materials or methods could cause permanent damage to the boiler heat exchanger.

⚠ WARNING Inspect the heating system water. If there is evidence of sediment or corrosion, the boiler must be isolated from the system. The system must then be thoroughly cleaned to remove all sediment.

Isolated the cause of the system corrosion and correct the problem(s) before placing the boiler back in service.

Failure to comply could result in severe personal injury, death or substantial property damage.



Cleaning heat exchanger flue side, 70

Cleaning the EVG 70 heat exchanger FLUE SIDE or accessing the burner, if required

⚠WARNING The boiler contains ceramic fiber materials. Use care when handling these materials per instructions on page 101 of this manual. Failure to comply could result in severe personal injury.

Tools required

- Long-handled Torx driver, #20
- Phillips head screwdriver, #2
- Nut driver, 5/16"
- Torque wrench
- Putty knife
- Wrench or socket, 10mm
- 3mm Allen wrench
- (2) Large Crescent wrenches

Before proceeding:

1. Shut down the boiler:
 - a. Follow “To Turn Off Gas to Appliance” instructions on boiler and Operating instructions.
 - b. Close the boiler manual gas valve.
2. Allow time for the boiler to cool to room temperature if it has been firing.
3. Remove jacket door by removing top retaining screw and undoing the two (2) latches on each side.
4. Rotate and lift the jacket door away from the boiler to remove.

Remove components to allow access

1. See Figure 105, page 118 part A to locate components referenced in the following.
2. Disconnect the communication board terminal strip and 4-pin connector from communication board and lift up and remove display bracket.
3. Remove the air baffle (item 28, page 3) by removing the two (2) hex head screws in front of the air intake adapter (item 16 page 3). Set aside.
4. See Figure 105, page 118 part B.
 - a. Pull the silencer straight forward until it snaps free of the blower housing. Set the air silencer aside. Rotate the air inlet silencer if needed to clear as it is removed.
 - b. Remove the gas valve retainer clip (item 4) and set aside. Pull the gas valve slightly to the right until it disengages from the venturi (item 5).

⚠WARNING Support the gas valve. DO NOT allow it to hang from the gas valve flex line. Make sure the gas valve-to-venturi O-ring (item 5, Figure 12, page 16) remains on the gas valve sleeve.

- c. Disconnect the blower end of the gas valve sense line (item 8).
- d. Remove the blower retainer clip (item 15). Set aside.
- e. Remove the blower by pulling down. Disconnect the two blower wiring harnesses on the back side of the blower.

Figure 104 Legend for Figure 105, page 118

A Boiler interior	6 Heat exchanger cover plate
B Boiler interior, with components disconnected to allow removal of combustion chamber cover plate	7 Ignitor assembly
C Combustion chamber cover plate and components removed from boiler	8 Gas valve sense line
D Disassembling to access the burner	9 Combustion chamber cover plate retainer nuts (4)
E Heat exchanger interior	10 Burner
1 Inlet air silencer	11 Putty knife
2 Blower assembly	12 Refractory
3 Gas valve	13 Burner gasket
4 Gas valve retainer clip	14 (3) Burner retainer screws
5 Venturi assembly	15 Blower retainer clip
	16 Control module

⚠CAUTION Label all wires prior to disconnection when servicing controls. Wiring errors can cause improper and dangerous operation.

- f. Remove the four (4) 10mm hex nuts (item 9) that secure the heat exchanger cover plate (item 6).
- g. Disconnect the ground wire and ignition cable from the igniter (item 7).
- h. Lift the cover plate/burner assembly vertically until the refractory (part C, item 12) clears the heat exchanger.
- i. Tilt the cover plate/burner assembly slightly forward. Then pull the assembly forward and out of the jacket.
- j. Remove the igniter by removing the two (2) Socket head Allen igniter bolts. Set the igniter, its gasket and screws aside. Be careful when handling the igniter not to damage the igniter ceramic.
- k. Inspect the igniter ceramic and electrodes. Clean the electrodes carefully with steel wool. If the igniter ceramic is cracked or damaged, replace the igniter with a new one.

⚠WARNING Handle the cover plate/venturi/burner assembly carefully to avoid damage to the igniter or refractory. Place the assembly on a clean, flat surface with the assembly upside down, as shown in Figure 105, page 118 part C and part D.

4. See Figure 105, page 118 part C.
 - a. Use a wide-blade putty knife (item 11) to gently pry the refractory from the heat exchanger cover plate. The refractory is attached with silicone adhesive and should separate with a little pressure on the putty knife.

⚠WARNING DO NOT gouge or crack the refractory. The refractory is made of ceramic fiber materials. Read the ceramic fiber WARNING on page 101 before handling or disposing of ceramic fiber materials.

Cleaning heat exchanger flue side, 70 (continued)

Figure 105 Accessing the burner or heat exchanger (see Legend on page 117)

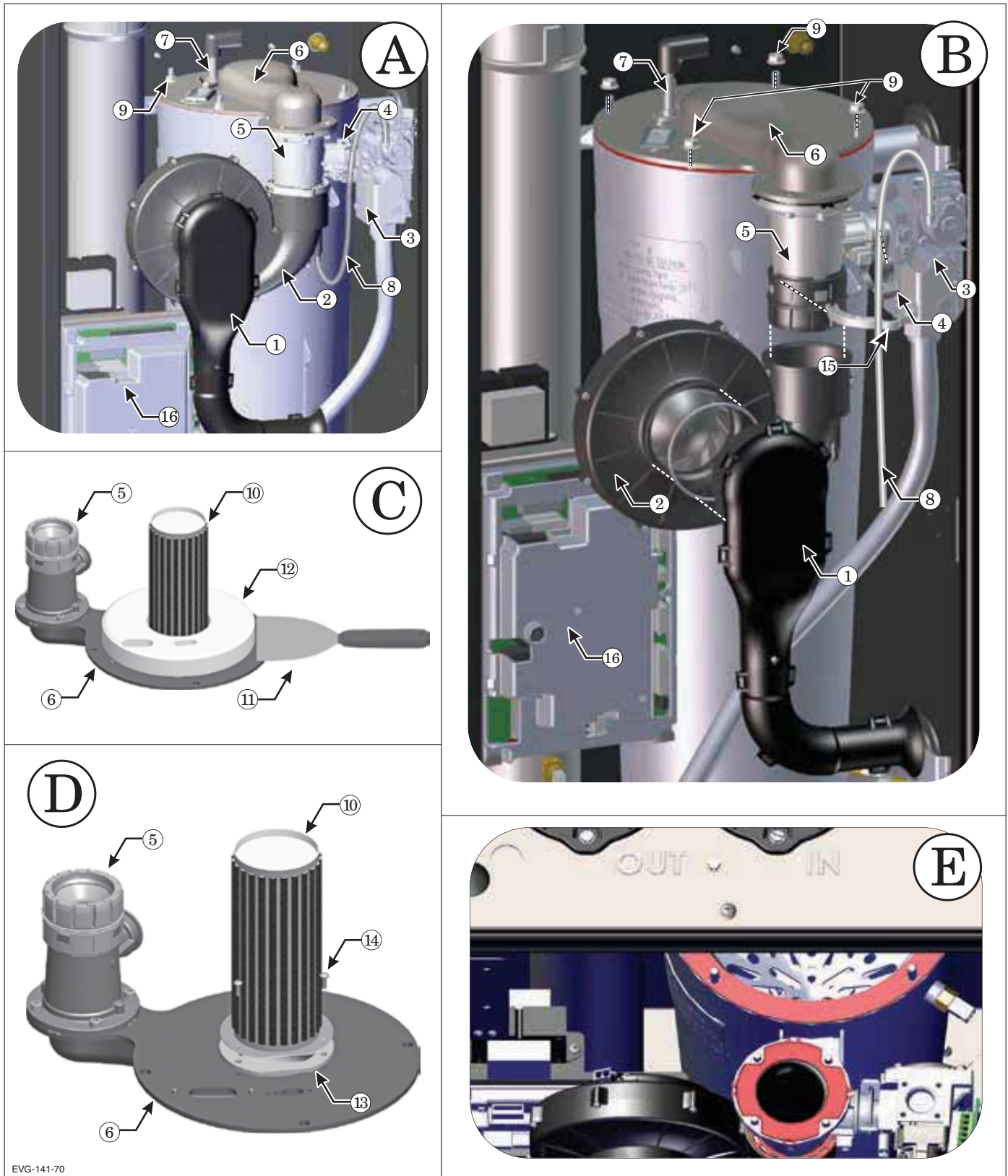

EVG-141-70



Cleaning heat exchanger flue side, 70 *(continued)*

Inspect and clean the burner

1. See Figure 105, page 118 part D.
 - a. Slide the refractory (item 12) over the burner and off. Set the refractory aside where it will be kept clean and protected from damage. If the refractory is damaged, it must be discarded and replaced with a new one.
 - b. Remove the three (3) #20 Torx screws (item 14) securing the burner (item 10) to the cover plate. Set aside.
 - c. Remove the burner and its gasket (item 13).
 - d. Inspect the interior of the burner. Brush and vacuum the interior if needed to remove lint or sediment. Alternative cleaning methods: • blow air from the inside out; • clean with a water spray from inside the burner; • swirl the burner thoroughly in a bucket of mild liquid laundry detergent water, then rinse thoroughly.
 - e. Inspect the burner exterior. It must be in good condition, with no visible damage.
 - f. Inspect the burner gasket. If the gasket is damaged, obtain a new gasket before re-installing the burner.
3. Reinstall the burner (item 10) and burner gasket (item 13) on the cover plate (item 6). Tighten the burner screws (item 14) using a torque wrench. The screws must be secure, but the torque must not exceed 20 inch-pounds.
4. Apply a ring of silicone adhesive on the cover plate (to secure the refractory).
5. Slide the refractory (item 12) over the burner. Align the refractory and press in place.
6. **Before** handling the assembly, allow the adhesive to set enough that the refractory is firmly held in place.
7. Reinstall the igniter assembly (item 7).
 - a. The igniter gasket must be intact and in good condition. Replace with a new gasket if necessary.
 - b. Insert the igniter into the cover plate opening, with the gasket in position.
 - c. Reinstall the two (2) Socket head Allen bolts finger tight.
 - d. Use a torque wrench to tighten the igniter bolts. DO NOT exceed 20 inch-pounds torque.
8. Reinstall the venturi/cover plate assembly (items 5 and 6) and secure the cover plate with 10mm hex nuts (item 9).

Inspect and clean the heat exchanger

1. Access the heat exchanger interior by following the previous instructions.
2. See Figure 105, page 118 part E.
3. Before using water to clean the heat exchanger, remove the control module (item 16). Label wires if they are not labeled. Set aside. Remove all connectors and wire harnesses from the control module and then remove the two (2) screws securing it to the bracket.
4. Use a strong light to visually inspect the interior of the heat exchanger. Make sure the flueways (tubes) are clear and unobstructed.
5. Use a vacuum cleaner to remove any accumulation on the heating surfaces. This includes removing any pieces of refractory that may have dropped into the exchanger.

▲WARNING DO NOT use any solvent when cleaning the exchanger.

6. If the vacuum cleaner is unable to clean completely, wash the heating surfaces with clean, warm water.
 - a. Place a shallow pan under the boiler condensate drain connection.
 - b. Loosen and move the condensate bracket, then loosen the condensate trap upper nut and slide the trap off of the drain connection. (See Figure 59, page 53 for reference.)
 - c. Spray fresh water into the heat exchanger and tubes to remove sediment. Collect water in the pan below.
7. Inspect the heat exchanger cover plate refractory. Replace if insulation is damaged.

Reinstall components

1. See Figure 105, page 118 for reference.
2. Reinstall the control module (item 16) to the control bracket and reconnect all connectors and wire harnesses.

▲WARNING You must gradually tighten the cover plate nuts using a torque wrench. The final torque MUST NOT exceed 45 inch-pounds. Alternate tightening until all nuts reach 45 inch-pounds.

9. Reconnect the ignition cable and the igniter ground wire.
10. Reinstall the blower (items 2).
 - a. Reconnect the two (2) blower wiring harnesses.
 - b. Slide the blower up onto the venturi sleeve.
 - c. Reinstall the blower retainer clip, item 15.
11. Reinstall the air inlet silencer (item 1) by pressing onto the air inlet adapter. Rotate into the normal vertical position (see part A) of Figure 105, page 118.
12. Slide the gas valve (item 3) outlet collar into the venturi (item 5) opening. Make sure the gas valve-to-venturi O-ring (item 5, Figure 12, page 16) is in place and in good condition. Inspect the gas valve flex line, making sure there are no signs of wear or damage. Replace if necessary.
13. Slide the gas valve retainer clip (item 4) into position to secure the gas valve.
14. Reinstall the condensate trap and bracket on the boiler condensate drain connection, if removed. (See Figure 59, page 53 for reference).

▲WARNING Perform a complete start-up procedure when putting the boiler back into service. See page 91 and all instructions for start-up and verification. Include a soap suds leak test on all interior and exterior gas piping after starting the boiler.



Cleaning heat exchanger flue side, 110

Cleaning the EVG 110 heat exchanger FLUE SIDE or accessing the burner, if required

⚠WARNING The boiler contains ceramic fiber materials. Use care when handling these materials per instructions on page 101 of this manual. Failure to comply could result in severe personal injury.

Tools required

- Long-handled Torx driver, #20
- T25 Torx Bit
- 3mm Allen wrench
- Phillips head screwdriver, #2
- Nut driver, 5/16"
- Torque wrench
- Putty knife
- Wrench or socket, 10mm
- (2) Large Crescent wrenches

Before proceeding:

1. Shut down the boiler:
 - a. Follow “To Turn Off Gas to Appliance” instructions on boiler and Operating instructions.
 - b. Close the boiler manual gas valve.
2. Allow time for the boiler to cool to room temperature if it has been firing.
3. Remove jacket door by removing top retaining screw and undoing the two (2) latches on each side. Rotate and lift the jacket door away from the boiler to remove.

Remove components to allow access

1. See Figure 107, page 121 part A to locate components referenced in the following.
2. Disconnect the communication board terminal strip and 4-pin connector from communication board and lift up and remove display bracket.
3. Remove the air baffle (item 28, page 3) by removing the two (2) hex head screws in front of the air intake adapter (item 16 page 3). Set aside.
4. See Figure 107, page 121 part B.
 - a. Release the air silencer bracket free from gas line.
 - b. Remove the air silencer from the venturi by sliding it away from the blower/venturi assembly. Set the air silencer aside.
 - c. Remove the two (2) electrical connectors from the blower and one connector from the gas valve.
 - d. By using two wrenches, loosen the union fitting between the flexible gas line and the gas valve flare adapter. Gently set the flex line aside, where it is out of the way and free from damage.
 - e. Remove the blower/venturi/gas valve assembly by removing the two (2) nuts connecting the blower to the cover plate.
 - f. Remove the four (4) 10mm hex nuts (item 8) that secure the heat exchanger cover plate (item 6).
 - g. Disconnect the ground wire and ignition cable from the igniter (item 7).

Figure 106 Legend for Figure 107, page 107

A Boiler interior	4 Venturi gas line clip
B Boiler interior, with components disconnected to allow removal of combustion chamber cover plate	5 Venturi assembly
C Combustion chamber cover plate and components removed from boiler	6 Heat exchanger cover plate
D Disassembling to access the burner	7 Ignitor assembly
E Heat exchanger interior	8 Combustion chamber cover plate retainer nuts (4)
1 Inlet air silencer	9 Burner
2 Blower assembly	10 Putty knife
3 Gas valve	11 Refractory
	12 Burner gasket
	13 (3) Burner retainer screws
	14 Control module

⚠CAUTION Label all wires prior to disconnection when servicing controls. Wiring errors can cause improper and dangerous operation.

- h. Lift the cover plate/burner assembly vertically until the refractory (part C, item 11) clears the heat exchanger.
- i. Tilt the cover plate/burner assembly slightly forward. Then pull the assembly forward and out of the jacket.
- j. Remove the igniter by removing the two (2) Socket head Allen igniter bolts. Set the igniter, its gasket and screws aside. Be careful when handling the igniter not to damage the igniter ceramic.
- k. Inspect the igniter ceramic and electrodes. Clean the electrodes carefully with steel wool. If the igniter ceramic is cracked or damaged, replace the igniter with a new one.

⚠WARNING Handle the cover plate/burner assembly carefully to avoid damage to the igniter or refractory. Place the assembly on a clean, flat surface with the assembly upside down, as shown in Figure 107, page 121 part C and part D.

4. See Figure 107, page 121 part C.
 - a. Use a wide-blade putty knife (item 10) to gently pry the refractory from the heat exchanger cover plate. The refractory is attached with silicone adhesive and should separate with a little pressure on the putty knife.

⚠WARNING DO NOT gouge or crack the refractory. The refractory is made of ceramic fiber materials. Read the ceramic fiber WARNING on page 101 before handling or disposing of ceramic fiber materials.



Cleaning heat exchanger flue side, 110 *(continued)*

Figure 107 Accessing the burner or heat exchanger (see Legend on page 120)

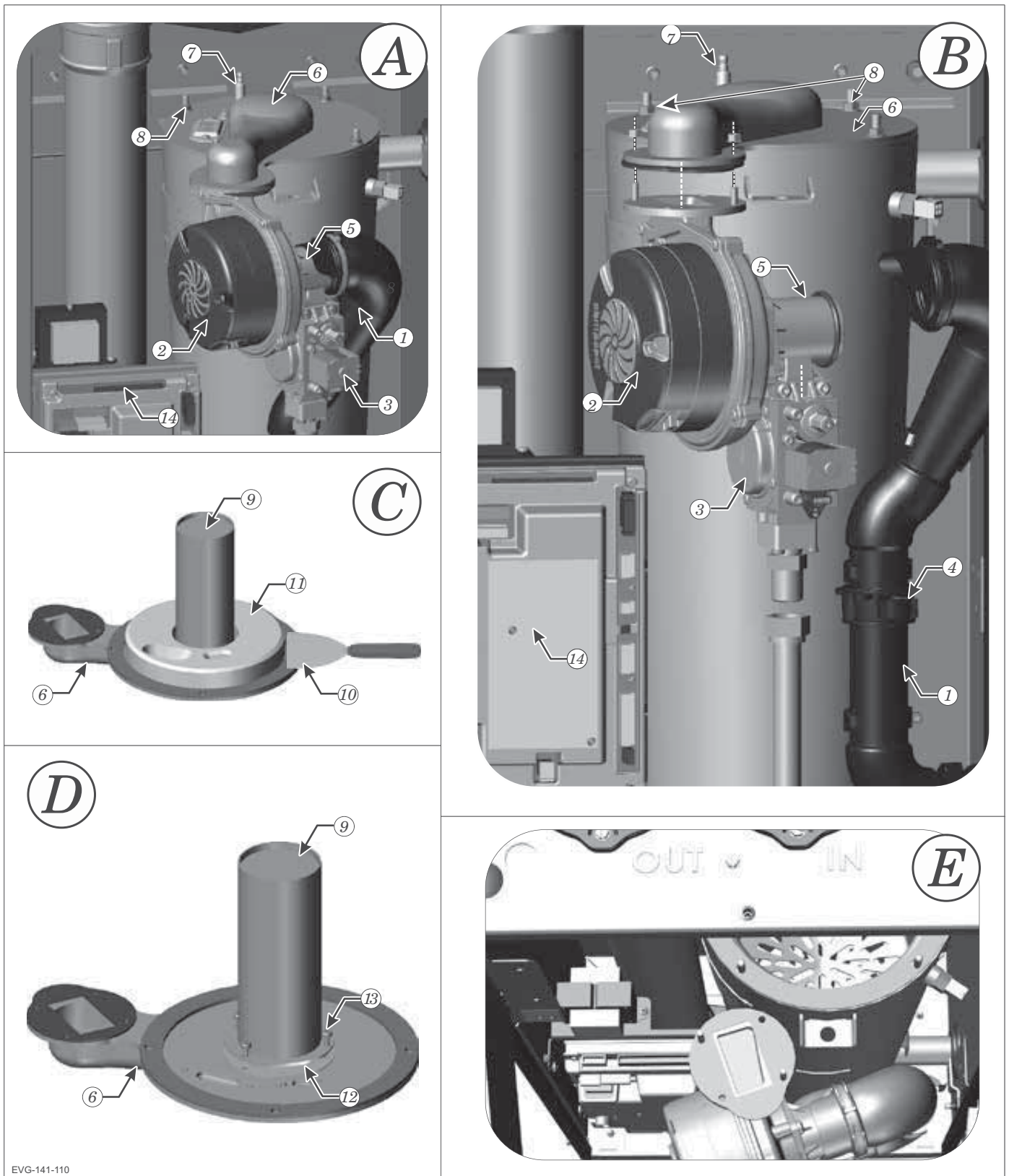

EVG-141-110



Cleaning heat exchanger flue side, 110 *(continued)*

Inspect and clean the burner

1. See Figure 107, page 121 part D.
 - a. Slide the refractory (item 11) over the burner and off. Set the refractory aside where it will be kept clean and protected from damage. If the refractory is damaged, it must be discarded and replaced with a new one.
 - b. Remove the four (4) #20 Torx screws (item 13) securing the burner (item 9) to the cover plate. Set aside.
 - c. Remove the burner and its gasket (item 12).
 - d. Inspect the interior of the burner. Brush and vacuum the interior if needed to remove lint or sediment. Alternative cleaning methods: • blow air from the inside out; • clean with a water spray from inside the burner; • swirl the burner thoroughly in a bucket of mild liquid laundry detergent water, then rinse thoroughly.
 - e. Inspect the burner exterior. It must be in good condition, with no visible damage.
 - f. Obtain a new burner gasket before re-installing the burner.

Inspect and clean the heat exchanger

1. Access the heat exchanger interior by following the previous instructions.
2. See Figure 107, page 121 part E.
3. Before using water to clean the heat exchanger, remove the control module (item 14). Label wires if they are not labeled. Set aside. Remove all connectors and wire harnesses from the control module and then remove the two (2) screws securing it to the bracket.
4. Use a strong light to visually inspect the interior of the heat exchanger. Make sure the flueways (tubes) are clear and unobstructed.
5. Use a vacuum cleaner to remove any accumulation on the heating surfaces. This includes removing any pieces of refractory that may have dropped into the exchanger.

▲WARNING DO NOT use any solvent when cleaning the exchanger.

6. If the vacuum cleaner is unable to clean completely, wash the heating surfaces with clean, warm water.
 - a. Place a bucket under the boiler condensate drain connection.
 - b. Loosen and move the condensate bracket, then loosen the condensate trap upper nut and slide the trap off of the drain connection. (See Figure 59, page 53 for reference.)
 - c. Spray fresh water into the heat exchanger and tubes to remove sediment. Collect water in the bucket below.
7. Inspect the heat exchanger cover plate refractory. Replace if insulation is damaged.

Reinstall components

1. See Figure 107, page 121 for reference.
2. Reinstall the control module (item 14) to the control bracket and reconnect all connectors and wire harnesses.
3. Reinstall the burner (item 9) and burner gasket (item 12) on the cover plate (item 6). Tighten the burner screws (item 13) using a torque wrench. The screws must be secure, but the torque must not exceed 20 inch-pounds.

4. Apply a ring of silicone adhesive on the cover plate (to secure the refractory).
5. Slide the refractory (item 11) over the burner. Align the refractory and press in place.
6. **Before** handling the assembly, allow the adhesive to set enough that the refractory is firmly held in place.
7. Reinstall the igniter assembly (item 7).
 - a. The igniter gasket must be intact and in good condition. Replace with a new gasket if necessary.
 - b. Insert the igniter into the cover plate opening, with the gasket in position.
 - c. Reinstall the two (2) Socket head Allen bolts finger tight.
 - d. Use a torque wrench to tighten the igniter screws. DO NOT exceed 20 inch-pounds torque.
8. Reinstall the cover plate assembly (items 5 and 6) and secure the cover plate with 10mm hex nuts (item 8).

▲WARNING You must gradually tighten the cover plate nuts using a torque wrench. The final torque MUST NOT exceed 45 inch-pounds. Alternate tightening until all nuts reach 45 inch-pounds.

9. Reconnect the ignition cable and the igniter ground wire.
10. Reinstall the blower, venturi, gas valve assembly.
 - a. Inspect the blower to cover plate gasket, replace if gasket is damaged or has taken a set.
 - b. Slide the blower assembly up to the cover plate, passing the two (2) blower studs up through the cover plate holes. Use the two locking nuts to secure the assembly, torx locking nuts to 20 inch-pounds.
 - c. Reinstall the flexible gas line by using two wrenches to tighten the union fitting between the gas line and the gas valve flare adapter.
11. Reinstall the air silencer (item 1).
12. Reinstall the two (2) electrical connectors from the blower and one connector from the gas valve.
13. Reinstall the condensate trap and bracket on the boiler condensate drain connection, if removed. (See Figure 59, page 53 for reference.)

▲WARNING Perform a complete start-up procedure when putting the boiler back into service. See page 91 and all instructions for start-up and verification. Include a soap suds leak test on all interior and exterior gas piping after starting the boiler.



Cleaning heat exchanger flue side, 155

Cleaning the EVG 155 heat exchanger FLUE SIDE or accessing the burner, when required

▲WARNING The boiler contains ceramic fiber materials. Use care when handling these materials per instructions on page 101 of this manual. Failure to comply could result in severe personal injury.

Tools required

- Metric wrench or socket, 10mm
- Phillips head screwdriver, #2
- Socket with 8" extension, 5/16"
- Torque wrench
- Putty knife
- 3mm Allen wrench
- (2) Large Crescent wrenches

Before proceeding:

1. Shut down the boiler:
 - a. Follow "To Turn Off Gas to Appliance" instructions on boiler and Operating instructions.
 - b. Close the boiler manual gas valve.
2. Allow time for the boiler to cool to room temperature if it has been firing.
3. Remove jacket door by removing top retaining screw and undoing the two (2) latches on each side.
4. Rotate and lift the jacket door away from the boiler to remove.

Remove and inspect the igniter assembly

1. See Figure 109, page 125 part A.
2. Disconnect the ground wire and ignition cable from the igniter (item 7).

▲CAUTION Label all wires prior to disconnection when servicing controls. Wiring errors can cause improper and dangerous operation.

3. Remove the two (2) Socket head Allen bolts securing the igniter to the heat exchanger cover plate (item 6).
4. Carefully slide the igniter out of its mounting slot.
5. Remove and inspect the igniter gasket. Replace with a new gasket if necessary.
6. Inspect the igniter ceramic and electrodes. Clean the electrodes carefully with steel wool. If the igniter ceramic is cracked or damaged, replace the igniter with a new one.

Remove components to allow access

1. See Figure 109, page 125 part A to locate components referenced in the following.
2. Disconnect the communication board terminal strip and 4-pin connector from communication board and lift up and remove display bracket.
3. Remove the air silencer and disconnect gas line:
 - a. See Figure 109, page 125 part A.
 - b. Locate the air silencer clip, item 8. Pull on the right side of the clip until it rotates forward as shown in part A inset.
 - c. Slide the air silencer (item 1) down and off of the venturi (item 5). Set the air silencer aside.
 - d. Disconnect the flexible gas line where it connects just below the gas valve (item 3). Lay the free end of the flexible gas line to the side.

▲WARNING Use two wrenches when disconnecting the flexible gas line to prevent damage to the gas valve and other gas line components.

- e. Disconnect the two wire harnesses connected to the blower and the wire harness connected to the gas valve.
3. It is RECOMMENDED to remove the blower/gas valve venturi assembly (item 2) from the cover plate (item 6) by removing the two 5/16" locknuts attaching them. This will make removing the cover plate significantly easier.
 4. Remove the heat exchanger cover plate assembly:
 - a. See Figure 109, page 125 part A, part C and part D.
 - b. Use a 10mm wrench to remove the five (5) M6 nuts (item 9) that secure the heat exchanger cover plate (item 6) to the heat exchanger.
 - c. Lift the cover plate assembly vertically until the refractory (part D, item 16) clears the heat exchanger.
 - d. Slide the cover plate forward as you tilt the front downward until the rear lip clears the cabinet. Avoid gouging the refractory on the heat exchanger studs.

▲WARNING DO NOT gouge or crack the refractory. The refractory is made of ceramic fiber materials. Read the ceramic fiber WARNING on page 101 before handling or disposing of ceramic fiber materials.

- e. Carefully place the cover plate assembly aside.

▲WARNING Handle the cover plate assembly carefully to avoid damage to the components or refractory. Place the assembly on a clean, flat surface.

Inspect and clean the burner

1. See Figure 109, page 125 part C and part D.
2. Use a Phillips screwdriver to remove the three (3) M4 screws and flat washers (item 10) that secure the burner access cover (item 4) to the heat exchanger cover plate (item 6).
3. Remove the burner cover plate (item 4) and the burner (item 11).
4. Remove the burner gasket (item 12) from the heat exchanger cover plate if still in place. This gasket is graphite and may pull apart or stick to the burner on removal. Replace the gasket with a new one during reassembly.
5. Inspect the burner access cover seal (item 13). Discard and use a new seal during re-assembly if the seal is damaged in any way.
6. Inspect the interior of the burner. Brush and vacuum the interior if needed to remove lint or sediment. Alternative cleaning methods: • blow air from the inside out; • clean with a water spray from inside the burner; • swirl the burner thoroughly in a bucket of mild liquid laundry detergent water, then rinse thoroughly.
7. Inspect the burner exterior. It must be in good condition, with no visible damage.
8. Clean the underside of the burner flange (see item 14) with a soft brush to remove any gasket fragments remaining.

Inspect refractory and replace burner gasket

1. See Figure 109, page 125 part B.
 - a. Inspect the refractory (item 15) to make sure it is intact, with no visible damage.
 - b. If the refractory must be replaced, use a wide-blade putty knife to gently pry the refractory from the heat exchanger cover plate. The refractory is attached with silicone adhesive and should separate with a little pressure on the putty knife.



Cleaning heat exchanger flue side, 155 *(continued)*

▲WARNING DO NOT gouge or crack the refractory. The refractory is made of ceramic fiber materials. Read the ceramic fiber WARNING on page 101 before handling or disposing of ceramic fiber materials.

- c. When replacing the refractory, apply a ring of silicone adhesive on the cover plate. Place the refractory onto the cover plate. Before handling the assembly, allow the adhesive to set enough that the refractory is firmly held in place.
2. Clean the burner gasket surface inside the heat exchanger cover plate (item 6) with a soft brush to remove any gasket residue.
3. The burner gasket must be replaced with a new one when the boiler is re-assembled after servicing.

Inspect and clean the heat exchanger

1. Access the heat exchanger interior by following the previous instructions. Remove and inspect the heat exchanger cover plate gasket. Replace if necessary.
2. See Figure 109, page 125 part E.
3. Before using water to clean the heat exchanger, remove the control module (item 17). Label wires if they are not labeled. Set aside. Remove all connectors and wire harnesses from the control module and then remove the two screws securing it to the bracket.
4. Use a strong light to visually inspect the interior of the heat exchanger. Make sure the flue ways (tubes) are clear and unobstructed.
5. Use a vacuum cleaner to remove any accumulation on the heating surfaces. This includes removing any pieces of refractory that may have dropped into the exchanger.

▲WARNING DO NOT use any solvent when cleaning the exchanger.

6. If the vacuum cleaner is unable to clean completely, wash the heating surfaces with clean, warm water.
 - a. Place a bucket under the boiler condensate drain connection.
 - b. Loosen and move the condensate bracket, then loosen the condensate trap upper nut and slide the trap off of the drain connection. (See Figure 59, page 53 for reference.)
 - c. Spray fresh water into the heat exchanger and tubes to remove sediment. Collect water in the bucket below.
7. Inspect the heat exchanger cover plate gasket (item 18). Replace if is damaged in any way.

Reinstall components

1. See Figure 109, page 125 for reference.
2. Reinstall the control module (item 20) to the control bracket and reconnect all connectors and wire harnesses.
3. Reinstall the burner (item 11), burner gasket (item 12) and burner access cover seal (item 13) on the heat exchanger cover plate (item 6).
 - a. Insert and tighten the burner cover plate screws and washers (item 10) using a Phillips screwdriver. The screws must be secure, with torque no more than 20 inch-pounds.
4. Reinstall the heat exchanger cover plate assembly on the heat exchanger.
 - a. Seat the heat exchanger cover plate gasket on the heat exchanger sealing surface.
 - b. Tilt heat exchanger cover plate front lip downward until back lip clears cabinet and burner can slide inside combustion chamber. Slide cover plate back and rotate until seated flat on the heat

Figure 108 Legend for Figure 109, page 125

A Boiler interior	8 Air silencer clip
B Assembled heat exchanger cover plate (item 6), burner (item 11), showing refractory (item 15)	9 Heat exchanger cover plate retainer nuts, (5)
C Disassembly of heat exchanger cover plate, burner and other components	10 Burner cover retainer (3) screws, M4 Phillips plus flat washers
D Burner assembly	11 Burner
E Heat exchanger interior	12 Burner gasket
1 Inlet air silencer	13 Burner access cover seal
2 Blower assembly	14 Burner sealing surface (lower surface of burner flange)
3 Gas valve	15 Refractory
4 Burner access cover	16 Cover plate gasket
5 Venturi assembly	17 Control module
6 Heat exchanger cover plate	18 Heat exchanger tube sheet
7 Igniter assembly	19 Heat exchanger outer shell

exchanger sealing surface. Avoid gouging the refractory on the heat exchanger studs.

- c. Secure the heat exchanger cover plate (item 6) to the heat exchanger with the five (5) M6 nuts using a 10mm wrench.

▲WARNING You must gradually tighten the cover plate nuts using a torque wrench. The final torque MUST NOT exceed 45 inch-pounds. Alternate tightening until all nuts reach 45 inch-pounds.

5. Reinstall the blower/gas valve/venturi assembly (items 2, 3, and 5).
 - a. Place blower flange on to studs protruding from cover plate.
 - b. Reinstall the two (2) 5/16" locknuts using a socket with extension.
 - c. Do not over tighten (torque no more than 20 inch-pounds).
6. Reinstall the igniter assembly (item 7).
 - a. The igniter gasket must be intact and in good condition. Replace with a new gasket if necessary.
 - b. Insert the igniter into the cover plate opening, with the gasket in position.
 - c. Reinstall the two (2) Socket head Allen bolts finger tight.
 - d. Use a torque wrench to tighten the igniter screws. DO NOT exceed 25 inch-pounds torque.
 - e. Reconnect the ignition cable and the igniter ground wire.
7. Reconnect the flexible gas line to the gas valve using two wrenches.
8. Reinstall the air inlet silencer (item 1) by pressing up onto the venturi (item 5). Rotate the air silencer clip (item 8) and snap it onto the gas line.
9. Reconnect the two (2) wire harnesses to the blower and gas valve.
10. Reinstall the condensate trap and bracket on the boiler condensate drain connection. (See Figure 59, page 53 for reference.)

▲WARNING Perform a complete start-up procedure when putting the boiler back into service. See page 91 and all instructions for start-up and verification. Include a soap suds leak test on all interior and exterior gas piping after starting the boiler.



Cleaning heat exchanger flue side, 155 (continued)

Figure 109 Accessing the burner or heat exchanger (see Legend on page 124)

	<p>⚠ WARNING Do NOT attempt to remove the burner from the heat exchanger cover plate without first removing the heat exchanger cover plate from heat exchanger. Damage to refractory will result. This damage is difficult to detect without the removal of the cover plate.</p>

EVG-141-155



Replacement parts

⚠ WARNING DO NOT SERVICE THE BOILER WITHOUT A MAINTENANCE KIT EVG AVAILABLE

The maintenance kit includes components that may have to be replaced when accessing or disassembling parts of the boiler. Failure to replace damaged components and to use only the parts specifically intended for the boiler can result in severe personal injury, death or substantial property damage. See Figure 111, page 127 for part number.

REPLACEMENT PART NUMBERS

Weil-McLain part numbers are found in this manual and in *Weil-McLain Boilers and Controls Repair Parts Lists*.

WHEN OPERATING THE BOILER ON PROPANE GAS

⚠ WARNING ALL Evergreen® boilers must be converted in order to operate with propane gas.

Figure 110 Propane conversion kits and instructions

Boiler model	Kit part number	Installation instructions
EVG 70	540-202-837	See page 15
EVG 110	540-131-088	See page 17
EVG 155	540-202-839	See page 19

⚠ WARNING Failure to adhere to these guidelines can result in severe personal injury, death or substantial property damage.

OBTAIN PARTS ONLY THROUGH WEIL-McLAIN

Replacement parts must be purchased through a local Weil-McLain distributor. When ordering, specify boiler model and size and include description and part number of replacement part. Results from using modified or other manufactured parts will not be covered by warranty and may damage boiler or impair operation.

THE BOILER CONTAINS CERAMIC FIBER MATERIALS

The boiler contains ceramic fiber materials. Use care when handling these materials per instructions on page 101 of this manual. Failure to comply could result in severe personal injury.

REINSTALL Jacket door

Inspect boiler jacket door gaskets on front of cabinet and reinstall boiler jacket door after start or servicing. The boiler jacket door must be securely fastened to the boiler to prevent boiler from drawing air from inside the boiler room. This is particularly important if the boiler is located in the same room as other appliances. Failure to keep the jacket door securely fastened could result in severe personal injury or death.

BEFORE SERVICING or MAKING CONNECTIONS —

ALWAYS TURN POWER OFF TO THE BOILER TO PREVENT ELECTRICAL SURGES, WHICH CAN DAMAGE BOILER COMPONENTS.

LABEL WIRES BEFORE REMOVING

⚠ CAUTION Label all wires prior to disconnection when servicing controls. Wiring errors can cause improper and dangerous operation.



Replacement parts *(continued)*

Figure 111 Miscellaneous parts and kits

Description	Part Number	Description	Part Number
CHEMICALS			
Antifreeze, Sentinel X500, 1 Gallon	592-900-029	Sidewall separate pipes vent/air termination kits (includes two cover plates)	
Corrosion inhibitor, Sentinel X100	592-900-002	Kit for 2" PVC vent and air pipes.	383-700-171
Sentinel X100 Quick Test Kit	592-900-005	Kit for 3" PVC vent and air pipes.	383-500-100
Cleaner, Sentinel X400	592-900-003	Kit for 3" AL29-4C SS vent pipe and PVC air pipe	383-700-172
BOILER ACCESSORIES			
EVG 70 maintenance kit — igniter, igniter gasket, venturi gasket, cover plate gasket, venturi-gas valve o-ring, refractory, silicone, inhibitor test kit, clips and manuals	383-700-165	PVC concentric vent kit — horizontal or vertical (includes components for concentric assembly)	
EVG 110 maintenance kit — igniter, igniter gasket, venturi gasket, cover plate gasket, venturi-gas valve o-ring, refractory, silicone, inhibitor test kit, clips and manuals	383-700-243	Kit for 2" PVC vent and air pipes.	383-700-167
EVG 155 maintenance kit — igniter, igniter gasket, venturi gasket, cover plate gasket, venturi-gas valve o-ring, refractory, silicone, inhibitor test kit, clips and manuals	383-700-200	Kit for 3" PVC vent and air pipes.	383-500-350
Condensate trap kit (supplied with boiler) — condensate trap assembly and flexible line	560-907-722	Bird screens (1 screen each)	
CONDENSATE HANDLING ACCESSORIES		For 2" PVC vent and air pipes	560-907-728
Condensate neutralizer kit	383-500-631	For 3" PVC vent and air pipes	383-500-105
VENT/AIR PARTS AND KITS (PVC or STAINLESS STEEL) available from Weil-McLain		VENT/AIR PARTS AND KITS (POLYPROPYLENE PIPE) available from M&G Simpson-Duravent ONLY	
Weil-McLain Direct Exhaust Venting Kit Includes interior/exterior intake/exhaust plates. 2" & 3" vent screens, templates and mounting hardware	383-500-778	M&G Simpson-Duravent PolyPro SIDEWALL concentric vent/air kit (color: white)	
Weil-McLain sidewall vent/air cap termination kit for PVC vent and air pipes Includes sidewall vent/air termination cap, inside and outside cover plates, and mounting hardware; openings are sized for 3" PVC pipe (requires field-installed 3 x 2 adapter if using 2" vent/air pipes)	383-500-397	2" polypropylene pipe	2PPS-HK
Weil-McLain sidewall vent/air cap termination kit for AL29-4C vent pipe and PVC air pipe Includes sidewall vent/air termination cap, inside and outside cover plates, and mounting hardware; openings are sized for 3" SS vent pipe and 3" PVC air pipe (requires field-installed 3 x 2 adapter if using 2" vent/air pipes)	382-200-430	3" polypropylene pipe	3PPS-HK
		M&G Simpson-Duravent PolyPro VERTICAL concentric vent/air kit; color = black (part number shown) or terra cotta (add -TC suffix)	
		2" polypropylene pipe	2PPS-VK
		3" polypropylene pipe	3PPS-VK
		M&G Simpson-Duravent PolyPro SIDEWALL separate air and vent pipes	
		2" polypropylene pipe	2PPS-HTP
		3" polypropylene pipe	3PPS-HTP
		M&G Simpson-Duravent PolyPro Polypropylene pipe appliance adapter 3"	3PPS-03PVC-3PPF
		VENT/AIR PARTS AND KITS (POLYPROPYLENE PIPE) available from Centrotherm Eco Systems ONLY	
		Centrotherm INNOFLUE SIDEWALL concentric vent/air kit	
		3" polypropylene pipe	ICWT352
		2" stainless steel/pp pipe	ICWS2413
		3" stainless steel/pp pipe	ICWS3513
		Centrotherm INNOFLUE VERTICAL concentric vent/air kit	
		2" polypropylene pipe	ICRT2439
		3" polypropylene pipe	ICRT3539
		Centrotherm INNOFLUE Polypropylene pipe appliance adapter 3" . .	ISAAL0303

Go to www.weil-mclain.com to locate Weil-McLain distributors



Replacement parts *(continued)*

Figure 112 Jacket parts — **EVG 70/110/155** (see Figure 113, page 129 for illustration)

Item	Name	Description / contents	Part Number
100	Jacket door	Jacket door and labels	383-900-101
110	Seals – jacket door to cabinet	Seals for front face of cabinet	383-900-102
120	Wall-mount bracket (wall side)	Bracket and hardware	383-800-218
130	Wall-mount hardware (boiler side)	Boiler mounting studs (bolts, washers, and spacers, 2 each)	383-800-219
140	Gaskets - upper panel to cabinet	Gaskets - upper panel to cabinet	383-800-220
150	Gasket - heat exchanger to bottom panel	Gasket - condensate trap to bottom panel	590-318-071
160	Door latch (2 required)	Includes rivets	383-700-122
170	Door retention screw	Screw Truss Head #10-24	562-150-290
180	Gasket - internal flue pipe to adapter	Gasket fits inner diameter of boiler flue pipe	590-318-051
190	Flue pipe adapter	Top flue adapter with internal gasket	560-907-719
200	Boiler flue pipe	Internal flue pipe and gasket	560-907-720
210	Air inlet adapter	Top air inlet adapter with internal gasket	560-907-718
220	Gasket - pipe adapter to cabinet	Gasket - pipe adapter to cabinet (applies to air and vent adapters)	590-300-031
230	Gasket - pipe adapter to system pipe	Gasket fits inner diameter of top adapter	590-318-052
240	Jacket bottom panel kit	Jacket bottom panel, gasket (items 150 and 240) and screws	383-900-103
250	Gaskets - bottom panel to cabinet	Gaskets - bottom panel to cabinet	383-900-104
260	Air baffle and screws	Air baffle and screws	383-800-223
270	Hole plug	Hole plug, 7/8", for sealing electrical knockouts	561-444-186
280	Pipe grommet	Seals water pipes to cabinet	562-248-740
290	Control/transformer bracket	Bracket to mount control module and transformer	383-800-228
300	Display board bracket	Mounting for the display to inside of cabinet	383-900-105
310	Display/bracket gasket		590-318-125
320	Display/door gasket		590-318-121
330	Condensate bracket 70/110 (not shown)	Bracket and plastic rivets	383-700-238
340	Condensate bracket 155 (not shown)	Bracket and plastic rivets	383-700-239
350	Floor stand assembly		383-900-106
360	Floor stand front panel		383-900-107
370	Boiler leg kit	Includes (4) leg leveling glides 5/16-18 nickel plated steel with polyethylene base	383-500-065
380	Bumpers	Stand-off .5 inches threaded #10-24	563-039-984
390	Shoulder screw	Screw shoulder 1/4" x 5/16 10-24 x 3/8 thread stainless steel	562-150-305

Go to www.weil-mclain.com to locate Weil-McLain distributors



Replacement parts *(continued)*

Figure 114 Heat exchanger parts **EVG 70/110** (see Figure 115, page 131 for illustration)

Item	Name	Part Number	Model 70	Model 110
100	Heat exchanger	383-800-234	●	—
		383-800-238	—	●
110	Heat exchanger, condensate dish, cover plate, burner, igniter, sight glass, refractory, water sensors, gaskets, silicone, and hardware (includes items 100, 120, 130, 140, 160, 180, 210, 240, and 260)	383-800-236	●	—
		383-800-239	—	●
120	Condensate dish, gaskets, and hardware	383-700-102	●	●
130	Gasket to seal heat exchanger to condensate dish	383-700-103	●	●
140	Gasket to seal condensate dish to internal flue pipe	383-700-104	●	●
150	Refractory insulation & silicone sealant	383-700-105	●	—
		383-700-244	—	●
160	Heat exchanger cover plate, refractory, silicone, and gaskets (includes items 150, 170, 200, 220, and 250)	383-700-108	●	—
		383-800-240	—	●
170	Cover plate gasket (exchanger to gasket)	383-700-109	●	●
180	Sight glass kit (bracket, glass, gaskets, and hardware) (includes items 190 and 200)	383-700-185	●	●
190	Sight glass	591-419-202	●	●
200	Sight glass gaskets, upper and lower	383-700-112	●	●
210	Igniter kit (igniter, gasket and screws)	383-700-113	●	—
		383-700-245	—	●
220	Igniter to cover plate gasket	590-300-034	●	●
230	Burner, gasket, and hardware (includes item 250)	383-700-106	●	—
		383-700-246	—	●
240	Burner gasket	383-700-107	●	—
		383-700-247	—	●
250	Heat exchanger water temperature sensor (one sensor for either boiler inlet or outlet water temperature)	511-724-296	●	●



Replacement parts *(continued)*

Figure 115 Heat exchanger assembly **EVG 70/110** (see Figure 114, page 130 for part numbers)

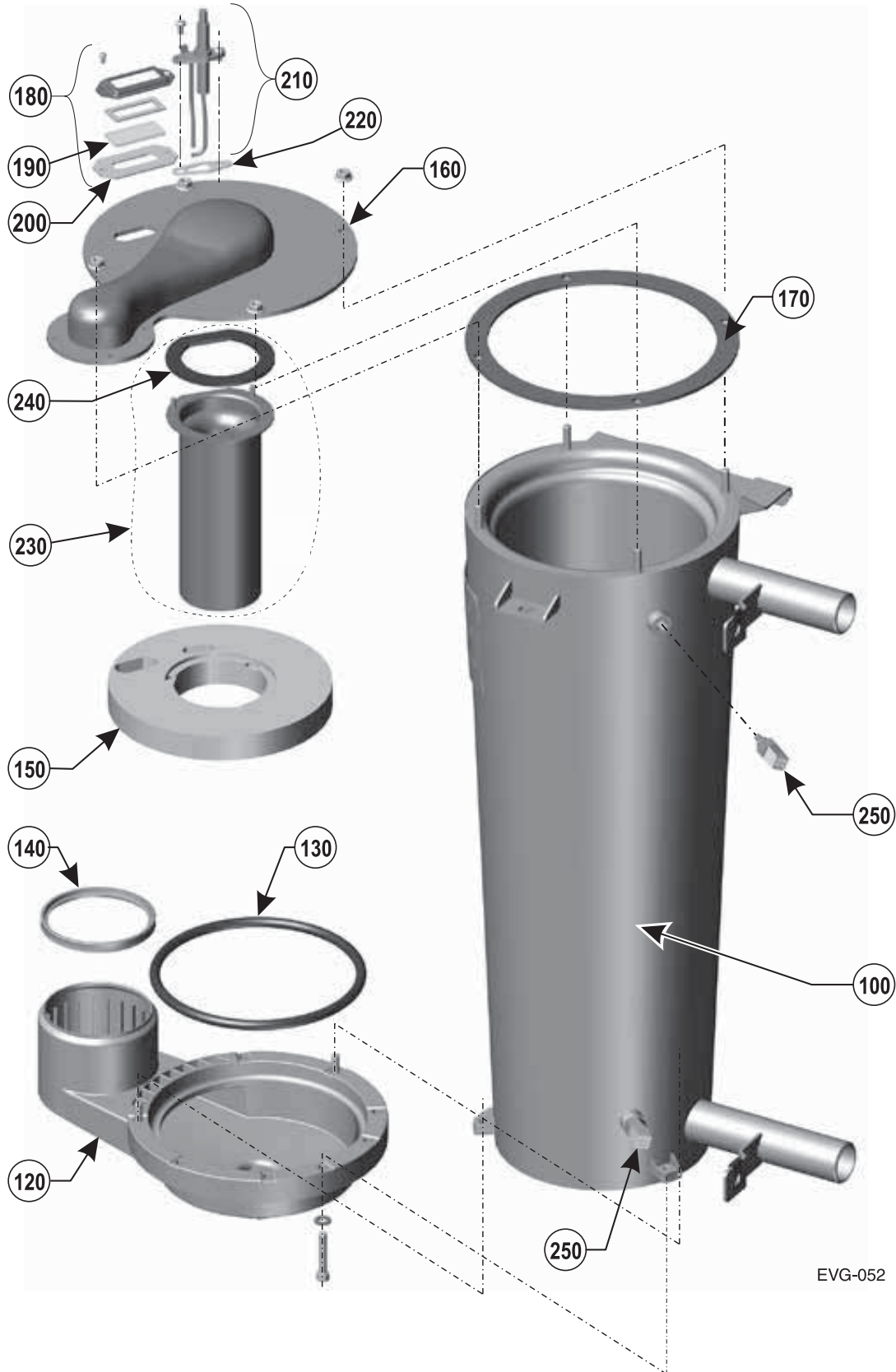

EVG-052

Go to www.weil-mclain.com to locate Weil-McLain distributors



Replacement parts *(continued)*

Figure 116 Heat exchanger parts **EVG 155** (see Figure 117, page 133 for illustration)

Item	Name	Part Number
100	Heat exchanger	383-800-231
110	Heat exchanger, condensate dish, cover plate, burner, igniter, sight glass, refractory, water sensors, gaskets, silicone, and hardware (includes items 100, 130, 140, 160, 170, 180, 190, 200, 210, and 270)	383-800-233
120	Cover plate/heat exchanger gasket	590-318-054
130	Boiler inlet temperature sensor	511-724-296
140	Boiler outlet temperature sensor (same as item 130)	
150	Blower gasket	590-318-006
160	Condensate dish, gaskets, and hardware	383-700-181
170	Gasket to seal heat exchanger to condensate dish	383-700-205
180	Gasket to seal condensate dish to internal flue pipe	383-700-104
190	Heat exchanger cover plate, refractory and gaskets (includes items 200, 230, 260, and 290)	383-700-184
200	Refractory insulation & silicone sealant	383-700-182
210	Burner, gasket, and hardware (includes item 220)	383-700-183
220	Burner gasket	383-700-208
230	Burner access cover, gasket and hardware (includes item 240)	383-700-202
240	Burner access cover gasket	383-700-206
250	Igniter kit (igniter, gasket and screws) (includes item 260)	383-700-187
260	Igniter gasket	590-300-034
270	Sight glass kit (bracket, glass, gaskets, and hardware) (includes items 280 and 290)	383-700-185
280	Sight glass	591-419-202
290	Sight glass gaskets, upper and lower	383-700-112
300	Heat exchanger cover plate gasket set (includes items 120, 150, 220, 240 and 260)	383-700-207



Replacement parts *(continued)*

Figure 117 Heat exchanger assembly **EVG 155** (see Figure 116, page 132 for part numbers)



EVG-152



Replacement parts *(continued)*

Figure 118 Combustion components for **EVG 70/110** (see Figure 120, page 135 for illustration)

Item	Name	Description / contents	Part Number	Model 70	Model 110
100	Relief valve	30 PSIG relief valve — shipped loose for field installation	383-500-095	●	●
110	Pressure & temperature gauge	Shipped loose for field installation	380-000-000	●	●
200	Air inlet silencer	Silencer	383-700-155	●	—
			383-700-248	—	●
210	Silencer o-ring	O-ring	590-318-049	●	—
220	Blower	Blower, clip and gasket	383-700-157	●	—
	Blower, venturi & gas valve assembly	Blower, venturi, gas valve and blower gasket	383-700-249	—	●
225	Blower, venturi & gas valve assembly	Blower, venturi, gas valve and blower gasket	383-700-249	—	●
230	Blower retainer clip	Clip	562-650-115	●	—
240	Reference tube	Tube to connect blower to gas valve	590-300-001	●	—
250	Gas valve/venturi assembly	Gas valve, venturi, gasket, o-ring, clip, and screws	383-700-159	●	—
	Gas valve	Gas valve, rubber boot, and screws	383-700-259	—	●
255	Rubber boot - gas valve/venturi	Gasket between gas valve and venturi	383-700-261	—	●
260	Gas valve retainer clip	Clip	562-650-116	●	—
270	Gas valve adapter block	Threaded block, o-ring, and screws	563-910-031	●	●
271	Gas flex line adapter	NPT to flare adapter	562-302-576	●	●
273	Adapter block O-ring	(10 O-rings) (not shown)	383-600-009	●	●
275	Gas valve outlet o-ring	O-ring	590-318-045	●	—
280	Propane orifice — boilers converted to propane ONLY — available only with propane conversion kit — see Figure 110, page 126 for information		—	—	—
290	Gas flex line	Gas line, seal, and hardware	383-800-224	●	—
			383-800-241	—	●
295	Gas pipe flange gasket	Gasket gas flex line to cabinet	590-300-027	●	●

Figure 119 Combustion components for **EVG 155** (see Figure 120, page 135 for illustration)

Item	Name	Description / contents	Part Number
100	Relief valve	30 PSIG relief valve — shipped loose for field installation	383-500-095
110	Pressure & temperature gauge	Shipped loose for field installation	380-000-000
270	Gas valve adapter block	Threaded block, o-ring, and screws	563-910-031
271	Gas flex line adapter	NPT to flare adapter	562-302-576
273	Adapter block O-ring	(10 O-rings) (not shown)	383-600-009
300	Air inlet silencer	Silencer with gasket and clip	383-700-203
310	Blower	Blower	383-700-195
320	Gas valve/venturi assembly	Gas valve, venturi, gasket and hardware	383-700-196
330	Propane orifice — boilers converted to propane ONLY — available only with propane conversion kit — see Figure 110, page 126 for information		—
360	Gas flex line	Gas pipe and hardware	383-800-241
370	Gas pipe flange gasket	Gasket, gas flex line to cabinet	590-300-027

Go to www.weil-mclain.com to locate Weil-McLain distributors



Replacement parts *(continued)*

Figure 120 Combustion components for **EVG 70/110 /155**(see Figure 118, page 134 for part numbers)

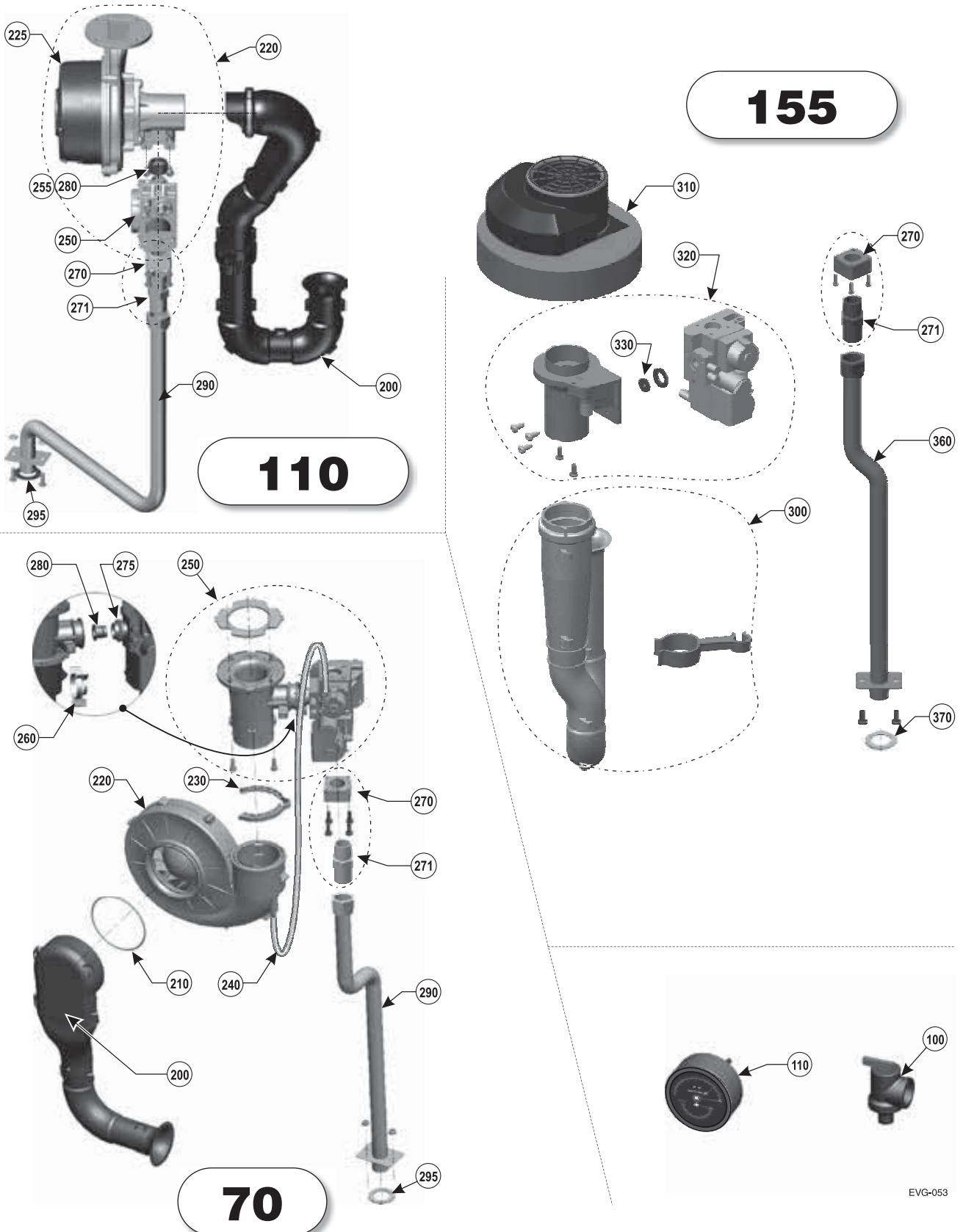

Go to www.weil-mclain.com to locate Weil-McLain distributors



Replacement parts *(continued)*

Figure 121 Controls and electrical components — **EVG 70/110/155** (see Figure 122, page 137 for illustration)

Item	Name	Description / contents	Part Number
100	Flue temperature sensor & grommet	One sensor & grommet	383-500-600
110	Grommet - Flue temperature sensor	One grommet	590-318-011
120	Outdoor temperature sensor	One sensor	510-312-218
130	System temperature sensor	One sensor	383-500-601
140	Low water cut-off		511-100-005
150	Transformer 120V/24V	50 VA transformer	383-500-628
160	Display board assembly	Includes circuit board and plastic housing	383-900-108
170	Control module assembly	Control module and housing	381-330-037
180	Communication board	One board	383-900-110
190	Wire harness — line voltage (not shown)	Wire harness (EVG 70)	591-392-047
		Wire harness (EVG 110)	591-392-044
		Wire harness (EVG 155)	591-392-043
200	Wire harness — low voltage (not shown)	Wire harness (EVG 70)	591-392-048
		Wire harness (EVG 110)	591-392-045
		Wire harness (EVG 155)	591-392-046
210	Wire harness — Low voltage communication board (not shown)	Connects communication board to control module	591-392-004
220	Wire harness — Communication Ethernet (not shown)		591-392-009
230	Ignition cable (not shown)	Ignition cable	591-392-012
240	F1 - 3 amp, fast blow ato (5 fuses) (not shown here — see Figure 96, page 108)	Five Fuses	383-500-603
250	F2 - 12 amp, fast-blow ag (5 fuses) (not shown here — see Figure 96, page 108)	Five Fuses	383-500-604
260	Jumper for low voltage terminal blocks (not shown)	Five Jumpers	383-500-641
270	Connector electrical control (not shown)	Includes 8 connectors	383-900-111
280	Low voltage sealed wire grommet (not shown)	Seals thermostat wire at entrance to cabinet	562-248-771
290	Communication board terminal block		512-050-248
300	Communication board standoffs	Includes 4 stand offs	383-900-112
310	Circulator Evergreen 70/110	007e	511-405-153
	Circulator Evergreen 155	0015e	511-140-155



Replacement parts *(continued)*

Figure 122 Controls and electrical assemblies — **EVG 70/110/155** (see Figure 121, page 136 for part numbers)

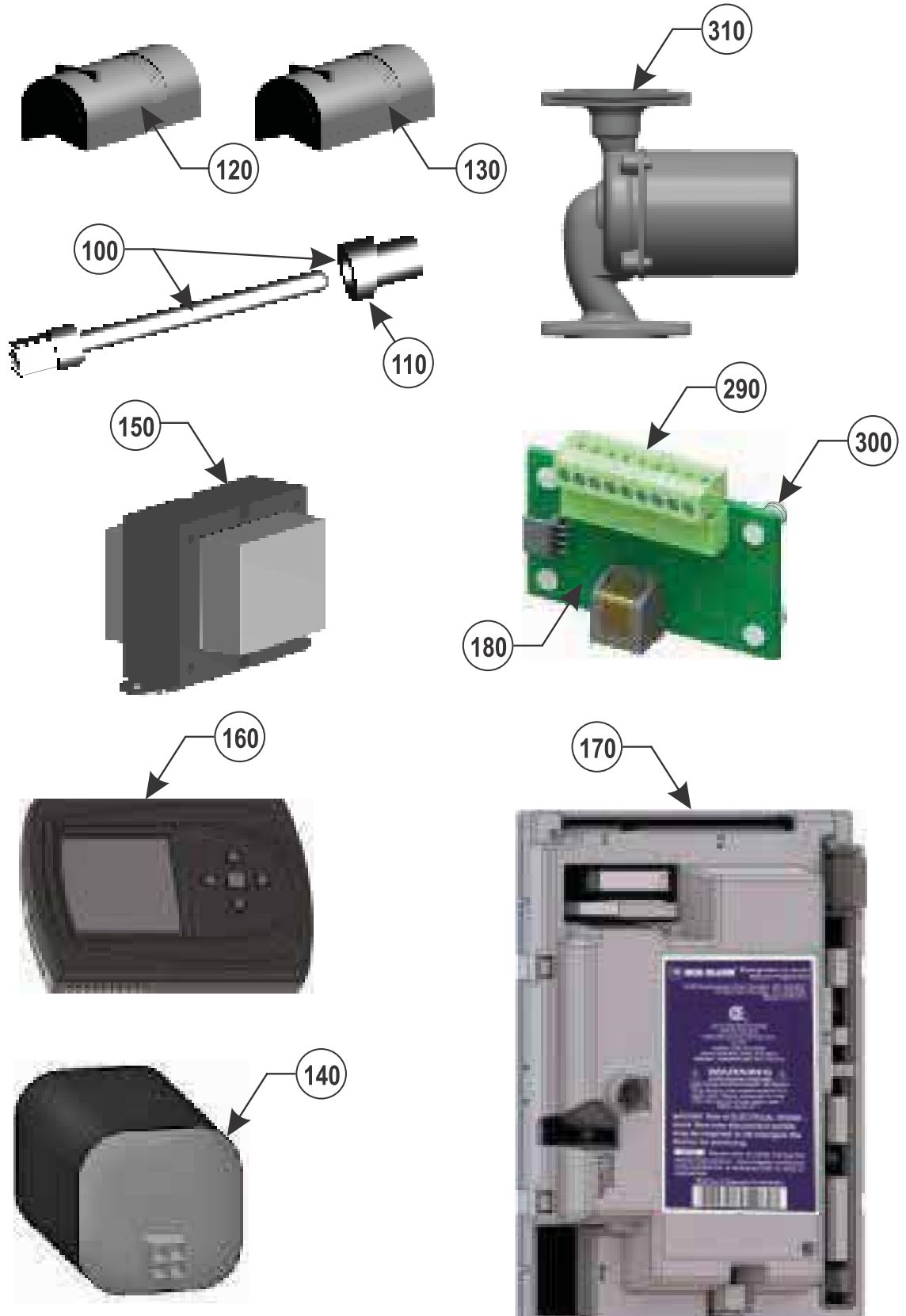

Dimensions

Figure 123 Dimensional data — Evergreen® 70/110/155 (all dimensions in inches)

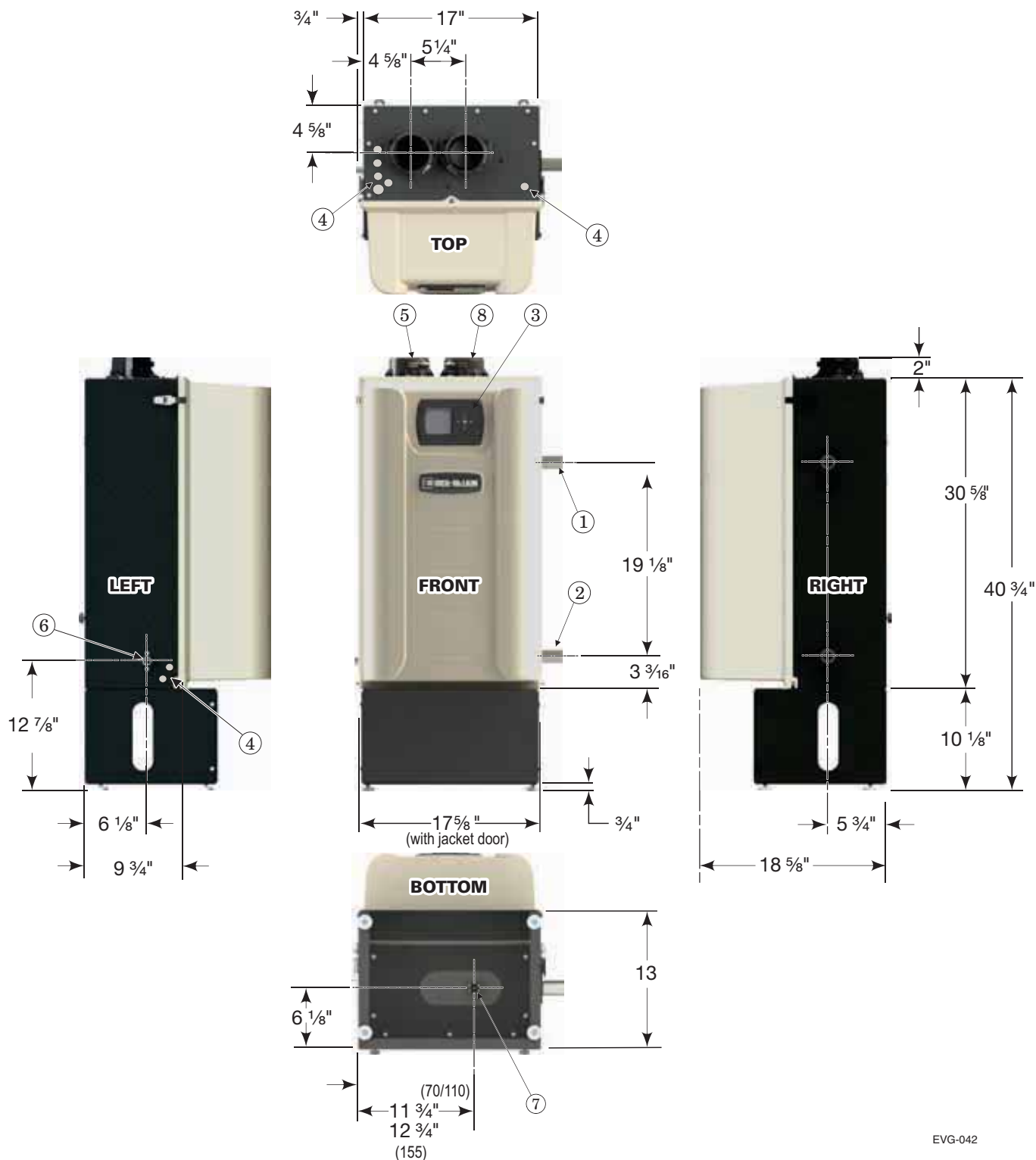

EVG-042

- | | |
|--|---|
| <ul style="list-style-type: none"> 1 Boiler supply tapping — 1" NPT -70/110, 1-1/4" NPT -155 2 Boiler return tapping — 1" NPT -70/110, 1-1/4" NPT -155 3 Control display and navigation buttons 4 Electrical entrance openings | <ul style="list-style-type: none"> 5 Vent connection: 3" PVC 6 Gas connection 7 Condensate trap nozzle 8 Air connection: 3" PVC |
|--|---|



Ratings — Evergreen® boilers

Figure 124 Ratings and engineering data — Evergreen® 70/110/155

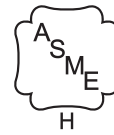

Boiler Model EVG	CSA Input	CSA Output / DOE Heating Capacity	Net AHRI Water Rating	DOE Seasonal Efficiency	Boiler Water Content	Vent/ Comb. Air Connection Diameter	% Input derate vs vent length (Values shown are at MAX vent/air pipe length — See Note 6) Direct Vent Venting ONLY			
							Natural gas		Propane	
							2" Vent/air piping	3" Vent/air piping	2" Vent/air piping	3" Vent/air piping
70	70,000	65,000	57	95.2	2.54	3" PVC	12 %	5 %	12 %	5 %
110	110,000	101,000	88	95.0	2.54	3" PVC	N/A	5 %	N/A	5 %
155	155,000	143,000	124	95.1	3.22	3" PVC	N/A	5 %	N/A	5 %

Notes

- As an Energy Star Partner, Weil-McLain has determined that Evergreen® 70, 110 and 155 boilers meet the Energy Star guidelines for energy efficiency. NOTE: Adjusting boiler firing rate will affect AFUE rating.
- Based on standard test procedures prescribed by the United States Department of Energy. Ratings also referred to as CSA Output. NOTE that only DOE Heating Capacity and AFUE are certified by AHRI. AFUE is also known as Annual Fuel Utilization Efficiency or Seasonal Efficiency.
- Net AHRI ratings are based on net installed radiation of sufficient quantity for the requirements of the building and nothing need be added for normal piping and pickup. Ratings are based on a piping and pickup allowance of 1.15. An additional allowance should be made for unusual piping and pickup loads.
- Evergreen® boilers must be direct-vented. Evergreen® boilers require special venting, consistent with Category IV boiler. Use only the vent materials and methods specified in this manual. Evergreen® boilers may be direct exhaust vented. Evergreen® 70 vent/air pipes can be either 2" or 3". Evergreen® 110 or 155 vent/air pipes must be 3".
- Ratings shown are for sea level applications only. For altitudes from sea level to 5,500 feet above sea level, the Evergreen® boiler requires no modifications and automatically derates itself by approximately 4% per 1000 feet above sea level.
- All of the boilers will automatically de-rate as vent/air pipe length increases, due to the pressure loss through the piping. For vent/air pipe lengths less than the maximum, the derate equals the value above (% Input derate vs. vent length) times vent length ÷ 100. All vent and air pipe elbows must be sweep elbows, NOT short-radius elbows.

THE OUTDOOR SENSOR SUPPLIED WITH THE BOILER MUST BE INSTALLED UNLESS EXEMPTED BELOW:

IMPORTANT

In accordance with Section 303 of the 2007 Energy Act, this boiler is equipped with a feature that saves energy by reducing the boiler water temperature as the heating load decreases. This feature is equipped with an override which is provided primarily to permit the use of an external energy management system that serves the same function.

THIS OVERRIDE MUST NOT BE USED UNLESS AT LEAST ONE OF THE FOLLOWING CONDITIONS IS TRUE:

- An external energy management system is installed that reduces the boiler water temperature as the heating load decreases.
- This boiler is not used for any space heating.
- This boiler is part of a modular or multiple boiler system having a total input of 300,000 BTU/hr or greater.
- This boiler is equipped with a tankless coil (not applicable to Evergreen®).



Ratings — Multiple Evergreen® boilers

Figure 125 Ratings and engineering data — multiple Evergreen® boilers

Boilers in system Model EVG			Total Input	Output / Heating capacity	Boiler H.P.	Net water ratings	Manifolded combustion air duct size
			Input, MBH	Output, MBH	-	MBH	Square inches
70	110	155	-	Note 1	-	Note 2	
2			140	130	3.9	114	70
	2		220	202	6.0	176	110
		2	310	286	8.5	248	155
3			210	195	5.8	171	105
	3		330	303	9.1	264	165
		3	465	429	12.8	372	233
4			280	260	7.8	228	140
	4		440	404	12.1	352	220
		4	620	572	17.1	496	310
5			350	325	9.7	285	175
	5		550	505	15.1	440	275
		5	775	715	21.4	620	388
6			420	390	11.7	342	210
	6		660	606	18.1	528	330
		6	930	858	25.6	744	465
7			490	455	13.6	399	245
	7		770	707	21.1	616	385
		7	1085	1001	29.9	868	543
8			560	520	15.5	456	280
	8		880	808	24.1	704	440
		8	1240	1144	34.2	992	620

Notes	
1	Based on standard test procedures outlined by DOE for individual boilers.
2	Net AHRI ratings are based on piping and pickup allowance of 1.15. Consult Weil-McLain Technical Services for other allowances.
3	Total amp requirement includes up to four circulators, not exceeding 2.2 amps per circulator.
4	Operating weight is the total weight of the boiler, including water.
5	EVG 70 vent/air pipes can be either 2" or 3" pipe. EVG 110 and 155 vent/air pipes must be 3". All of the boilers will automatically de-rate as vent/air pipe length increases, due to the pressure loss through the piping. See Figure 124, page 139 for details. All EVG installations require a separate vent pipe and termination for each boiler. Vent piping cannot be manifolded. Install and terminate vents as described in vent/air installation instructions in this manual. Combustion air piping can be individually piped or manifolded. See the Advanced Manual for manifolded air piping.

Boiler Model	Shipping weight	Operating weight	Water content	Water flow rate per boiler		Vent/air pipe size: (Provide a separate vent for each boiler)	Electrical service required
				GPM @ 20°F rise	GPM @ 40°F rise		
EVG	Pounds per boiler	Pounds per boiler	Gallons per boiler				
		Note 4				Note 5	Note 3
70	125	112	2.54	6.5	3.3	2" or 3"	15.0
110	120	107	2.54	10.0	5.0	3"	15.0
155	142	129	3.22	14.3	7.2	3"	15.0



Installation and Service Certificate

Boiler Data		
Boiler Model / Series Evergreen ® _____ / Series _____		Date installed _____
CP Number _____	FUEL: Natural _____ LP _____	Btu Input _____
<p>CERTIFIED THAT:</p> <ul style="list-style-type: none"> <input type="checkbox"/> Installation instructions have been followed. <input type="checkbox"/> Check-out sequence has been performed. <input type="checkbox"/> Information on next two pages is certified to be correct. <input type="checkbox"/> Information received and left with owner/maintenance person. 		
<p>Installer _____</p> <p>_____</p> <p style="text-align: center;">(Company) (Address)</p>		
<p>_____</p> <p style="text-align: right;">(Phone) (Installer's Signature)</p>		



Installation and Gas Boiler Data Collection Sheet

Boiler Model / Series EVG _____ / Series _____		Date Installed: _____	
CP Number: _____	Fuel Type: Natural ___ LP ___	BTU Input: _____	
Flame signal on control display at HIGH fire: _____		Flame signal on control display at LOW fire: _____	
Was venturi changed? YES ___ NO ___	Was gas valve throttle adjusted? YES ___ NO ___	Was gas valve offset adjusted? YES ___ NO ___	
Boiler Settings			
Boiler Model: EVG _____		Boiler Address: _____	
Control Type: _____	Net Max On Time: _____ Min	System Type: _____	Priority 1 Settings
Altitude: _____ Feet	Net Min On Time: _____ Min	Target Mod Sensor: _____	
LP Gas: YES ___ NO ___	Max Rate On Net: _____ %	Target Adjust: _____	
ODT Sensor Exempt: YES ___ NO ___	Min Rate On Net: _____ %	Supply Max: _____ °F	
Manual Reset High Limit Temp: _____ °F	Rotation & Sequence	Supply Min: _____ °F	
WWSD Temp: _____ °F	Sequence Type: _____	OD Reset Max: _____ °F	
Adjust Outdoor: _____ °F	Base Rate High: _____ %	OD Reset Min: _____ °F	
Circulator Exercising	Base Rate Low: _____ %	Volts For Max: _____ V	
Circulator 1: ON ___ OFF ___	Boiler Rotation Type: _____	Volts For Min: _____ V	
Circulator 2: ON ___ OFF ___	Rotate Frequency: _____ Days	Boost Time: _____ Mins	
Circulator 3: ON ___ OFF ___	Force Lead Rotation: YES or NO	System Off Diff: _____ °F	
Boiler Circ: ON ___ OFF ___	Modbus Settings	System On Diff: _____ °F	
Freeze Protection	Enable: YES ___ NO ___	Add BLR Diff: _____ °F	
Circulator 1: ON ___ OFF ___	Address: _____	Drop BLR Diff: _____ °F	
Circulator 2: ON ___ OFF ___	Parity Bit: _____	Mod Delay Time: _____ Mins	
Circulator 3: ON ___ OFF ___	Baud Rate: _____ bps	Stabilization Time: _____ Mins	
Boiler Circ: ON ___ OFF ___	Stop Bit: YES ___ NO ___	Add Delay Time: _____ Sec	
Assign Inputs		Drop Delay Time: _____ Sec	
Input 1: Priority ___ Aux ___ OFF ___		Max BLR Temp: _____ °F	
Source: TT1 ___ OR 0-10V ___		Boiler On Diff: _____ °F	
Input 2: Priority ___ Aux ___ OFF ___		Boiler Off Diff: _____ °F	
Input 3: Priority ___ Aux ___ OFF ___		Max On Time: _____ Mins	
		Run Boiler Pump: YES ___ NO ___	
		Run Aux Pump/Output: YES ___ NO ___	
		Pre Pump: _____ Sec	
		Post Pump: _____ Sec	
		Max Rate: _____ %	
		Min Rate: _____ %	
		Max System BTUs: _____ MBUTs	
		Min Boilers On: _____	
		Additional Heat Demand: 1st ___ 2nd ___ OFF ___	
		Response Time: _____ Mins	



Installation and Gas Boiler Data Collection Sheet

CO2 @: High Fire _____ % Low Fire _____ %					
CO@: High Fire _____ ppm Low Fire _____ ppm					
Natural Gas / LP input rate measured: HIGH _____ CFH / LOW _____ CFH					
Priority 2 Settings		Priority 3 Settings		Priority 4 Settings (Multi Blr Sys Only)	
System Type:	_____	System Type:	_____	System Type:	_____
Target Mod Sensor:	_____	Target Mod Sensor:	_____	Target Mod Sensor:	_____
Target Adjust:	_____	Target Adjust:	_____	Target Adjust:	_____
Supply Max:	_____ °F	Supply Max:	_____ °F	Supply Max:	_____ °F
Supply Min:	_____ °F	Supply Min:	_____ °F	Supply Min:	_____ °F
OD Reset Max:	_____ °F	OD Reset Max:	_____ °F	OD Reset Max:	_____ °F
OD Reset Min:	_____ °F	OD Reset Min:	_____ °F	OD Reset Min:	_____ °F
Volts For Max:	_____ V	Volts For Max:	_____ V	Volts For Max:	_____ V
Volts For Min:	_____ V	Volts For Min:	_____ V	Volts For Min:	_____ V
Boost Time:	_____ Mins	Boost Time:	_____ Mins	Boost Time:	_____ Mins
System Off Diff:	_____ °F	System Off Diff:	_____ °F	System Off Diff:	_____ °F
System On Diff:	_____ °F	System On Diff:	_____ °F	System On Diff:	_____ °F
Add BLR Diff:	_____ °F	Add BLR Diff:	_____ °F	Add BLR Diff:	_____ °F
Drop BLR Diff:	_____ °F	Drop BLR Diff:	_____ °F	Drop BLR Diff:	_____ °F
Mod Delay Time:	_____ Mins	Mod Delay Time:	_____ Mins	Mod Delay Time:	_____ Mins
Stabilization Time:	_____ Mins	Stabilization Time:	_____ Mins	Stabilization Time:	_____ Mins
Add Delay Time:	_____ Sec	Add Delay Time:	_____ Sec	Add Delay Time:	_____ Sec
Drop Delay Time:	_____ Sec	Drop Delay Time:	_____ Sec	Drop Delay Time:	_____ Sec
Max BLR Temp:	_____ °F	Max BLR Temp:	_____ °F	Max BLR Temp:	_____ °F
Boiler On Diff:	_____ °F	Boiler On Diff:	_____ °F	Boiler On Diff:	_____ °F
Boiler Off Diff:	_____ °F	Boiler Off Diff:	_____ °F	Boiler Off Diff:	_____ °F
Max On Time:	_____ Mins	Max On Time:	_____ Mins	Min On Time:	_____ Mins
Min On Time:	_____ Mins	Run Boiler Pump:	YES___ NO___	Run Boiler Pump:	YES___ NO___
Run Boiler Pump:	YES___ NO___	Run Aux Pump/Output:	YES___ NO___	Run Aux Pump/Output:	YES___ NO___
Run Aux Pump/Output:	YES___ NO___	Pre Pump:	_____ Sec	Pre Pump:	_____ Sec
Pre Pump:	_____ Sec	Post Pump:	_____ Sec	Post Pump:	_____ Sec
Post Pump:	_____ Sec	Max Rate:	_____ %	Max Rate:	_____ %
Max Rate:	_____ %	Min Rate:	_____ %	Min Rate:	_____ %
Min Rate:	_____ %	Max System BTUs:	_____ MBUTs	Max System BTUs:	_____ MBUTs
Max System BTUs:	_____ MBUTs	Min Boilers On:	_____	Min Boilers On:	_____
Min Boilers On:	_____	Additional Heat Demand:	1st___ 2nd___ OFF___	Additional Heat Demand:	1st___ 2nd___ OFF___
Additional Heat Demand:	1st___ 2nd___ OFF___	Response Time:	_____ Mins	Response Time:	_____ Mins
Response Time:	_____ Mins				



Evergreen® Gas Boiler Data Collection Sheet

Customer Info:		Maintenance Info:	
Contact:		Name:	
Contractor:		Phone:	
Job name:		Model:	
City, state:		CP#:	
Distributor:		Installed:	

System Components:	Boiler/System Piping Details (Please Sketch)
Near boiler pipe size:	
DHW tank (yes/no):	
DHW direct/system:	
DHW model:	
DHW pipe size:	
DHW circulator model:	
Is there air in system?:	
Diagnostic Errors:	
Control fault:	
Ignition retries:	
Manual reset CNT:	
Auto reset CNT:	
Software Versions:	
Display:	
Main micro:	
Second micro:	

Lockout History #1		Lockout History #2		Lockout History #3	
Fault Name:		Fault Name:		Fault Name:	
Fault Type:		Fault Type:		Fault Type:	
Fault Time:		Fault Time:		Fault Time:	
Fault Date:		Fault Date:		Fault Date:	
Status:		Status:		Status:	
Temperatures:		Temperatures:		Temperatures:	
Status:		Status:		Status:	
Boiler out 1:		Boiler out 1:		Boiler out 1:	
Boiler out 2:		Boiler out 2:		Boiler out 2:	
Boiler in:		Boiler in:		Boiler in:	
Flue 1:		Flue 1:		Flue 1:	
Flue 2:		Flue 2:		Flue 2:	
Outdoor:		Outdoor:		Outdoor:	
Inputs:		Inputs:		Inputs:	
Status:		Status:		Status:	
Input 1:		Input 1:		Input 1:	
Input 2:		Input 2:		Input 2:	
Input 3:		Input 3:		Input 3:	
Manual limit:		Manual limit:		Manual limit:	
Auto limit:		Auto limit:		Auto limit:	
Low WTR Cutoff:		Low WTR Cutoff:		Low WTR Cutoff:	
Blower Speed:		Blower Speed:		Blower Speed:	
Flame signal:		Flame signal:		Flame signal:	
Outputs:		Outputs:		Outputs:	
Status:		Status:		Status:	
Gas valve:		Gas valve:		Gas valve:	
Output 1:		Output 1:		Output 1:	
Output 2:		Output 2:		Output 2:	
Output 3:		Output 3:		Output 3:	
Blower signal:		Blower signal:		Blower signal:	