

# Installation Manual

Montageanleitung  
Instructions de montage  
Istruzioni per il montaggio

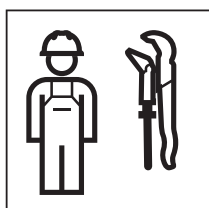



## Product Data

### Product Specifications

Geberit Model No. / Flush volume:

- 111.012.00.1 / 1.6/0.8 gpf (6.0/3.0 lpf)
- 111.018.00.1 / 1.28/0.8 gpf (4.8/3.0 lpf)

Concealed tank and bowl carrier, wall-hung two-hole toilet bowl and actuator plate.

Tank and carrier system shall fit within a minimum 5 1/2" (140) deep wall with studs placed 19 3/4" (500) apart, water supply shall be 1/2" copper, minimum water pressure 35 PSI. The bowl shall be an IAMPO listed wall-hung bowl to match flush volumes shown in table. The carrier shall have adjustable height for 15" (381) to 19" (483) bowl rim height. Actuator plates shall be die-cast zinc, plastic or stainless steel and plated to preserve the material's integrity.



### Features

- Square structural 16 gauge powder coated steel frame
- Actuator dimension: 8 3/8" (212) width 5 2/3" (142) height
- Carrier height adjustable range 15" (381) to 19" (483) bowl rim height
- Impact resistant high density polyethylene tank HDPE
- Insulated to prevent condensation
- Anti-siphon fill valve meets ANSI / ASSE 1002-99 standard

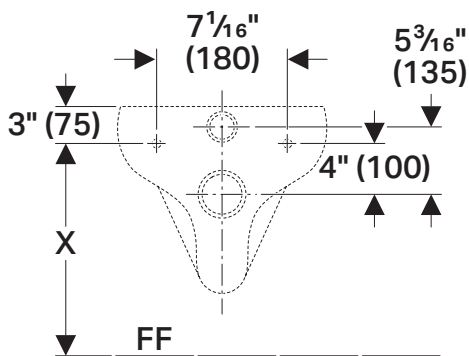

### Dimensions

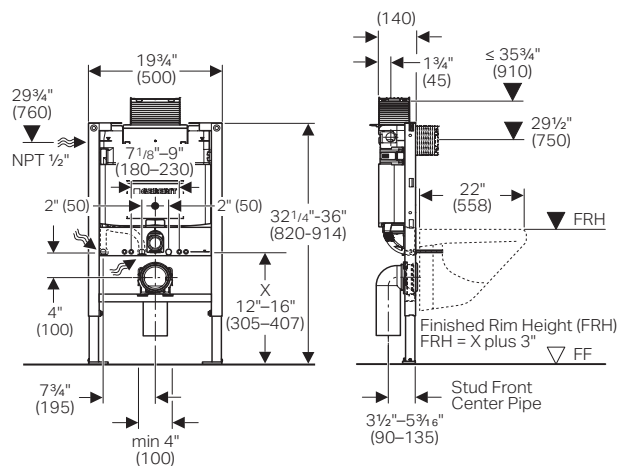

### Material Determination

Recommended material for wall surface construction:

- Gypsum / green board
- Cement board
- Tile backer board
- Ceramic tile surface



Wall thickness not to exceed 3"

### Options



Omega20, Dual flush actuator



Omega30, Dual flush actuator



Omega60, Dual flush actuator



Vertical discharge elbow 3" DWV standard

- Horizontal left: 366.914.16.1

- Horizontal right: 366.913.16.1

### Warranty

Limited lifetime warranty on tank and carrier.  
10 year warranty on fill valve and flush valve.  
One year warranty on actuator plate.



# Installation

## Installation Requirements

To install tank and carrier, a 2 x 6" wood frame or metal frame construction is required. Studs must be placed 19 3/4" apart (clearance) where carrier will be positioned inside the wall.

## Bowl Finished Rim Height (FRH)

Remove carrier and installation hardware from its box. Determine FRH for wall-hung bowl and adjust carrier height in accordance with requirement. Dimensions can be taken from bowl or carrier specification sheet. Be sure to allow for finished floor and sole plate height.

## Discharge elbow installation

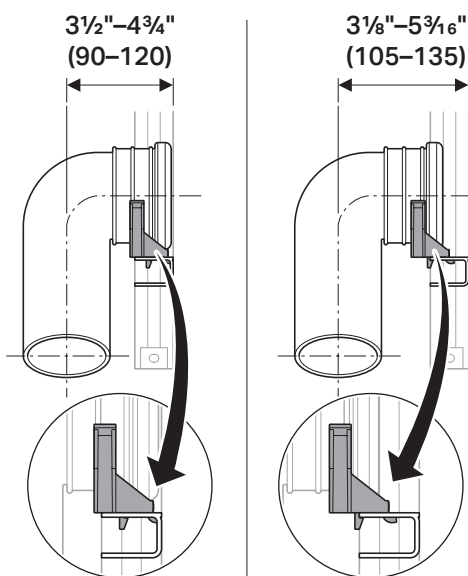

1

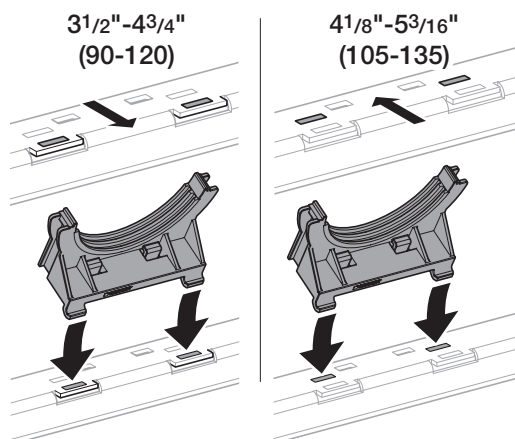

2

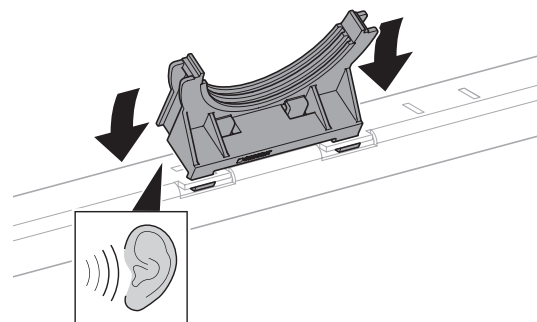

3

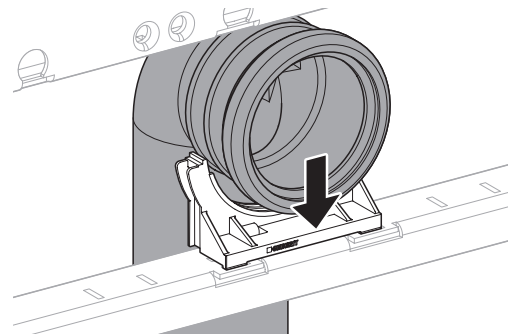
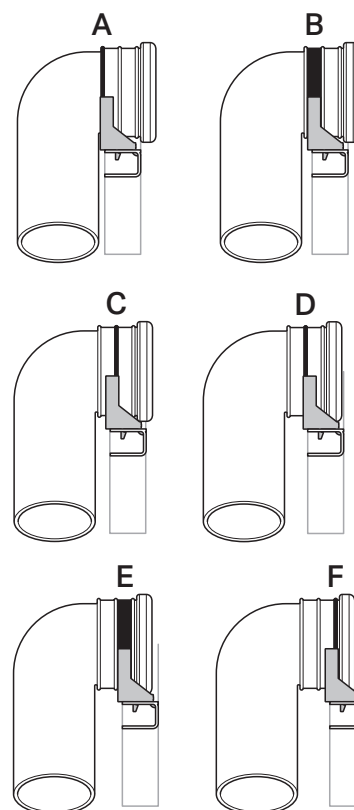

4

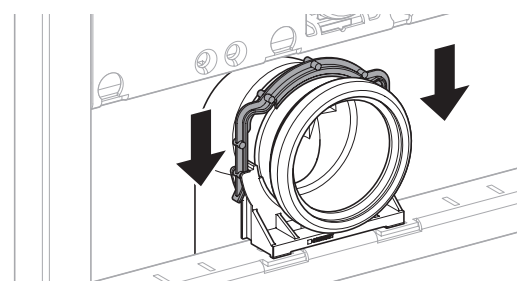

## Tank and carrier installation

- 1** Locate carrier supporting studs and reinforce with additional nails. Ensure rough-in for the carrier is plumb and square. Wall framework must be affixed to the floor and ceiling for maximum support.
- 2** Position carrier unit in the prepared opening. Carrier face plate must be flush with the front of the surrounding studs so that maximum support for the wall sheeting (applied later) will be accomplished. With carrier still in place, mark all anchor and bolt hole locations on sole plate and studs. Mark location for the 3" DWV discharge pipe.
- 3** Pull out carrier from framework and drill six (6) pilot holes (3/16") for the supplied lag screws where marked on sole plate. Also drill six (6) bolt holes (5/16") where marked on both studs. Use hole saw and bore a 4" hole through sole plate and floor for the discharge stop out pipe.
- 4** Install 3" DWV waste pipe through floor and connect to waste line (i.e. PVC, copper, cast iron).
- 5** Set carrier unit sideways back into framework and bolt in place with hardware provided.
- 6** Complete waste elbow connection with 3" DWV shielded coupling (D - provided) to waste pipe.

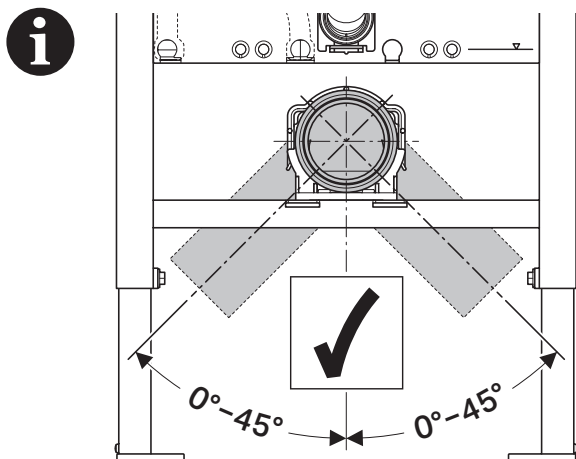

- 7** Install two (2) 1/2" x 6" fixture support rods with plastic sleeves (A), yellow pipe caps (B) and mud guard (C) for protection during wall surface construction.

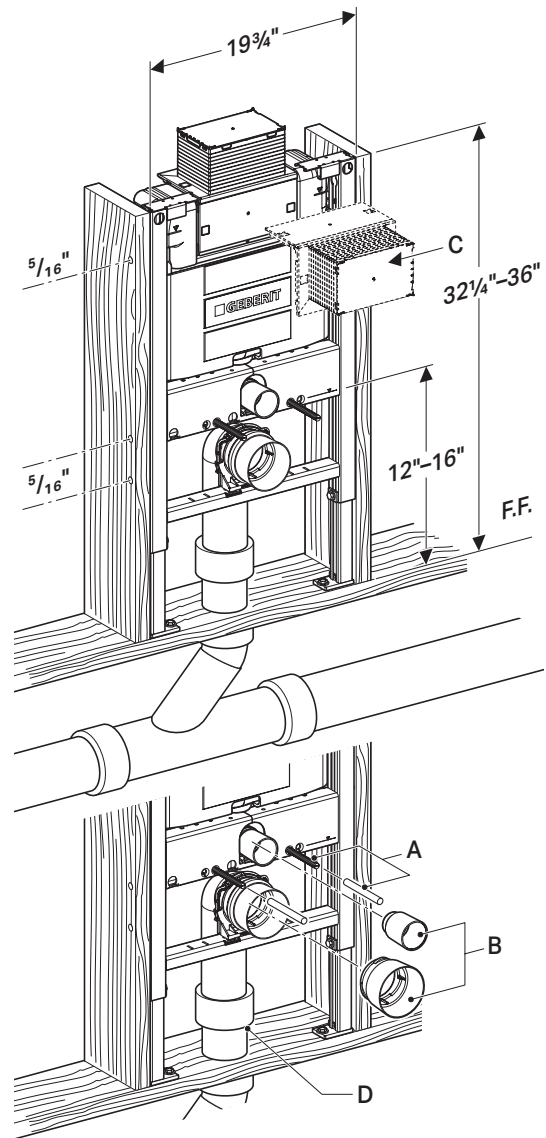

Install 1/2" rods with plastic sleeves (A), pipe plugs (B) and mud guard (C) during the rough-in installation. Complete waste elbow connection with 3" DWV shielded coupling (D - provided) to waste pipe.

- i** For finishing the installation of bowl and actuator plate see detailed instructions.

## Water supply installation

1

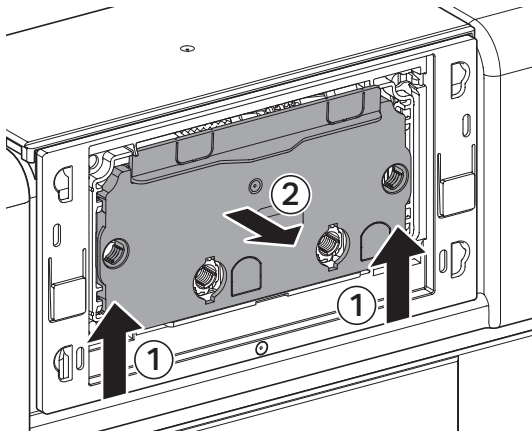

2

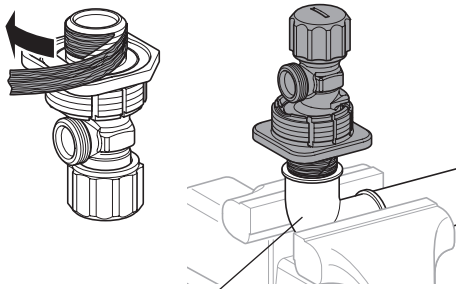

NPT 1/2" elbow

3

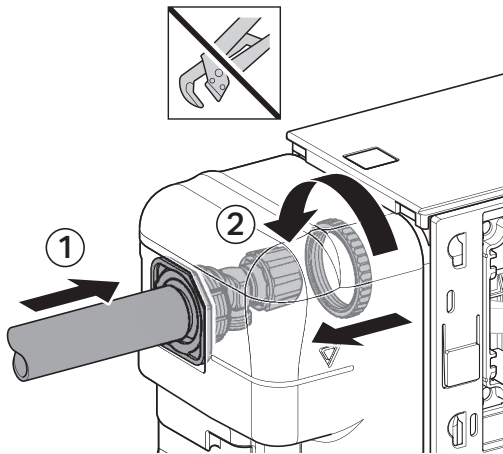

4

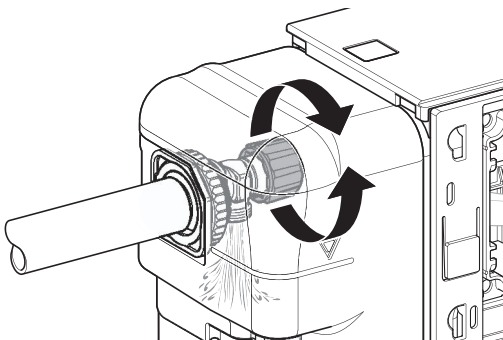

## Mud guard installation

▶

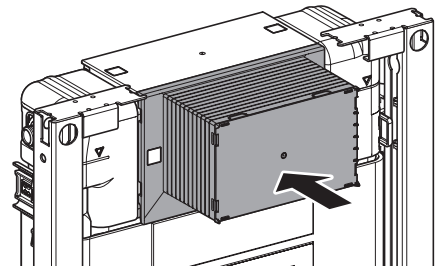
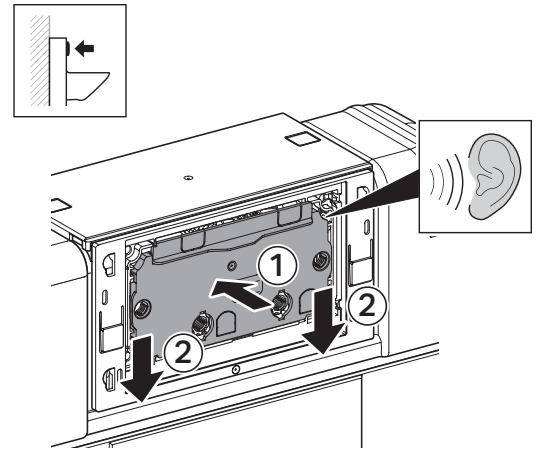

**i**

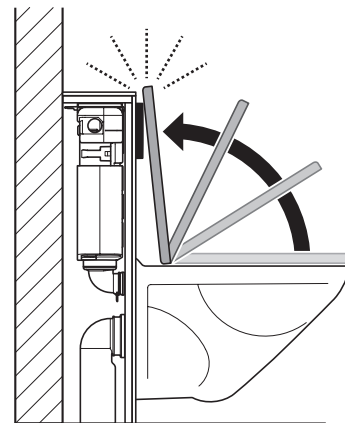

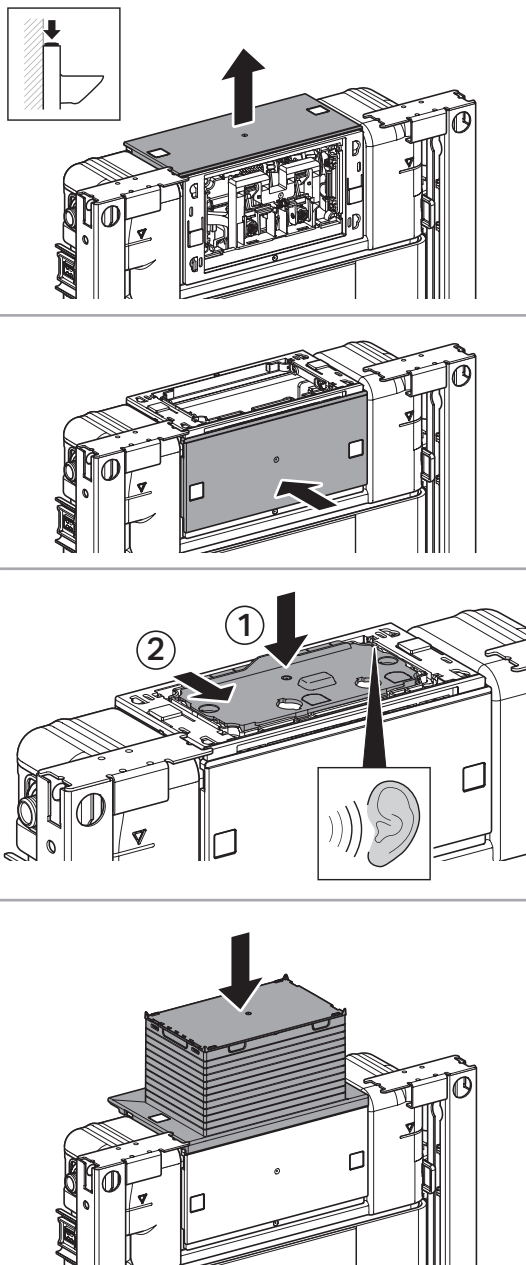

- 1** Install wall surface material such as high density Gypsum / green Board, Cement Board, Tile Backer Board with optional ceramic tile finish surface as the most suitable materials. Provide cut outs for the protruding parts like inlet and outlet pipes and the rectangular access box.

## Bowl installation

- 1** Remove yellow protection plugs and seals from pipes.

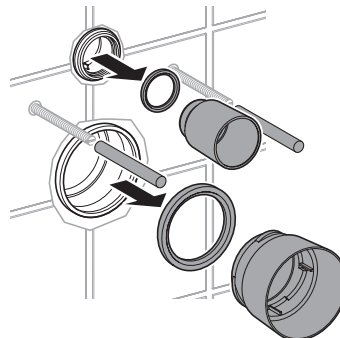

- 2** Insert discharge pipe into the pipe hub in the wall. Place a straight edge flush against the wall and mark a line on the pipe. Fit finned rubber seal onto flush pipe. Repeat same procedure for discharge pipe.

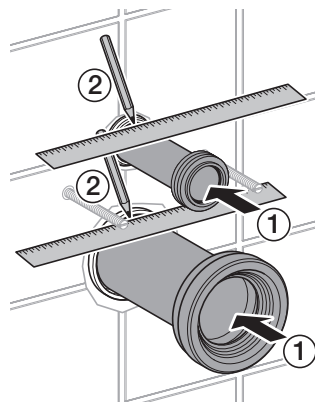

- 3** Place discharge pipe with gasket into waste outlet of bowl. Also place flush pipe with fin gasket into inlet of bowl. Then mark a second line on both pipes.

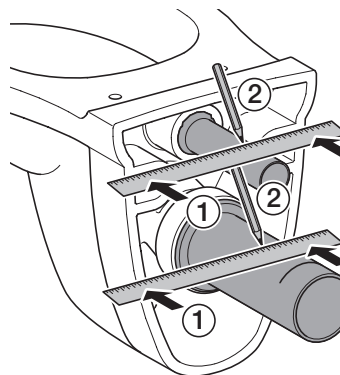

- 4** Add dimension X and 1/8". Using that dimension, mark a line on the pipe measuring from the hub side. Cut off the pipe at the line with a pipe cutter.

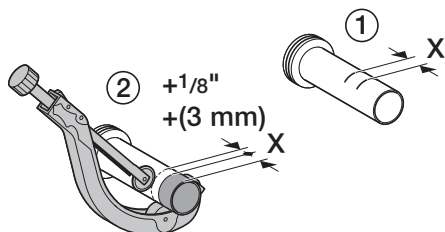

- 5** Add dimension Y and 1/8". Using that dimension, mark a line on the pipe measuring from the hub side. Cut off the pipe at the line with a pipe cutter.

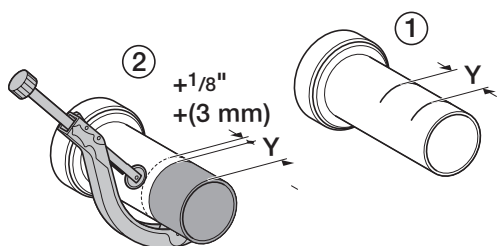

- 6** Bevel the sharp edges as shown to assure a smooth insertion into the pipe hubs in the wall.

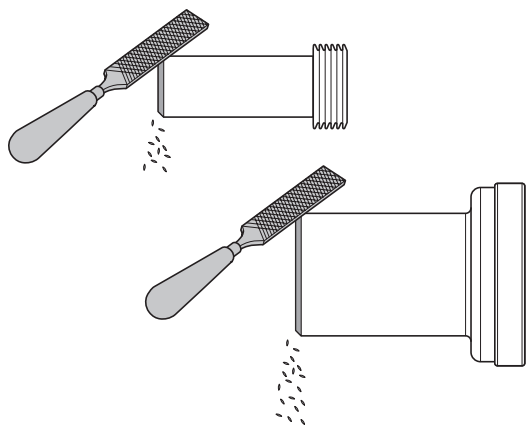

- 7** Install both seals into the pipes in the wall. Lubricate seals with appropriate rubber seal lubricant.

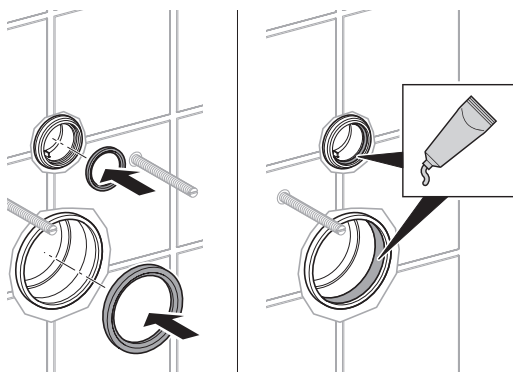

- 8** Remove protective sleeves from mounting rods. Determine protruding rod length for bowl installation. Install both pipes into the hubs in the wall.

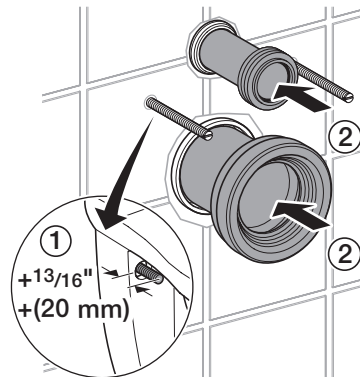

**CAUTION**  
**High torque forces**  
 WC ceramic appliance may break  
 ▶ Do not overtighten hex nuts

**i** Sound insulation pad is optional or required.

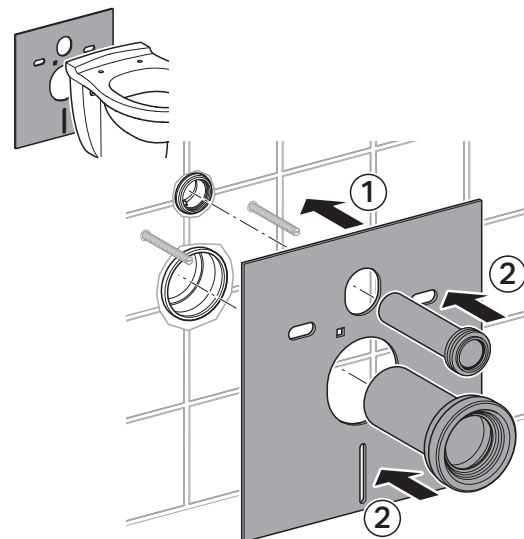

- 9** Place bowl onto rods. Attach cap washer with nose up and facing forwards onto rods. Install washer and hex nuts, hand tighten. Level bowl. Tighten hex nuts. Snap on the bolt caps. Cut off insulation pad if mounted.

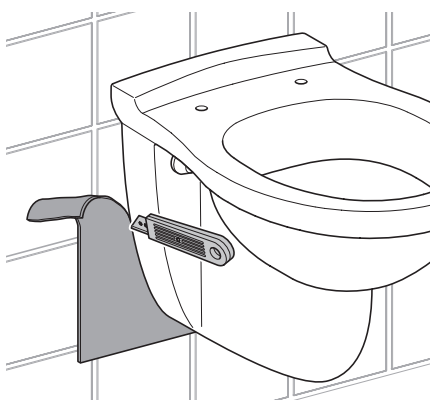
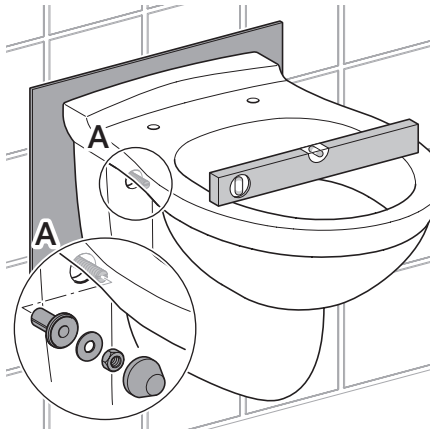

- 10** Seal gap around bowl with silicone.

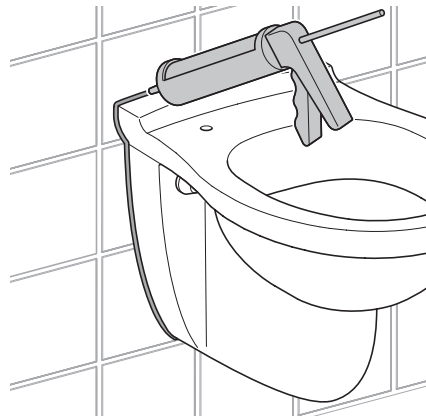

## Contact

**Geberit**  
2100 Clearwater Drive, Des Plaines, IL 60018-5999

Phone: (847) 803 5000 • Fax: 847/803-5454  
For Technical Assistance: 800 / TEC-TRUE (800-832-8783)

→ [www.geberit.us](http://www.geberit.us)

**Geberit International AG, Schachenstrasse 77, CH-8645 Jona**

T +41 55 221 63 00

F +41 55 221 63 16

[documentation@geberit.com](mailto:documentation@geberit.com)

→ [www.geberit.com](http://www.geberit.com)