

## Residential Atmospheric Vent Gas Water Heater



Photo is of  
RG240T6N

### The Atmospheric Vent FVIR Defender Safety System<sup>®</sup> Models Feature:

- **Bradford White ICON System<sup>®</sup>**—Intelligent gas control with proven millivolt powered technology and built-in piezo igniter. A standard, off-the-shelf thermopile converts heat energy from the pilot flame into electrical energy to operate the gas valve and microprocessor. No need for external electricity.
  - **Enhanced Performance**—Proprietary algorithms provide enhanced First Hour Rating and tighter temperature differential.
  - **Advanced Temperature Control System**—Microprocessor controls burner operation for consistent and accurate water temperature levels up to 160°F (71°C).
  - **Intelligent Diagnostics**—Exclusive multicolor LED light indicates operation status/service required.
- **Advanced ScreenLok<sup>®</sup> Technology Flame Arrestor Design**—Flame arrestor is designed to prevent ignition of flammable vapor outside of the water heater.
- **Resettable Thermal Switch**—Proven and reliable bimetallic switch prevents burner and pilot operation in case of ongoing flammable vapors burning inside of the combustion chamber or restricted air flow.
- **Maintenance-Free**—No regular cleaning of air inlet openings or flame arrestor is required under normal conditions.
- **Sight Window**—Offers a view into the combustion chamber to observe the operation of the pilot and burner.
- **Factory-Installed Hydrojet<sup>®</sup> Total Performance System**—Sediment reducing device that also increases first hour rating of hot water while minimizing temperature build-up in tank.
- **Vitraglas<sup>®</sup> Lining**—An exclusively engineered enamel formula that provides superior tank protection from the highly corrosive effects of hot water. This formula (Vitraglas<sup>®</sup>) is fused to the steel surface by firing at a temperature of over 1600°F (871°C).
- **Small Diameter Models Available**—for limited space installations.
- **Insulation System**—Non-CFC foam covers the sides and top of the tank, reducing heat loss. This results in less energy consumption, improved efficiencies, and jacket rigidity.
- **Pedestal Base.**
- **Water Connections**—3/4" (19mm) NPT factory installed true dielectric fittings.
- **Factory-Installed Heat Traps.**
- **Protective Magnesium Anode Rod.**
- **3x4 "Snap Lock" Draft Diverter**—Allows either 3" (76mm) or 4" (102mm) vent connections with inputs of 40,000 BTU/Hr. or less. Over 40,000 BTU/Hr. has the 4" (102mm) "Snap Lock" Draft Diverter.
- **T&P Relief Valve**—Installed.
- **Low Restrictive Brass Drain Valve**—Durable tamper proof design.
- **NOx Emissions**—Less than 40 ng/J.

### FEATURING:



\*May vary by region



### 6 or 10-Year Limited Tank Warranties / 6 or 10-Year Limited Warranty on Component Parts.

For more information on warranty, please visit [www.bradfordwhite.com](http://www.bradfordwhite.com)

For products installed in USA, Canada, and Puerto Rico. Some states do not allow limitations on warranties. See complete copy of the warranty included with the heater.

# Residential Atmospheric Vent Gas Water Heater

## Atmospheric Vent Models

NATURAL GAS AND LIQUID PROPANE GAS

Meet or exceed ASHRAE 90.1b (current standard) C.E.C. Listed  
Recovery efficiency ranging up to 80%

Model Number	Nominal Gal. Capacity		DOE Rated Storage Volume (Gal.)	BTU/Hr. Input	LP BTU/Hr. Input	First Hour Rating (Gal.)	Uniform Energy Factor	Recovery at 90°F Rise*				Model Number	Nominal Liter Capacity	DOE Rated Storage Volume (Liters)	kW Input	LP kW Input	First Hour Rating (Liters)	Uniform Energy Factor	Recovery at 50°C Rise*	
	U.S. Gal.	Imp. Gal.						U.S. GPH	Imp. GPH	LP U.S. GPH	LP Imp. GPH								Liters/Hour	LP Liters/Hour
RG130T6N	30	25	29	27,000	27,000	46	0.54	29	24	29	24	RG130T6N	114	110	7.9	7.9	174	0.54	110	110
RG230T6N	30	25	29	32,000	31,000	60	0.60	34	28	33	23	RG230T6N	114	110	9.4	9.1	227	0.60	129	125
RG230S6N	30	25	29	30,000	26,000	49	0.54	32	37	32	27	RG230S6N	114	110	8.8	7.6	186	0.54	121	121
RG140T6N	40	33	38	34,000	34,000	64	0.59	37	31	37	31	RG140T6N	151	144	10.0	9.9	243	0.59	139	139
RG240T6N	40	33	38	40,000	36,000	75	0.64	43	36	34	33	RG240T6N	151	144	11.7	10.6	284	0.64	163	129
RG240S6N	40	33	38	40,000	38,000	69	0.58	43	36	41	34	RG240S6N	151	144	11.7	11.1	262	0.58	163	155
RG150T6N	50	42	47	34,000	34,000	75	0.63	37	31	37	31	RG150T6N	189	178	10.0	9.9	284	0.63	139	139
RG250T6N	50	42	48	40,000	36,000	81	0.63	43	36	41	34	RG250T6N	189	182	11.7	10.6	307	0.63	163	155
RG250L6N	48	40	47	40,000	38,000	77	0.63	43	36	41	34	RG250L6N	182	178	11.7	11.1	292	0.63	163	155
RG250S6N	50	42	47	50,000	48,000	75	0.63	54	45	52	45	RG250S6N	189	178	14.7	14.1	284	0.63	204	197

Model Number	A Floor to Exhaust Conn. in.	B Jacket Dia. in.	C Vent Size in.	D Floor to T&P Conn. in.	E Floor to Gas Conn. in.	F Floor to Top of Heater in.	G Floor to Water Conn. in.	H Depth in.	J C/L of Water Conn. in.	M Water Conn. NPT in.	S Gas Conn. Size in.	Approx. Shipping Weight lbs.
RG130T6N	59 3/4	16	3 or 4	49 3/4	13	56 1/4	57	19 1/2	8	3/4	1/2	106
RG230T6N	59 3/4	18	3 or 4	49 3/4	13	56 1/4	57	21 1/2	8	3/4	1/2	116
RG230S6N	49 1/4	20	3 or 4	38 7/8	13	45 3/4	46 1/2	23 1/2	8	3/4	1/2	113
RG140T6N	61 5/16	18	3 or 4	51 5/8	13	57 13/16	59 9/16	21 1/2	8	3/4	1/2	132
RG240T6N	60 1/8	20	3 or 4	49 3/4	13	56 3/8	57 3/8	23 1/2	8	3/4	1/2	134
RG240S6N	51 9/16	22	3 or 4	41 1/16	13	48 1/16	48 13/16	25 1/2	8	3/4	1/2	139
RG150T6N	60 1/8	20	3 or 4	49 15/16	13	56 3/8	57 3/8	23 1/2	8	3/4	1/2	148
RG250T6N	60 1/8	22	3 or 4	49 15/16	13	56 3/8	57 3/8	25 1/2	8	3/4	1/2	154
RG250L6N	51 9/16	24	3 or 4	40 11/16	13	48 1/16	48 13/16	27 1/2	8	3/4	1/2	170
RG250S6N	60 1/8	22	4	49 15/16	13	56 3/8	57 3/8	25 1/2	8	3/4	1/2	167

Model Number	A Floor to Exhaust Conn. mm.	B Jacket Dia. mm.	C Vent Size mm.	D Floor to T&P Conn. mm.	E Floor to Gas Conn. mm.	F Floor to Top of Heater mm.	G Floor to Water Conn. mm.	H Depth mm.	J C/L of Water Conn. mm.	M Water Conn. NPT mm.	S Gas Conn. Size mm.	Approx. Shipping Weight kg.
RG130T6N	1518	406	76 or 102	1264	330	1429	1448	495	203	19	13	48
RG230T6N	1518	457	76 or 102	1264	330	1429	1448	546	203	19	13	53
RG230S6N	1251	508	76 or 102	987	330	1162	1181	597	203	19	13	51
RG140T6N	1557	457	76 or 102	1311	330	1468	1513	546	203	19	13	60
RG240T6N	1527	508	76 or 102	1264	330	1438	1457	597	203	19	13	61
RG240S6N	1310	559	76 or 102	1043	330	1221	1240	648	203	19	13	63
RG150T6N	1527	508	76 or 102	1268	330	1438	1457	597	203	19	13	67
RG250T6N	1527	559	76 or 102	1268	330	1438	1457	648	203	19	13	70
RG250L6N	1310	610	76 or 102	1033	330	1221	1240	699	203	19	13	77
RG250S6N	1527	559	102	1268	330	1438	1457	648	203	19	13	76

Propane models feature a Titanium Stainless Steel propane burner. For Propane (LP) models change suffix "N" to "X".  
For 10 year models, change suffix from "6" to "10".

\* Based on manufacturer's rated recovery efficiency.

• Models feature optional top T&P location and must be specified when ordering.

Note: RG230S6N and RG250L6N do not have top T&P option.

Uniform Energy Factor and First Hour Rating is based on the latest AHRI directory listings.

### General:

#### Meets NAECA Requirements.

All gas water heaters are certified at 300 PSI test pressure (2068 kPa) and 150 PSI working pressure (1034 kPa). All water connections are 3/4" NPT (19mm) on 8" (203mm) centers. All gas connections are 1/2" (13mm).

All models design-certified by CSA International (formerly AGA/CGA), ANSI standard Z21.10.1 and peak performance rated.

**Dimensions and specifications subject to change without notice in accordance with our policy of continuous product improvement.**

#### Suitable for Water (Potable) Heating and Space Heating.

Toxic chemicals, such as those used for boiler treatment, shall NEVER be introduced into this system. This unit may NEVER be connected to any existing heating system or component(s) previously used with a non-potable water heating appliance.

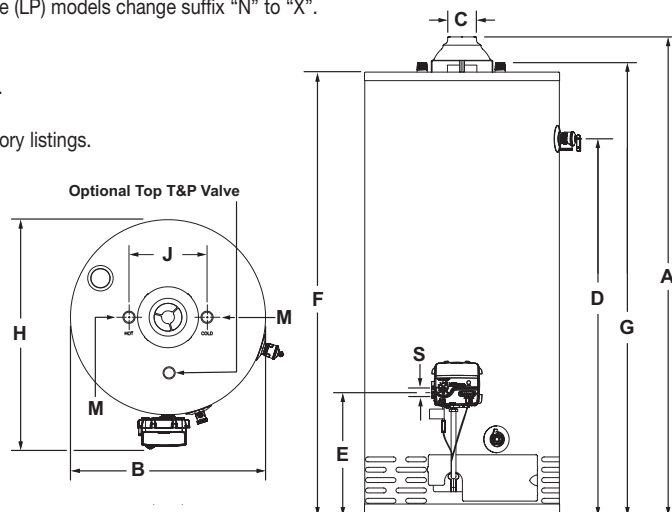

— BRADFORD WHITE IS —



Sales: 800-523-2931 ■ Fax 215-641-1612

24/7 Technical Support: 800-334-3393 ■ Email techserv@bradfordwhite.com

Built to be the Best