

PRODUCT INTRODUCTION

PRESSURE MEASUREMENT INSTRUMENTATION



351 BELL KING ROAD
NEWPORT NEWS, VA 23606

WWW.KELLERAMERICA.COM
SALES@KELLERAMERICA.COM
TOLL-FREE: 877-253-5537

SUBMERSIBLE LEVEL TRANSMITTERS

KELLER AMERICA OFFERS SEVERAL SUBMERSIBLE LEVEL TRANSMITTERS, EACH DESIGNED TO PROVIDE THE BEST PRICE, PERFORMANCE, AND VALUE FOR YOUR APPLICATION. EACH OF THESE TRANSMITTERS IS BUILT TO ORDER IN THE UNITED STATES WITH A SHORT, 3-DAY LEAD TIME AND SEVERAL MODELS INCLUDE GUARANTEED LIGHTNING PROTECTION AT NO ADDITIONAL COST.

THE FOLLOWING PAGES WILL PROVIDE PRODUCT-SPECIFIC INFORMATION. HOWEVER, FOR THE MOST CURRENT INFORMATION, PLEASE VISIT WWW.KELLERAMERICA.COM OR CONTACT A KELLER SALES ASSOCIATE.



Levelgage

General Purpose Submersible Level Transmitter



Features:

- 4...20mA models include guaranteed lightning protection at no additional cost.
- 16-bit internal digital error correction for cost-effective low Total Error Band (TEB)
- 316L SS construction
- 2-year warranty covers defects in materials and workmanship.
- Standard outputs simplify interface to controls, data collection, and telemetry systems.
- Built in the U.S.A. ARRA Section 1605 Compliant.
- Standard 3 day lead time at no additional charge.

Description:

The Levelgage by Keller America is designed for indefinite submersion in a wide variety of liquid media. Intended for general purpose monitoring and control applications, the Levelgage is a smart choice for OEMs, system integrators and end-users alike.

The Levelgage combines proven piezoresistive silicon sensor technology with Keller's state-of-the-art signal conditioning circuitry to provide an accurate, reliable, and temperature compensated analog output.

Plus, Keller America's guaranteed lightning protection makes this transmitter ideal for installation in areas prone to chronic damage due to transients caused by lightning.

For more information on the Levelgage, or any other Keller product, please contact Keller America, or view the entire Keller catalog at:

<http://www.kellerafrica.com/datasheets.html>.

Specifications:

Available ranges _{1,2}		Wetted Materials	Standard 316L S.S.
Relative	Infinite from 0..3 to 0..900ft W.C.		Polyamide
Absolute	Infinite from 0..2Bar to 0..11 Bar		Fluorocarbon
Accuracy, TEB ₃	Standard 1% BR TEB	Environmental Protection	IP68
	Optional 0.5% BR TEB	Cable	Standard Polyethylene
Compensated Temp. Range	-10...60°C		Optional Hytrel
Output	4...20mA, 0...5VDC, 0...10VDC		Optional Tefzel
Resolution	0.002% FS	Optional Accessories	Drying Tube
Supply			Aneroid Bellows
4...20 mA Output	11...28 VDC _{4,5}		1/2"NPT Conduit Fitting
0...5 VDC Output	8...28 VDC ₅		Stabilizing Weight
0...10 VDC Output	13...28 VDC ₅		Termination Enclosure
Load Resistance			Cable Hanger
Current	<(Supply-11V)/0.022A		Digital Display / Process Controller
Voltage	>4k ohm		Open-face nose cap

Specifications and dimensions are subject to change without notice.

Dimensions:

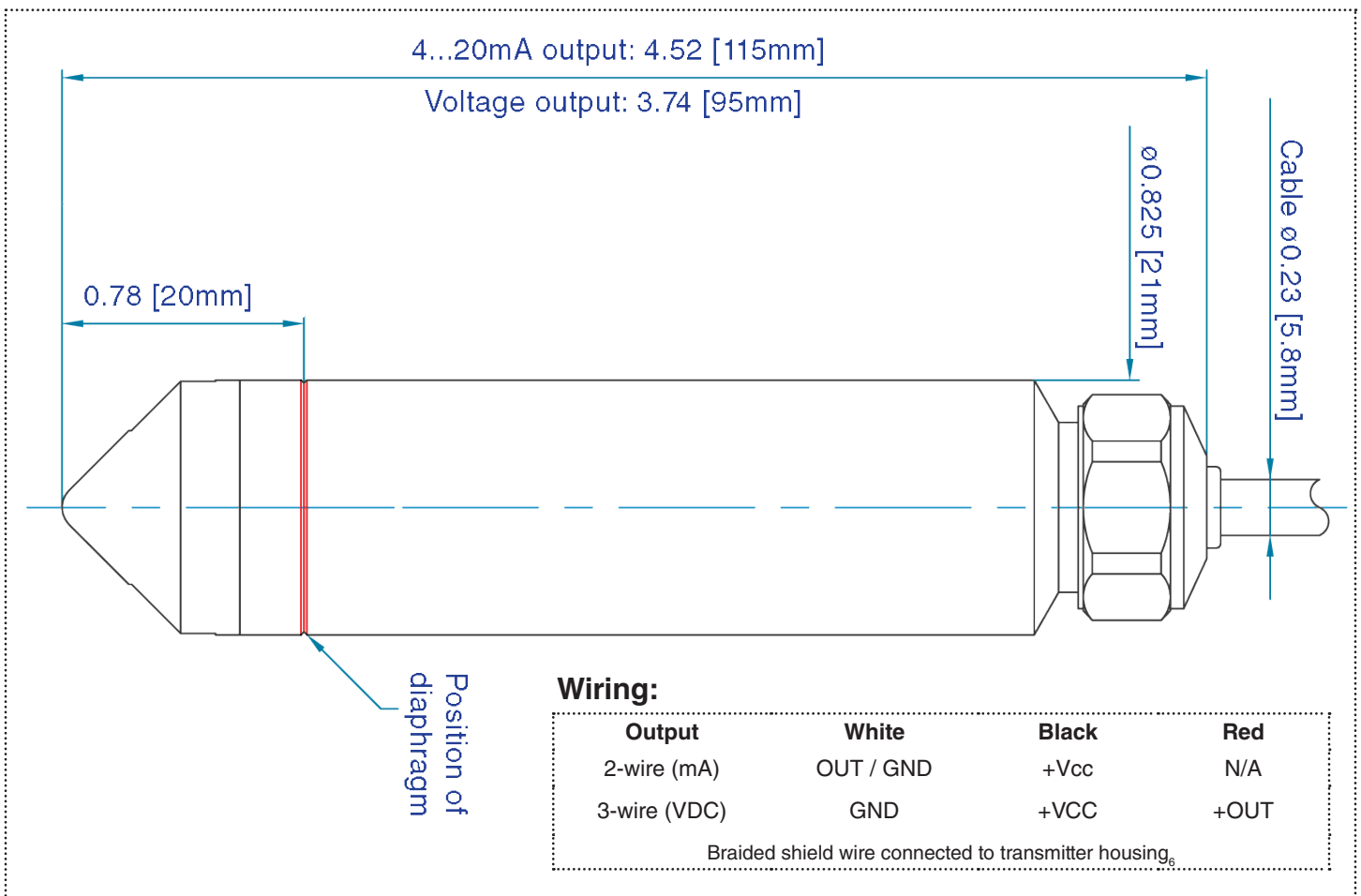

Notes:

- The Levelage can be provided with custom calibration at no extra cost for fluids other than water, provided the specific gravity is given at the time the order is placed.
- Level range may be specified in units of lb/in²(psi), inches WC or feet WC. Keller America uses the International Standard conversion of 2.3067 feet WC/psi.
- Static accuracy includes the combined effects of non-linearity, hysteresis, and non-repeatability at room temperature (25°C). Total Error Band (TEB) includes the combined effects of non-linearity, hysteresis, and non-repeatability as well as thermal dependencies, over the compensated temperature range, expressed as a percentage of the basic range (BR). The calculation for maximum TEB on intermediate ranges (IR) is: $TEB_{IR} = (BR/IR) \times TEB_{BR}$
- Internal lightning protection increases the minimum-required supply voltage, due to internal resistance of the surge protectors. In addition, cable resistance (~70Ω /1000ft) adds to the supply requirement. In order to insure proper system operation, calculate the minimum required supply voltage (at the source) as follows:
 For two-part (internal+external) system (recommended):
MINIMUM SUPPLY VOLTAGE = 11.6 + 0.022 (CABLE LENGTH x 0.07) VDC
 For internal only protector (standard with 4-20mA output):
MINIMUM SUPPLY VOLTAGE = 11 + 0.022 (CABLE LENGTH x 0.07) VDC
- Nominal values may be higher depending upon cable length. Cable resistance = ~70Ω / 1000ft.
- The drain / shield is connected to the transmitter housing. For lightning protection to function properly (4-20mA only) the shield wire must be connected to a good earth ground!

LevelRat

Non-Fouling Submersible Level Transmitter



Features:

- 4...20mA models include guaranteed lightning protection at no additional cost.
- 16-bit internal digital error correction for cost-effective low Total Error Band (TEB)
- 316L SS housing construction.
- Non-fouling diaphragm for superior resistance to puncture.
- 2-year warranty covers defects in materials and workmanship.
- Standard outputs simplify interface to controls, data collection, and telemetry systems.
- Built in the U.S.A. ARRA Section 1605 Compliant.
- Standard 3-day lead time at no additional charge.

Description:

Specifically designed for extended service in sewage lift station environments, the LevelRat™ by Keller America features a wide sensing diaphragm yet small overall size. Unlike similar, competing models which feature a fragile Teflon®-coated rubber diaphragm, the LevelRat incorporates a monolithic diaphragm which combines the non-stick quality of Teflon with superior toughness and abrasion resistance.

Perfectly suited for pump control applications, the LevelRat is compatible with any standard 2-wire, 4-20 mA current loop. Keller America's guaranteed lightning protection makes this transmitter ideal for installation in areas prone to chronic damage due to transients caused by lightning.

For more information on the LevelRat, or any other Keller product, please contact

Keller America, or view the entire Keller catalog at:

<http://www.kelleramerica.com/datasheets.html>

Specifications:

Available ranges _{1,2}		Wetted Materials	Standard 316L S.S.
Relative	Infinite from 0..5 to 0...100ft W.C.		Polyamide
Accuracy, TEB ₃	Standard 0.5% BR TEB		Fluorocarbon
Compensated Temp. Range	-10...60°C		PEEK
Output - Analog	4...20mA, 0..5VDC, or 0..10VDC	Cable	Standard Polyethylene
Output - Digital	RS485		Optional Hytrel
Resolution	0.002% FS		Optional Tefzel
Supply		Optional Accessories	Drying Tube
4...20 mA Output	11...28 VDC ₄		Aneroid Bellows
0..5 VDC Output	8...28 VDC ₅		1/2"NPT Conduit Fitting
0...10 VDC Output	13...28 VDC ₅		Stabilizing Weight
Load Resistance			Termination Enclosure
Current	<(Supply-11V)/0.022A		Cable Hanger
Voltage	>4k ohm		Digital Display / Process Controller
Environmental Protection	IP68		External Surge Protector

Specifications and dimensions are subject to change without notice.

Dimensions:

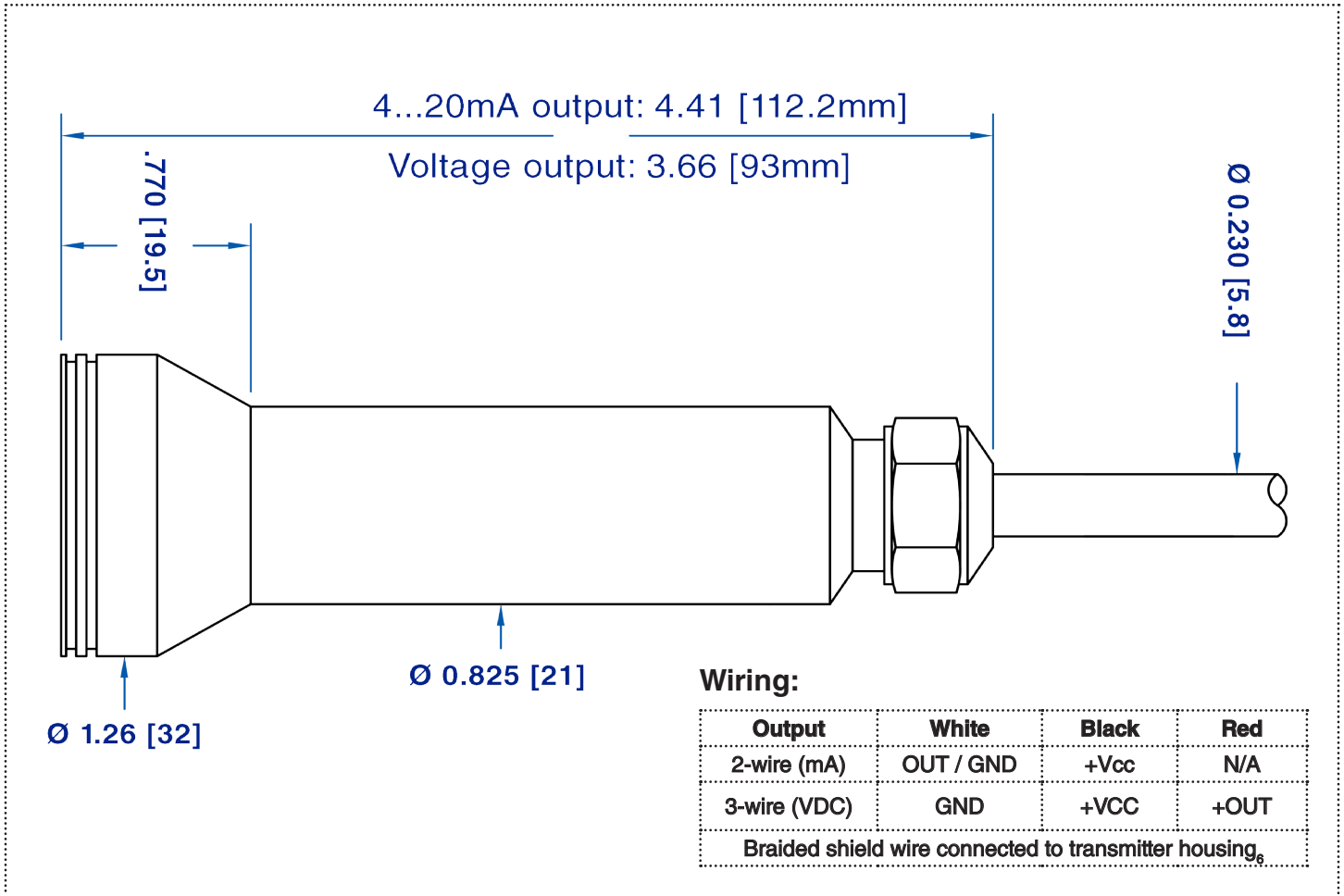

Notes:

1. The LevelRat can be provided with custom calibration at no extra cost for fluids other than water, provided the specific gravity is given at the time the order is placed.
2. Level range may be specified in units of lb/in²(psi), inches WC or feet WC. Keller America uses the International Standard conversion of 2.3067 feet WC/psi.
3. Static accuracy includes the combined effects of non-linearity, hysteresis, and non-repeatability at room temperature (25°C). Total Error Band (TEB) includes the combined effects of non-linearity, hysteresis, and non-repeatability as well as thermal dependencies, over the compensated temperature range, expressed as a percentage of the basic range (BR). The calculation for maximum TEB on intermediate ranges (IR) is: $TEB_{IR} = (BR/IR) \times TEB_{BR}$
4. Internal lightning protection increases the minimum-required supply voltage, due to internal resistance of the surge protectors. In addition, cable resistance (~70Ω /1000ft) adds to the supply requirement. In order to insure proper system operation, calculate the minimum required supply voltage (at the source) as follows:
 For two-part (internal+external) system (recommended):
MINIMUM SUPPLY VOLTAGE = 11.6 + 0.022 (CABLE LENGTH x 0.07) VDC
 For internal only protector (standard with 4-20mA output):
MINIMUM SUPPLY VOLTAGE = 11 + 0.022 (CABLE LENGTH x 0.07) VDC
5. Nominal values may be higher depending upon cable length. Cable resistance = ~70Ω / 1000ft.
6. The drain / shield is connected to the transmitter housing. For lightning protection to function properly (4-20mA only) the shield wire must be connected to a good earth ground!

Acculevel

High Accuracy Submersible Level Transmitter

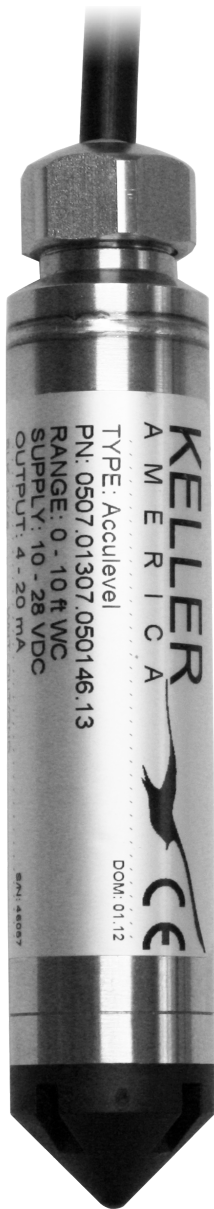

Features:

- 4...20mA models include guaranteed lightning protection at no additional cost.
- 16-bit internal digital error correction for cost-effective low Total Error Band (TEB)
- 316L SS flush-diaphragm sensor standard - Optional titanium for severe applications.
- 2-year warranty covers defects in materials and workmanship.
- User-rangeable analog output ensures compatibility as requirements change.
- RS485 modified-MODBUS compatible allows up to 128 transmitters on a single bus.
- Standard dual (analog & RS485) outputs simplify interface to controls, data collection, and telemetry systems.
- Built in the U.S.A. ARRA Section 1605 Compliant.

Description:

The Acculevel by Keller America provides standard features that far exceed those of comparably priced transmitters, including standard $\pm 0.25\%$ BR or optional $\pm 0.1\%$ Total Error Band (TEB) accuracy.

The ability of the Acculevel to provide this level of sustained performance over a wide range of operating conditions, makes it ideally suited to environmental monitoring applications such as surface water, streams, and reservoirs.

Keller America's guaranteed lightning protection makes this transmitter ideal for installation in areas prone to chronic damage due to transients caused by lightning.

For more information on the Acculevel, or any other Keller product, please contact Keller America, or view the entire Keller catalog at

<http://www.kelleramerica.com/datasheets.html>.

Specifications:

Available ranges _{1,2}		Wetted Materials	Standard 316L S.S.
Relative	Infinite from 0..3 to 0...900ft W.C.		Optional Titanium
Absolute	Infinite from 0...2Bar to 0...11 Bar		Polyamide
Accuracy, TEB ₃	Standard 0.25% BR TEB		Fluorocarbon
	Optional 0.1% BR TEB	Environmental Protection	IP68
Compensated Temp. Range	-10...60C	Cable	Standard Polyethylene
Output	4...20mA + RS485		Optional Hytel
	0...5, 0...10 + RS485		Optional Tefzel
Resolution	0.002% FS	Optional Accessories	Drying Tube
Supply			Aneroid Bellows
Voltage Output	13...28VDC		1/2"NPT Conduit Fitting
Current Output	11...28VDC		Stabilizing Weight
Load Resistance			Termination Enclosure
Current	<(Supply-11V)/0.022A		Open-face nose cap
	>4k ohm		

Specifications and dimensions are subject to change without notice.

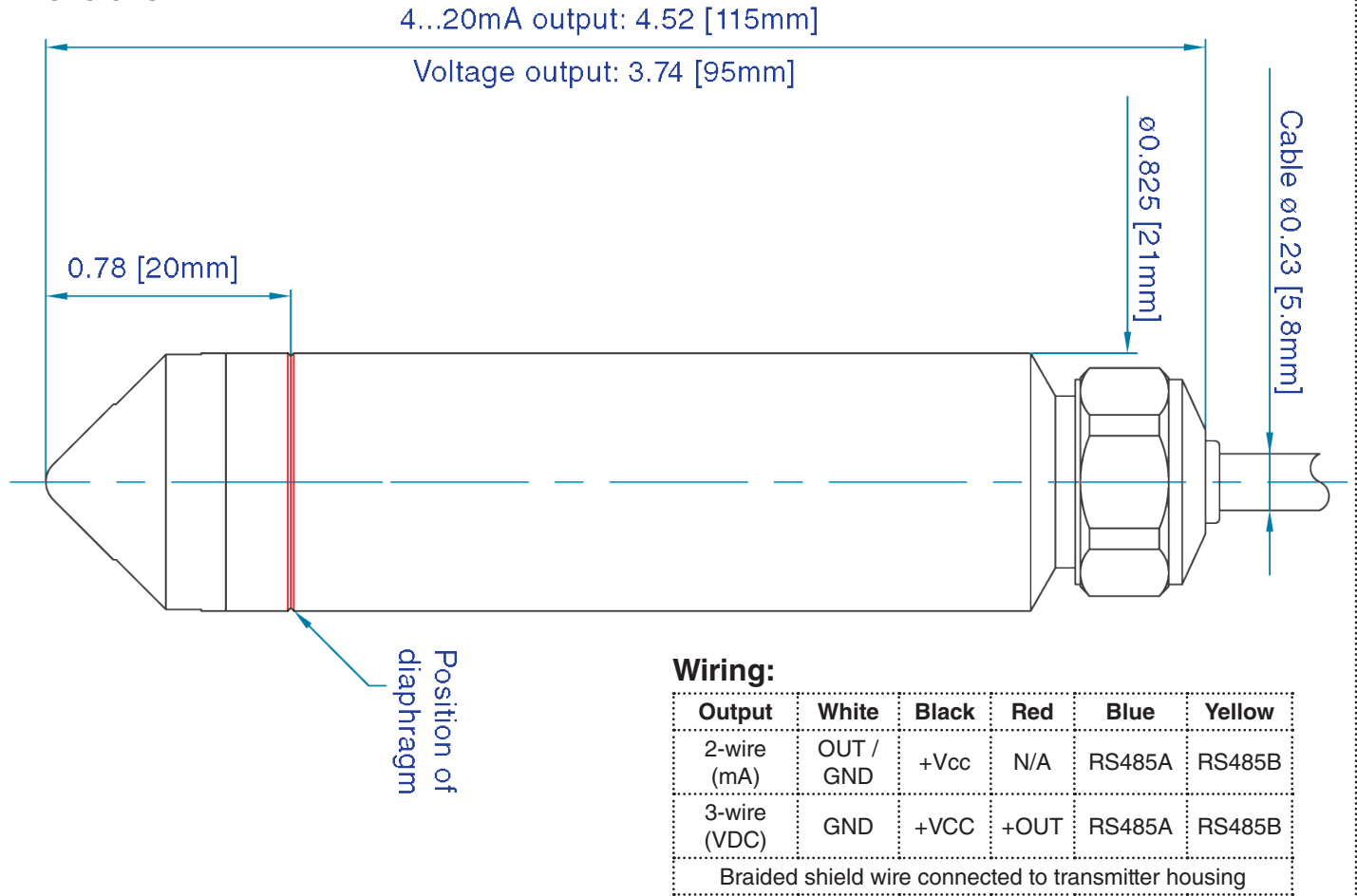
Dimensions:**Notes:**

- The Acculevel can be provided with custom calibration at no extra cost for fluids other than water, provided the specific gravity is given at the time the order is placed.
- Level range may be specified in units of lb/in²(psi), inches WC or feet WC. Keller America uses the International Standard conversion of 2.3067 feet WC/psi.
- Static accuracy includes the combined effects of non-linearity, hysteresis, and non-repeatability at room temperature (25°C). Total Error Band (TEB) includes the combined effects of non-linearity, hysteresis, and non-repeatability as well as thermal dependencies, over the compensated temperature range, expressed as a percentage of the basic range (BR). The calculation for maximum TEB on intermediate ranges (IR) is: $TEB_{IR} = (BR/IR) \times TEB_{BR}$
- Internal lightning protection increases the minimum-required supply voltage, due to internal resistance of the surge protectors. In addition, cable resistance (~70Ω /1000ft) adds to the supply requirement. In order to insure proper system operation, calculate the minimum required supply voltage (at the source) as follows:
 For two-part (internal+external) system (recommended):
MINIMUM SUPPLY VOLTAGE = 11.6 + 0.022 (CABLE LENGTH x 0.07) VDC
 For internal only protector (standard with 4-20mA output):
MINIMUM SUPPLY VOLTAGE = 11 + 0.022 (CABLE LENGTH x 0.07) VDC
- Nominal values may be higher depending upon cable length. Cable resistance = ~70Ω / 1000ft.
- The drain / shield is connected to the transmitter housing. For lightning protection to function properly (4-20mA only) the shield wire must be connected to a good earth ground!

Microlevel

Micro Bore Submersible Level Transmitter



Features:

- Class-leading 0.63" outside diameter
- Built-in surge protection protects the transmitter from fast-rising transients
- 16-bit internal digital error correction for cost-effective low Total Error Band (TEB)
- 316L stainless steel construction
- 2-year warranty covers defects in materials and workmanship.
- User-rangeable analog output ensures compatibility as requirements change.
- RS485 modified-MODBUS compatible allows up to 128 transmitters on a single bus.
- Standard dual (analog & RS485) outputs simplify interface to controls, data collection, and telemetry systems.
- Built in the U.S.A. ARRA Section 1605 Compliant.
- Standard 3 day lead time at no additional charge

Description:

The Microlevel by Keller America is the smallest diameter, media isolated submersible level transmitter in its class. At only 0.63", it is specifically designed for applications that demand small size and high performance.

The Microlevel combines proven piezoresistive silicon sensor technology with Keller's state-of-the-art signal conditioning circuitry to provide outstanding $\pm 0.25\%$ BR standard ($\pm 0.1\%$ optional) Total Error Band (TEB) accuracy over a wide compensated temperature range.

The ability of the Microlevel to achieve this performance day after day, over a wide range of operating conditions, makes it the ideal solution for ground water level measurement and environmental monitoring applications.

For more information on the Microlevel, or any other Keller product, please contact Keller America, or view the entire Keller catalog at:

<http://www.kelleramerica.com/datasheets.html>.

Specifications:

Available ranges _{1,2}		Environmental Protection	IP68
Relative	Infinite from 0.3 to 0...900ft W.C.	Cable	Standard Polyethylene
Accuracy, TEB ₃	Standard 0.25% BR TEB		Optional Hytrel
	Optional 0.1% BR TEB		Optional Tefzel
Compensated Temp. Range	0...50° C	Optional Accessories	Drying Tube
Output	4...20mA + RS485		Aneroid Bellows
Resolution	0.002% FS		Termination Enclosure
Supply	10...30 VDC ₅		Cable Hanger
Load Resistance	<(Supply-10V)/0.02A		Digital Display / Process Controller
Wetted Materials	316L stainless steel		RS485 converter cable
	Polyamide		External surge protector
	Fluorocarbon		

Dimensions:

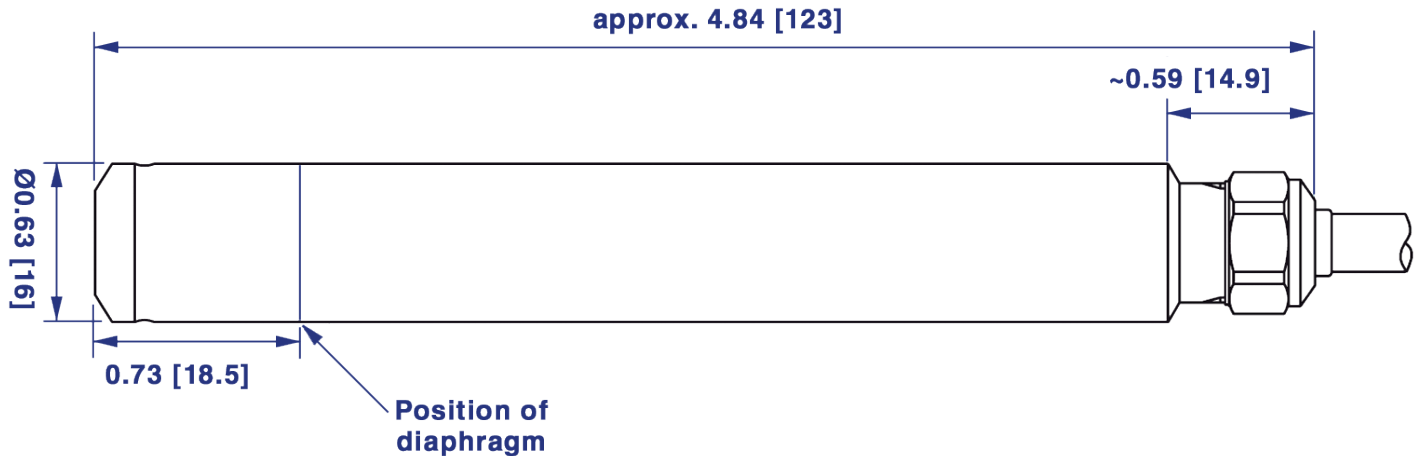

Wiring

Output	White	Black	Red	Blue	Yellow
2-wire (mA)	OUT / GND	+Vcc	N/A	RS485A	RS485B
Braided shield wire connected to transmitter housing ₄					

Notes:

1. The Microlevel can be provided with custom calibration at no extra cost for fluids other than water, provided the specific gravity is given at the time the order is placed.
2. Level range may be specified in units of lb/in²(psi), inches WC or feet WC. Keller America uses the International Standard conversion of 2.3067 feet WC/psi.
3. Static accuracy includes the combined effects of non-linearity, hysteresis, and non-repeatability at room temperature (25°C). Total Error Band (TEB) includes the combined effects of non-linearity, hysteresis, and non-repeatability as well as thermal dependencies, over the compensated temperature range, expressed as a percentage of the basic range (BR). The calculation for maximum TEB on intermediate ranges (IR) is: $TEB_{IR} = (BR/IR) \times TEB_{BR}$
4. The drain / shield is connected to the transmitter housing. For lightning protection to function properly (4-20mA only) the shield wire must be connected to a good earth ground!
5. In addition to 10V minimum supply, cable resistance (~70Ω / 1000ft) adds to the supply requirement. For addition of external surge protection (recommended):
MINIMUM SUPPLY VOLTAGE = 11.25 + 0.025 (CABLE LENGTH x 0.07) VDC

Nanolevel

Submersible Level Transmitter for Very Low Ranges



Features:

- Gold-plated ceramic sensing diaphragm
- 16-bit internal digital error correction for cost effective low Total Error Band (TEB)
- 316L SS housing construction
- 2-year warranty covers defects in materials and workmanship.
- User-rangeable analog output ensures compatibility as requirements change.
- RS485 modified-MODBUS compatible allows up to 128 transmitters on a single bus.
- Standard dual (analog & RS485) outputs simplify interface to controls, data collection, and telemetry systems.
- Built in the U.S.A. ARRA Section 1605 Compliant.
- Standard 3-day lead time at no additional charge

Description:

The Nanolevel from Keller is specifically designed for use in level measurement applications where full scale ranges are less than 10 ft W.C. The Nanolevel's ceramic capacitive sensor technology is proven to provide excellent stability in full scale pressure ranges as low as 4 inches of water.

Perfectly suited for pump control applications and monitoring levels in tanks, weirs, and cooling towers, the Nanolevel is compatible with any standard 2-wire, 4-20 mA current loop that supplies a minimum of 8 but no more than 28 VDC to the transmitter.

For more information on the Nanolevel, or any other Keller product, please contact Keller America, or view the entire Keller catalog at <http://www.kelleramerica.com/datasheets.html>.

Specifications:

Available ranges _{1,2}		Environmental Protection	IP68
Relative	Infinite from 0...4 to 0...120 in. W.C.	Cable	Standard Polyethylene
Accuracy, TEB ₃	Standard 0.25% BR TEB		Optional Hytrel
	Optional 0.1% BR TEB		Optional Tefzel
Compensated Temp. Range	10...50°C	Optional Accessories	Drying Tube
Operating Temp. Range	0...80°C		Aneroid Bellows
Output	4...20mA + RS485		1/2"NPT Conduit Fitting
Resolution	0.002% FS		Cable Hanger
Supply	8...28 VDC ₄		Termination Enclosure
Load Resistance	<(Supply-8V)/0.02A		RS485 Converter Cable
Wetted Materials	Standard 316L S.S.		Digital Display / Process Controller
	Ceramic (gold-plated)		
	Nitrile		
	Fluorocarbon		

Specifications and dimensions are subject to change without notice

Dimensions:

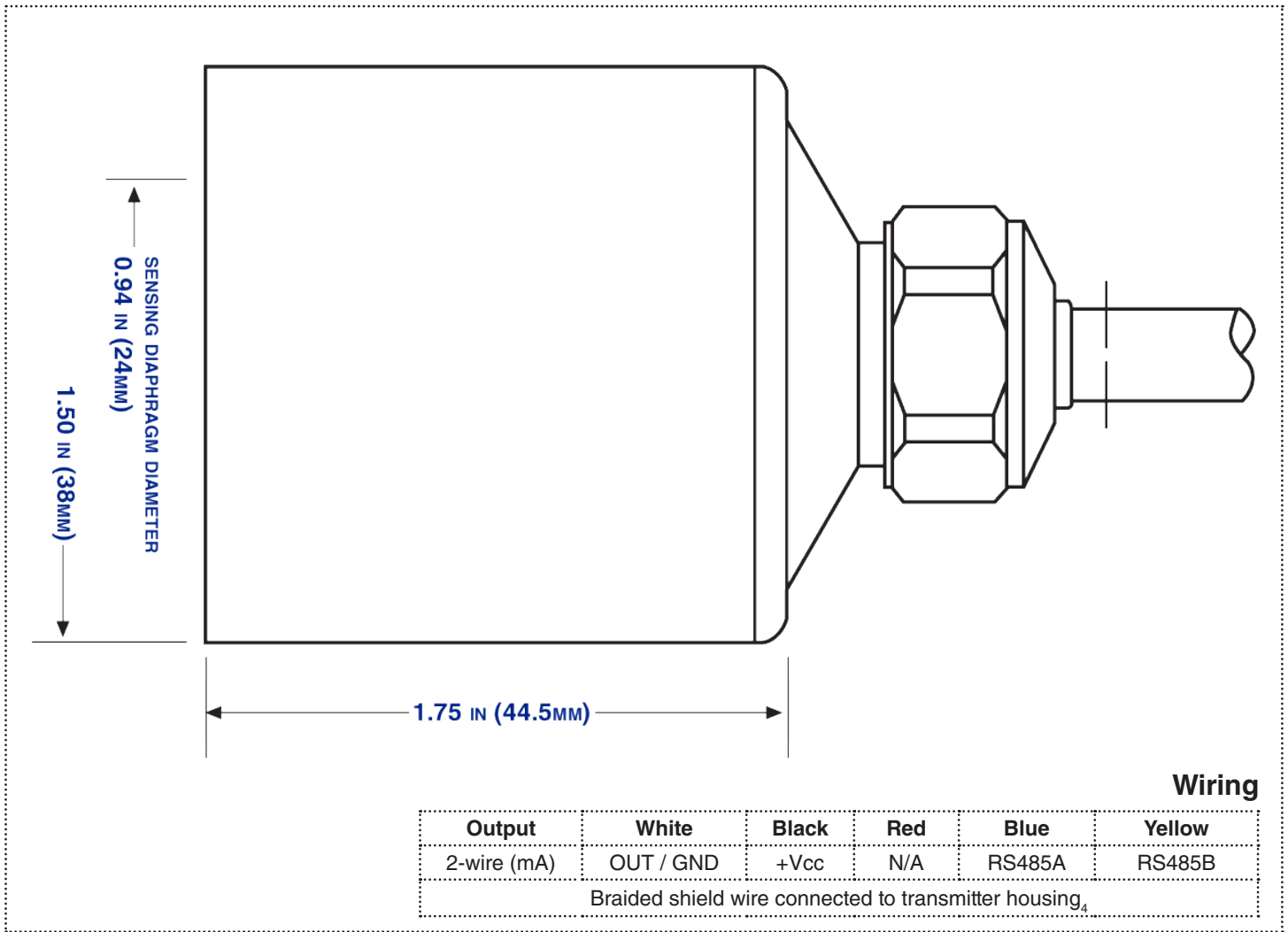

Notes:

1. The Nanolevel can be provided with custom calibration at no extra cost for fluids other than water, provided the specific gravity is given at the time the order is placed.
2. Level range may be specified in units of lb/in2(psi), inches WC or feet WC. Keller America uses the International Standard conversion of 2.3067 feet WC/psi.
3. Static accuracy includes the combined effects of non-linearity, hysteresis, and non-repeatability at room temperature (25°C). Total Error Band (TEB) includes the combined effects of non-linearity, hysteresis, and non-repeatability as well as thermal dependencies, over the compensated temperature range, expressed as a percentage of the basic range (BR). The calculation for maximum TEB on intermediate ranges (IR) is: $TEB_{IR} = (BR/IR) \times TEB_{BR}$
4. Nominal values may be higher depending upon cable length. Cable resistance = ~70Ω / 1000ft.

Digilevel

SDI-12 Submersible Level Transmitter

Features:

- Standard 0.1% FS TEB or optional USGS OSW accuracies available
 - 0.1% FS TEB on ranges up to 900 ft W.C.
 - Meets OSW spec on ranges up to 70 ft W.C.
- 16-bit internal digital error correction for cost-effective low Total Error Band (TEB)
- Multi-stage lightning protection included at no additional cost.
- 316L SS construction standard - Optional titanium for severe applications.₃
- Built in the U.S.A. - ARRA Section 1605 Compliant.
- 2-year warranty covers defects in materials and workmanship.
- Graphical user interface for enhanced setup and communication
 - Intuitive device connection and setup utility
 - Program and save multiple site configurations
 - Live reading mode facilitates on-site setup
 - Emulate modes for Tavis, Design Analysis, and KPSI® Series 500 SDI-12 transmitters₅
 - Terminal mode for SDI-12 command input
 - Enables direct input of slope + offset parameters
 - Several “canned” site parameter scenarios simplify setup

Description:

The Digilevel employs Keller’s proven piezoresistive sensor technology coupled with an SDI-12 serial-digital interface to create a more versatile and valuable tool for environmental level monitoring applications. SDI-12 is a standard communications protocol used to interface microprocessor-based sensors with data recorders for environmental data acquisition.

This convertible instrument may be used for either submersible level or bubbler pressure measurement with user-selectable pressure connection caps. The conical cap is designed to promote automatic cleaning of the sensing diaphragm, helpful where the submersible level transmitter is deployed in high-silt conditions. The optional bubbler transmitter cap provides a 1/8”NPT female pipe thread for connection to the bubbler apparatus.

The Digilevel is ideal for remote applications where battery-powered operation with minimal current draw and networking multiple sensors to a data recorder are required.

The Digilevel is compatible with all SDI-12 v1.3 commands. In addition, it is capable of operating in several emulate modes for popular SDI-12 level/pressure transmitters including manufacturer-specific extended commands. A graphical user interface and Dongle are available options for those who may be unfamiliar with SDI-12 commands.



Specifications:

Accuracy		Wetted Materials	Std. 316L stainless steel
Level	Std. $\pm 0.1\%$ FS ₁		Opt. Titanium ₃
	Opt. ± 0.01 ft when reading ≤ 10 ftWC or $\pm 0.1\%$ of reading > 10 ftWC ₂		Polyamide
Temperature	$\pm 0.5^\circ\text{C}$		Fluorocarbon
Supply Verification	± 0.2 VDC	Electrical Termination	Std. Vented Polyethylene®
Resolution	12-bit		Opt. Hytrel or Tefzel®
Supply	8 - 28 VDC	Protection Rating	IP68
Pressure/temp Output	SDI-12 Version 1.3	Optional Accessories	Desiccant tube
Compensated Temp. Range	Std. $-10 - 60^\circ\text{C}$		1/8" NPT female bubbler cap
	Opt. $0 - 40^\circ\text{C}$ ₂		1/2" NPT male conduit fitting
Available Pressure Ranges	Std. Infinite 0-3 through 0-900 ft W.C.		Stabilizing weight
	Opt. 0-3 through 0-70ft W.C. ₂		Termination enclosure
			Cable hanger
Specifications and dimensions are subject to change without notice			

Dimensions:

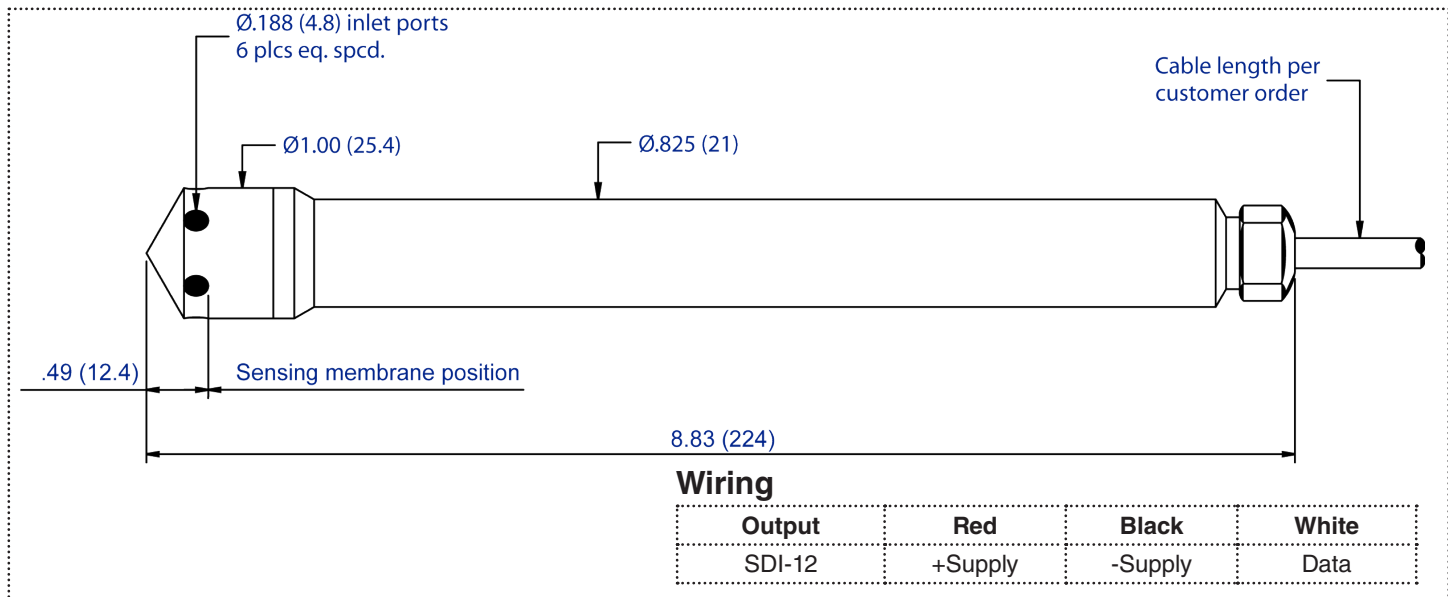

Notes:

1. TEB: Total Error Band; includes the combined effects of non-linearity, hysteresis and non-repeatability as well as thermal dependencies over the compensated temperature range.
2. Optional accuracy is written in compliance with USGS OSW specification mandates.
3. Standard accuracy only. Titanium construction not available for USGS specification.
4. The drain/shield is connected to the transmitter housing. For lightning protection to function properly, the shield wire must be connected to a good earth ground.
5. KPSI®, a Federally-registered trademark, and Series 500, a model designation, are owned by Measurement Specialties, Inc., a maker of level and pressure transducers. All other trademarks are the property of their respective owners.

Specialty

Submersible Level Transmitters

Keller also offers an array of products that are built at the main facility in Switzerland. These instruments use the same precision measurement technologies, but can be provided with additional atmospheric references or safety certifications.

If your applications requires a transmitter option that is not available in the previous pages, these specialty transmitters may provide a solution. Contact Keller or visit www.kelleramerica.com for more information.



26Y Ei - Low-cost Intrinsically Safe Submersible Level Transmitter

- Approved by ATEX standards for use in gas and dust atmosphere
- Available in absolute, sealed, and vented versions
- Current or voltage analog output options
- Pressure ranges up to 20 bar (290 psi)
- 0.7% FS Total Error Band (TEB) accuracy from -10...80° C
- EX-classification:

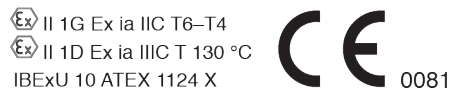

36XW Ei - High Accuracy Intrinsically Safe Submersible Level Transmitter

- Similar specifications as the Acculevel from Keller America
- Approved by ATEX standards for use in hazardous applications
- Available in absolute, sealed, and vented versions
- Current or voltage analog output options + digital RS485
- Pressure ranges up to 30 bar (435 psi)
- 0.15% FS Total Error Band (TEB) analog and 0.1% digital accuracy from -10...80° C
- EX-classification:

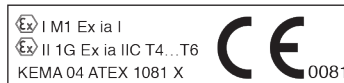

T4 for $T_a \leq 100^\circ\text{C}$, T5 for $T_a \leq 85^\circ\text{C}$, T6 for $T_a \leq 70^\circ\text{C}$



46X Ei - High Accuracy Intrinsically Safe Submersible Transmitter for Low Ranges

- Similar specifications as the Nanolevel from Keller America
- Approved by ATEX standards for use in hazardous applications
- Available in absolute, sealed, and vented versions
- Current or voltage analog output options + digital RS485
- Pressure ranges up to 30 bar (435 psi)
- 0.1% FS Total Error Band (TEB) from 10...50° C
- EX-classification:



PRESSURE TRANSMITTERS

KELLER AMERICA OFFERS SEVERAL ABOVE GROUND PRESSURE TRANSMITTERS, EACH DESIGNED TO PROVIDE THE BEST PRICE, PERFORMANCE, AND VALUE FOR YOUR APPLICATION. EACH OF THESE TRANSMITTERS IS BUILT TO ORDER IN THE U.S. WITH A SHORT, 3-DAY LEAD TIME AND SEVERAL MODELS INCLUDE GUARANTEED LIGHTNING PROTECTION AT NO ADDITIONAL COST.

THE FOLLOWING PAGES WILL PROVIDE PRODUCT-SPECIFIC INFORMATION. HOWEVER, FOR THE MOST CURRENT INFORMATION, PLEASE VISIT WWW.KELLERAMERICA.COM, OR CONTACT A KELLER SALES ASSOCIATE.



Econoline

General Purpose Pressure Transmitter



Features:

- 316L Stainless Steel construction for compatibility with aggressive media
- Full scale ranges from 5 to 10,000 PSI
- 2-year warranty covers defects in materials and workmanship.
- Industry standard outputs simplify interface to controls, data collection, and telemetry systems.
- Built in the U.S.A. ARRA Section 1605 Compliant.
- Standard 3 day lead time

Description:

The Econoline by Keller America is a general purpose pressure transmitter intended for almost any application involving aggressive media and where small size, weight, and low cost are required.

This proven design utilizes a media isolated, piezoresistive silicon sensor, a design known to be highly reliable in thousands of applications around the globe. Combined with state-of-the-art signal conditioning electronics, the result is a robust transmitter that will provide trouble free service and accurate results.

For more information on the Econoline, or any other Keller product, please contact Keller America, or view the entire Keller catalog at:

<http://www.kelleramerica.com/datasheets.html>.

Specifications:

Available ranges		Supply	
Relative	0 - 5, 15, 50, 100, 300 PSIG ₁	4...20 mA Output	8...28VDC
Absolute	0 - 15, 50, 100 PSIA ₁	0.5...4.5 VDC Output	5VDC ₂
Sealed	0 - 300, 500, 1,000, 3,000, 5,000 & 10,000 PSIS ₁	Wetted Materials	Standard 316L S.S. Fluorocarbon
Proof Pressure	Varies by range, 3X for 5 PSI to 1.1X for 10k psi	Process Connection	1/4"-18NPT Male
Static Accuracy	Standard 1% FS max. Optional 0.5% FS max	Electrical Connections	std. 5 ft. PVC Cable or mPm393 with mate
Comp. Temp. Range	-0...50° C	CE-Conformity	EN50081-1, EN50082-2
Operating Temp.	-20...80° C	Shock	20g (11ms)
Thermal Error	0.1% FS / ° C max.	Vibration	20g (5-2KHz, max. amp ±3mm per IEC68-2-6)
Output	4...20mA or 0.5...4.5 VDC	Environmental Protection	IP65
Specifications and dimensions are subject to change without notice			

Dimensions:

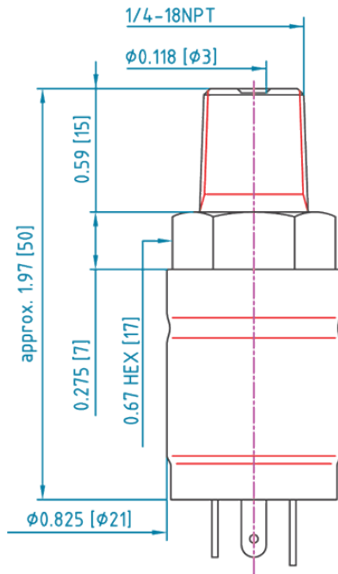

Pressure Range: 5 - 50 PSI
 Drawing: 81350.33
 (w/ cable: 81350.11)

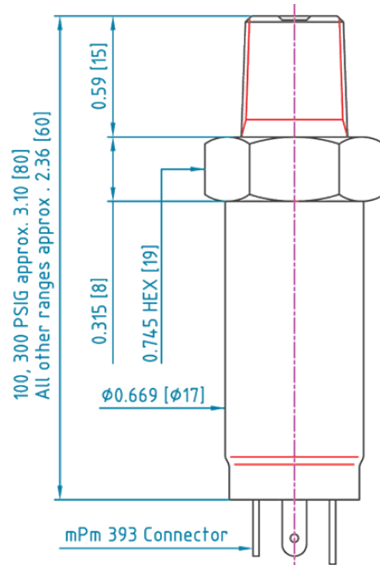

Pressure Range: 100 - 3,000 PSI
 Drawing: 81353.33
 (w/ cable: 81353.11)

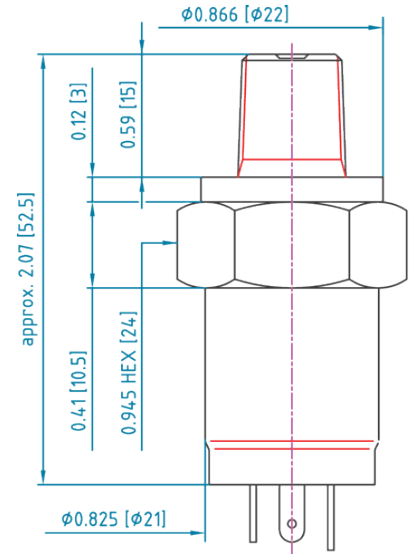

Pressure Range: 5,000 - 10,000 PSI
 Drawing: 81351.33
 (w/ cable: 81351.11)

Wiring

Output	Pin 1 / White	Pin 2 / Red	Pin 3 / Black
2-wire (mA)	OUT / GND	N/A	+Vcc
3-wire (VDC)	GND	+OUT	+Vcc

Notes:

1. PSIG = Gage; Zero-point referenced to local atmospheric pressure.
 PSIA = Absolute; Zero-point set at hard vacuum.
 PSIS = Sealed Gage; Zero-point set at 1 bar absolute (14.504 PSIA).
2. 5VDC supply with 0.5...4.5 VDC ratiometric output only.
3. Dimensions & specifications are subject to change without notice. For the most accurate and up to date information on all products, visit our website.
4. The drain / shield is connected to the transmitter housing. For best \ protection against galvanic corrosion, do not ground.

Valueline

High Accuracy Pressure Transmitter



Features:

- 4...20mA models include guaranteed lightning protection at no additional cost.
- 16-bit internal digital error correction for cost-effective low Total Error Band (TEB)
- 316L stainless steel construction
- 2-year warranty covers defects in materials and workmanship.
- Standard outputs simplify interface to controls, data collection, and telemetry systems.
- Various electrical connections for easy integration into new and existing systems.
- Cabled versions are rated IP68 and suitable for submersion.
- Built in the U.S.A. ARRA Section 1605 Compliant.
- Standard 3-day lead time at no additional charge.

Description:

The Valueline by Keller America provides standard features that far exceed those of comparably priced transmitters by combining proven piezoresistive silicon sensor technology with Keller's state-of-the-art signal conditioning circuitry. The result is outstanding $\pm 0.25\%$ BR standard ($\pm 0.1\%$ optional) Total Error Band (TEB) accuracy over a wide compensated temperature range.

The ability of the Valueline to provide this level of sustained performance over a wide range of operating conditions makes it ideally suited to pressure monitoring applications such as tank level measurement, pump control, and VFD control. Plus, guaranteed lightning protection makes this transmitter ideal for installation in areas prone to chronic damage due to transients caused by lightning.

For more information on the Valueline, or any other Keller product, please contact Keller America, or view the entire Keller catalog at <http://www.kelleramerica.com/data-sheets.html>.

Specifications:

Available ranges		Wetted Materials	Standard 316L S.S., Fluorocarbon
Relative	Infinite from 0...2 to 0...500 PSIG _{1,2}	Process Connection	1/4"-18NPT Male
Absolute	Infinite from 0...2 to 0...500 PSIA _{1,2}	Electrical Connections	std. 10 ft. Cable, DIN43650 ₅ , or mPm393 ₅
Sealed	Infinite from 0...500 to 0...15,000 PSIS _{1,2}	CE-Conformity	opt. MIL-C 26482 ₆
Proof Pressure	Varies by range, 10X for 1 PSI to 1.1X for 15k psi	Shock	EN50081-1, EN50082-2
Accuracy, TEB ₃	Standard 0.25% BR TEB ₃	Vibration	20g (11ms)
	Optional 0.1% BR TEB ₃	Environmental Protection	20g (5-2KHz, max. amp ± 3 mm per IEC68-2-6)
Comp. Temp. Range	-10...80° C	Cable	IP68
Operating Temp. Range	-40...120° C	DIN43650, mPm393	IP65
Output	4...20 mA, 0...5 VDC, 0...10 VDC	MIL-C 26482	IP65
Resolution	0.002% FS	Cable	Std. Polyethylene, opt. Hytrel or Tefzel
Supply		Optional Accessories	Drying Tube
4...20 mA Output	11...28VDC ₄		Aneroid Bellows
0...5 VDC Output	8...28VDC ₄		1/2"NPT Conduit Fitting
0...10 VDC Output	13...28 VDC ₄		Termination Enclosure
Load Resistance			Digital Meter / Process Controller
Current	<(Supply-11V)/0.022A		
Voltage	>4k ohm		

Specifications and dimensions are subject to change without notice.

Dimensions:

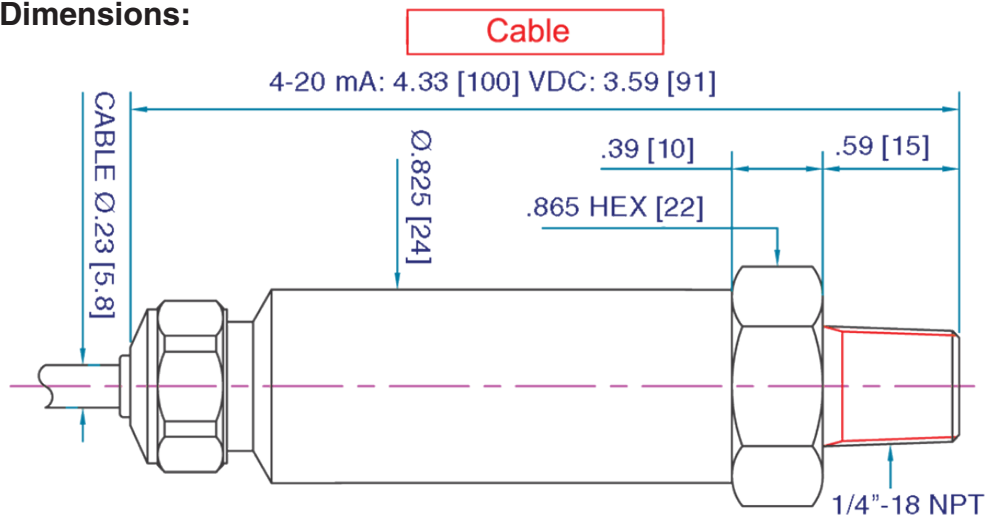

Dimensions in inches [mm]

Wiring

Output,	Pin 1 / C / White	Pin 2 / B / Red	Pin 3 / A / Black
2-wire (mA)	OUT / GND	N/A	+Vcc
3-wire (VDC)	GND	+OUT	+Vcc

Braided shield wire connected to transmitter housing_g

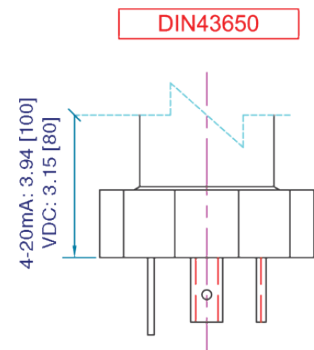

MIL-C-26482

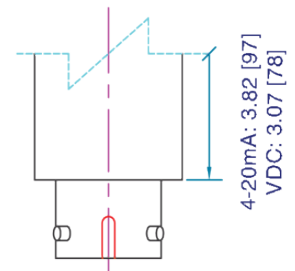

Notes:

- PSIG = Gage; Zero-point referenced to local atmospheric pressure.
PSIA = Absolute; Zero-point set at hard vacuum.
PSIS = Sealed Gage; Zero-point set at 1 bar absolute (14.504 PSIA).
- Zero-point can be suppressed or elevated for special applications.
- Static accuracy includes the combined effects of non-linearity, hysteresis, and non-repeatability at room temperature (25°C). Total Error Band (TEB) includes the combined effects of non-linearity, hysteresis, and non-repeatability as well as thermal dependencies, over the compensated temperature range, expressed as a percentage of the basic range (BR). The calculation for maximum TEB on intermediate ranges (IR) is: $TEB_{IR} = (BR/IR) \times TEB_{BR}$
- Nominal values may be higher depending upon cable length. Cable resistance = $\sim 70\Omega / 1000ft$. Internal lightning protection increases the minimum-required supply voltage, due to internal resistance of the surge protectors. In order to insure proper system operation, calculate the minimum required supply voltage (at the source) as follows:
For two-part (internal+external) system (recommended):
MINIMUM SUPPLY VOLTAGE = 11.6 + 0.022 (CABLE LENGTH x 0.07) VDC
For internal only protector (standard with 4-20mA output):
MINIMUM SUPPLY VOLTAGE = 11 + 0.022(CABLE LENGTH x 0.07) VDC
- Mating connector supplied at no extra cost.
- At extra cost, includes mating connector.
- Pins 1, 2 & 3 refer to the DIN and mPm style connectors. A, B, C... refer to the MIL style connector, and colors refer to the wires inside the cable.
- The drain / shield is connected to the electronic ground. For lightning protection to function properly (4-20mA only) the shield wire must be connected to a good earth ground!

Preciseline

High Accuracy Digital Pressure Transmitter

Features:

- 4...20mA models include guaranteed lightning protection at no additional cost.
- 16-bit internal digital error correction for cost-effective low Total Error Band (TEB)
- 316L stainless steel construction
- 2-year warranty covers defects in materials and workmanship.
- User-rangeable analog output ensures compatibility as requirements change.
- RS485 modified-MODBUS compatible allows up to 128 transmitters on a single bus.
- Standard dual (analog & RS485) outputs simplify interface to controls, data collection, and telemetry systems.
- Built in the U.S.A. ARRA Section 1605 Compliant.
- Standard 3-day lead time at no additional cost.

Description:

The Preciseline by Keller America provides standard features that far exceed those of comparably priced transmitters by combining proven piezoresistive silicon sensor technology with Keller's state-of-the-art signal conditioning circuitry. The result is outstanding $\pm 0.25\%$ BR standard ($\pm 0.1\%$ optional) Total Error Band (TEB) accuracy over a wide compensated temperature range.

The ability of the Preciseline to provide this level of sustained performance over a wide range of operating conditions makes it ideally suited to pressure monitoring applications such as tank level measurement, pump control, and VFD control. Plus, guaranteed lightning protection makes this transmitter ideal for installation in areas prone to chronic damage due to transients caused by lightning.

For more information on the Preciseline, or any other Keller product, please contact Keller America, or view the entire Keller catalog at <http://www.kelleramerica.com/data-sheets.html>.

Specifications:

Available ranges		Wetted Materials	Standard 316L S.S., Fluorocarbon
Relative	Infinite from 0...2 to 0...500 PSIG _{1,2}	Process Connection	1/4"-18NPT Male
Absolute	Infinite from 0...2 to 0...500 PSIA _{1,2}	Electrical Connections	std. 10 ft. Cable, DIN43650 ₅ , or mPm393 ₅
Sealed	Infinite from 0...500 to 0...15,000 PSIS _{1,2}	CE-Conformity	opt. MIL-C 26482 ₆
Proof Pressure	Varies by range, 10X for 1 PSI to 1.1X for 15k psi	Shock	EN50081-1, EN50082-2
Accuracy, TEB ₃	Standard 0.25% BR TEB ₃	Vibration	20g (11ms)
	Optional 0.1% BR TEB ₃	Environmental Protection	20g (5-2KHz, max. amp ± 3 mm per IEC68-2-6)
Comp. Temp. Range	-10...80° C	Cable	IP68
Operating Temp. Range	-40...120° C	DIN43650, mPm393	IP65
Output	4...20 mA, 0...5 VDC, 0...10 VDC	MIL-C 26482	IP65
Resolution	0.002% FS	Cable	Standard Polyethylene
Supply		Optional Accessories	Optional Hytrel or Tefzel
4...20 mA Output	11...28VDC ₄		Drying Tube
0...5 VDC Output	8...28VDC ₄		Aneroid Bellows
0...10 VDC Output	13...28 VDC ₄		RS485 Converter Cable
RS485 Only	std. 8...28 VDC, opt. 3.3...12VDC ₅		1/2"NPT Conduit Fitting
Load Resistance			Termination Enclosure
Current	<(Supply-1V)/0.022A		Digital Meter / Process Controller
Voltage	>4k ohm		

Specifications and dimensions are subject to change without notice.

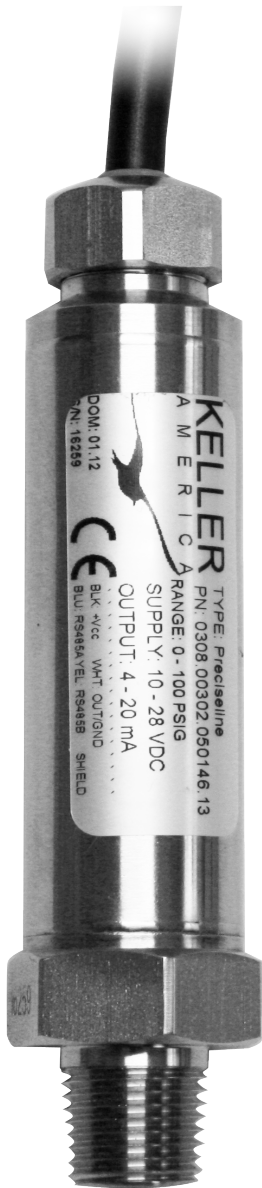

Dimensions:

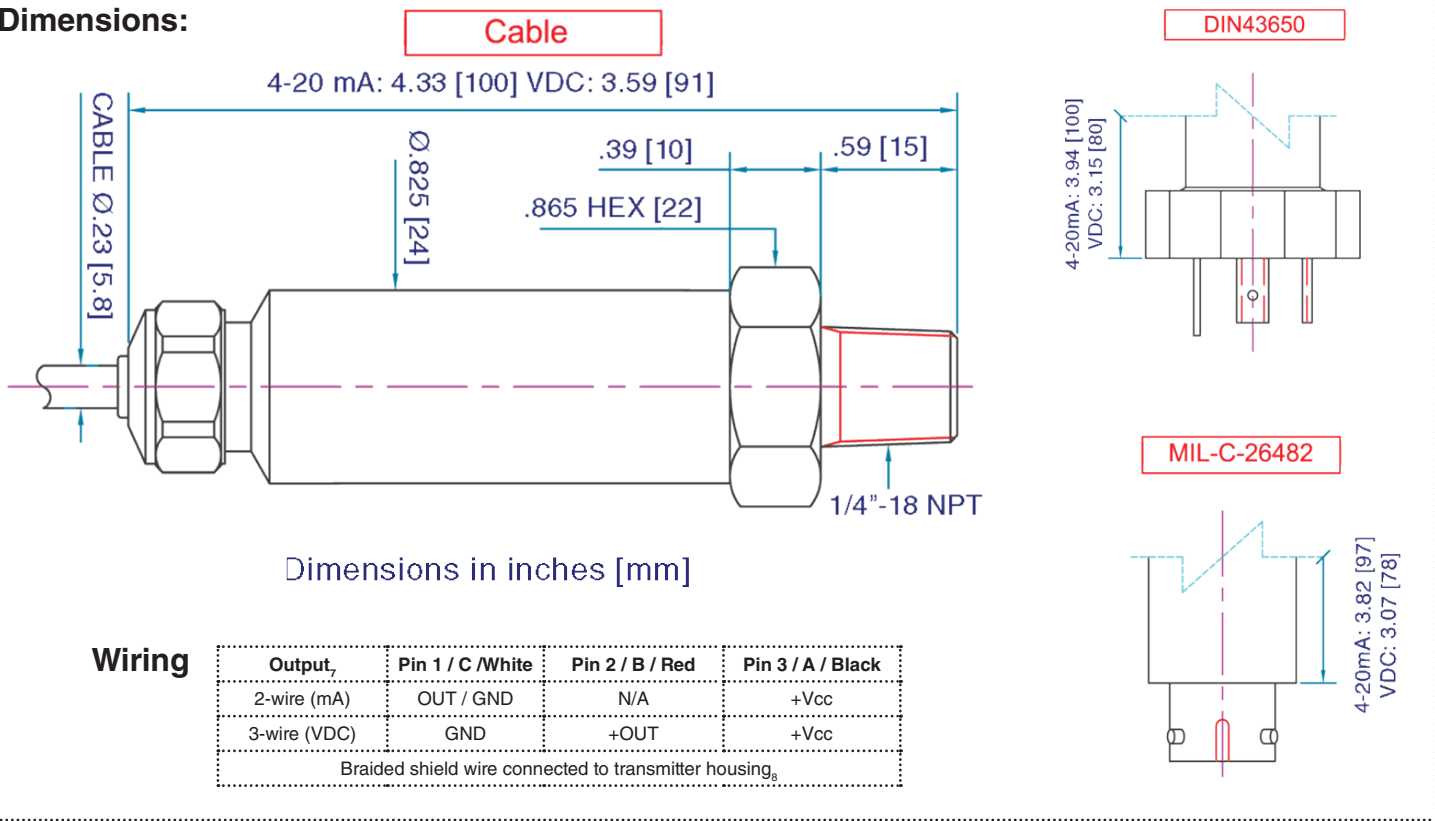

Notes:

1. PSIG = Gage; Zero-point referenced to local atmospheric pressure.
 PSIA = Absolute; Zero-point set at hard vacuum.
 PSIS = Sealed Gage; Zero-point set at 1 bar absolute (14.504 PSIA).
2. Zero-point can be suppressed or elevated for special applications.
3. Static accuracy includes the combined effects of non-linearity, hysteresis, and non-repeatability at room temperature (25°C). Total Error Band (TEB) includes the combined effects of non-linearity, hysteresis, and non-repeatability as well as thermal dependencies, over the compensated temperature range, expressed as a percentage of the basic range (BR). The calculation for maximum TEB on intermediate ranges (IR) is: $TEB_{IR} = (BR/IR) \times TEB_{BR}$
4. Nominal values may be higher depending upon cable length. Cable resistance = ~70Ω / 1000ft. Internal lightning protection increases the minimum-required supply voltage, due to internal resistance of the surge protectors. In order to insure proper system operation, calculate the minimum required supply voltage (at the source) as follows:
 For two-part (internal+external) system (recommended):
MINIMUM SUPPLY VOLTAGE = 11.6 + 0.022 (CABLE LENGTH x 0.07) VDC
 For internal only protector (standard with 4-20mA output):
MINIMUM SUPPLY VOLTAGE = 11 + 0.022(CABLE LENGTH x 0.07) VDC
5. Mating connector supplied at no extra cost.
6. At extra cost, includes mating connector.
7. Pins 1, 2 & 3 refer to the DIN and mPm style connectors. A, B, C... refer to the MIL style connector, and colors refer to the wires inside the cable.
8. The drain / shield is connected to the electronic ground. For lightning protection to function properly (4-20mA only) the shield wire must be connected to a good earth ground!

Specialty

Pressure Transmitters

Keller also offers an array of products that are built at the main facility in Switzerland. These instruments use the same precision measurement technologies, but can be provided with various pressure and electrical connection options, output signals, and safety certifications.

If your applications requires a transmitter option that is not available in the previous pages, these specialty transmitters may provide a solution. Contact Keller or visit www.kelleramerica.com for more information.





21Y - Compact Pressure Transmitter

- Pressure ranges up to 1000 bar
- Available in absolute, sealed, and vented versions
- Current or voltage analog output options
- G1/4", G1/8", or 1/4" NPT male, 7/16"-20 UNF (male or female) Px connections
- M12, Packard, mPm393, or cable electrical connections
- 1.5% FS Total Error Band (TEB) accuracy from -10...80° C
- Excellent EMI protection



23/25Y - Compact Pressure Transmitters

- Pressure ranges from 0...-1 bar up to 0...1000 bar
- Available in absolute, sealed, and vented versions
- Current or voltage analog output options
- Several pressure connection options available (23Y) incl. flush diaphragm (25Y)
- Several electrical connections options
- Excellent EMI protection
- Intrinsically safe (ATEX) versions available
- EX Classification:

 II 1G Ex ia IIC T6-T4
 II 1D Ex ia IIIC T 130 °C
 IIBExU 10 ATEX 1124 X





22 M/S/DT - Low-cost High Volume Pressure Transmitters

- Designed for Automotive and industrial applications
- Operate on 5VDC supply
- Available in absolute and vented versions
- 0,5...4,5 VDC ratiometric output
- Pressure ranges up to 250 Bar (3626 psi)
- 1%, 2%, and 4% FS accuracies available over various temp. ranges
- G1/4", G3/8, M14x1, and 7/16"-20 UNF pressure connections available
- Minimum order quantities apply



23/33X Ed and 25/35X Ed - Pressure Transmitters with Pressure Proof Housing

- Approved by ATEX standards for hazardous applications
- Available in absolute, sealed, and vented versions
- Current or voltage analog + RS485 digital output options
- Pressure ranges up to 300 bar
- 0.2% FS accuracy (23/25Ed) or 0.1% FS accuracy (33/35X Ed)
- EX-classification:



 II 2 G Ex db IIC T6 to T4 LCIE 03 ATEX 6082 X	 0081
---	---

T4 for $T_a \leq 100^\circ\text{C}$, T5 for $T_a \leq 95^\circ\text{C}$, T6 for $T_a \leq 80^\circ\text{C}$



33X/35X- High Precision Pressure Transmitters

- Similar to the Preciseline from Keller America
- Available in absolute, sealed, and vented versions
- Current or voltage analog + digital RS485 output options
- Pressure ranges up to 1000 bar
- 0.1% FS Total Error Band (TEB) accuracy from $-10\text{...}80^\circ\text{C}$
- Intrinsically safe (ATEX) versions available
- EX Classification:

 I M1 Ex ia I  II 1G Ex ia IIC T4...T6 KEMA 04 ATEX 1081 X	 0081
--	---

T4 for $T_a \leq 100^\circ\text{C}$, T5 for $T_a \leq 85^\circ\text{C}$, T6 for $T_a \leq 70^\circ\text{C}$



25/35X HT, HTT, and HTC- High Temperature Pressure Transmitters

- Designed for use in industrial and bio-reactor applications
- Various configurations for operation up to 300
- Available in absolute, sealed, and vented versions
- Current or voltage analog output options + digital RS485 (35X HT/HT/HTT/HTC)
- Pressure ranges up to 30 bar (435 psi)
- 0.15% FS Total Error Band (TEB) analog and 0.1% digital accuracy from $-10\text{...}80$



41X - High Accuracy Pressure Transmitter for Low Ranges

- Various pressure and electrical connection options
- Available in absolute and vented versions
- Current or voltage analog output options + digital RS485
- Pressure ranges up to 300 mbar
- 0.1% FS Total Error Band (TEB) from $10\text{...}50^\circ\text{C}$
- Intrinsically safe (ATEX) versions available
- EX Classification:

 II 1/2 G Ex ia IIC T4 PTB 06 ATEX 2011	 0081
--	---

OPTIONAL ACCESSORIES

KELLER AMERICA OFFERS A VARIETY OF OPTIONAL ACCESSORIES DESIGNED TO ENHANCE VERSATILITY, SIMPLIFY THE INSTALLATION, AND INCREASE THE LONGEVITY OF YOUR KELLER PRESSURE OR LEVEL TRANSMITTER.

THE FOLLOWING PAGES WILL PROVIDE PRODUCT-SPECIFIC INFORMATION. HOWEVER, FOR THE MOST CURRENT INFORMATION, PLEASE VISIT WWW.KELLERAMERICA.COM, OR CONTACT A KELLER SALES ASSOCIATE.



Drying Tube Assembly - Clear tube filled with indicating desiccant, attaches directly to cable vent tube, intercepts water vapor. Highly recommended when operating in high humidity conditions. Must be periodically renewed as desiccant becomes saturated, turning color from blue (dry) to pink (saturated).



Bellows Assembly - Alternative to the drying tube, this aneroid bellows attaches to cable vent tube and requires no periodic maintenance.

Recommended where a slight sacrifice in accuracy can be tolerated.



1/2" NPT Pipe Conduit Fitting - 1/2" NPT male fitting, allows rigid mounting to 1/2" conduit for Levelgage, Acculevel, Digilevel, or LevelRat submersible transmitters. It can also be added to our Preciseline and Valueline pressure transmitters.



Stabilizing Weight - Zinc prop shaft anode adapted to fit Ø21 mm O.D. of Levelgage, Acculevel, and LevelRat submersible level transmitters.

Aids in corrosion resistance as well as helps ensure that the cable remains taut in turbulent conditions.



Cable Hanger - Single eye mesh cord grip style cable hanger for use with Keller's 0.230 inch O.D. cables



Termination Enclosure - Convenient option complementing gauge-type pressure/level transmitters, where it is desired to terminate the transmitter cable close to the measurement point. It includes a NEMA 4X clear front enclosure (7.9 X 4.7 X 3.5 inches) with two, liquid-tight cable fittings (one in, one out), a terminal strip, and provisions for mounting both a drying tube or bellows assembly, each sold separately.



External Surge Protector - Recommended for lightning/surge protection of user's power supply/readout/PLC, etc. To be used in conjunction with Levelgag, Acculevel, LevelRat, Valueline, or Preciseline transmitters.



Titanium Construction - Optional for the Acculevel only and highly recommended for brackish and sea water applications

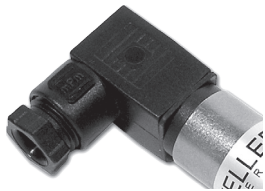

Electrical Connectors - mPm393 is optional for the Econoline, Valueline, and Preciseline. DIN43650 and MIL-C 26482 are optional for Valueline and Preciseline. The mPm393 and DIN43650 incorporate screw terminals, while the MIL-C 26482 mating connectors feature solder cups.



Pressure Test Adapters - These custom built assemblies are designed to facilitate calibration and maintenance testing. Versions are available to connect the Acculevel, Levelgag, LevelRat, and Microlevel to a pressure calibrator.



Digital Display / Process Controller -The Trident series of displays/controllers are ideally suited for use with our line of level and pressure transmitters. Various configurations ensure the right fit for your application.



RS485 Converter/Cable - For the user who wishes to communicate with their Acculevel, Preciseline, Nanolevel, or Microlevel transmitter via the RS485 digital interface. Available in RS232 (serial port) and USB versions, along with cable adapters, as needed, and CCS30 Software (also available for download, free of charge from www.kelleramerica.com). Consult factory for details.



Optional Cable Jacket Materials - Polyethylene (PE) and Tefzel (ETFE) jacketed submersible cable for use on Acculevel, Levelgag, LevelRat, Microlevel, Nanolevel, Digilevel, Preciseline and Valueline transmitters. PE provides the greatest protection from physical damage. Tefzel provides the greatest protection from chemical attack.

AUTONOMOUS LEVEL LOGGERS

KELLER AMERICA OFFERS SEVERAL AUTONOMOUS LEVEL LOGGERS, EACH DESIGNED TO PROVIDE THE BEST SOLUTION FOR YOUR APPLICATION. EACH INSTRUMENT UTILIZES KELLER'S PROVEN PIEZORESISTIVE MEASUREMENT TECHNOLOGY TO ENSURE ACCURATE, RELIABLE RECORDS OF BOTH LEVEL AND TEMPERATURE.

THE FOLLOWING PAGES WILL PROVIDE PRODUCT-SPECIFIC INFORMATION. HOWEVER, FOR THE MOST CURRENT INFORMATION, PLEASE VISIT WWW.KELLERAMERICA.COM, OR CONTACT A KELLER SALES ASSOCIATE.

DCX-22 (SG/VG)

AUTONOMOUS DATA COLLECTOR

The DCX-22 is an autonomous, battery powered instrument made of stainless steel designed to record water depth (pressure) and temperature over long periods. Two versions are offered:

DCX-22 The sensor, electronics and battery are housed in a sealed stainless steel tube, for submersible deployment. For data read-out the DCX-22 must be recovered from the measurement point. The O-ring sealed end cap is then removed to access the data port.

The DCX-22 works with an absolute pressure sensor. In shallow water depths where the influence of barometric pressure changes should be considered, it is recommended that a second data collector DCX-22 (Baro) is placed at the surface, to record the barometric pressure. The PC then calculates the differential pressure resp. the water depth by subtracting the two measured values.

DCX-22 SG/VG The sensor is connected by waterproof cable to a surface mounted housing with the data read-out port. This arrangement allows for easier data recovery from fixed installations. The DCX-22 SG/VG does not have to be removed from the dip pipe for data read out. The DCX-22 SG/VG is supplied with a 2" diameter fixing plate to enable mounting at the top of the dip pipe. The sensor can be sealed gauge SG, or vented gauge VG, the cable carries the vent tube for VG version sensors, vent port in the housing is protected by a breathable Gore-Tex® membrane.

The electronics employ the latest microprocessor technology, which give high accuracy and resolution for the pressure and temperature signals from both the depth sensor and the barometric sensor. The measured values are mathematically compensated for all linearity and temperature errors of the pressure sensors. The use of a non-volatile memory ensures high data security.

The electronics housing is mounted at the top of the borehole to give easy access for data downloading. The level sensor (diameter 22 mm) is connected via a sealed cable to the bottom of the electronics housing. Installation is quick and simple, using fixing devices in various sizes, suitable for cap lock units of different manufacturers and for well access points starting from 1" (caps starting at 2" include a hole to lower a dip meter). Thus enabling measuring stations to be set up at considerably lower costs compared to conventional systems.

The modular design offers the user the two options for collecting the data. Standard design requires the user to visit the location, connect via data-cable and download data. The optional GSM-1 unit allows the transmission of data, and instructions (re-programming) to the data-collector from/to a remote location. The data can be sent to any mobile phone as a short message (SMS).



Version DCX-22



Version DCX-22 SG
DCX-22 VG

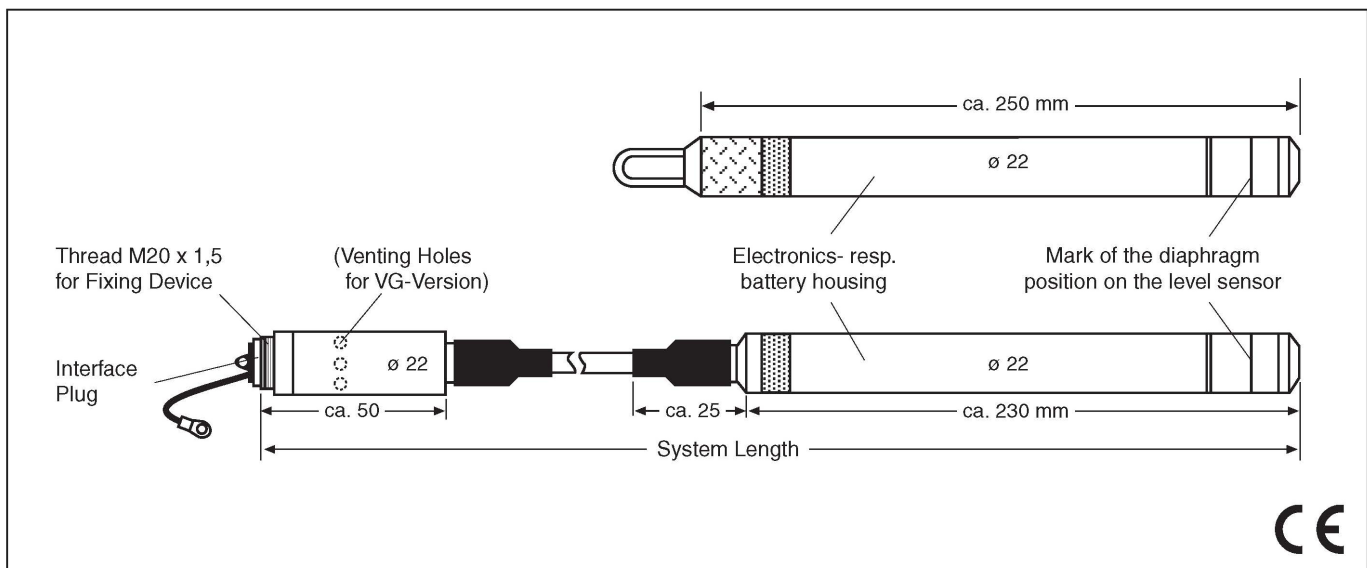

SPECIFICATIONS

Pressure Ranges	DCX-22 Baro	PAA	0,8...1,3 bar				
			<u>10 mWC</u>	<u>20 mWC</u>	<u>50 mWC</u>	<u>100 mWC</u>	
	DCX-22	PAA	0,8...2	0,8...3	0,8...6	0,8...11	bar abs.
	DCX-22 SG	PAA	0,8...2	0,8...3	0,8...6	0,8...11	bar abs.
	DCX-22 VG	PR	1	2	5	10	bar
Overpressure	2 x Pressure Range						

PAA: Absolute, Zero at vacuum PR: Vented Gauge, Zero at atmospheric pressure (other ranges on request)

Supply	Lithium-Battery 3,6 V (Type AA)		Temperature Compensation	-10...40 °C (others on request)
Battery Life *	10 years @ 1 measurement/hour		Temperature Measurement	Accuracy typ. ±0,5 °C
Output	RS 485 digital		Shortest Measuring Range	1x per second
Electrical Connection	Fischer DEE 103A054		Memory	57'000 measuring values @ storage interval ≤ 15 s, otherwise 28'000 measuring values (always with attributed time)
Pressure Sensor Specifications			Material	Stainless steel 316L (DIN 1.4435) O-Ring: Viton®
Linearity	typ. 0,02 %FS		Weight: Probe	≈ 355 g (without cable)
Comp. Temperature Range	-10...40 °C		Tolerance System Length	± 2 cm
Error Band **	typ. 0,05 %FS ***	max. 0,1 %FS	Options	Other pressure connections
Resolution	max. 0,0025 %FS			
Long Term Stability	typ. 0,5 mbar			

* exterior influences could reduce battery life ** Linearity + Temperature Error *** optional max. 0,05 %FS

LOGGER 4.x

The Logger 4.x-Software is delivered along with the interface cable K103A (RS232) or K104A (USB). The software is compatible with Windows (≥ Windows 95) and allows to configure and read out our KELLER data loggers (DCX and Leo Record).

The measuring values may be graphically displayed, exported, air pressure compensated or converted into other units. The Online-function shows the actual values of the instrument. The Logger includes the Reader and Writer.

Writer

The Writer enables the configuration and start of the Logger.

General functions:

- Online display of measuring channels
- Record status indication
- Editing of installation data
- Ring buffer or normal
- Readjustment of the zero

Recording parameter:

- Pressure- and temperature channels selectable

Start methods:

- Time start
- When exceeding or dropping below a certain pressure (or temperature)
- Measuring interval for starting conditions selectable

Recording methods:

- Interval (1s...99 days) and event-controlled recording
- Recording at pressure change
- Turn on or turn off at pressure threshold
- Averaging over selectable number of measurements
- Combination of fixed interval and event recording possible

Reader

The Reader allows the data to be read out into a file. The measured data, which can be converted (exported) into various format, also contains the following information: Serial number, measuring range, sensor name, installation data, read-out data, units, measuring values with date and clock time, read-out date...

General functions:

- Reading of the recordings' directory with starting time and storage size in %
- Read-out of the individual recordings
- Graphical display of the dat
- Record status indication
- Conversion of the data into a text file for Excel import
- Miscellaneous calculations possible

Special calculations or an export of the data into customer specific databases are possible (only on request).

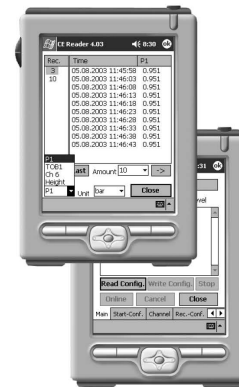
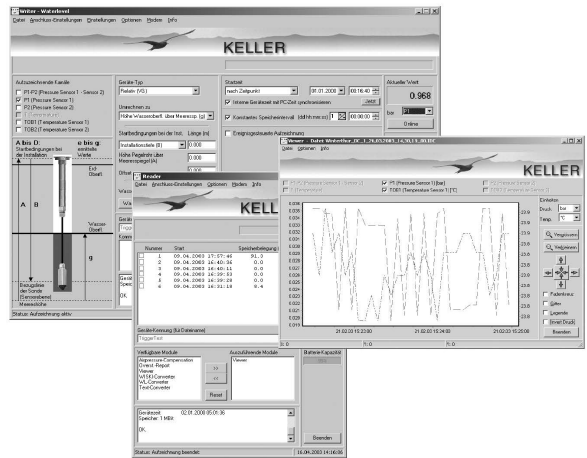

Logger 4.x also includes the WindowsCE-software for PDA's.

DCX-16 (SG/VG)

16mm MICRO-BORE AUTONOMOUS DATA COLLECTOR

The DCX-16 is an autonomous, battery powered instrument. It features a stainless steel 16 mm in diameter housing designed to record water depth (pressure) and temperature over long periods in applications where a more compact size is an advantage.

The electronics employ the latest microprocessor technology which give high accuracy and resolution for the pressure and temperature signals.

The measured values are mathematically compensated for all linearity and temperature errors of the pressure sensors. The use of a non-volatile memory ensures high data security.

Three DCX-16 versions are available:

DCX-16

The sensor, electronics and battery are housed in a sealed stainless steel tube, for submersible deployment. For data read-out the DCX-16 must be recovered from the measurement point. The end cap is then removed to access the data port.

The DCX-16 works with an absolute pressure sensor. In shallow water depths where the influence of barometric pressure changes should be considered, it is recommended that a second data logger (Baro) is placed at the surface, to record the barometric pressure. The PC then calculates the differential pressure resp. the water depth by subtracting the two measured values.

DCX-16 SG/VG

The interface housing is mounted at the top of the borehole to give easy access for data downloading, it is connected via a sealed cable to the electronics housing, which includes the electronic circuit and battery. Installation is quick and simple, using fixing devices in various sizes, suitable for cap lock units of different manufacturers and for well access points starting from 1" (caps starting at 2" include a hole to lower a dip meter). Thus, enabling measuring stations to be set up at considerably lower costs compared to conventional systems.

The logger can be sealed gauge (SG) or vented gauge (VG), the cable carries the vent tube for VG version sensors. The vent port in the housing is protected by a breathable Gore-Tex® membrane.

The modular design allows the user to install the DCX-16 SG/VG with different fixing-plates or to connect it to the GSM-1 module.

The optional GSM-1 unit allows the transmission of data, from the data-collector to a remote location or the data can be sent to any mobile phone as a short message (SMS).



Version DCX-16



Version DCX-16 SG
DCX-16 VG

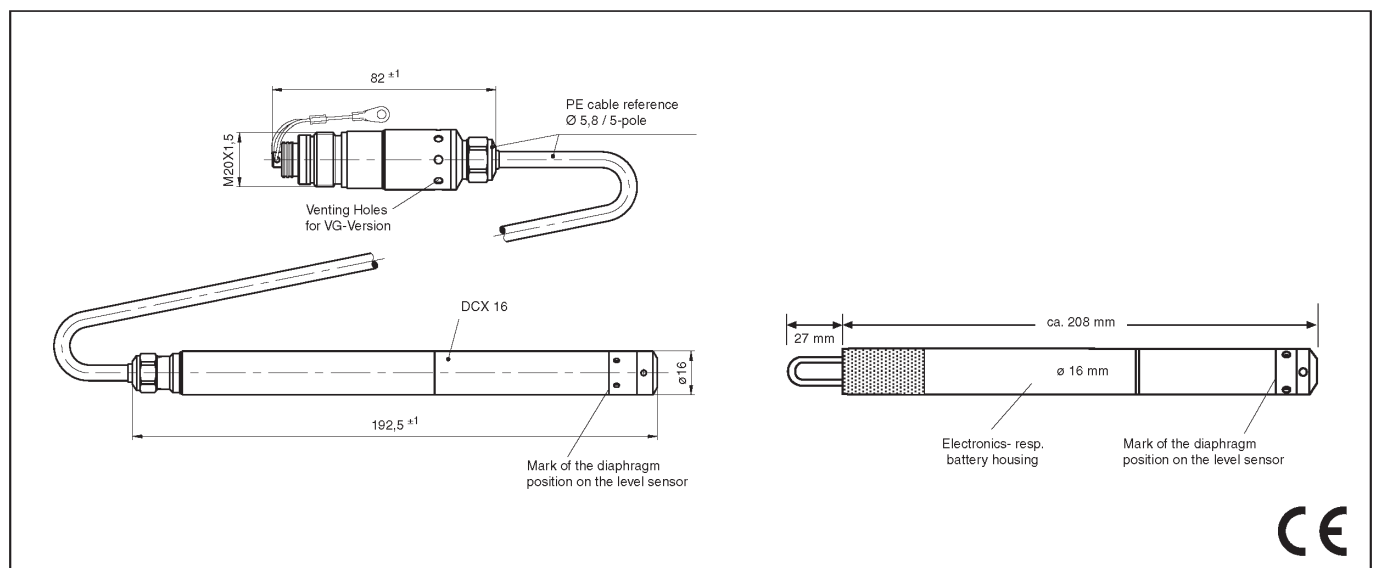

Specifications

Pressure Ranges			10 mWC	20 mWC	50 mWC	100 mWC	
	DCX-16	PAA	0,8...2	0,8...3	0,8...6	0,8...11	bar abs.
	DCX-16 SG	PAA	0,8...2	0,8...3	0,8...6	0,8...11	bar abs.
	DCX-16 VG	PR	1	2	5	10	bar

Overpressure 2 x Pressure Range

PAA: Absolute. Zero at vacuum PR: Vented Gauge. Zero at atmospheric pressure (other ranges on request)

Supply	Lithium battery 3,6 V (Type AAA)	Temperature Compensation	-10...40 °C (others on request)
Battery Life *	4 years @ 1 measurement/hour	Temperature Measurement	Accuracy typ. ±0,5 °C
Output	RS 485 digital	Shortest Measuring Range	1x per second
Electrical Connection	Fischer DEE 103A054	Memory	57'000 measuring values @ storage interval ≤ 15 s, otherwise 28'000 measuring values (always with attributed time)
Pressure Sensor Specifications		Material	Stainless steel AISI 316L O-Ring: Viton®
Linearity	typ. 0,02 %FS	Probe Weight	≈ 150 g (without cable)
Comp. Temperature Range	-10...40 °C	Tolerance System Length	± 2 cm
Error Band **	typ. 0,05 %FS *** max. 0,1 %FS	Options	Other pressure connections
Resolution	max. 0,0025 %FS		
Long Term Stability	typ. 0,5 mbar		

* exterior influences could reduce battery life

** Linearity + Temperature Error

*** optional max. 0,05 %FS

LOGGER 4.x

The Logger 4.x-Software is delivered along with the interface cable K103A (RS232) or K104A (USB). The software is compatible with Windows (≥ Windows 95) and allows to configure and read out our KELLER data loggers (DCX and Leo Record).

The measuring values may be graphically displayed, exported, air pressure compensated or converted into other units. The Online-function shows the actual values of the instrument. The Logger includes the Reader and Writer.

Writer

The Writer enables the configuration and start of the Logger.

General functions:

- Online display of measuring channels
- Record status indication
- Editing of installation data
- Ring buffer or normal
- Readjustment of the zero

Recording parameter:

- Pressure- and temperature channels selectable

Start methods:

- Time start
- When exceeding or dropping below a certain pressure (or temperature)
- Measuring interval for starting conditions selectable

Recording methods:

- Interval (1s...99 days) and event-controlled recording
- Recording at pressure change
- Turn on or turn off at pressure threshold
- Averaging over selectable number of measurements
- Combination of fixed interval and event recording possible

Reader

The Reader allows the data to be read out into a file. The measured data, which can be converted (exported) into various format, also contains the following information: Serial number, measuring range, sensor name, installation data, read-out data, units, measuring values with date and clock time, read-out date...

General functions:

- Reading of the recordings' directory with starting time and storage size in %
- Read-out of the individual recordings
- Graphical display of the dat
- Record status indication
- Conversion of the data into a text file for Excel import
- Miscellaneous calculations possible

Special calculations or an export of the data into customer specific databases are possible (only on request).

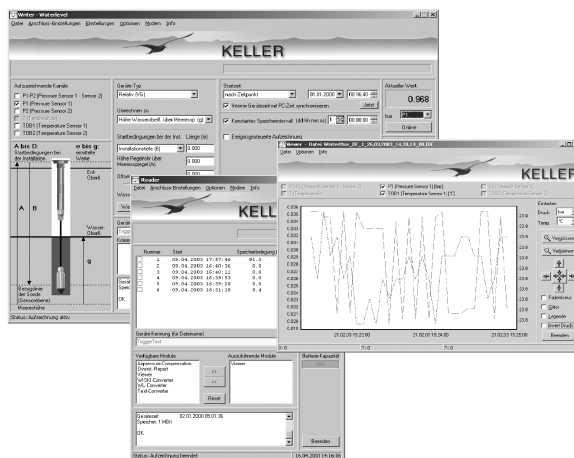

Logger 4.x also includes the WindowsCE- software for PDA's.

DCX-18 ECO

LOW-COST AUTONOMOUS DATA COLLECTOR

The DCX-18 ECO is an autonomous, rechargeable battery powered instrument. It features a stainless steel 18 mm in diameter housing designed to record pressure (water depth) and temperature over long periods at a very economical price. Its small size, rechargeable battery, fully welded housing and the relative sensor option are just a few of the many advantages provided by the DCX-18 ECO.

The electronics employ the latest microprocessor technology which give high accuracy and resolution for the pressure and temperature signals. The measured values are mathematically compensated for all linearity and temperature errors of the pressure sensor.

The use of a non-volatile memory for data storage ensures high data security.

DCX-18 ECO

The sensor, electronics and the rechargeable battery are housed in a fully welded stainless steel tube for submersible deployment. For data read-out, the DCX-18 ECO must be recovered from the measurement point. The end cap, sealed by two O-Rings, must then be removed to access the serial interface.

The DCX-18 ECO works with an absolute pressure sensor. In shallow water depths where the influence of barometric pressure changes should be considered, it is recommended that a second data logger (Baro) is placed at the surface, to record the barometric pressure. The PC then calculates the differential pressure resp. the water depth by subtracting the two measured values.

DCX-18 ECO with cable (DCX-18 ECO SG or DCX-18 ECO VG)

An optional cable is available for the DCX-18 ECO, enabling data retrieval or configuration and charging the battery without removing the data logger. For relative measuring devices, the cable incorporates a capillary tube which enables venting the relative sensor.

Rechargeable Battery:

The DCX-18 ECO is charged over the USB connection with the K-104M converter connected to PC. For fast charging, connect the power supply unit or the car charging adapter to the converter. The charge status is displayed in the logger software.



DCX- 18 ECO



DCX- 18 ECO
with cable

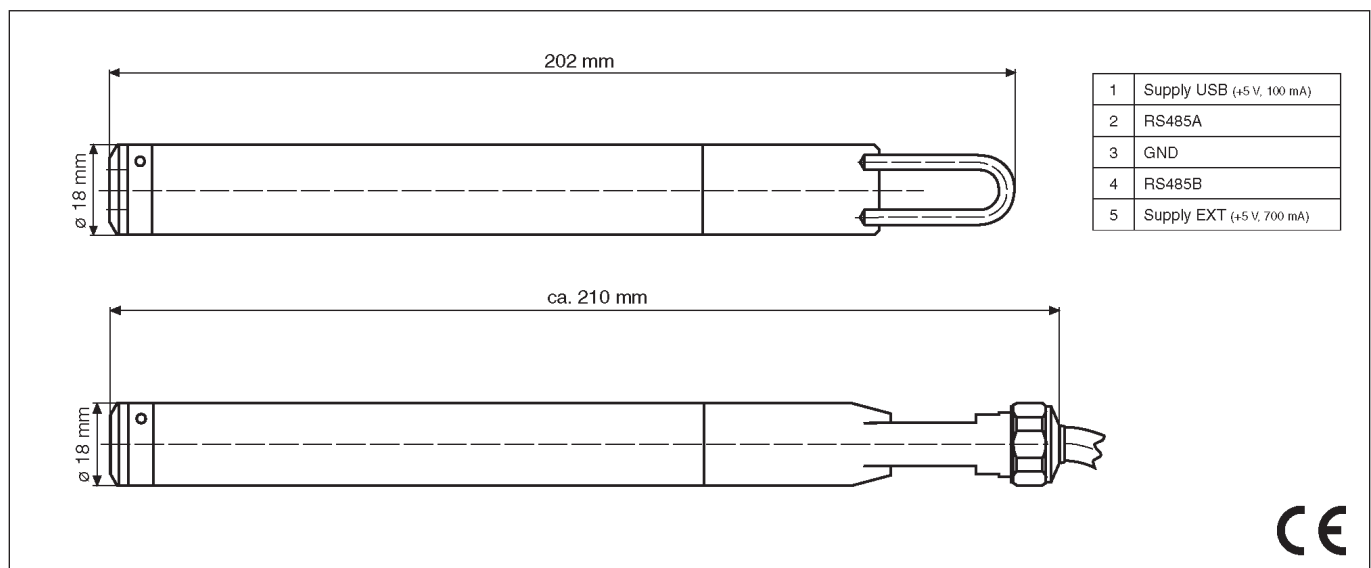

Specifications

Pressure Ranges	PAA 10 mWC (0,8...2 bar)	20 mWC (0,8...3 bar)	50 mWC (0,8...6 bar)	100 mWC (0,8...11 bar)
	PR 10 mWC (0...1 bar)	20 mWC (0...2 bar)	50 mWC (0...5 bar)	100 mWC (0...10 bar)
Overpressure	2 x Pressure Range			

PAA: Absolute, Zero at vacuum PR: Vented Gauge, Zero at atmospheric pressure

Supply	Rechargeable battery	Long Term Stability typ.	Range ≤ 2 bar: 2 mbar (0,02 mWC) Range > 2 bar: 0,2 %FS
Battery Running Time *	~3 years @ 1 measurement/hour	Temperature Measurement	Accuracy typ. ±1 °C
Charging time	~7 h normal charge (USB) ~1 h fast charge (AC/DC or car adapter)	Shortest Measuring Interval	1 per second
Output Interface	RS 485	Memory	57'000 measuring values @ storage interval ≤ 15 s, otherwise 28'000 measuring values (always with attributed time)
Electrical Connection	M12 / 5-pole	Material	Stainless steel AISI 316L O-Ring: Viton® Protective Cap: Delrin®
Cable Option (SG/VG)	Fixed lengths: 10, 20, 50, 100 m	Probe Weight	≈ 150 g (without cable)
Linearity	typ. 0,1 %FS		
Comp. Temperature Range	-10...40 °C		
Error Band **	max. 0,2 %FS		
Resolution	max. 0,0025 %FS		

* external influences could reduce battery capacity

** Linearity + Temperature Error

LOGGER 4.x

The Logger 4.x-software is free available (web download). The software is compatible with Windows (≥ Windows 95) and allows to configure and read out our KELLER data loggers (DCX and Leo Record).

The measuring values may be graphically displayed, exported, air pressure compensated or converted into other units. The Online-function shows the actual values of the instrument. The Logger includes the Reader and Writer and other modules.

Writer

The Writer enables the configuration and start of the Logger.

General functions:

- Online display of measuring channels and battery charge status
- Record status indication
- Editing of installation data
- Ring buffer or normal
- Readjustment of the zero

Recording parameter:

- Pressure- and temperature channels selectable

Start methods:

- Time start
- When exceeding or dropping below a certain pressure (or temperature)
- Measuring interval for starting conditions selectable

Recording methods:

- Interval (1s...99 days) and event-controlled recording
- Recording at pressure change
- Turn on or turn off at pressure threshold
- Averaging over selectable number of measurements
- Combination of fixed interval and event recording possible

Reader

The Reader allows the data to be read out into a file. The measured data, which can be converted (exported) into various format, also contains the following information: Serial number, measuring range, sensor name, installation data, read-out data, units, measuring values with date and clock time, read-out date...

General functions:

- Reading of the recordings' directory with starting time and storage size in %
- Read-out of the individual recordings
- Graphical display of the data
- Record status indication
- Conversion of the data into a text file for Excel import
- Miscellaneous calculations possible

Special calculations or an export of the data into customer specific databases are possible (only on request).



DCX-38 VG

AUTONOMOUS CAPACITIVE DATA COLLECTOR

The DCX-38 VG is an autonomous instrument for recording water level with a high resolution and full scale ranges as low as 0,5 mWC / 50 mbar. It features a rugged, gold-plated ceramic diaphragm for outstanding long-term stability and stainless steel housing with user serviceable battery for long service life.

The internal electronics of the DCX-38 VG employ the latest microprocessor technology, resulting in high accuracy and resolution for pressure measurements. The use of non-volatile memory for data storage ensures high data security.

The DCX-38 VG is based upon a relative pressure sensor and is designed for submersible deployment. Through the use of a vented cable, correction for atmospheric pressure variations is automatic. Therefore, the expense of deploying additional instruments for monitoring barometric pressure is avoided.

The reference pressure tube, integral to the waterproof cable, is protected from moisture intrusion through the use of an optional desiccant tube connected to the adapter nozzle, located in the data port.

The data collector can individually be adjusted to the user's needs and offers the following advantages:

- Recording of the pressure and temperature
- Simple and well structured configuration- and read-out software (Logger 4.x) for PC or PDA
- Combination of event-controlled recording and interval recording prevents unnecessary data being recorded (i.e. only measuring the pressure changes)
- Installation data (and comments) of the measuring station can be stored in the device

Configuration / Data Retrieval:

For data readout, the serial interface is accessed via the data port located on one end of the cable, enabling on site data retrieval. Using either the K-104A or K-103A converter cable, the DCX-38 VG connects easily to a laptop or PC via USB or serial port. Used in conjunction with Logger 4.x software, the DCX-38 VG is configured and data retrieved either in the lab or the field.



Data Port with Desiccant Tube



Capacitive Data Collector

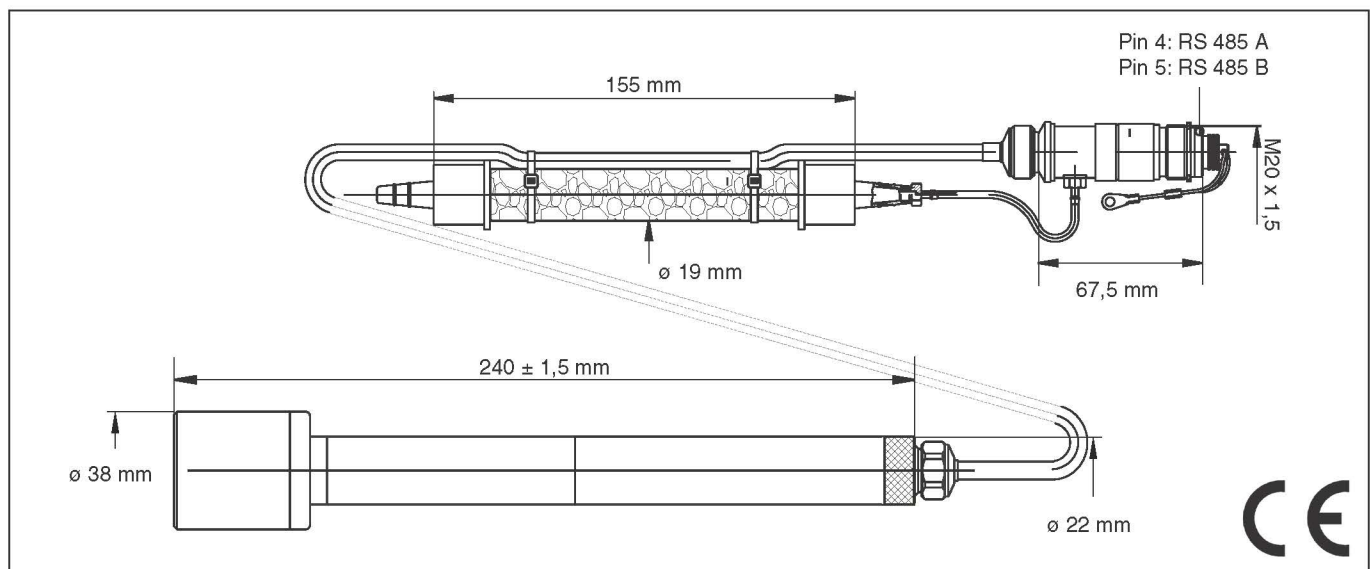

Specifications

Pressure Ranges (PR)	0...50 mbar (0...0,5 mWC)	0...100 mbar (0...1 mWC)	0...300 mbar (0...3 mWC)
Overpressure	10 x Pressure Range	10 x Pressure Range	5 x Pressure Range

PR: Vented Gauge. Zero at atmospheric pressure

Supply	Lithium battery / 3,6V (Type AA)		
Battery Life *	~10 years @ 1 measurement/hour		
Interface	RS 485 digital		
Electrical Connection	Fischer Plug DEE 103A054		
Vented Cable	Standard lengths: 5 m / 10 m (others on request)		
Comp. Temperature Range	-10...40 °C		
Total Error Band **	0,2 %FS		
Resolution	max. 0,002 %FS		
Stability	FS ≥ 100 mbar: ± 0,1 %FS	FS ≤ 100 mbar: ± 0,1 mbar	
Temperature Measurement	Accuracy typ. ±0,5 °C		
Memory	57'000 measuring values @ storage interval ≤ 15 s, otherwise 28'000 meas. values (always with attributed time)		
Shortest Measuring Interval	1 per second		
Material	Diaphragm: Gold-plated Ceramic / Housing: Stainless Steel AISI 316L / O-Ring: Viton		

* external influences could reduce battery capacity

** Linearity + Temperature Error within the compensated range

LOGGER 4.x

The Windows-compatible Logger 4.x-software, if needed, is delivered along with the interface cable or may be downloaded from our web site. It allows to configure and read out KELLER data loggers.

The measuring values may be graphically displayed, exported or converted into other units. The Online-function shows the actual values of the instrument.

The Logger includes the Reader and Writer.

WRITER

The Writer enables the start and configuration of the device.

General functions:

- Online-display of measuring channels
- Status-indication
- Editing of installation data
- Ring buffer record storage or normal
- Readjustment of the zero

Recording parameter:

- Pressure- and temperature channels selectable

Start methods:

- Time start
- When exceeding or dropping below a certain pressure
- Measuring interval for starting conditions selectable

Recording methods:

- Interval (1s...99 days) and event-controlled recording; also combinable
- Recording at pressure change
- Averaging over selectable number of measurements

READER

The Reader allows the data to be read out into a file and to be saved onto a PDA or PC.

The data file, which can be imported by programs such as Excel, contains the following data recorder information: Serial number, measuring range, sensor name, installation data, read-out data, units, measuring values with date and clock time.

General functions:

Status-indication / Reading of the recordings' directory with starting time and storage size in % / Read-out of the individual recordings / Graphical display of the data / Conversion of the data into a text file for Excel import / Miscellaneous calculations possible

Special calculations or an export of the data into customer specific databases are possible (only on request).

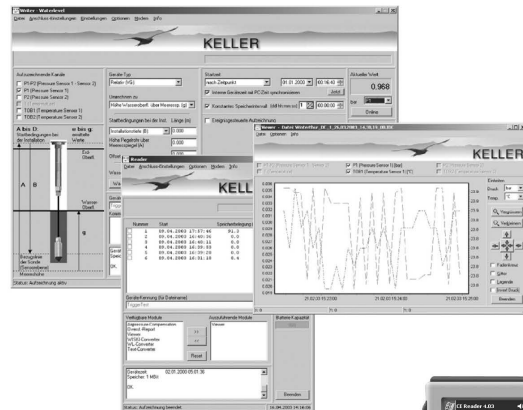

Logger 4.x also includes the Windows Mobile for PDA's.



DCX-25 PVDF

AUTONOMOUS DATA COLLECTOR FOR AGGRESSIVE MEDIA

The DCX-25 PVDF is an autonomous, battery powered instrument designed to record water depth (pressure) and temperature over long periods. The housing is made of polyvinylidene fluoride and the sensing diaphragm is available in either Hastelloy C-276 or titanium 6AL-4V. This combination of wetted materials ensures compatibility with even the most aggressive media.

This data collector (\varnothing 25 mm) integrates a pressure sensor, electronics and battery in one housing. The electronics employ the latest microprocessor technology, which give high accuracy and resolution for the pressure and temperature signals. The built-in pressure sensor is mathematically compensated for all linearity and temperature errors. The use of a non-volatile memory ensures high data security.

The DCX-25 PVDF works with an absolute pressure sensor. For installation, the data collector is secured by a suspension cable and immersed into the media to be measured and must be recovered for data readout. In shallow water, where the influence of barometric pressure changes should be considered, it is recommended that a second data logger (e.g. DCX-22 Baro) is placed at the surface to record the barometric pressure. The Logger PC software then calculates the water depth by subtracting the two measured values. The housing of the data logger can be opened easily without any tools, thus allowing quick access to the replaceable battery and the interface connector for configuration and data download.

Interface with a PC is accomplished using one of Keller's converter cables which are available in either RS232 connection (K103A) or USB connection (K104A). The necessary converter drivers are included with converter purchase, along with the Keller Logger software. This intuitive software provides the capability to customize the instrument, as needed, for each installation. Users can configure the DCX-25 PVDF to record at fixed time intervals, using fixed or event-based start times, in user-selectable measurement methods to ensure that only the most useful and meaningful data is collected and stored.

For applications that do not require highest compatibility with aggressive media, Keller offers the DCX-16, DCX-18, DCX-22 and the DCX-38.

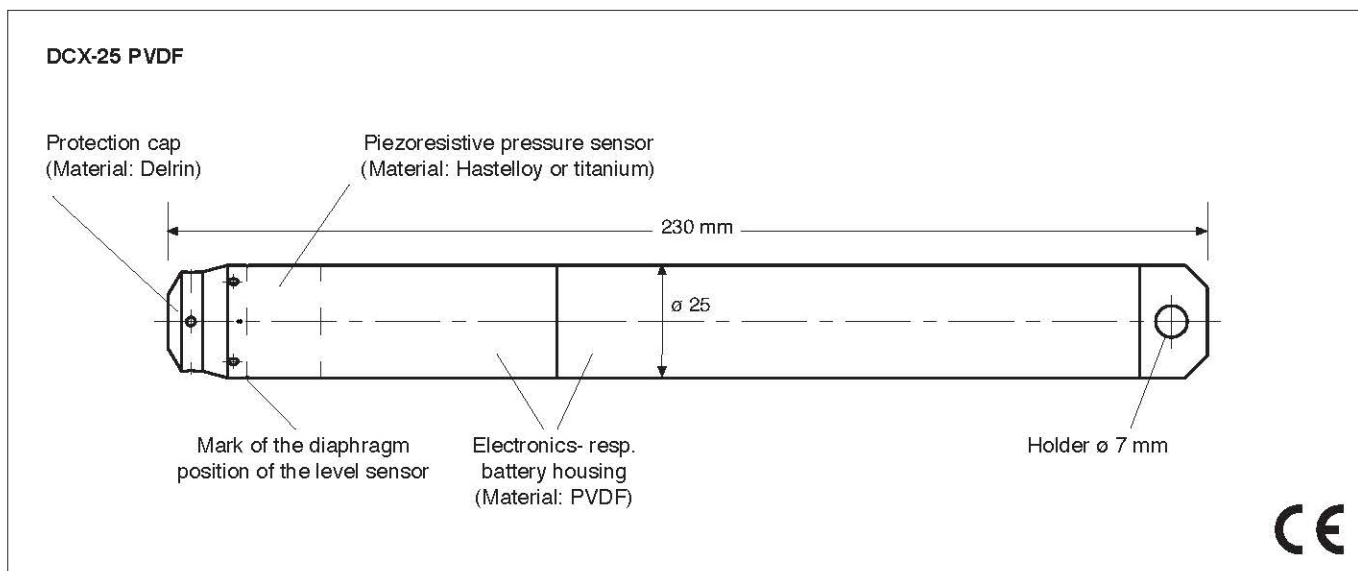

SPECIFICATIONS

Measuring Range in Meter Water Column	<u>10 mWC</u>	<u>20 mWC</u>	<u>50 mWC</u>	<u>100 mWC</u>
Pressure Ranges in bar abs.	0,8...2,3	0,8...3,0	0,8...6,0	0,8...11,0

Supply	Lithium-Battery 3,6 V (Type AA)
Battery Life *	10 years @ 1 measurement/hour
Interface	RS 485
Electrical Connection	Fischer DEE 103A054

Pressure Sensor Specifications

Linearity	typ. 0,02 %FS
Error Band (-10...40 °C)	typ. 0,05 %FS max. 0,1 %FS
Resolution	max. 0,0025 %FS
Long Term Stability	0,1 %FS/year
Overpressure	2 x Pressure Range
Temperature Compensation	-10...40 °C (others on request)

Temperature Sensor

Temperature Measurement via pressure sensor (TOB)	Accuracy typ. ±0,5 °C optional: add. PT 1000 max. ±0,3 °C
---	--

Measuring Channels	Pressure / Temperature (TOB) / Temperature PT 1000 (optional)
Shortest Measuring Range	1x per second
Memory	57'000 measuring values @ storage interval ≤ 15 s, otherwise 28'000 measu- ring values (always with attributed time) (optional: double storage 114'000 / 56'000)

Material

Electronics- / battery housing	PVDF = Polyvinylidenefluoride
O-Rings	Viton® (optional: other materials on request)
Protective Cap	Delrin
Sensor	Hastelloy C276 or titanium (optional)
Weight: Probe	≈ 200 g (without cable)

* exterior influences could reduce battery life

LOGGER 4.x

The Logger 4.x software is included with the purchase of an interface cable K103A (RS232) or K104A (USB) and allows users to configure and read data stored on all Keller data loggers (DCX and LEO Record). The software is compatible with Windows (≥Windows 95).

The measuring values may be graphically displayed, exported in different formats, air pressure compensated or converted into other units. The Online-function shows the actual values of the instrument. The Logger 4.x includes the Reader and Writer, as well as the WindowsCE-software for PDA's.

Writer

The Writer enables the configuration and start of the Logger.

General functions:

- Online display of measuring channels
- Record status indication
- Editing of installation data
- Ring buffer or normal
- Readjustment of the zero

Recording parameter:

- Pressure- and temperature channels selectable

Start methods:

- Time start
- When exceeding or dropping below a certain pressure (or temperature)
- Measuring interval for starting conditions selectable

Recording methods:

- Interval (1s...99 days)
- Combination of fixed interval and event recording possible
- Recording at pressure change
- Recording turn on or turn off at pressure threshold
- Averaging over a selectable number of measurements

Reader

The Reader allows the data to be read out onto the PC. The measured data, which can be converted (exported) into various format, also contains the following information: Serial number, measuring range, sensor name, installation data, read-out data, units, measuring values with date and clock time, read-out date...

General functions:

- Reading of the recordings' directory with starting time and storage size in %
- Read-out of the individual recordings
- Graphical display of the dat
- Record status indication
- Conversion of the data into a text file for Excel import or conversion into other file formats
- Miscellaneous calculations possible

Special calculations or an export of the data into customer specific databases are possible (only on request).

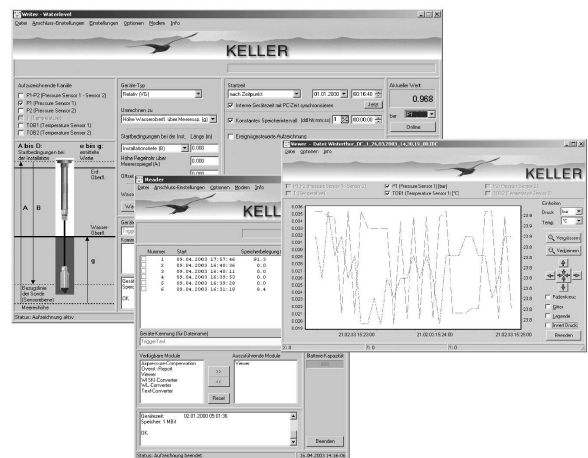

DIGITAL PRESSURE GAUGES

KELLER OFFERS A FULL LINE OF PRESSURE MEASUREMENT INSTRUMENTS, INCLUDING SEVERAL DIGITAL PRESSURE GAUGES. EACH GAUGE UTILIZES KELLER'S PROVEN SENSOR TECHNOLOGY TO PROVIDE ACCURATE, RELIABLE PRESSURE MONITORING.

THE FOLLOWING PAGES WILL PROVIDE PRODUCT-SPECIFIC INFORMATION. HOWEVER, FOR THE MOST CURRENT INFORMATION, PLEASE VISIT WWW.KELLERAMERICA.COM, OR CONTACT A KELLER SALES ASSOCIATE.

LEO-1

DIGITAL MANOMETER WITH PEAK RECORDING

LEO 1 is a micro-processor controlled, accurate and versatile digital pressure measuring instrument with integrated fast peak-, max.- and min.-function.

The instrument is used in two modes:

MANO-Mode

The pressure is measured twice per second and displayed. The top display indicates the actual pressure, the bottom display shows the MAX.- or MIN.- pressure since the last RESET.

PEAK-Mode

The pressure is measured 5'000 times per second and is brought to the display twice per second. The top display shows the actual pressure, the bottom display the peak- (MAX.) or trough-pressure (MIN.).

LEO 1 has two operating keys. The left key is to turn the instrument on, to select the functions and the pressure units. The right key executes the selected function or unit. The right key is also used to switch between the MAX.- and MIN.-value in both modes.

The instrument has the following functions:

RESET With the RESET-function, the MAX.- and MIN.-value is set to the actual pressure value.

ZERO The ZERO-function allows to set any value as a new Zero reference. Barometric pressure variations can thus be compensated. The factory setting of the Zero for the ranges -1...3 bar or -1...30 bar is at 0 bar absolute. For sealed gauge pressure measurements, activate "ZERO SET" at ambient pressure. Instruments with the ranges > 30 bar are calibrated with ambient pressure as a Zero reference.

CONT The instrument turns off 15 Min. after the last key function. Activating CONT (Continuous) deactivates this automatic turn-off.

UNITS All standard instruments are calibrated in bar. The pressure can be indicated in the following units: bar, mbar/hPa, kPa, MPa, PSI, kp/cm²

Optional accessories: - Protective rubber covering (not for Ei-version)
- Carrying bag

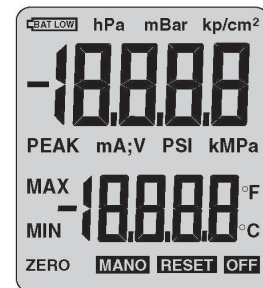

Display Segments LEO 1



SPECIFICATIONS

Pressure Ranges, Resolution, Overpressure:	Range	Resolution	Overpressure
	-1...3 bar	1 mbar	10 bar
	-1...30 bar	10 mbar	60 bar
	0...300 bar	100 mbar	400 bar
	0...700 bar	200 mbar	700 bar
	0...1000 bar	200 mbar	1000 bar
Accuracy RT (room temperature) *	< 0,1 %FS		
Total Error Band (0...50 °C)	< 0,2 %FS		
Storage- / Operating Temperature	-20...70 °C / 0...50 °C		
Compensated Temperature Range	0...50 °C		
Supply	3 V battery, type CR 2430		
Battery Life	<ul style="list-style-type: none"> • 1'000 hours continuous operation in Mano-Mode • 150 hours continuous operation in Peak-Mode 		
Pressure Connection	G1/4"		
Protection, CEI 529	IP65		
Diameter x Height x Depth	76 x 118 x 42 mm		
Weight	≈ 210 g		

* Including linearity, repeatability and hysteresis.

LEO 1 Ei

Intrinsically safe version, 94/9/CE

Classification: **Ex** II 1 G EEx ia IIC T6 or T5
Certification File: LCIE 01 ATEX 6001 X

The EEx ia version of LEO 1 incorporates an additional protection switch.

Functions, ranges and accuracy are identical to the standard version.



LEO-2

DIGITAL MANOMETER WITH MAX AND MIN FUNCTION

LEO 2 is a compact, micro-processor (μ P) controlled, highly accurate and versatile pressure measuring instrument with digital indication. The piezoresistive pressure transducer as the heart of the instrument has gone through extensive pressure- and temperature tests. Its characteristics are stored in the instruments internal EEPROM. The μ P of the LEO 2 reads the characteristic values and calculates therefrom the pressure to an accuracy of $< 0,1$ %FS at room temperature.

The pressure is measured twice per second and displayed. The top display indicates the actual pressure, the bottom display shows the Max.- or Min.- pressure since the last RESET.

LEO 2 has two operating keys. The left key is to turn the instrument on, to select the functions and the pressure units. The right key executes the selected function or unit. The right key is also used to switch between the Max.- and Min.-value.

The instrument has the following functions:

RESET With the RESET-function, the Max.- and Min.-value is set to the actual pressure value.

ZERO The ZERO-function allows to set any value as a new Zero reference. Barometric pressure variations can thus be compensated. The factory setting of the Zero for the ranges $-1...3$ bar or $-1...30$ bar is at 0 bar absolute. For sealed gauge pressure measurements, activate "ZERO SET" at ambient pressure. Instruments with ranges > 30 bar are calibrated in a sealed gauge mode at ambient pressure.

CONT The instrument turns off 15 Min. after the last key function. Activating CONT (Continuous) deactivates this automatic turn-off.

UNITS All standard instruments are calibrated in bar. The pressure can be indicated in the the following units: bar, mbar/hPa, kPa, MPa, PSI, kp/cm^2 .

LEO 2 has 7/16" UNF male thread and is delivered complete with an O-ring seal swivel fitting which allows LEO 2 to be rotated through 360°. Only minimal tightness is needed to seal up to 300 bar. Process pressure connection is G 1/4" male.

Optional accessories: - Protective rubber covering
- Carrying bag



"Swivel"



Adapter G 1/4"

SPECIFICATIONS

Pressure Ranges, Resolution, Overpressure	Range	Resolution	Overpressure
	-1...3 bar	1 mbar	10 bar
	-1...30 bar	10 mbar	60 bar
	0...300 bar	100 mbar	400 bar
	0...700 bar	200 mbar	700 bar

Accuracy RT (room temperature) *	$< 0,1$ %FS
Total Error Band (0...50 °C) *	$< 0,2$ %FS
Storage- / Operating Temperature	-20...70 °C / 0...50 °C
Compensated Temperature Range	0...50 °C
Supply	3 V battery, type CR 2430
Battery Life	1'000 hours continuous operation
Pressure Connection	7/16"-20 UNF (adapter G 1/4" included)
Protection, CEI 529	IP 65
Diameter x Height x Depth	59 x 95 x 32 mm
Weight	≈ 125 g

* Includes linearity, repeatability, hysteresis, temperature error and resolution of the display.
Does not include Zero stability.

LEO 2 Ei

Intrinsically safe version, 94/9/CE (ATEX 100a)

Classification: Ex II 1 G EEx ia IIC T6 or T5
Certification File: LCIE 01 ATEX 6001 X

The EEx ia version of LEO 2 incorporates an additional protection switch. Functions, ranges and accuracy are identical to the standard version.



LEO-3

INTELLIGENT TRANSMITTER WITH DIGITAL INDICATION

LEO 3 is a micro-processor based transmitter with digital double-display for pressure (top display) and for the output signal (bottom display). The display is powered from the 4...20 mA current loop.

The following functions can be executed with the front keys:

MAX/MIN Activating the right key brings the Max.- and Min.-values to the lower display. After 5 seconds, the analog signal is indicated again.

RESET With RESET, the Max.- and Min.-values are set to actual.

ZERO SET The zero is set to the applied pressure.

ZERO RES Restores the instrument back to factory settings.

UNITS The pressure values can be displayed in the following units:
bar, mbar/ hPa, kPa, MPa, PSI, kp/cm².

PROGRAMMING THE ANALOG OUTPUT VIA THE FRONT KEYS

OUTP SETT This sub-menu is used to configure the analog output within the compensated range. The functions can only be accessed by entering a code.

ZERO Executing ZERO when pressure is applied sets the analog output to 4 mA.

FS Executing FS when pressure is applied sets the analog output to 20 mA.

FACT SETT The analog output is set back to factory settings.

PROGRAMMING BY PC

The communication with the BUS-capable instrument takes place with the KELLER READ30/PROG30 software and a KELLER converter (K104B, K107,...) via the RS 485 interface, allowing to read out the pressure values and the instrument characteristics. The analog output can be programmed without applying pressure to the instrument.

Optional accessories: - Protective rubber covering
- Carrying bag



SPECIFICATIONS

Pressure Ranges, Resolution:

	Range	Resolution
PAA	0...4 bar abs.	1 mbar
PAA	0...30 bar abs.	10 mbar
PA	0...300 bar	100 mbar
PA	0...700 bar	200 mbar
PA	0...1000 bar	200 mbar

Accuracy RT (room temperature) *
Total Error Band (0...50 °C)
Storage Temperature
Compensated Temperature Range
Supply
Output
Measuring Rate
Display Rate
Pressure Connection
Electrical Connection
Protection, CEI 529
Diameter x Height x Depth
Weight

< 0,1 %FS
< 0,2 %FS
-10...60 °C
0...50 °C
8...28 VDC
4...20 mA (2 wire) / RS 485
up to 90 times/sec.
2 times/sec.
G1/4"
Binder 723 (back entry)
IP65
76 x 125 x 50 mm
≈ 210 g

* Including linearity, repeatability and hysteresis.

Plug Assignment

Output	Function	Binder 723
4...20 mA (2 wire)	OUT /GND	1
	+Vcc	3
Interface	RS485A	4
	RS485B	5

LEO RECORD

DIGITAL MANOMETER WITH RECORD FUNCTION

LEO Record is an autonomous battery powered instrument with digital display designed to record pressure and temperature over long periods. Both the piezoresistive LEO Record as well as the capacitive LEO Record (ideal for low pressure ranges) offer the following advantages:

- High measuring accuracy, resolution and robustness
- High data security due to the use of a non-volatile memory
- Display of the actual pressure and the record status
- Recording of the pressure and temperature
- Simple and well structured configuration- and read-out software (Logger 4.x) for PC or PDA
- Combination of event-controlled recording and interval recording prevents unnecessary data being recorded (i.e. only measuring the pressure changes...)
- Installation data (and comments) of the measuring station can be stored in the instrument
- Pressure connection with G1/4" thread (other threads on demand)

The pressure is measured and displayed once per second (shortest interval). The top display indicates the actual pressure, the bottom display shows the record status.

All LEO Record versions have two operating keys. The left key is to turn the instrument on, to select the functions and the pressure units. The right key executes the selected function or unit.

The instruments have the following functions:

ZERO The ZERO-function allows to set any value as a new Zero reference.

UNITS All standard instruments are calibrated in bar. The pressure can be indicated in the following units: bar, mbar/hPa, kPa, MPa, PSI, kp/cm², (m)H₂O

RECORD The record can be started or ended with the operating keys.
The configuration of the record takes place via interface/software.

Optional accessories: - Protective rubber covering
- Carrying bag



LEO Record



LEO Record Ei
with capacitive sensor

SPECIFICATIONS LEO Record (Ei)

Pressure Ranges ¹ , resolution, overpressure:	Ranges	Resolution	Overpressure
	-1...3 bar	1 mbar	10 bar
	-1...30 bar	10 mbar	60 bar
	0...300 bar	100 mbar	400 bar
	0...700 bar	100 mbar	700 bar
	0...1000 bar	100 mbar	1000 bar

Total Error Band (0...50 °C) ± 0,1 %FS

SPECIFICATIONS LEO Record (Ei) capacitive

	Standard FS Pressure Ranges ¹			
PR (relative) / PD ² (differential)	30	100	300	mbar
Overpressure	300	1000	1500	mbar
Negative Overpressure	30	100	300	mbar
Total Error Band (10...40 °C)	± 0,2 %FS			
Stability	FS ≥ 100 mbar: ± 0,1 %FS		FS ≤ 100 mbar: ± 0,1 mbar	

¹ Other pressure ranges as well as instruments with relative pressure measuring cells on request

² For the PD-version, a tube connection Ø 6 mm for the reference is available

LEO Record Ei

Intrinsically Safe Version, 94/9/CE

Classification: II 2 G Ex ia IIC T4
Certification File: PTB 05 ATEX 2012 X

The Ex ia version of LEO Record incorporates an additional protection switch.

Functions, ranges and accuracy are identical to the standard LEO Record version.



The factory setting of the zero for the ranges ≤ 61 bar absolute is at vacuum (0 bar absolute). For relative pressure measurements, activate "ZERO SET" at ambient pressure. Instruments > 61 bar absolute or instruments with a relative pressure sensor (label marked with: Range: rel) are calibrated with the zero at atmospheric pressure.

Specifications LEO Record (Ei)

Storage- / Operating Temperature	-10...60 °C / 0...50 °C
Measuring Cycle	Adjustable (shortest interval 1 x per second)
Memory	≈ 57'000 measuring values with time indication @ a measuring cycle of ≤15 s ≈ 28'000 measuring values with time indication @ a measuring cycle of >15 s
Supply	3,6 V Lithium battery, type SL-760
Battery Life	up to 2 years @ 1 recording every 10 seconds
Pressure Connection	G 1/4" (other threads on demand)
Temperature Measurements	Accuracy typ. 0,5 °C
Interface	RS485; rear-sided mating plug "Fischer" compatible with PC-converter cable K103-A (RS232) and K104-A(USB)
Material in Contact with Media	LEO Record: Stainless steel (AISI 316L), Viton® O-ring LEO Record capacitive: Viton® O-ring, gold-coated ceramic diaphragm
Protection	IP 65
Diameter x Height x Depth (approx.)	76 x 120 x 55 mm (LEO Record) / 76 x 150 x 55 mm (LEO Record capacitive)

LOGGER 4.X

The Logger 4.X-software, if needed, is delivered along with the interface cable or may be downloaded from our web site. The software is compatible with Windows 2000/NT/XP/ME and 9X and allows to configure and read out our data loggers (DCX, LEO Record).

The measuring values may be graphically displayed, exported, air pressure compensated or converted into other units. The Online-function shows the actual values of the instrument.

The Logger includes the Reader and Writer.

WRITER

The Writer enables the start and configuration of LEO Record.

General functions:

- Online-display of measuring channels
- Status-indication
- Editing of installation data
- Ring buffer record storage or normal
- Readjustment of the zero

Recording parameter:

- Pressure- and temperature channels selectable

Start methods:

- Time start
- When exceeding or dropping below a certain pressure
- Measuring interval for starting conditions selectable

Recording methods:

- Interval (1s...99 days) and event-controlled recording
- Recording at pressure change
- Averaging over selectable number of measurements
- Combination of fixed interval and event recording possible

READER

The Reader allows the data to be read out into a file and to be saved onto a PDA or PC.

The data file, which can be imported by programs such as Excel, contains the following data recorder information: Serial number, measuring range, sensor name, installation data, read-out data, units, measuring values with date and clock time,...

General functions:

- Status-indication
- Reading of the recordings' directory with starting time and storage size in %
- Read-out of the individual recordings
- Graphical display of the data
- Conversion of the data into a text file for Excel import
- Miscellaneous calculations possible

Special calculations or an export of the data into customer specific databases are possible (only on request).

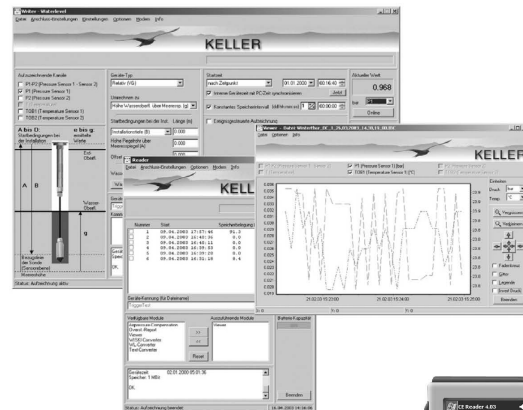

Logger 4.x also includes the WindowsCE-software for PDA's.



LEX-1

HIGH PRECISION DIGITAL MANOMETER

LEX 1 is a micro-processor controlled, accurate and versatile digital pressure measuring instrument with integrated Max./Min.-function for calibration and testing purposes.

The pressure is measured twice per second and displayed. The top display indicates the actual pressure, the bottom display shows the Max.- or Min.-pressure since the last RESET.

LEX 1 has two operating keys. The left key is to turn the instrument on, to select the functions and the pressure units. The right key executes the selected function resp. unit or serves to display the Max.- and Min.-value.



The instrument has the following functions:

RESET: With the RESET-function, the Max.- and Min.-value is set to the actual pressure value.

ZERO: The ZERO-function allows to set any value as a new Zero reference. Barometric pressure variations can thus be compensated.

The factory setting of the Zero for the ranges ≤ 30 bar is at 0 bar absolute. For sealed gauge pressure measurements, activate "ZERO SET" at ambient pressure. Instruments with ranges > 30 bar are calibrated in a sealed gauge mode with ambient pressure as a Zero reference.

CONT: The instrument turns off 15 Min. after the last key function. Activating CONT (Continuous) deactivates this automatic turn-off.

UNITS: All standard instruments are calibrated in bar. The pressure can be indicated in 13 different units.

Optional Accessories:

Carrying bag, protective rubber covering

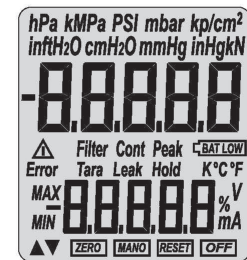

Display 5 Digit LEX 1

SPECIFICATIONS

Pressure Ranges, Resolution, Overpressure:	Range	Resolution	Overpressure
	-1...2 bar	0,1 mbar	3 bar
	-1...20 bar	1 mbar	30 bar
	0...200 bar	10 mbar	300 bar
	0...400 bar	50 mbar	600 bar
	0...1000 bar	100 mbar	1100 bar

Number of Digits	5 Digit
Accuracy (10...30 °C) *	0,05 %FS (including linearity, repeatability and hysteresis)
Precision *	0,05 %FS
Precision optional (≥ 20 bar) *	0,025 %FS / 0,01 %FS
Storage- / Operating Temperature	-10...60 °C / 0...50 °C
Compensated Temperature Range	0...50 °C
Supply	3 V battery, type CR 2430
Battery Life	2000 hours continuous operation
Pressure Connection	G1/4"
Interface	RS485; rear-sided mating plug "Fischer" compatible with PC-converter cable K103-A (RS232) and K104-A (USB)
Protection	IP65
Diameter x Height x Depth	76 x 118 x 42 mm
Weight	210 g

* Accuracy and Precision

"Accuracy" is an absolute term, "Precision" a relative term. Dead weight testers are primary standards for pressure, where the pressure is defined by the primary values of mass, length and time. Highest class primary standards in national laboratories indicate the uncertainty of their pressure references with 70 to 90 ppm or close to 0,01%.

Commercial dead weight testers as used in our facilities to calibrate the transmitters and manometers indicate an uncertainty or accuracy of 0,025 %. Below these levels, KELLER use the expression "Precision" as the ability of a pressure transmitter or manometer to be at each pressure point within 0.01 %FS relative to these commercial standards.

The manometer's full-scale output can be set up to match any standard of your choice by correcting the gain with a calibration software.

OEM SENSORS

TRANSDUCERS & TRANSMITTERS

KELLER IS THE WORLD'S LARGEST INDEPENDENT MANUFACTURER OF MEDIA-ISOLATED, PIEZORESISTIVE PRESSURE SENSORS, PRODUCING IN EXCESS OF 1 MILLION UNITS EVERY YEAR, OFFERING A VARIETY OF OEM PRESSURE SENSORS, TRANSDUCERS, AND TRANSMITTERS THAT ARE DESIGNED TO MEET THE CHANGING DEMANDS IN AUTOMATION, LEVEL MEASUREMENT, AND PRESSURE MONITORING APPLICATIONS. KELLER COMBINES THIS PROVEN PRESSURE MEASUREMENT TECHNOLOGY WITH STATE-OF-THE-ART ELECTRONICS TO PROVIDE FULLY CONDITIONED AND TEMPERATURE COMPENSATED OEM TRANSMITTERS WITH OUTSTANDING RELIABILITY AND ACCURACY OVER TEMPERATURE.

THE FOLLOWING PAGES WILL PROVIDE PRODUCT-SPECIFIC INFORMATION. HOWEVER, FOR THE MOST CURRENT INFORMATION, PLEASE VISIT WWW.KELLERAMERICA.COM, OR CONTACT A KELLER SALES ASSOCIATE.





OEM Pressure Transducers

Media isolated piezoresistive pressure transducers
Unamplified millivolt output with constant current excitation
316L stainless steel construction - other materials available on request
Absolute, sealed-gauge, and vented-gauge versions available
Several size and pressure range configurations available
High and low operation temperatures available



C-Line / D-line OEM pressure transmitters

Fully encapsulated signal conditioning - no external electronics
Excellent EMC resistance
Available pressure ranges up to 1000 bar
Designed for operation on 5 VDC supply
0,5...4,5 VDC ratiometric analog output or I²C digital outputs
Standard $\pm 1\%$ FS TEB accuracy
Standard 316L stainless steel construction - Hastelloy C-276 optional



Y-Line OEM pressure transmitters

External mount PCB
 $\pm 0.3\%$ FS TEB typical accuracy ($\pm 0.5\%$ FS TEB max.)
Available pressure ranges up to 1000 bar
Designed for operation on 8...32 VDC supply
4...20mA, 0...5VDC, 0...10VDC, or 0,5...4,5VDC analog outputs
Standard 316L stainless steel construction - Hastelloy C-276 optional



9LX - Microprocessor-based OEM pressure transmitters

$\pm 0.1\%$ FS TEB max. accuracy from $-10...80^{\circ}\text{C}$
Absolute, sealed-gauge, and vented gauge versions available
Standard pressure ranges: 1, 3, 10, and 30 bar (vented)
2, 4, and 11 bar (absolute)
Custom ranges available on request
4...20mA or 0...10VDC analog outputs plus RS485 digital
Standard 316L stainless steel construction - other material on request

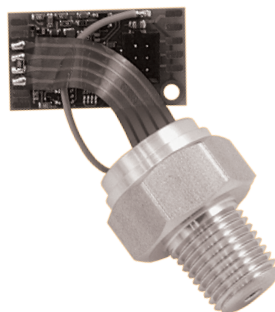

30X - Microprocessor-based OEM pressure transmitters

$\pm 0.1\%$ FS TEB max. accuracy from $-10...80^{\circ}\text{C}$
Absolute, sealed-gauge, and vented gauge versions available
Standard pressure ranges: 1, 3, 10, and 30 bar (vented or absolute)
100, 300, and 1000 bar (sealed)
Custom ranges available on request
Dual outputs - 4...20mA or 0...10VDC analog plus RS485 digital
1/4"-18 NPT male pressure connection
Standard 316L stainless steel construction

USE & CARE

SENSORS, TRANSDUCERS, AND TRANSMITTERS

Safe Handling

Safe handling of KELLER pressure measurement devices is accomplished if a nominal amount of care is taken. Things to avoid are:

- Contact with chemicals known to be corrosive to the materials of construction
- Sharp impact against hard surfaces
- Probing of pressure sensing membrane with ANYTHING

WARNING!

Under no circumstances should the membrane or pressure input port to the KELLER device be probed with any object. Damage to the sensing membrane is permanent and, in most cases, requires repair or replacement.

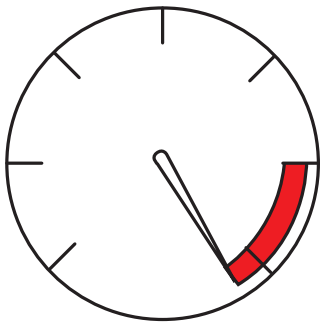
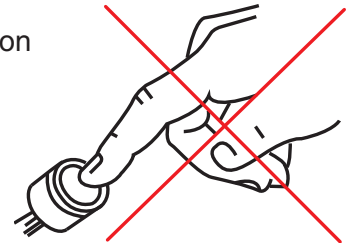

Limits of Pressure

KELLER pressure sensors, transducers and transmitters are designed to withstand a certain amount of overpressure without damage or calibration shift. It can range from 15X for the lower pressure ranges to 1.1X for the highest ranges. This value is different for each product and is referred to in the literature as “Overpressure.” Also found in the literature is usually a value for “Burst Pressure,” which is the pressure at or above which there may be catastrophic failure of the product.

It is the User’s responsibility to insure that the proper KELLER product is chosen for the particular pressure conditions expected.

Environmental conditions

Each KELLER product is designed to be compatible with a particular environment. It is the user’s responsibility to insure that the KELLER product is not exposed to an environmental condition for which it is not designed. These conditions can include operating temperature range and exposure to high-pressure water jets, media not compatible with the materials of construction, submergence of transmitters not designed for that purpose, or potentially explosive atmospheres. A KELLER engineer can help the user determine the correct choice of enclosure to suit the particular application.



Electrical conditions

Each KELLER product is designed to operate properly within a specific range of electrical conditions. All KELLER transmitters are CE-approved and many are Ei (intrinsically safe) or Ex (explosion proof) rated. In addition, several models include guaranteed protection against damage from electrical surge e.g. lightning. The specific product label defines the rating(s), if any, that applies to the product to which it is affixed. It is the User’s responsibility to insure that all electrical connections are made to the KELLER products in accordance with KELLER recommendations. Wire colors or connector pin-outs are either printed on the label affixed to the product or provided separately.

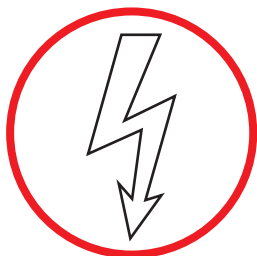

Cleaning

Regarding media-isolated products, should the pressure input to the sensor, transducer or transmitter become fouled, it may be cleaned in the following manner. In the simplest case, and depending upon the specific KELLER product in question, the device should be slowly lowered membrane-first into a solution of warm, soapy water. Care should be taken not to submerge the entire device, unless it is specifically designed for continuous submergence. Agitate the solution with the device and the fouling should disperse after a time. Continue agitating until the input to the device is clear.

Should the fouling be of a nature that it cannot be dissolved with soapy water, use of a solvent is recommended, but only after compatibility with any o-ring seals in the KELLER product is determined. Follow the solvent manufacturer's recommendations for safe handling.

Warranty

Except in the case of special agreements in writing between KELLER and the Customer, the following conditions apply:

Keller America, Inc. warrants that the products that it sells are delivered free from defects in material and workmanship. Keller America, Inc.'s liability under this warranty is limited to replacing or repairing or issuing a credit note, at its option, for any product which is returned to the factory, transportation charges prepaid, and which is determined by Keller America, Inc. to be defective. Suitability for use is the responsibility of the buyer. The above mentioned warranty applies only if the recommended conditions of storage and use are respected by the User.

This warranty does not apply to batteries and accumulators and to any product which has been subjected to or damaged due to misuse, misapplication, negligence or accident, or which has been repaired or altered without express prior and written consent from Keller America, Inc. In order to obtain service under the terms of the warranty, Buyer must notify Keller America, Inc. of any defects before the expiration of the warranty period and make suitable arrangements for the performance of services.

In all cases, Buyer shall be responsible for packaging and shipping the products to the Keller America, Inc. plant with shipping charges prepaid. Keller America, Inc. shall pay for the return of any products to Buyer if the shipment is to a location within the continental USA. Buyer shall be responsible for paying all shipping duties, taxes, and other charges for products returned to any other location. Keller America, Inc. will provide on-site service only upon prior agreement and upon payment of all travel expenses by Buyer.

Warranty period for the Levelgage, LevelRat, Acculevel, Microlevel, Nanolevel, Digilevel, Precise-line, and Valueline products is 24 (twenty-four) months from date of shipment. Warranty period for all other products is 12 (twelve) months from date of shipment. Warranty repair covers all applicable parts and labor. This warranty is given in lieu of any other warranty, express or implied. Keller America, Inc. explicitly disclaims any implied warranties of merchantability and fitness for a particular purpose. KELLER's responsibility is limited to the correct operation of our products and to the repair or replacement of any products which, in our opinion, are deemed to be defective and to which this warranty applies. KELLER is not responsible for indirect loss or damage.

There are no warranties, express or implied, that extend beyond the description herein. The sole and exclusive remedy for any claims against Keller America, Inc. shall be the warranty described in this document. All damages, direct or consequential, limited to the described warranty are excluded.

TERMS

AND CONDITIONS

Offers

Unless otherwise indicated, the prices set forth in this quotation are valid for 60 days from the date of the quotation and apply to products that are scheduled for shipment within twelve months from the date of the Buyer's purchase or at Keller America, Inc. shipping capabilities at the time the order is entered, whichever is later.

Acceptance of order

Any purchase order to be accepted has to refer to a quotation, whether delivered by surface mail, e-mail or facsimile. All oral orders must be confirmed in writing. By referring to this quotation, Buyer accepts and adopts the General Terms and Conditions of Sale ("Terms and Conditions") to the exclusion of any additional or different terms appearing in Buyer's purchase order and waives any right Buyer may have to enforce any such additional or different terms. Our Confirmation of Order or Invoice validates orders. Orders for custom-configured products are built to your specification and therefore may not be canceled once the order has been confirmed.

Date of shipment

The estimated shipping capability stated on the quotation is given solely for the Buyer's information and does not constitute a commitment to deliver products in accordance herewith. Buyer may request a specific shipping date or shipping schedule. Keller America, Inc. will schedule shipments based upon Buyer's request and Keller America, Inc.'s shipping capabilities at the time Buyer's purchase order is processed, at which time Keller America, Inc. will issue to Buyer a formal Acknowledgment of Order that will indicate the estimated shipping date(s). After the shipments have been scheduled, Buyer may not cancel or postpone a scheduled shipment unless Buyer submits its request in writing and Keller America, Inc. consents by issuing a new acknowledgment.

Any request to cancel or to reschedule the shipment that is received less than 21 days from the date scheduled for the shipment of the products covered by the request may be rejected as untimely, or may be accepted upon payment of the cancellation charge of 20% or a rescheduling charge of 10% of the sales price shown on this quotation at Keller America, Inc.'s option. Keller America, Inc. will use its best efforts to ship on or even before the estimated shipping dates indicated, but will not be liable for any delay or failure to deliver. Keller America, Inc. shall not be liable for any special, incidental or consequential damages resulting for delivery delays or inability to deliver.

All goods or materials supplied by Keller America, Inc. remain its property until total payment is received. All such goods and materials are at the sole risk of the Buyer and in the event of being damaged, destroyed or lost after delivery. Keller America, Inc. is entitled to receive the total payment of those goods.

Price

Unless otherwise specified in the quotation, our prices are in US dollars (USD). They are exclusive of freight costs and of all state and local sales, use, excise, privilege and similar taxes. Such taxes imposed on Keller America, Inc. or which Keller America, Inc. has a duty to collect in connection with the sale or delivery of the products described on the quotation shall be paid by Buyer and will appear as separate items on the invoice.

Shipment / freight

Deliveries are F.O.B. Newport News, VA. Title and risk of loss shall pass to Buyer upon tender of the products by Keller America, Inc. to a common carrier. In absence of specific written instruction from Buyer, Keller America, Inc. will select the common carrier, but Keller America, Inc. shall not thereby incur any liability in connection with shipment. Buyer shall be responsible for any freight charge. Declared value for each shipment will be a maximum of \$100 regardless of the actual value of the goods, notwithstanding written instructions from the Buyer specifying a higher declared value. If the products are shipped freight prepaid, Buyer shall pay Keller America, Inc. the appropriate freight charges, which will be shown as separate items on the invoice.

Payment

Terms are indicated on our Confirmation of Order and on our Invoices. Keller America, Inc. will submit an invoice to Buyer for each shipment at the time of shipment. Except as otherwise provided on the quotation, Buyer shall pay the amount invoiced by Keller America, Inc. within 30 days from the date of the invoice. If in the judgment of Keller America, Inc. the financial condition or payment record of Buyer at any time does not justify shipment under the payment terms specified above, Keller America, Inc. may refuse to ship unless it receives payment in advance, or at its option, payment upon delivery. 2% interest per month is charged on overdue accounts.

Documentation

The information given in our documentation, printed matter, data sheets and price lists is without commitment. This information specifies the product but is no warranty, unless agreed in writing.

Warranties

Keller America, Inc. warrants that the products that it sells are delivered free from defects in material and workmanship. Keller America, Inc.'s liability under this warranty is limited to replacing or repairing or issuing a credit note, at its option, for any product which is returned to the factory, transportation charges prepaid, and which is determined by Keller America, Inc. to be defective. This warranty does not apply to batteries and accumulators and to any product which has been subjected to or damaged due to misuse, misapplication, negligence or accident, or which has been repaired or altered without express prior and written consent from Keller America, Inc. In order to obtain service under the terms of the warranty, Buyer must notify Keller America, Inc. of any defects before the expiration of the warranty period and make suitable arrangements for the performance of services. In all cases, Buyer shall be responsible for packaging and shipping the products to the

Keller America, Inc. plant with shipping charges prepaid. Keller America, Inc. shall pay for the return of any products to Buyer if the shipment is to a location within the continental USA. Buyer shall be responsible for paying all shipping duties, taxes, and other charges for products returned to any other location. Keller America, Inc. will provide on-site service only upon prior agreement and upon payment of all travel expenses by Buyer.

Warranty period for the Levelgate, LevelRat, Acculevel, Microlevel, Preciseline, and Valueline products is 24 (twenty-four) months from date of shipment. Warranty period for all other products is 12 (twelve) months from date of shipment. Warranty repair covers all applicable parts and labor. This warranty is given in lieu of any other warranty, express or implied. Keller America, Inc. explicitly disclaims any implied warranties of merchantability and fitness for a particular purpose. There are no warranties, express or implied, that extend beyond the description herein. The sole and exclusive remedy for any claims against Keller America, Inc. shall be the warranty described in this document. All damages, direct or consequential, limited to the described warranty are excluded.

Repairs

Unless otherwise requested in writing by the Buyer, all products returned to Keller America, Inc. under the terms of the warranty will be checked and analyzed in order to determine the cause of the default(s) claimed by the Buyer. A report will then be submitted to the Buyer pointing out the nature of the default(s), the party responsible for the default(s) and the quotation of the repair, if needed. For further repair instructions go to www.kelleramerica.com.

Complaints

All claims or disputes must be made in writing to Keller America, Inc. a maximum of 60 days from receipt of the goods, including discovery of faults not previously apparent. If the warranty claims are justified, Keller America, Inc. is free at its discretion to repair, replace or issue credit. No further compensation for damages will be made. Any disputes or claims of Buyer must be initiated in a proper court or other adjudicative body, as applicable, within one (1) year from the date of shipment by Keller America, Inc., or its representative(s), or such claim shall be deemed invalid or expired and cannot be renewed. To the extent allowed, this limitation period shall trump any applicable statutory limitations period that may state a longer period.

Limitation of responsibility

Our responsibility concerns the correct function of our products only. It cannot be extended to the whole system in which they are used. Our responsibility is limited to the replacement, repair or reimbursement of the goods we agree are defective or non-conforming. The claim must be in writing within 60 days from receipt of the goods.

Place of jurisdiction / applicable law

The contract made by acceptance of this offer shall be deemed made in the State of Virginia and shall be governed by and construed in accordance with the laws of that state without reference to or application of any conflicts of laws principles and without consideration of the place of execution. Buyer expressly agrees to the subject matter and personal jurisdiction of the Circuit Courts for the City of Newport News, Virginia or the federal District Court for the Eastern District of Virginia, Newport News Division.

Assignment

Neither this offer nor any contract resulting there from may be assigned or transferred in whole or part without the prior written consent of Keller America, Inc. No assignment or transfer in violation of this provision shall be valid or binding on Keller America, Inc.

Attorney's fees

Upon any breach of this Agreement, the reasonable attorney's fees and costs of the substantially prevailing party, whether by litigation or settlement, shall be paid by the breaching party.