



PIPE & COUPLING

HOW TO ORDER

Guide To Ordering

- To avoid errors, specify part numbers.
- When selecting regular fittings, size of openings appear in this order:
 - Main
 - Branch or branches
- When selecting reducing/increasing fittings, size appears as illustrated:

Hub & Spigot:

- Spigot of Main
- Hub of Main
- Branch (Branches) or Side Openings
- Length

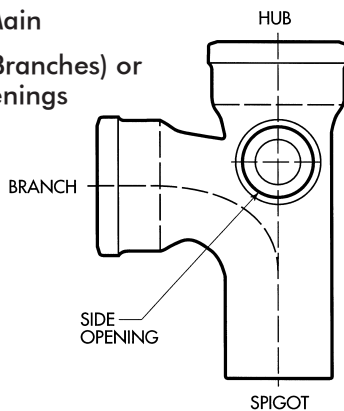

No Hub:

- Bottom Outlet
- Top Inlet
- Branch (Branches) or Side Openings
- Length

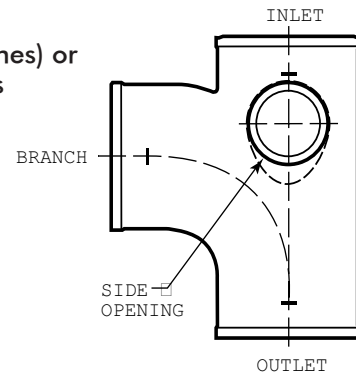

RH (Right Hand) Fittings Illustrated

- When selecting long fittings, long bends are measured from the spigot (outlet) to the centerline of the hub (inlet); long branch fittings are measured from the spigot (outlet) to the base of the hub (inlet).
- To specify right or left side openings, position fittings as follows and read left or right...
 - Bends, face open hub (inlet) with spigot (outlet) down.
 - Branch fittings, face open hub (inlet) of main with branch down.
- All pipe and fittings are furnished coated.

STANDARDS & SPECIFICATIONS

Piping to be installed for the various services shall be as specified or in accordance with local plumbing codes:

CURRENT STANDARDS

♀ NO-HUB® Cast Iron Soil Pipe and Fittings:

CISPI 301 (Cast Iron Soil Pipe Institute)
 ASTM A 888 (American Society for Testing and Materials)

♀ NO-HUB® Couplings

CISPI 310 (Cast Iron Soil Pipe Institute)
 ASTM C 1277 (American Society for Testing and Materials)
 ASTM C 1540 (American Society for Testing and Materials)

SV Hub and Spigot Cast Iron Soil Pipe and Fittings:

ASTM A 74 (American Society for Testing and Materials)

Hub & Spigot Gaskets:

ASTM C 564 (American Society for Testing and Materials)



PIPE & COUPLING

SERVICE FITTINGS

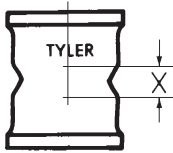

DOUBLE HUB FITTING

Part No.	Size	X
003960	2	1
003977	3	1
003984	4	1
003991	6	1
384755	8	1½
004004	10	1½
384762	12	1½
063711	15	1½

****XH Only; XH Multiplier**

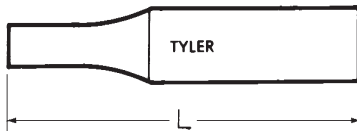

LONG PLAIN INCREASER

Part No.	Size	L
003885	3x4	24
003892	4x5	30

***Not suitable for TY-SEAL Joint.**
****Bead on 4" End.**

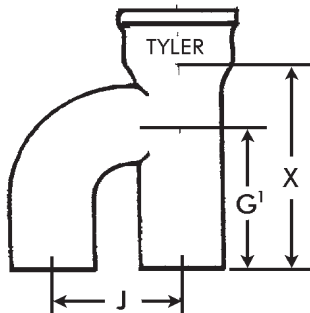

VENT BRANCH

Part No.	Size	X	G'	J
002215	4	11	8	6½

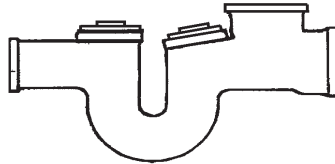

COMBINATION TRAP & TEE with 2 - 3½ A Plugs

Part No.	Size	Tap
112518	4x3	3½

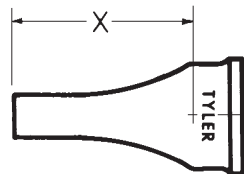

REGULAR INCREASER*

Part No.	Size	X
045939	2x4	9
003809	3x4	9
003816	4x5	9
003823	4x6	9
003830	4x8	12
277248	5x6	9½
003847	6x8	12
384724	8x10	12
003854	10x12	12

***The first size shown is the spigot end.**

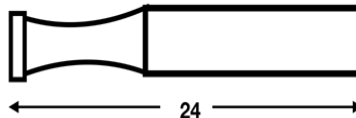

TAPPED LONG INCREASER

Part No.	Size	L
003939	2x4	24

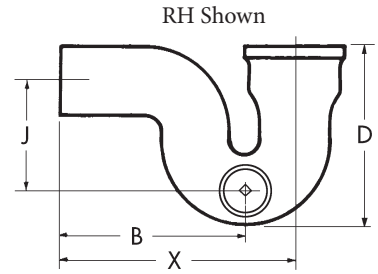

"P" TRAP W/3" CLEANOUT TAP, R, L

Part No.	Size	X	J	B	D
384779	4RH	14	6½	11	5½
384786	4LH	14	6½	11	5½

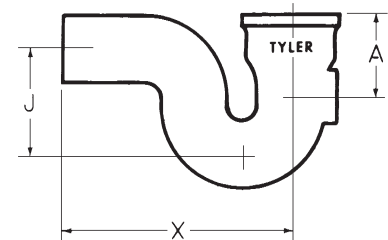

"P" TRAP w/½" HEEL TAP

Part No.	Size	X	J	A
004813	2	9½	4	3
004820	3	12	5½	3½
004837	4	14	6½	3½

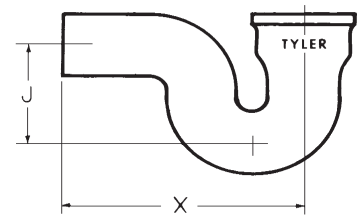

"P" TRAP

Part No.	Size	X	J
004486	2	9½	4
004493	3	12	5½
004509	4	14	6½
004516	5	15½	7½
004523	6	17	8½
004530	8	22½/16	11½