

# INSTALLATION INSTRUCTIONS

## PACKAGE AIR CONDITIONERS

RSNM/RSPM SERIES — (2.0 - 5.0 TONS) FEATURING

NEW INDUSTRY STANDARD R-410A REFRIGERANT: **R410A**



**RECOGNIZE THIS SYMBOL AS AN INDICATION OF IMPORTANT SAFETY INFORMATION!**

### **▲ WARNING**

THESE INSTRUCTIONS ARE INTENDED AS AN AID TO QUALIFIED, LICENSED SERVICE PERSONNEL FOR PROPER INSTALLATION, ADJUSTMENT AND OPERATION OF THIS UNIT. READ THESE INSTRUCTIONS THOROUGHLY BEFORE ATTEMPTING INSTALLATION OR OPERATION. FAILURE TO FOLLOW THESE INSTRUCTIONS MAY RESULT IN IMPROPER INSTALLATION, ADJUSTMENT, SERVICE OR MAINTENANCE POSSIBLY RESULTING IN FIRE, ELECTRICAL SHOCK, PROPERTY DAMAGE, PERSONAL INJURY OR DEATH.



**DO NOT DESTROY THIS MANUAL**

**PLEASE READ CAREFULLY AND KEEP IN A SAFE PLACE FOR FUTURE REFERENCE BY A SERVICEMAN**



# TABLE OF CONTENTS

I. Safety Information .....	3
II. Introduction.....	4
III. Checking Product Received .....	4
IV. Equipment Protection .....	4
V. Specifications .....	4
A. General .....	7
B. Major Components.....	7
C. R-410A Refrigerant .....	7
1. Specifications of R-410A.....	7
2. Quick Reference Guide for R-410A .....	7
3. Evaporator Coil / TXV .....	7
4. Tools Required for Installing & Servicing R-410A Models .....	7
VI. Installation .....	8
A. General .....	8
1. Pre-Installation Check Points .....	8
2. Location.....	8
B. Outside Slab Installation .....	8
C. Clearances .....	8
D. Rooftop Installation .....	8
VII. Ductwork.....	9
VIII. Filters.....	10
IX. Condensate Drain, Indoor Coil .....	10
X. Electrical Wiring.....	10
A. Power Wiring.....	10
B. Electric Heater Kit Instructions .....	11
C. Control Wiring .....	11
D. Internal Wiring.....	12
E. Grounding .....	12
F. Thermostat .....	12
XI. Indoor Air Flow Data.....	12
Indoor Airflow Performance.....	13-16
XII. Pre-Start Check .....	17
XIII. Startup .....	17
XIV. Operation.....	18
A. Control System Operation.....	18
XV. General Data .....	19-24
XVI. Miscellaneous	
Electrical Data .....	25-26
Heater Kit Characteristics.....	27-30
Wiring Diagrams.....	31-36
Charge Charts .....	37-42
Troubleshooting.....	43

► Installation instructions are updated on a regular basis. This is done as product changes occur or if new information becomes available. In this publication, an arrow (►) denotes changes from the previous edition or additional new material.

# I. SAFETY INFORMATION

## WARNING

PROPOSITION 65: THIS APPLIANCE CONTAINS FIBERGLASS INSULATION. RESPIRABLE PARTICLES OF FIBERGLASS ARE KNOWN TO THE STATE OF CALIFORNIA TO CAUSE CANCER.

## WARNING

THE MANUFACTURER'S WARRANTY DOES NOT COVER ANY DAMAGE OR DEFECT TO THE AIR CONDITIONER CAUSED BY THE ATTACHMENT OR USE OF ANY COMPONENTS, ACCESSORIES OR DEVICES (OTHER THAN THOSE AUTHORIZED BY THE MANUFACTURER) INTO, ONTO OR IN CONJUNCTION WITH THE AIR CONDITIONER. YOU SHOULD BE AWARE THAT THE USE OF UNAUTHORIZED COMPONENTS, ACCESSORIES OR DEVICES MAY ADVERSELY AFFECT THE OPERATION OF THE AIR CONDITIONER AND MAY ALSO ENDANGER LIFE AND PROPERTY. THE MANUFACTURER DISCLAIMS ANY RESPONSIBILITY FOR SUCH LOSS OR INJURY RESULTING FROM THE USE OF SUCH UNAUTHORIZED COMPONENTS, ACCESSORIES OR DEVICES.

## WARNING

DISCONNECT ALL POWER TO THE UNIT BEFORE STARTING MAINTENANCE. FAILURE TO DO SO CAN RESULT IN SEVERE ELECTRICAL SHOCK OR DEATH.

## WARNING

UNITS ARE NOT DESIGN CERTIFIED TO BE INSTALLED INSIDE THE STRUCTURE. DOING SO CAN CAUSE INADEQUATE UNIT PERFORMANCE AS WELL AS PROPERTY DAMAGE AND CARBON MONOXIDE POISONING RESULTING IN PERSONAL INJURY OR DEATH.

## WARNING

DO NOT, UNDER ANY CIRCUMSTANCES, CONNECT RETURN DUCTWORK TO ANY OTHER HEAT PRODUCING DEVICE SUCH AS A FIREPLACE INSERT, STOVE, ETC. UNAUTHORIZED USE OF SUCH DEVICES MAY RESULT IN FIRE, CARBON MONOXIDE POISONING, EXPLOSION, PROPERTY DAMAGE, SEVERE PERSONAL INJURY OR DEATH.

## WARNING

THE UNIT MUST BE PERMANENTLY GROUNDED. A GROUNDING LUG IS PROVIDED IN THE ELECTRIC HEAT KIT FOR A GROUND WIRE. FAILURE TO GROUND THIS UNIT CAN RESULT IN FIRE OR ELECTRICAL SHOCK CAUSING PROPERTY DAMAGE, SEVERE PERSONAL INJURY OR DEATH.

## WARNING

ONLY ELECTRIC HEATER KITS SUPPLIED BY THIS MANUFACTURER AS DESCRIBED IN THIS PUBLICATION HAVE BEEN DESIGNED, TESTED, AND EVALUATED BY A NATIONALLY RECOGNIZED SAFETY TESTING AGENCY FOR USE WITH THIS UNIT. USE OF ANY OTHER MANUFACTURED ELECTRIC HEATERS INSTALLED WITHIN THIS UNIT MAY CAUSE HAZARDOUS CONDITIONS RESULTING IN PROPERTY DAMAGE, FIRE, BODILY INJURY OR DEATH.

## WARNING

DISCONNECT MAIN ELECTRICAL POWER TO THE UNIT BEFORE ATTEMPTING TO CHANGE BLOWER SPEEDS. FAILURE TO DO SO MAY RESULT IN ELECTRICAL SHOCK OR SEVERE PERSONAL INJURY OR DEATH.

## CAUTION

R-410A systems operate at higher pressures than R-22 systems. Do not use R-22 service equipment or components on R-410A equipment.

## WARNING

**IMPORTANT: ALL MANUFACTURER PRODUCTS MEET CURRENT FEDERAL OSHA GUIDELINES FOR SAFETY. CALIFORNIA PROPOSITION 65 WARNINGS ARE REQUIRED FOR CERTAIN PRODUCTS, WHICH ARE NOT COVERED BY THE OSHA STANDARDS.**

**CALIFORNIA'S PROPOSITION 65 REQUIRES WARNINGS FOR PRODUCTS SOLD IN CALIFORNIA THAT CONTAIN, OR PRODUCE, ANY OF OVER 600 LISTED CHEMICALS KNOWN TO THE STATE OF CALIFORNIA TO CAUSE CANCER OR BIRTH DEFECTS SUCH AS FIBERGLASS INSULATION, LEAD IN BRASS, AND COMBUSTION PRODUCTS FROM NATURAL GAS.**

**ALL "NEW EQUIPMENT" SHIPPED FOR SALE IN CALIFORNIA WILL HAVE LABELS STATING THAT THE PRODUCT CONTAINS AND/OR PRODUCES PROPOSITION 65 CHEMICALS. ALTHOUGH WE HAVE NOT CHANGED OUR PROCESSES, HAVING THE SAME LABEL ON ALL OUR PRODUCTS FACILITATES MANUFACTURING AND SHIPPING. WE CANNOT ALWAYS KNOW "WHEN, OR IF" PRODUCTS WILL BE SOLD IN THE CALIFORNIA MARKET.**

**YOU MAY RECEIVE INQUIRIES FROM CUSTOMERS ABOUT CHEMICALS FOUND IN, OR PRODUCED BY, SOME OF OUR HEATING AND AIR-CONDITIONING EQUIPMENT, OR FOUND IN NATURAL GAS USED WITH SOME OF OUR PRODUCTS. LISTED BELOW ARE THOSE CHEMICALS AND SUBSTANCES COMMONLY ASSOCIATED WITH SIMILAR EQUIPMENT IN OUR INDUSTRY AND OTHER MANUFACTURERS.**

- GLASS WOOL (FIBERGLASS) INSULATION
- CARBON MONOXIDE (CO)
- FORMALDEHYDE
- BENZENE

**MORE DETAILS ARE AVAILABLE AT THE WEBSITES FOR OSHA (OCCUPATIONAL SAFETY AND HEALTH ADMINISTRATION), AT [WWW.OSHA.GOV](http://WWW.OSHA.GOV) AND THE STATE OF CALIFORNIA'S OEHHA (OFFICE OF ENVIRONMENTAL HEALTH HAZARD ASSESSMENT), AT [WWW.OEHHA.ORG](http://WWW.OEHHA.ORG). CONSUMER EDUCATION IS IMPORTANT SINCE THE CHEMICALS AND SUBSTANCES ON THE LIST ARE FOUND IN OUR DAILY LIVES. MOST CONSUMERS ARE AWARE THAT PRODUCTS PRESENT SAFETY AND HEALTH RISKS, WHEN IMPROPERLY USED, HANDLED AND MAINTAINED.**

## II. INTRODUCTION

This booklet contains the installation and operating instructions for your self-contained air conditioner. There are a few precautions that should be taken to derive maximum satisfaction from it. Improper installation can result in unsatisfactory operation or dangerous conditions.

Read this booklet and any instructions packaged with separate equipment required to make up the system prior to installation. Give this booklet to the owner and explain its provisions. The owner should retain this booklet for future reference.

## III. CHECKING PRODUCT RECEIVED

Upon receiving the unit, inspect it for any damage from shipment. Claims for damage, either shipping or concealed, should be filed immediately with the shipping company. Check the unit model number, electrical characteristics, and accessories to determine if they are correct.

## IV. EQUIPMENT PROTECTION FROM THE ENVIRONMENT

The metal parts of this unit may be subject to rust or deterioration in adverse environmental conditions. This oxidation could shorten the equipment's useful life. Salt spray, fog or mist in seacoast areas, sulphur or chlorine from lawn watering systems, and various chemical contaminants from industries such as paper mills and petroleum refineries are especially corrosive.

**If the unit is to be installed in an area where contaminants are likely to be a problem, special attention should be given to the equipment location and exposure.**

1. Avoid having lawn sprinkler heads spray directly on the unit cabinet.
2. In coastal areas, locate the unit on the side of the building away from the waterfront.
3. Shielding provided by a fence or shrubs may give some protection.
4. Elevating the unit off its slab or base enough to allow air circulation will help avoid holding water against the basepan.

**Regular maintenance will reduce the buildup of contaminants and help to protect the unit's finish.**

## WARNING

**DISCONNECT ALL POWER TO THE UNIT BEFORE STARTING MAINTENANCE. FAILURE TO DO SO CAN RESULT IN SEVERE ELECTRICAL SHOCK OR DEATH.**

1. Frequent washing of the cabinet, fan blade and coil with fresh water will remove most of the salt or other contaminants that build up on the unit.
2. Regular cleaning and waxing of the cabinet with an automobile polish will provide some protection.
3. A liquid cleaner may be used several times a year to remove matter that will not wash off with water.

Several different types of protective coatings are offered in some areas. These coatings may provide some benefit, but the effectiveness of such coating materials cannot be verified by the equipment manufacturer.

**The best protection is frequent cleaning, maintenance and minimal exposure to contaminants.**

## V. SPECIFICATIONS

Suitable for use in mobile homes, manufactured housing, and conventionally constructed residential and commercial buildings where horizontally-ducted systems are preferred.

**FIGURE 1**  
UNIT DIMENSIONS AND ACCESS LOCATIONS

Model	Height "A"
024, 030, 036, 042, 043	29 1/8"
048, 060	37 1/8"

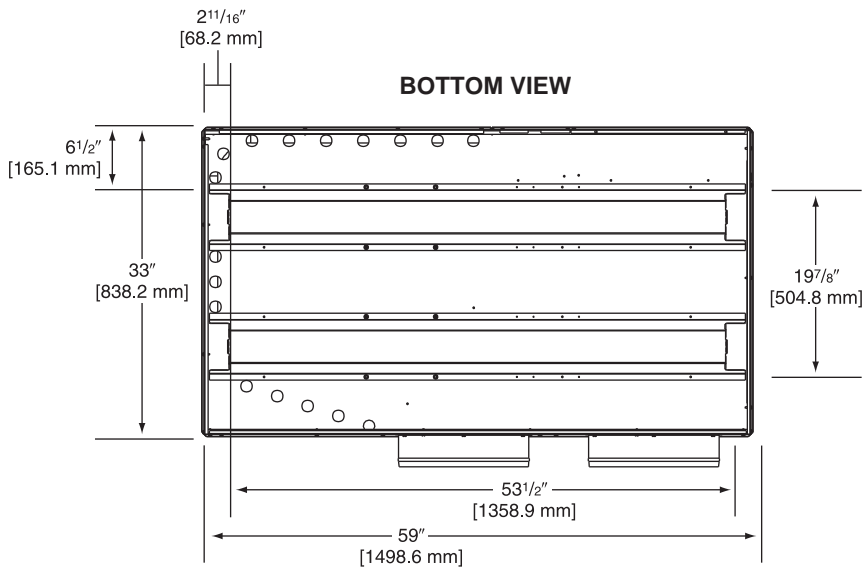
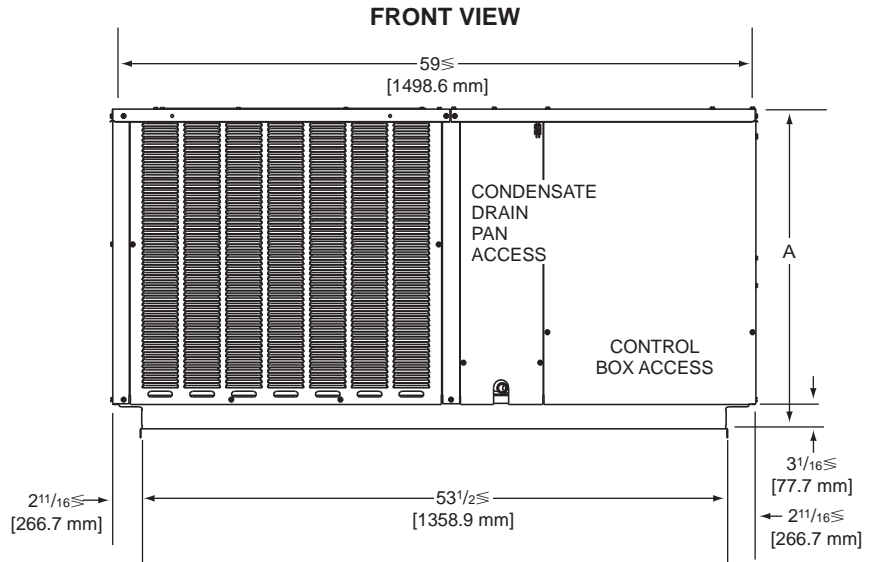

**ELECTRICAL CONNECTIONS**

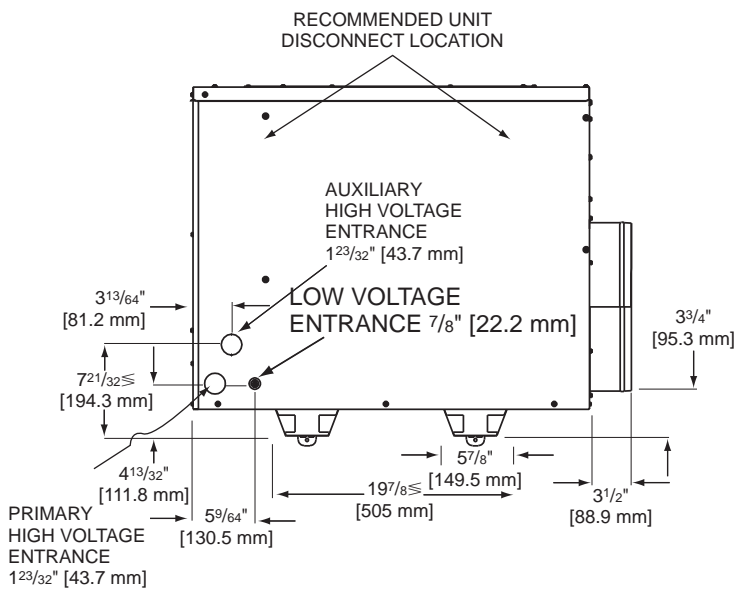

## DUCT CONNECTIONS

### ROUND DUCT CONNECTIONS

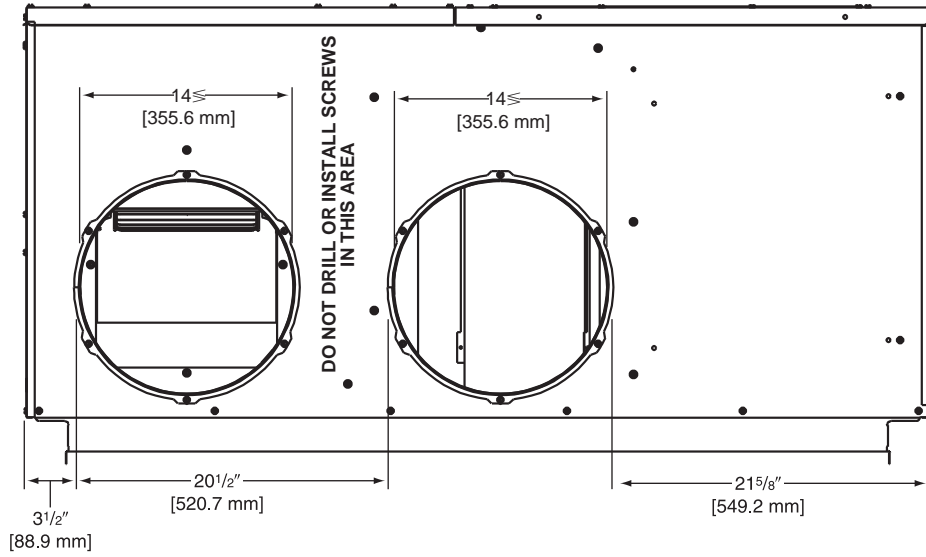

### SQUARE DUCT CONNECTIONS

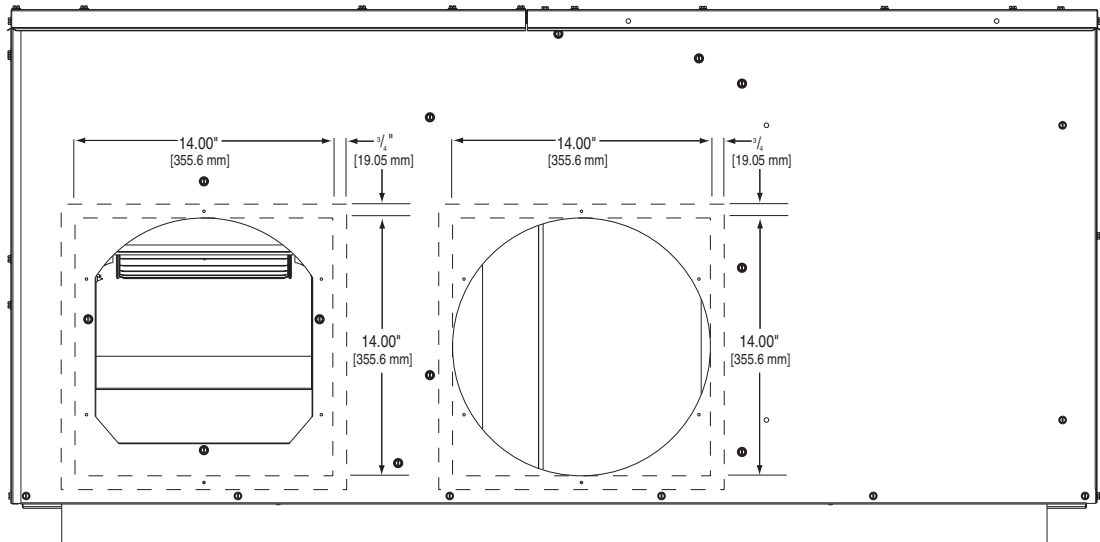

**IMPORTANT: DO NOT SCREW OR DRILL OUTSIDE THE DESIGNATED AREAS.**

**IMPORTANT:** This product is designed to be operated with 14" round supply and return air ducts. Square ducts may be used, provided that a minimum length of 24" of round duct is used on the supply and return connections. This requirement is necessary to maintain blower performance.

## A. GENERAL

The Packaged Air Conditioner is available without heat or with 5, 7, 10, 15, or 20 kW electric heat. Cooling capacities of 2, 2½, 3, 3½, 4 and 5 nominal tons of cooling are available.

The units are weatherized for mounting outside of the building.

The information on the rating plate is in compliance with the FTC and DOE rating for single phase units.

## B. MAJOR COMPONENTS

The unit includes a hermetically-sealed refrigerating system (consisting of a compressor, condenser coil, evaporator coil with refrigerant metering device), a circulation air blower, a condenser fan, and all necessary internal electrical wiring. The cooling system of these units is factory-evacuated, charged and performance tested. Refrigerant amount and type are indicated on rating plate.

## C. R-410A REFRIGERANT

All units are factory charged with R-410A refrigerant.

### 1. Specification of R-410A:

**Application:** *R-410A is not a drop-in replacement for R-22; equipment designs must accommodate its higher pressures. It cannot be retrofitted into R-22 units.*

**Pressure:** *The pressure of R-410A is approximately 60% (1.6 times) greater than R-22. Recovery and recycle equipment, pumps, hoses and the like need to have design pressure ratings appropriate for R-410A. Manifold sets need to range up to 800 psig high-side and 250 psig low-side with a 550 psig low-side retard. Hoses need to have a service pressure rating of 800 psig. Recovery cylinders need to have a 400 psig service pressure rating. DOT 4BA400 or DOT BW400.*

**Combustibility:** At pressures above 1 atmosphere, mixture of R-410A and air can become combustible. *R-410A and air should never be mixed in tanks or supply lines, or be allowed to accumulate in storage tanks. Leak checking should never be done with a mixture of R-410A and air.* Leak checking can be performed safely with nitrogen or a mixture of R-410A and nitrogen.

### 2. Quick Reference Guide For R-410A

- R-410A refrigerant operates at approximately 60% higher pressure (1.6 times) than R-22. Ensure that servicing equipment is designed to operate with R-410A.
- R-410A refrigerant cylinders are pink.
- R-410A, as with other HFC's is only compatible with POE oils.
- Vacuum pumps will not remove moisture from POE oil.
- R-410A systems are to be charged with liquid refrigerants. Prior to March 1999, R-410A refrigerant cylinders had a dip tube. These cylinders should be kept upright for equipment charging. Post March 1999 cylinders do not have a dip tube and should be inverted to ensure liquid charging of the equipment.
- Do not install a suction line filter drier in the liquid line.
- A liquid line filter drier is standard on every unit.
- Desiccant (drying agent) must be compatible for POE oils and R-410A.

### 3. Evaporator Coil / TXV

The thermostatic expansion valve is specifically designed to operate with R-410A. **DO NOT use an R-22 TXV. The existing evaporator must be replaced with the factory specified TXV evaporator specifically designed for R-410A.**

### 4. Tools Required For Installing & Servicing R-410A Models

Manifold Sets:

- Up to 800 PSIG High side
- Up to 250 PSIG Low Side
- 550 PSIG Low Side Retard

Manifold Hoses:

- Service Pressure Rating of 800 PSIG

## WARNING

THE MANUFACTURER'S WARRANTY DOES NOT COVER ANY DAMAGE OR DEFECT TO THE AIR CONDITIONER CAUSED BY THE ATTACHMENT OR USE OF ANY COMPONENTS, ACCESSORIES OR DEVICES (OTHER THAN THOSE AUTHORIZED BY THE MANUFACTURER) INTO, ONTO OR IN CONJUNCTION WITH THE AIR CONDITIONER. YOU SHOULD BE AWARE THAT THE USE OF UNAUTHORIZED COMPONENTS, ACCESSORIES OR DEVICES MAY ADVERSELY AFFECT THE OPERATION OF THE AIR CONDITIONER AND MAY ALSO ENDANGER LIFE AND PROPERTY. THE MANUFACTURER DISCLAIMS ANY RESPONSIBILITY FOR SUCH LOSS OR INJURY RESULTING FROM THE USE OF SUCH UNAUTHORIZED COMPONENTS, ACCESSORIES OR DEVICES.

#### Recovery Cylinders:

- 400 PSIG Pressure Rating
- Dept. of Transportation 4BA400 or BW400

### **▲ CAUTION**

R-410A systems operate at higher pressures than R-22 systems. Do not use R-22 service equipment or components on R-410A equipment.

## **VI. INSTALLATION**

### **A. GENERAL**

#### 1. PRE-INSTALLATION CHECK-POINTS

Before attempting any installation, the following points should be carefully considered:

- Structural strength of supporting members.  
(rooftop installation)
- Clearances and provision for servicing.
- Power supply and wiring.
- Air duct connections.
- Drain facilities and connections.
- Location for minimum noise.

#### 2. LOCATION

These units are designed for outdoor installations. They can be mounted on a slab or rooftop. They are not to be installed within any part of a structure such as an attic, crawl space, closet, or any other place where condenser air flow is restricted or other than outdoor ambient conditions prevail. Since the application of the units is of the outdoor type, it is important to consult your local code authorities at the time the first installation is made.

### **B. OUTSIDE SLAB INSTALLATION**

**(Typical outdoor slab installations are shown in Figure 2.)**

- Select a location where external water drainage cannot collect around the unit.
- Provide a level concrete slab extending 3" beyond all four sides of the unit. The slab should be sufficient above grade to prevent ground water from entering the unit.

**IMPORTANT:** To prevent transmission of noise or vibration, slab should not be connected to building structure.

- The location of the unit should be such as to provide proper access for inspection and servicing.
- Locate unit where operating sounds will not disturb owner or neighbors.
- Locate unit so roof runoff water does not pour directly on the unit. Provide gutter or other shielding at roof level. Do not locate unit in an area where excessive snow drifting may occur or accumulate.

### **C. CLEARANCES**

The following minimum clearances must be observed for proper unit performance and serviceability.

- Provide 30" minimum clearance at the front and 18" on the right side of the unit for service access. Provide 12" minimum clearance on the left side of the unit for air inlet.
- Provide 60" minimum clearance from top of unit.
- Unit is design certified for application on combustible flooring with 0" minimum clearance.
- See Figure 2 for illustration of minimum installation-service clearances.

### **D. ROOFTOP INSTALLATION**

- Before locating the unit on the roof, make sure that the strength of the roof and beams is adequate at that point to support the weight involved. (See specification sheet for weight of unit.) This is very important and user's responsibility.
- The unit should be placed on a solid and level platform of adequate strength.



**FIGURE 2**  
**PACKAGE AIR CONDITIONER**  
 OUTSIDE SLAB INSTALLATION, BASEMENT OR  
 CRAWL SPACE DISTRIBUTING SYSTEM

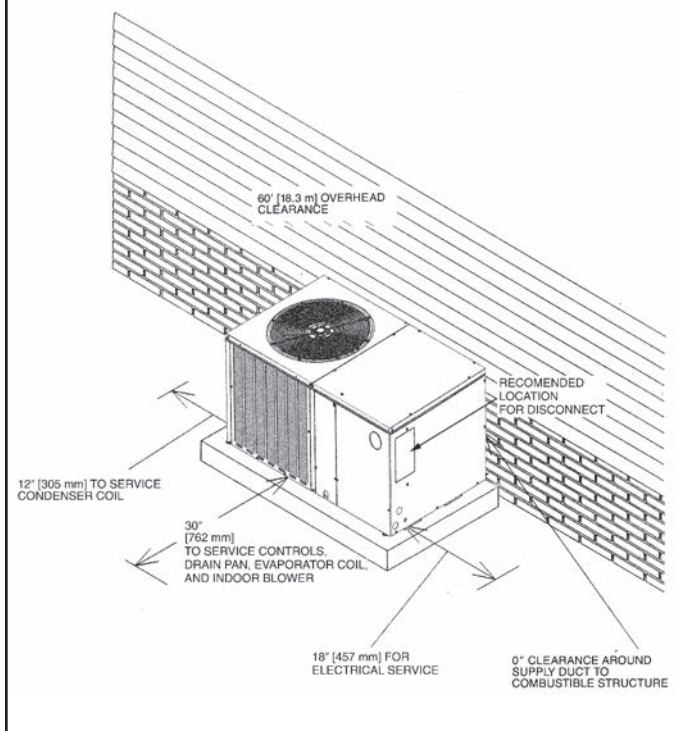

**FIGURE 3**  
**PACKAGE AIR CONDITIONER**  
 PITCHED ROOFTOP INSTALLATION, ATTIC  
 OR DROP CEILING DISTRIBUTING SYSTEM.  
 MUST BE MOUNTED LEVEL.

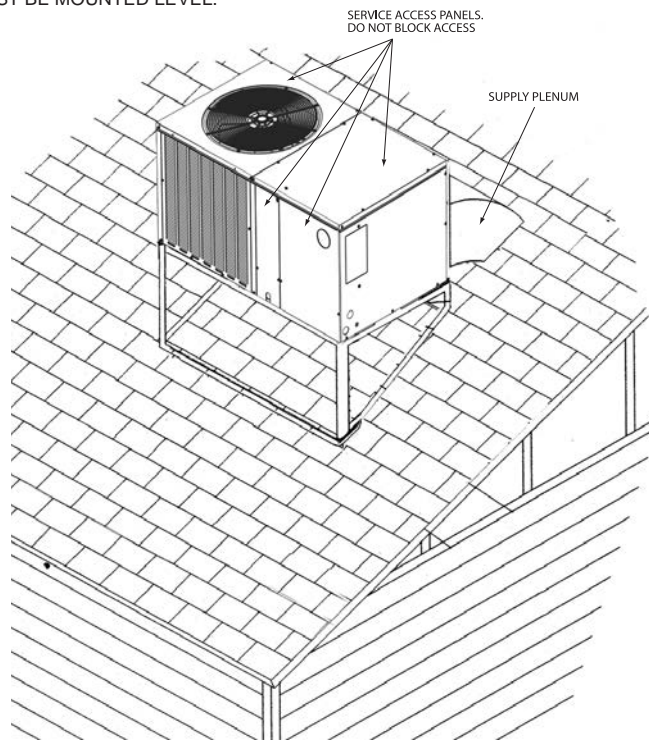

3. The location of the unit on the roof should be such as to provide proper access for inspection and servicing (Figure 3).

**IMPORTANT:** *If unit will not be put into service immediately, cover supply and return openings to prevent excessive condensation.*

## VII. DUCTWORK

Ductwork should be fabricated by the installing contractor in accordance with local codes and NFPA90A. Industry manuals may be used as a guide when sizing and designing the duct system - contact Air Conditioning Contractors of America, 1513 16th St. N.W., Washington, D.C. 20036.

### **⚠ WARNING**

**DO NOT, UNDER ANY CIRCUMSTANCES, CONNECT RETURN DUCTWORK TO ANY OTHER HEAT PRODUCING DEVICE SUCH AS A FIREPLACE INSERT, STOVE, ETC. UNAUTHORIZED USE OF SUCH DEVICES MAY RESULT IN FIRE, CARBON MONOXIDE POISONING, EXPLOSION, PROPERTY DAMAGE, SEVERE PERSONAL INJURY OR DEATH.**

Place the unit as close to the space to be air conditioned as possible allowing clearance dimensions as indicated. Run ducts as directly as possible to supply and return outlets. Use of non-flammable waterproof flexible connectors on both supply and return connections at the unit to reduce noise transmission is recommended.

It is preferable to install the unit on the roof of the structure if the registers or diffusers are located on the wall or in the ceiling. Consider a slab installation when the registers are low on a wall or in the floor.

On ductwork exposed to outside air conditions of temperature and humidity, use a minimum of 2" of insulation and a vapor barrier. Distribution system in attic, furred space or crawl space should be insulated with at least 2" of insulation with vapor barrier. One-half to 1" thickness of insulation is usually sufficient for ductwork inside the air conditioned space.

Provide balancing dampers for each branch duct in the supply system. Properly support the ductwork from the structure.

## VIII. FILTERS

Filters are not provided with this unit. They must be supplied and installed in the return air duct by the installer. A field installed filter grille is recommended for easy and convenient access to the filters for periodic inspection and cleaning. Filters must have adequate face area for the rated air quantity of the unit. See General Database for recommended filter size.

## IX. CONDENSATE DRAIN

The indoor coil condensate drain ends with a PVC stub. A trap is provided in for proper condensate drainage and to prevent debris from being drawn into the unit. Do not connect drain to closed sewer line. It is not recommended that a PVC cement or other permanent installation be used so that the drain line and/or drain pan can be easily cleaned in the future. The drain trap is located in the control box during shipping. To install, slide clear plastic tube over drain pan connection. The white PVC trap can be oriented as required by installation.

**FIGURE 4**

*REMOVABLE CONDENSATE DRAIN PAN AND REMOVAL PROCEDURE*

A small side panel grants access to a removable, sloped drain pan (A), which helps to ensure indoor air quality (IAQ) throughout the life of the unit. A drain trap (B) assembly is provided for convenience.



## X. ELECTRICAL WIRING

Field wiring must comply with the National Electrical Code\* and applicable local codes.

\*C.E.C. in Canada

### A. POWER WIRING

1. It is important that proper electrical power is available at the unit. Voltage should not vary more than 10% from that stamped on the unit rating plate. On three phase units, phases must be balanced within 3%.
2. Install a branch circuit disconnect within sight of the unit and of adequate size to handle the starting current. (See Heater Kit Tables.)
3. For branch circuit wiring (main power supply to unit disconnect), the minimum wire size can be determined from the National Electrical Code or Canadian Electrical Code or nameplate or from Heater Kit Tables.
4. This unit supports both single and dual point electrical connection for unit and electric heat accessory.
5. Power wiring must be run in grounded rain-tight conduit.

## WARNING

TURN OFF ELECTRIC POWER AT THE FUSE BOX OR SERVICE PANEL BEFORE MAKING ANY ELECTRICAL CONNECTIONS.

ALSO, THE GROUND CONNECTION MUST BE COMPLETED BEFORE MAKING LINE VOLTAGE CONNECTIONS. FAILURE TO DO SO CAN RESULT IN ELECTRICAL SHOCK, SEVERE PERSONAL INJURY OR DEATH.

## B. POWER WIRING AND ELECTRIC HEATER KIT INSTRUCTIONS

1. Turn off power to unit.
2. Remove control box access panel.
3. Remove unit indoor section top cover.
4. Remove wire notch cover from control bulkhead and discard. Retain screw.
5. Remove heater element cover plate from blower outlet opening and discard. Retain screws.
6. Mount heater fuse block assembly in location indicated with the three included screws.
7. Route wire harness assembly through wire notch in control bulkhead and mount element assembly in blower outlet opening with screws previously retained.
8. Center wire routing plate over notch in blower bulkhead and secure with screw previously retained.
9. Route and tie wiring as shown in Figure 5. Wiring must not contact moving parts or uninsulated electrical connections.
10. Replace unit indoor top cover.
11. Connect power and control wiring as indicated below:
  - a. **Single-point wiring:** Connect high voltage field power leads to heater kit fuse block and connect included unit power pigtailed from heater kit fuse block to unit contactor L1 and L3 connections. Connect ground lead to ground lug on heater kit fuse block.
  - b. **Dual-circuit wiring:** Remove unit power pigtailed from heater kit fuse block and discard. Connect one set of high voltage field power circuit leads to the heater kit fuse block and connect ground lead to ground lug on heater kit fuse block.  
Connect the second set of high voltage field power leads to L1 and L3 on the unit contactor. Connect ground lead to ground lug on control box bulkhead.
  - c. Connect heater kit control plug to receptacle in control box.
12. Replace control box access panel.
13. Restore power to unit and verify proper unit and heater kit operation.

## C. CONTROL WIRING (Class II)

1. Do not run low voltage wiring in conduit with power wiring.
2. Control wiring is routed through the 7/8" hole corner adjacent to the control box. See Electrical Connections, Figure 1. Use a minimum #18 AWG thermostat wire. For wire lengths exceeding 50', use #16 AWG thermostat wire. The low voltage wires are connected to the unit pigtailed which are supplied with the unit in the low voltage connection box located within the unit control box. See Figure 5.
3. Figure 6 shows representative low voltage connection diagrams. Read your thermostat installation instructions for any special requirements for your specific thermostat.

**NOTE** — Units installed in Canada require that an outdoor thermostat (30,000 min. cycles of endurance) be installed and be wired with C.E.C. Class I wiring.

**FIGURE 5**  
HEATER KIT INSTALLATION

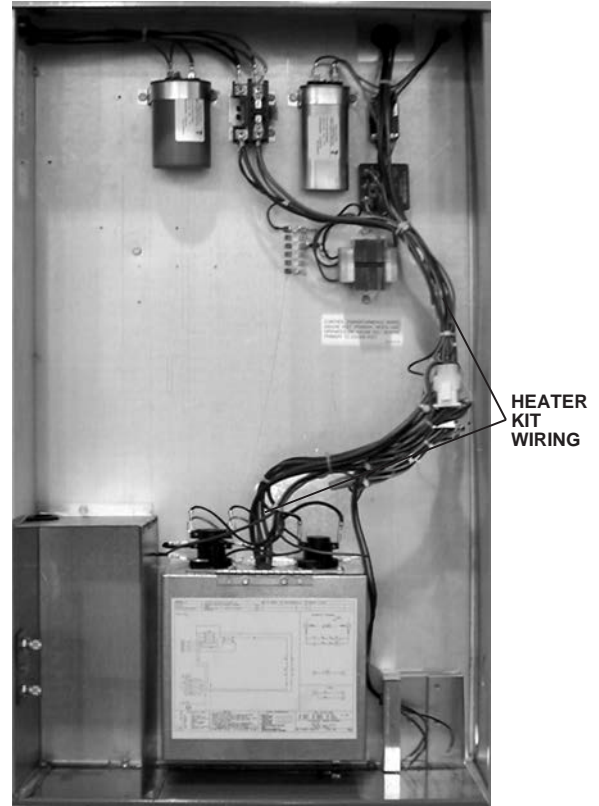

#### **D. INTERNAL WIRING**

1. A diagram of the internal wiring of this unit is located on the electrical control box cover. If any of the original wire as supplied with the appliance must be replaced, the wire gauge and insulation must be the same as original wiring.

#### **E. GROUNDING**

##### **⚠ WARNING**

**THE UNIT MUST BE PERMANENTLY GROUNDED. A GROUNDING LUG IS PROVIDED. FAILURE TO GROUND THIS UNIT CAN RESULT IN FIRE OR ELECTRICAL SHOCK CAUSING PROPERTY DAMAGE, SEVERE PERSONAL INJURY OR DEATH.**

#### **F. THERMOSTAT**

Mount the thermostat on an inside wall about five feet above the floor in a location where it will not be affected by unconditioned air, sun, or drafts from open doors or other sources. READ installation instructions in air conditioner thermostat package CAREFULLY because each has some different wiring requirements.

## **XI. INDOOR AIR FLOW DATA**

All 208/230 volt units are equipped with multi-speed indoor blower motors. Each unit is shipped factory wired for the proper speed at a normal external static. See Airflow Performance Table for blower performance.

## INDOOR AIRFLOW PERFORMANCE - RSNM - 230 VOLTS

Nominal Cooling Capacity Tons	Motor Speed From Factory	Manufacturer Recommended Air-Flow Range (Min / Max) CFM	Blower Size/ Motor HP & # of Speeds	Motor Speed	CFM Air Delivery/RPM/Watts-230 Volts										
					External Static Pressure-Inches W.C.										
					0.10	0.20	0.30	0.40	0.50	0.60	0.70	0.80	0.90	1.00	
2.0	Low	700 / 900	10x9 1/4 2 Speed (PSC Motor)	Low	CFM	827	811	782	740	684	614	531	435	—	—
					RPM	450	533	626	742	799	894	932	985	—	—
					Watts	278	273	269	254	244	227	216	198	—	—
2.5	Low	875 / 1125	10x9 1/3 2 Speed (PSC Motor)	Low	CFM	1230	1223	1216	1211	1187	1125	1020	874	696	504
					RPM	575	643	703	767	819	877	976	1001	1072	1092
					Watts	479	468	455	448	431	416	357	341	279	259
2.5	Low	875 / 1125	10x9 1/3 2 Speed (PSC Motor)	High	CFM	1032	1030	1014	979	923	843	735	596	423	—
					RPM	533	570	659	746	795	863	934	1019	1050	—
					Watts	336	331	326	314	303	280	271	227	210	—
3.0	Low	1050 / 1350	10x9 1/2 2 Speed (PSC Motor)	High	CFM	1312	1301	1292	1276	1246	1196	1117	1003	845	—
					RPM	592	646	712	768	824	883	933	1012	1035	—
					Watts	482	473	466	454	433	421	401	349	329	—
3.0	Low	1050 / 1350	10x9 1/2 2 Speed (PSC Motor)	Low	CFM	1261	1253	1225	1177	1110	1023	915	788	641	—
					RPM	648	705	754	802	854	896	985	1008	1041	—
					Watts	398	395	387	391	370	361	323	310	300	—
3.5	Low	1225 / 1575	11x9 1/2 2 Speed (PSC Motor)	High	CFM	2068	2008	1957	1905	1841	1753	1629	1458	1228	929
					RPM	850	883	917	946	972	999	1028	1049	1091	1108
					Watts	826	806	784	762	734	702	658	626	546	512
3.5	Low	1225 / 1575	11x9 1/2 2 Speed (PSC Motor)	Low	CFM	1431	1394	1348	1302	1258	1208	1140	1030	849	557
					RPM	540	579	633	686	724	776	831	868	1035	1076
					Watts	482	479	477	470	459	453	437	423	335	292
3.5	Low	1225 / 1575	11x9 1/2 2 Speed (PSC Motor)	High	CFM	1960	1936	1903	1859	1806	1742	1669	1585	1491	1387
					RPM	703	727	750	780	809	846	877	910	940	975
					Watts	783	782	776	759	750	729	712	686	656	625
4.0	Low	1400 / 1800	11x9 3/4 2 Speed (PSC Motor)	Low	CFM	1674	1638	1595	1547	1492	1432	1365	1293	1214	1129.1
					RPM	576	618	668	708	753	789	832	874	915	954
					Watts	575	563	556	549	544	532	522	503	483	465
4.0	Low	1400 / 1800	11x9 3/4 2 Speed (PSC Motor)	High	CFM	1996	1976	1947	1909	1863	1808	1744	1671	1590	1500
					RPM	680	722	752	781	807	833	867	912	936	973
					Watts	799	787	784	760	753	749	730	699	693	652
5.0	Low	1750 / 2250	11x9 3/4 2 Speed (PSC Motor)	Low	CFM	2044	2017	1983	1941	1892	1836	1773	1702	1623	1537
					RPM	689	723	756	798	822	855	889	924	951	988
					Watts	886	870	865	849	831	817	799	782	755	726
5.0	Low	1750 / 2250	11x9 3/4 2 Speed (PSC Motor)	High	CFM	2693	2654	2606	2549	2483	2408	2323	2230	2127	2015
					RPM	876	897	915	938	956	975	996	1009	1025	1044
					Watts	1438	1427	1399	1368	1340	1312	1274	1228	1192	1146

# INDOOR AIRFLOW PERFORMANCE - RSNM - 208 VOLTS

Nominal Cooling Capacity Tons	Motor Speed From Factory	Manufacturer Recommended Air-Flow Range (Min / Max) CFM	Blower Size/ Motor HP & # of Speeds	Motor Speed	CFM Air Delivery/RPM/Watts-208 Volts									
					External Static Pressure-Inches W.C.									
					0.10	0.20	0.30	0.40	0.50	0.60	0.70	0.80	0.90	
2.0	Low	700 / 900	10x9 1/4 2 Speed (PSC Motor)	Low	CFM	723	692	654	609	556	496	428	—	—
					RPM	443	528	651	710	819	863	914	—	—
					Watts	230	222	219	214	202	196	184	—	—
2.5	Low	875 / 1125	10x9 1/3 2 Speed (PSC Motor)	High	CFM	1062	1062	1058	1043	1013	962	884	774	627
					RPM	528	618	674	735	812	895	936	985	1055
					Watts	396	393	384	376	361	335	318	297	244
2.5	Low	875 / 1125	10x9 1/3 2 Speed (PSC Motor)	Low	CFM	923	904	874	832	774	698	602	483	—
					RPM	498	543	648	728	806	853	947	989	—
					Watts	280	278	268	259	252	243	219	201	—
3.0	Low	1050 / 1350	10x9 1/2 2 Speed (PSC Motor)	High	CFM	1164	1154	1143	1124	1090	1034	948	826	660
					RPM	526	596	670	744	803	864	945	971	1051
					Watts	401	398	388	379	371	350	322	310	259
3.0	Low	1050 / 1350	10x9 1/2 2 Speed (PSC Motor)	Low	CFM	1145	1142	1118	1073	1006	918	—	—	—
					RPM	556	645	703	769	828	909	—	—	—
					Watts	346	340	335	326	321	298	—	—	—
3.5	Low	1225 / 1575	11x9 1/2 2 Speed (PSC Motor)	High	CFM	1884	1850	1815	1772	1712	1630	1516	1363	1164
					RPM	791	834	871	912	946	975	1004	1032	1083
					Watts	704	694	675	655	638	606	581	548	464
3.5	Low	1225 / 1575	11x9 1/2 2 Speed (PSC Motor)	Low	CFM	1279	1237	1196	1151	1098	1032	950	846	717.13
					RPM	490	539	598	653	709	772	811	887	928
					Watts	401	400	393	391	381	373	364	343	329
4.0	Low	1400 / 1800	11x9 3/4 2 Speed (PSC Motor)	High	CFM	1751	1729	1698	1658	1608	1549	1481	1404	1317
					RPM	640	668	706	734	781	813	851	888	937
					Watts	660	658	651	644	628	617	603	581	557
4.0	Low	1400 / 1800	11x9 3/4 2 Speed (PSC Motor)	Low	CFM	1400	1393	1373	1337	1288	1225	1147	1055	949
					RPM	536	578	623	677	718	782	830	863	902
					Watts	471	466	458	455	453	442	429	420	403
5.0	Low	1750 / 2250	11x9 3/4 2 Speed (PSC Motor)	High	CFM	1786	1764	1734	1695	1649	1595	1532	1462	1384
					RPM	618	643	684	726	757	805	841	883	924
					Watts	665	660	651	646	638	626	612	596	573
5.0	Low	1750 / 2250	11x9 3/4 2 Speed (PSC Motor)	Low	CFM	1848	1821	1785	1742	1690	1630	1562	1486	1402
					RPM	660	685	722	755	795	836	867	904	940
					Watts	731	725	720	707	698	680	665	651	623
5.0	Low	1750 / 2250	11x9 3/4 2 Speed (PSC Motor)	High	CFM	2444	2420	2384	2337	2278	2208	2127	2034	1930
					RPM	829	838	863	885	914	936	958	983	1003
					Watts	1225	1218	1197	1191	1160	1135	1105	1068	1035

## INDOOR AIRFLOW PERFORMANCE - RSPM - 230 VOLTS

Nominal Cooling Capacity Tons	Motor Speed From Factory	Manufacturer Recommended Air-Flow Range (Min / Max) CFM	Blower Size/ Motor HP & # of Speeds	Motor Speed	CFM Air Delivery/RPM/Watts-230 Volts												
					External Static Pressure-Inches W.C.												
					0.10	0.20	0.30	0.40	0.50	0.60	0.70	0.80	0.90	1.00			
2.0	Low (Tap 2)	700 / 900	10x9 1/4 2 Speed (X-13 Motor)	Low (Tap 2)	CFM	939	877	816	754	693	631	570	508	447	-		
				RPM	585	601	655	744	809	860	915	1001	1043	-			
				Watts	131	116	97	110	121	126	136	149	152	-			
2.5	Low (Tap 2)	875 / 1125	10x9 1/3 2 Speed (X-13 Motor)	High (Tap 1)	CFM	1240	1184	1127	1071	1014	958	901	845	788	732		
				RPM	607	634	698	761	815	880	946	989	1038	1091			
				Watts	161	145	159	173	182	196	210	220	231	237			
2.5	Low (Tap 2)	875 / 1125	10x9 1/3 2 Speed (X-13 Motor)	Low (Tap 2)	CFM	1169	1109	1049	988	928	868	807	747	687	626		
				RPM	603	619	693	756	809	893	942	989	1034	1076			
				Watts	144	130	138	151	159	174	185	195	199	209			
3.0	Low (Tap 2)	1050 / 1350	10x9 1/2 2 Speed (X-13 Motor)	High (Tap 1)	CFM	1365	1316	1266	1217	1168	1119	1069	1020	971	922		
				RPM	631	677	732	784	843	894	942	1035	1077	1118			
				Watts	177	190	204	218	234	247	256	279	289	294			
3.0	Low (Tap 2)	1050 / 1350	10x9 1/2 2 Speed (X-13 Motor)	Low (Tap 2)	CFM	1328	1280	1231	1183	1135	1086	1038	990	941	893		
				RPM	648	697	752	807	857	903	989	1036	1077	1114			
				Watts	178	191	206	220	233	246	265	277	286	291			
3.5	Low (Tap 2)	1225 / 1575	11x9 1/2 2 Speed (X-13 Motor)	High (Tap 1)	CFM	1510	1464	1418	1373	1327	1281	1235	1190	1144	1098		
				RPM	707	743	792	841	890	942	981	1031	1114	1151			
				Watts	248	261	277	292	307	322	334	348	366	358			
3.5	Low (Tap 2)	1225 / 1575	11x9 1/2 2 Speed (X-13 Motor)	Low (Tap 2)	CFM	1542	1490	1438	1386	1335	1283	1231	1180	1128	1076		
				RPM	598	617	662	714	758	800	849	876	913	951			
				Watts	244	231	237	254	270	285	304	313	326	340			
3.5	Low (Tap 2)	1225 / 1575	11x9 1/2 2 Speed (X-13 Motor)	High (Tap 1)	CFM	1740	1695	1649	1604	1558	1513	1467	1422	1376	1331		
				RPM	632	665	709	749	797	833	879	917	951	981			
				Watts	295	311	331	350	371	386	409	426	440	454			
4.0	Low (Tap 2)	1400 / 1800	11x9 3/4 2 Speed (X-13 Motor)	Low (Tap 2)	CFM	1701	1655	1609	1563	1517	1471	1425	1379	1333	1287		
				RPM	624	648	696	743	787	826	863	895	934	970			
				Watts	280	287	309	328	347	363	380	392	410	426			
4.0	Low (Tap 2)	1400 / 1800	11x9 3/4 2 Speed (X-13 Motor)	High (Tap 1)	CFM	1921	1878	1835	1792	1749	1706	1663	1620	1577	1534		
				RPM	678	706	738	776	816	865	899	932	967	994			
				Watts	385	400	416	439	458	484	501	517	537	550			
5.0	Low (Tap 2)	1750 / 2250	11x9 3/4 2 Speed (X-13 Motor)	Low (Tap 2)	CFM	1986	1945	1905	1864	1823	1782	1741	1700	1659	1618		
				RPM	731	759	792	832	871	909	943	979	1014	1055			
				Watts	446	458	477	499	521	543	562	582	600	621			
5.0	Low (Tap 2)	1750 / 2250	11x9 3/4 2 Speed (X-13 Motor)	High (Tap 1)	CFM	2229	2190	2152	2114	2075	2037	1999	1960	1922	1884		
				RPM	795	824	861	882	919	952	983	1013	1045	1077			

# INDOOR AIRFLOW PERFORMANCE - RSPM - 208 VOLTS

Nominal Cooling Capacity Tons	Motor Speed From Factory	Manufacturer Recommended Air-Flow Range (Min / Max) CFM	Blower Size/ Motor HP & # of Speeds	Motor Speed	CFM Air Delivery/RPM/Watts-208 Volts										
					External Static Pressure-Inches W.C.										
					0.10	0.20	0.30	0.40	0.50	0.60	0.70	0.80	0.90	1.00	
2.0	Low (Tap 2)	700 / 900	10x9 1/4 2 Speed (X-13 Motor)	Low	CFM	959	892	825	758	691	624	557	491	—	
				(Tap 2)	RPM	582	606	655	723	808	851	906	996	—	
				Watts	132	110	96	106	119	123	132	144	—		
2.5	Low (Tap 2)	875 / 1125	10x9 1/3 2 Speed (X-13 Motor)	High	CFM	1229	1170	1112	1054	996	938	879	821	763	
				(Tap 1)	RPM	607	634	698	761	815	880	946	989	1038	
				Watts	161	145	159	173	182	196	210	220	231		
2.5	Low (Tap 2)	875 / 1125	10x9 1/3 2 Speed (X-13 Motor)	Low	CFM	1162	1099	1035	972	908	844	781	717	654	
				(Tap 2)	RPM	603	626	690	752	815	906	941	984	1027	
				Watts	143	124	136	148	157	175	180	188	192		
3.0	Low (Tap 2)	1050 / 1350	11x9 1/2 2 Speed (X-13 Motor)	High	CFM	1306	1253	1200	1147	1095	1042	989	937	884	
				(Tap 1)	RPM	632	679	733	787	841	883	941	1035	1067	
				Watts	174	187	201	215	227	235	248	266	273		
3.0	Low (Tap 2)	1050 / 1350	11x9 1/2 2 Speed (X-13 Motor)	Low	CFM	1328	1276	1223	1171	1118	1066	1013	961	—	
				(Tap 2)	RPM	642	693	747	803	852	903	988	1031	—	
				Watts	173	187	200	214	226	238	254	263	—		
3.5	Low (Tap 2)	1225 / 1575	11x9 1/2 2 Speed (X-13 Motor)	High	CFM	1508	1459	1409	1359	1310	1260	1210	1160	1111	
				(Tap 1)	RPM	698	738	789	839	888	933	983	1035	1103	
				Watts	243	255	271	285	299	310	322	332	343		
3.5	Low (Tap 2)	1225 / 1575	11x9 1/2 2 Speed (X-13 Motor)	Low	CFM	1531	1477	1423	1370	1316	1262	1208	1154	1101	
				(Tap 2)	RPM	602	619	668	715	757	801	844	878	918	
				Watts	238	227	236	251	266	281	296	307	320		
4.0	Low (Tap 2)	1400 / 1800	11x9 3/4 2 Speed (X-13 Motor)	High	CFM	1724	1678	1632	1586	1540	1495	1449	1403	1357	
				(Tap 1)	RPM	639	671	715	759	794	834	875	911	948	
				Watts	295	309	330	348	363	380	397	414	429		
4.0	Low (Tap 2)	1400 / 1800	11x9 3/4 2 Speed (X-13 Motor)	Low	CFM	1708	1658	1609	1559	1510	1460	1410	1361	1311	
				(Tap 2)	RPM	619	651	686	741	783	822	859	894	937	
				Watts	280	284	298	323	339	355	370	385	402		
5.0	Low (Tap 2)	1750 / 2250	11x9 3/4 2 Speed (X-13 Motor)	High	CFM	1917	1872	1827	1782	1736	1691	1646	1601	1556	
				(Tap 1)	RPM	673	702	736	769	818	860	898	928	960	
				Watts	377	392	409	426	451	473	490	504	518		
5.0	Low (Tap 2)	1750 / 2250	11x9 3/4 2 Speed (X-13 Motor)	Low	CFM	1954	1914	1874	1833	1793	1753	1713	1673	1632	
				(Tap 2)	RPM	719	747	779	818	857	894	928	963	998	
				Watts	439	451	469	491	512	534	553	573	590		
5.0	Low (Tap 2)	1750 / 2250	11x9 3/4 2 Speed (X-13 Motor)	High	CFM	2173	2136	2098	2061	2024	1986	1949	1911	1874	
				(Tap 1)	RPM	775	803	830	860	896	928	959	988	1019	



**FIGURE 6**

VOLTAGE CONNECTIONS DIAGRAMS – STANDARD CONTROL WIRING

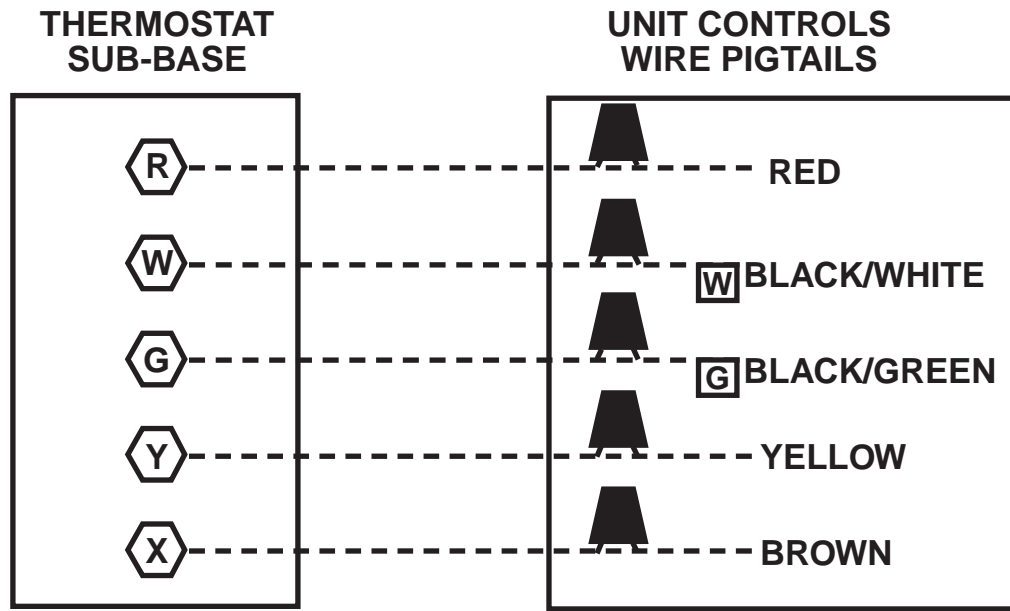

## XII. PRE-START CHECK

1. Is unit properly located and level?
2. Is ductwork insulated, weatherproofed, with proper spacing to combustible materials?
3. Is air free to travel to and from outdoor coil? (See Figure 1.)
4. Is the wiring correct, tight, and according to unit wiring diagram?
5. Is unit grounded?
6. Are field supplied air filters in place and clean?
7. Do the outdoor fan and indoor blower turn freely without rubbing, and are they tight on the motor shafts?

## XIII. STARTUP

1. Turn thermostat to "OFF," turn "on" power supply at disconnect switch.
2. Turn temperature setting as high as it will go.
3. Turn fan switch to "ON."
4. Indoor blower should run. Be sure it is running in the right direction.
5. Turn fan switch to "AUTO." Turn system switch to "COOL" and turn temperature setting below room temperature. Unit should run in cooling mode.
6. Is outdoor fan operating correctly in the right direction?
7. Is compressor running correctly.
8. Turn thermostat system switch to "HEAT." Unit should stop. Wait 5 minutes, then raise temperature setting to above room temperature. After about 30 to 50 seconds auxiliary heaters, if installed, should come on.
9. Check the refrigerant charge using the instructions located on control box cover. Replace service port caps. Service port cores are for system access only and will leak if not tightly capped.
- 10 Turn thermostat system switch to proper mode "HEAT" or "COOL" and set thermostat to proper temperature setting. Record the following after the unit has run some time.
  - A. Operating Mode \_\_\_\_\_
  - B. Discharge Pressure (High) \_\_\_\_\_ PSIG
  - C. Vapor Pressure at Compressor (Low) \_\_\_\_\_ PSIG
  - D. Vapor Line Temperature at Compressor \_\_\_\_\_ °F.
  - E. Indoor Dry Bulb \_\_\_\_\_ °F.
  - F. Indoor Wet Bulb \_\_\_\_\_ °F.
  - G. Outdoor Dry Bulb \_\_\_\_\_ °F.
  - H. Outdoor Wet Bulb \_\_\_\_\_ °F.
  - I. Voltage at Contactor \_\_\_\_\_ Volts

J. Current at Contactor \_\_\_\_\_ Amps  
K. Model Number \_\_\_\_\_  
L. Serial Number \_\_\_\_\_  
M. Location \_\_\_\_\_  
N. Owner \_\_\_\_\_  
O. Date \_\_\_\_\_

11. Adjust discharge air grilles and balance system.
12. Check ducts for condensation and air leaks.
13. Check unit for tubing and sheet metal rattles.
14. Instruct the owner on operation and maintenance.
15. Leave "USE AND CARE" instructions with owner.

---

## XIV. OPERATION

Most single phase units are not equipped with start relay or start capacitor. It is important that such systems be off for a minimum of 5 minutes before restarting to allow equalization of pressures. Do not move the thermostat to cycle unit without waiting five minutes. To do so may cause the compressor to stop on an automatic open overload device or blow a fuse. Poor electrical service can cause nuisance tripping in overloads or blow fuses.

**IMPORTANT:** *The compressor has an internal overload protector. Under some conditions, it can take up to 2 hours for this overload to reset. Make sure overload has had time to reset before condemning the compressor.*

These units are equipped with a time delay control (TDC1). The control allows the blower to operate for 45 to 90 seconds after the thermostat is satisfied.

### A. CONTROL SYSTEM OPERATION

1. In the cooling mode, the thermostat will, on a call for cooling, energize the compressor contactor and the indoor blower relay. The indoor blower can be operated continuously by setting the thermostat fan switch at the "ON" position.
2. In the heating mode, the first heat stage of the thermostat will energize one or more supplementary resistance heaters. If required or considered desirable, the resistance heat may also be controlled by outdoor thermostats. In the heating mode, the thermostat will, on a call for heating, energize the indoor blower relay.

# XV. GENERAL DATA - RSNM

## NOMINAL SIZES 2-5 TONS [7-17.6 kW]

Model RSNM- Series	A024JK	A030JK	A036CK	A036JK
<b>Cooling Performance<sup>1</sup></b>				Continued ->
Gross Cooling Capacity Btu [kW]	24,800 [7.27]	30,000 [8.79]	37,200 [10.9]	37,200 [10.9]
EER/SEER <sup>2</sup>	11.3/13	11.5/13	11.3/13	11.3/13
Nominal CFM/ARI Rated CFM [L/s]	800/800 [378/378]	1000/1000 [472/472]	1200/1200 [566/566]	1200/1200 [566/566]
ARI Net Cooling Capacity Btu [kW]	23,800 [6.97]	28,800 [8.44]	35,800 [10.49]	35,800 [10.49]
Net Sensible Capacity Btu [kW]	18,400 [5.39]	22,200 [6.5]	27,300 [8]	27,300 [8]
Net Latent Capacity Btu [kW]	5,400 [1.58]	6,600 [1.93]	8,500 [2.49]	8,500 [2.49]
Net System Power kW	2.1	2.5	3.17	3.17
<b>Compressor</b>				
No./Type	1/Copeland Scroll	1/Copeland Scroll	1/Copeland Scroll	1/Copeland Scroll
<b>Outdoor Sound Rating (dB)<sup>3</sup></b>	76	76	76	76
<b>Outdoor Coil - Fin Type</b>	Louvered	Louvered	Louvered	Louvered
Tube Type	Rifled	Rifled	Rifled	Rifled
Tube Size in. [mm] OD	0.375 [9.5]	0.375 [9.5]	0.375 [9.5]	0.375 [9.5]
Face Area sq. ft. [sq. m]	10.44 [0.97]	12.64 [1.17]	12.65 [1.18]	12.65 [1.18]
Rows / FPI [FPcm]	1 / 20 [8]	1 / 22 [9]	1 / 22 [9]	1 / 22 [9]
<b>Indoor Coil - Fin Type</b>	Louvered	Louvered	Louvered	Louvered
Tube Type	Rifled	Rifled	Rifled	Rifled
Tube Size in. [mm]	0.375 [9.5]	0.375 [9.5]	0.375 [9.5]	0.375 [9.5]
Face Area sq. ft. [sq. m]	4.33 [0.4]	4.33 [0.4]	4.33 [0.4]	4.33 [0.4]
Rows / FPI [FPcm]	2 / 15 [6]	2 / 15 [6]	2 / 15 [6]	2 / 15 [6]
Refrigerant Control	TX Valves	TX Valves	TX Valves	TX Valves
Drain Connection No./Size in. [mm] <sup>4</sup>	1/1 [25.4]	1/1 [25.4]	1/1 [25.4]	1/1 [25.4]
<b>Outdoor Fan - Type</b>	Propeller	Propeller	Propeller	Propeller
No. Used/Diameter in. [mm]	1/24 [609.6]	1/24 [609.6]	1/24 [609.6]	1/24 [609.6]
Drive Type/No. Speeds	Direct/1	Direct/1	Direct/1	Direct/1
CFM [L/s]	3400 [1604]	3400 [1604]	3400 [1604]	3400 [1604]
No. Motors/HP	1 at 1/3 HP	1 at 1/3 HP	1 at 1/3 HP	1 at 1/3 HP
Motor RPM	875	875	875	875
<b>Indoor Fan - Type</b>	FC Centrifugal	FC Centrifugal	FC Centrifugal	FC Centrifugal
No. Used/Diameter in. [mm]	1/10x9 [254x228.6]	1/10x9 [254x228.6]	1/10x9 [254x228.6]	1/10x9 [254x228.6]
Drive Type/No. Speeds	Direct/2	Direct/2	Direct/2	Direct/2
No. Motors	1	1	1	1
Motor HP	1/4	1/3	1/2	1/2
Motor RPM	1033	1080	1050	1050
Motor Frame Size	48	48	48	48
<b>Filter - Type</b>	Field Supplied	Field Supplied	Field Supplied	Field Supplied
Furnished	No	No	No	No
(NO.) Size Recommended in. [mm x mm x mm]	(1)1x20x16 [25x508x406]	(1)1x20x20 [25x508x508]	(1)1x24x24 [25x610x610]	(1)1x24x24 [25x610x610]
<b>Refrigerant Charge Oz. [g] (R-410A)</b>	70 [1984]	78 [2211]	78 [2211]	78 [2211]
<b>Weights</b>				
Net Weight lbs. [kg]	304 [138]	306 [139]	309 [140]	309 [140]
Ship Weight lbs. [kg]	328 [149]	330 [150]	333 [151]	333 [151]

### NOTES:

1. Cooling Performance is rated at 95°F ambient, 80°F entering dry bulb, 67°F entering wet bulb. Gross capacity does not include the effect of fan motor heat. ARI capacity is net and includes the effect of fan motor heat. Units are suitable for operation to ±20% of nominal cfm. Units are certified in accordance with the Unitary Air Conditioner Equipment certification program, which is based on ARI Standard 210/240 or 360.
2. EER and/or SEER are rated at ARI conditions and in accordance with DOE test procedures.
3. Outdoor Sound Rating shown is tested in accordance with ARI Standard 270.
4. Standard 3/4" PVC P-Trap provided.

[ ] Designates Metric Conversions

# GENERAL DATA - RSNM

## NOMINAL SIZES 2-5 TONS [7-17.6 kW]

Model RSNM- Series	A042CK	A042JK	A048CK	A048JK
<b>Cooling Performance<sup>1</sup></b>				Continued ->
Gross Cooling Capacity Btu [kW]	43,000 [12.6]	43,000 [12.6]	48,000 [14.06]	48,000 [14.06]
EER/SEER <sup>2</sup>	11.1/13	11.1/13	11.3/13	11.3/13
Nominal CFM/ARI Rated CFM [L/s]	1400/1400 [661/661]	1400/1400 [661/661]	1600/1550 [755/731]	1600/1550 [755/731]
ARI Net Cooling Capacity Btu [kW]	41,500 [12.16]	41,500 [12.16]	46,000 [13.48]	46,000 [13.48]
Net Sensible Capacity Btu [kW]	31,500 [9.23]	31,500 [9.23]	35,500 [10.4]	35,500 [10.4]
Net Latent Capacity Btu [kW]	10,000 [2.93]	10,000 [2.93]	10,500 [3.08]	10,500 [3.08]
Net System Power kW	3.74	3.74	4.07	4.07
<b>Compressor</b>				
No./Type	1/Copeland Scroll	1/Copeland Scroll	1/Copeland Scroll	1/Copeland Scroll
<b>Outdoor Sound Rating (dB)<sup>3</sup></b>	76	76	78	78
<b>Outdoor Coil - Fin Type</b>	Louvered	Louvered	Louvered	Louvered
Tube Type	Rifled	Rifled	Rifled	Rifled
Tube Size in. [mm] OD	0.375 [9.5]	0.375 [9.5]	0.375 [9.5]	0.375 [9.5]
Face Area sq. ft. [sq. m]	12.65 [1.18]	12.65 [1.18]	16.54 [1.54]	16.54 [1.54]
Rows / FPI [FPcm]	1 / 22 [9]	1 / 22 [9]	1 / 22 [9]	1 / 22 [9]
<b>Indoor Coil - Fin Type</b>	Louvered	Louvered	Louvered	Louvered
Tube Type	Rifled	Rifled	Rifled	Rifled
Tube Size in. [mm]	0.375 [9.5]	0.375 [9.5]	0.375 [9.5]	0.375 [9.5]
Face Area sq. ft. [sq. m]	5.78 [0.54]	5.78 [0.54]	5.78 [0.54]	5.78 [0.54]
Rows / FPI [FPcm]	3 / 13 [5]	3 / 13 [5]	3 / 13 [5]	3 / 13 [5]
Refrigerant Control	TX Valves	TX Valves	TX Valves	TX Valves
Drain Connection No./Size in. [mm] <sup>4</sup>	1/1 [25.4]	1/1 [25.4]	1/1 [25.4]	1/1 [25.4]
<b>Outdoor Fan - Type</b>	Propeller	Propeller	Propeller	Propeller
No. Used/Diameter in. [mm]	1/24 [609.6]	1/24 [609.6]	1/24 [609.6]	1/24 [609.6]
Drive Type/No. Speeds	Direct/1	Direct/1	Direct/1	Direct/1
CFM [L/s]	3400 [1604]	3400 [1604]	4200 [1982]	4200 [1982]
No. Motors/HP	1 at 1/3 HP	1 at 1/3 HP	1 at 1/3 HP	1 at 1/3 HP
Motor RPM	875	875	1075	1075
<b>Indoor Fan - Type</b>	FC Centrifugal	FC Centrifugal	FC Centrifugal	FC Centrifugal
No. Used/Diameter in. [mm]	1/11x9 [279.4x228.6]	1/11x9 [279.4x228.6]	1/11x9 [279.4x228.6]	1/11x9 [279.4x228.6]
Drive Type/No. Speeds	Direct/2	Direct/2	Direct/2	Direct/2
No. Motors	1	1	1	1
Motor HP	1/2	1/2	3/4	3/4
Motor RPM	1075	1075	1075	1075
Motor Frame Size	48	48	48	48
<b>Filter - Type</b>	Field Supplied	Field Supplied	Field Supplied	Field Supplied
Furnished	No	No	No	No
(NO.) Size Recommended in. [mm x mm x mm]	(1)1x24x24 [25x610x610]	(1)1x24x24 [25x610x610]	(1)1x24x24 [25x610x610]	(1)1x24x24 [25x610x610]
<b>Refrigerant Charge Oz. [g] (R-410A)</b>	86 [2438]	86 [2438]	114 [3232]	114 [3232]
<b>Weights</b>				
Net Weight lbs. [kg]	333 [151]	333 [151]	349 [158]	349 [158]
Ship Weight lbs. [kg]	357 [162]	357 [162]	375 [170]	375 [170]

### NOTES:

- Cooling Performance is rated at 95°F ambient, 80°F entering dry bulb, 67°F entering wet bulb. Gross capacity does not include the effect of fan motor heat. ARI capacity is net and includes the effect of fan motor heat. Units are suitable for operation to ±20% of nominal cfm. Units are certified in accordance with the Unitary Air Conditioner Equipment certification program, which is based on ARI Standard 210/240 or 360.
- EER and/or SEER are rated at ARI conditions and in accordance with DOE test procedures.
- Outdoor Sound Rating shown is tested in accordance with ARI Standard 270.
- Standard 3/4" PVC P-Trap provided.

[ ] Designates Metric Conversions

# GENERAL DATA - RSNM

## NOMINAL SIZES 2-5 TONS [7-17.6 kW]

Model RSNM- Series	A060CK	A060JK
<b>Cooling Performance<sup>1</sup></b>		
Gross Cooling Capacity Btu [kW]	63,000 [18.46]	63,000 [18.46]
EER/SEER <sup>2</sup>	11.3/13	11.3/13
Nominal CFM/ARI Rated CFM [L/s]	2000/1900 [944/897]	2000/1900 [944/897]
ARI Net Cooling Capacity Btu [kW]	60,000 [17.58]	60,000 [17.58]
Net Sensible Capacity Btu [kW]	45,000 [13.18]	45,000 [13.18]
Net Latent Capacity Btu [kW]	15,000 [4.4]	15,000 [4.4]
Net System Power kW	5.31	5.31
<b>Compressor</b>		
No./Type	1/Copeland Scroll	1/Copeland Scroll
<b>Outdoor Sound Rating (dB)<sup>3</sup></b>		
	78	78
<b>Outdoor Coil - Fin Type</b>		
	Louvered	Louvered
Tube Type	Rifled	Rifled
Tube Size in. [mm] OD	0.375 [9.5]	0.375 [9.5]
Face Area sq. ft. [sq. m]	16.54 [1.54]	16.54 [1.54]
Rows / FPI [FPcm]	2 / 22 [9]	2 / 22 [9]
<b>Indoor Coil - Fin Type</b>		
	Louvered	Louvered
Tube Type	Rifled	Rifled
Tube Size in. [mm]	0.375 [9.5]	0.375 [9.5]
Face Area sq. ft. [sq. m]	5.78 [0.54]	5.78 [0.54]
Rows / FPI [FPcm]	4 / 13 [5]	4 / 13 [5]
Refrigerant Control	TX Valves	TX Valves
Drain Connection No./Size in. [mm] <sup>4</sup>	1/1 [25.4]	1/1 [25.4]
<b>Outdoor Fan - Type</b>		
	Propeller	Propeller
No. Used/Diameter in. [mm]	1/24 [609.6]	1/24 [609.6]
Drive Type/No. Speeds	Direct/1	Direct/1
CFM [L/s]	4000 [1888]	4000 [1888]
No. Motors/HP	1 at 1/3 HP	1 at 1/3 HP
Motor RPM	1075	1075
<b>Indoor Fan - Type</b>		
	FC Centrifugal	FC Centrifugal
No. Used/Diameter in. [mm]	1/11x9 [279.4x228.6]	1/11x9 [279.4x228.6]
Drive Type/No. Speeds	Direct/2	Direct/2
No. Motors	1	1
Motor HP	3/4	3/4
Motor RPM	1075	1075
Motor Frame Size	48	48
<b>Filter - Type</b>		
	Field Supplied	Field Supplied
Furnished	No	No
(NO.) Size Recommended in. [mm x mm x mm]	(1)1x24x24 [25x610x610]	(1)1x24x24 [25x610x610]
<b>Refrigerant Charge Oz. [g] (R-410A)</b>		
	178 [5046]	178 [5046]
<b>Weights</b>		
Net Weight lbs. [kg]	364 [165]	364 [165]
Ship Weight lbs. [kg]	390 [177]	390 [177]

### NOTES:

1. Cooling Performance is rated at 95°F ambient, 80°F entering dry bulb, 67°F entering wet bulb. Gross capacity does not include the effect of fan motor heat. ARI capacity is net and includes the effect of fan motor heat. Units are suitable for operation to ±20% of nominal cfm. Units are certified in accordance with the Unitary Air Conditioner Equipment certification program, which is based on ARI Standard 210/240 or 360.
2. EER and/or SEER are rated at ARI conditions and in accordance with DOE test procedures.
3. Outdoor Sound Rating shown is tested in accordance with ARI Standard 270.
4. Standard 3/4" PVC P-Trap provided.

[ ] Designates Metric Conversions

# GENERAL DATA - RSPM

## NOMINAL SIZES 2-5 TONS [7-17.6 kW]

Model RSPM- Series	A024JK	A030JK	A036CK	A036JK
<b>Cooling Performance<sup>1</sup></b>				Continued ->
Gross Cooling Capacity Btu [kW]	25,200 [7.38]	30,400 [8.91]	37,600 [11.02]	37,600 [11.02]
EER/SEER <sup>2</sup>	12.4/14	12.25/14	12.2/14	12.2/14
Nominal CFM/ARI Rated CFM [L/s]	800/800 [378/378]	1000/1000 [472/472]	1200/1200 [566/566]	1200/1200 [566/566]
ARI Net Cooling Capacity Btu [kW]	24,200 [7.09]	29,200 [8.56]	36,200 [10.61]	36,200 [10.61]
Net Sensible Capacity Btu [kW]	18,800 [5.51]	23,000 [6.74]	27,700 [8.12]	27,700 [8.12]
Net Latent Capacity Btu [kW]	5,400 [1.58]	6,200 [1.82]	8,500 [2.49]	8,500 [2.49]
Net System Power kW	1.95	2.38	2.97	2.97
<b>Compressor</b>				
No./Type	1/Copeland Scroll	1/Copeland Scroll	1/Copeland Scroll	1/Copeland Scroll
<b>Outdoor Sound Rating (dB)<sup>3</sup></b>	76	76	76	76
<b>Outdoor Coil - Fin Type</b>	Louvered	Louvered	Louvered	Louvered
Tube Type	Rifled	Rifled	Rifled	Rifled
Tube Size in. [mm] OD	0.375 [9.5]	0.375 [9.5]	0.375 [9.5]	0.375 [9.5]
Face Area sq. ft. [sq. m]	10.44 [0.97]	12.64 [1.17]	12.65 [1.18]	12.65 [1.18]
Rows / FPI [FPcm]	1 / 20 [8]	1 / 22 [9]	1 / 22 [9]	1 / 22 [9]
<b>Indoor Coil - Fin Type</b>	Louvered	Louvered	Louvered	Louvered
Tube Type	Rifled	Rifled	Rifled	Rifled
Tube Size in. [mm]	0.375 [9.5]	0.375 [9.5]	0.375 [9.5]	0.375 [9.5]
Face Area sq. ft. [sq. m]	4.33 [0.4]	4.33 [0.4]	4.33 [0.4]	4.33 [0.4]
Rows / FPI [FPcm]	2 / 15 [6]	2 / 15 [6]	2 / 15 [6]	2 / 15 [6]
Refrigerant Control	TX Valves	TX Valves	TX Valves	TX Valves
Drain Connection No./Size in. [mm] <sup>4</sup>	1/1 [25.4]	1/1 [25.4]	1/1 [25.4]	1/1 [25.4]
<b>Outdoor Fan - Type</b>	Propeller	Propeller	Propeller	Propeller
No. Used/Diameter in. [mm]	1/24 [609.6]	1/24 [609.6]	1/24 [609.6]	1/24 [609.6]
Drive Type/No. Speeds	Direct/1	Direct/1	Direct/1	Direct/1
CFM [L/s]	3400 [1604]	3400 [1604]	3400 [1604]	3400 [1604]
No. Motors/HP	1 at 1/3 HP	1 at 1/3 HP	1 at 1/3 HP	1 at 1/3 HP
Motor RPM	875	875	875	875
<b>Indoor Fan - Type</b>	FC Centrifugal	FC Centrifugal	FC Centrifugal	FC Centrifugal
No. Used/Diameter in. [mm]	1/10x9 [254x228.6]	1/10x9 [254x228.6]	1/10x9 [254x228.6]	1/10x9 [254x228.6]
Drive Type/No. Speeds	Direct/2	Direct/2	Direct/2	Direct/2
No. Motors	1	1	1	1
Motor HP	1/4	1/3	1/2	1/2
Motor RPM	1050	1050	1050	1050
Motor Frame Size	48	48	48	48
<b>Filter - Type</b>	Field Supplied	Field Supplied	Field Supplied	Field Supplied
Furnished	No	No	No	No
(NO.) Size Recommended in. [mm x mm x mm]	(1)1x20x16 [25x508x406]	(1)1x20x20 [25x508x508]	(1)1x24x24 [25x610x610]	(1)1x24x24 [25x610x610]
<b>Refrigerant Charge Oz. [g] (R-410A)</b>	70 [1984]	78 [2211]	78 [2211]	78 [2211]
<b>Weights</b>				
Net Weight lbs. [kg]	304 [138]	306 [139]	309 [140]	309 [140]
Ship Weight lbs. [kg]	328 [149]	330 [150]	333 [151]	333 [151]

### NOTES:

- Cooling Performance is rated at 95°F ambient, 80°F entering dry bulb, 67°F entering wet bulb. Gross capacity does not include the effect of fan motor heat. ARI capacity is net and includes the effect of fan motor heat. Units are suitable for operation to ±20% of nominal cfm. Units are certified in accordance with the Unitary Air Conditioner Equipment certification program, which is based on ARI Standard 210/240 or 360.
- EER and/or SEER are rated at ARI conditions and in accordance with DOE test procedures.
- Outdoor Sound Rating shown is tested in accordance with ARI Standard 270.
- Standard 3/4" PVC P-Trap provided.

[ ] Designates Metric Conversions

# GENERAL DATA - RSPM

## NOMINAL SIZES 2-5 TONS [7-17.6 kW]

Model RSPM - Series	B042CK	B042JK	A043CK	A043JK
<b>Cooling performance<sup>1</sup></b>				<b>Continued -&gt;</b>
Gross Cooling Capacity Btu [kW]	43,500 [12.75]	43,500 [12.75]	43,000 [12.6]	43,000 [12.6]
EER, SEER <sup>2</sup>	11.85/14	11.85/14	12/14	12/14
Nominal CFM/ARI Rated CFM [L/s]	1400/1400 [661/661]	1400/1400 [661/661]	1400/1400 [661/661]	1400/1400 [661/661]
ARI Net Cooling Capacity Btu [kW]	42,000 [12.31]	42,000 [12.31]	42,000 [12.31]	42,000 [12.31]
Net Sensible Capacity Btu [kW]	32,500 [9.52]	32,500 [9.52]	32,500 [9.52]	32,500 [9.52]
Net Latent Capacity Btu [kW]	9,500 [2.78]	9,500 [2.78]	10,000 [2.93]	10,000 [2.93]
Net System Power kW	3.53	3.53	3.5	3.5
<b>Compressor</b>				
No./Type	1/Copeland Scroll	1/Copeland Scroll	1/Scroll	1 Scroll
<b>Outdoor Sound Rating (dB)<sup>5</sup></b>	76	76	76	76
<b>Outdoor Coil - Fin Type</b>	Louvered	Louvered	Louvered	Louvered
Tube Type	Rifled	Rifled	Rifled	Rifled
Tube Size in. [mm] OD	0.375 [9.5]	0.375 [9.5]	0.375 [9.5]	0.375 [9.5]
Face Area sq. ft. [sq. m]	12.65 [1.18]	12.65 [1.18]	12.65 [1.18]	12.65 [1.18]
Rows / FPI [FPcm]	1 / 22 [9]	1 / 22 [9]	1 / 22 [9]	1 / 22 [9]
<b>Indoor Coil - Fin Type</b>	Louvered	Louvered	Louvered	Louvered
Tube Type	Rifled	Rifled	Rifled	Rifled
Tube Size in. [mm]	0.375 [9.5]	0.375 [9.5]	0.375 [9.5]	0.375 [9.5]
Face Area sq. ft. [sq. m]	5.78 [0.54]	5.78 [0.54]	5.78 [0.54]	5.78 [0.54]
Rows / FPI [FPcm]	3 / 13 [5]	3 / 13 [5]	3 / 13 [5]	3 / 13 [5]
Refrigerant Control	TX Valves	TX Valves	TX Valves	TX Valves
Drain Connection No./Size in. [mm]	1/1 [25.4]	1/1 [25.4]	1/1 [25.4]	1/1 [25.4]
<b>Outdoor Fan - Type</b>	Propeller	Propeller	Propeller	Propeller
No. Used/Diameter in. [mm]	1/24 [609.6]	1/24 [609.6]	1/24 [609.6]	1/24 [609.6]
Drive Type/No. Speeds	Direct/1	Direct/1	Direct/1	Direct/1
CFM [L/s]	3400 [1604]	3400 [1604]	3400 [1604]	3400 [1604]
No. Motors/HP	1 at 1/3 HP	1 at 1/3 HP	1 at 1/3 HP	1 at 1/3 HP
Motor RPM	875	875	850	850
<b>Indoor Fan - Type</b>	FC Centrifugal	FC Centrifugal	FC Centrifugal	FC Centrifugal
No. Used/Diameter in. [mm]	1/11x9 [279.4x228.6]	1/11x9 [279.4x228.6]	1/11x9 [279x229]	1/11x9 [279x229]
Drive Type/No. Speeds	Direct/2	Direct/2	Direct/2	Direct/2
No. Motors	1	1	1	1
Motor HP	1/2	1/2	1/2	1/2
Motor RPM	1050	1050	1075	1075
Motor Frame Size	48	48	48	48
<b>Filter - Type</b>	Field Supplied	Field Supplied	Field Supplied	Field Supplied
Furnished	No	No	No	No
(NO.) Size Recommended in. [mm x mm x mm]	(1)1x24x24 [25x610x610]	(1)1x24x24 [25x610x610]	(1)1x24x24 [25x610x610]	(1)1x24x24 [25x610x610]
<b>Refrigerant Charge Oz. [g]</b>	86 [2438]	86 [2438]	86 [2438]	86 [2438]
<b>Weights</b>				
Net Weight lbs. [kg]	333 [151]	333 [151]	333 [151]	333 [151]
Ship Weight lbs. [kg]	357 [162]	357 [162]	357 [162]	357 [162]

### NOTES:

1. Cooling Performance is rated at 95°F ambient, 80°F entering dry bulb, 67°F entering wet bulb. Gross capacity does not include the effect of fan motor heat. ARI capacity is net and includes the effect of fan motor heat. Units are suitable for operation to ±20% of nominal cfm. Units are certified in accordance with the Unitary Air Conditioner Equipment certification program, which is based on ARI Standard 210/240 or 360.
2. EER and/or SEER are rated at ARI conditions and in accordance with DOE test procedures.
3. Outdoor Sound Rating shown is tested in accordance with ARI Standard 270.
4. Standard 3/4" PVC P-Trap provided.

[ ] Designates Metric Conversions

# GENERAL DATA - RSPM

## NOMINAL SIZES 2-5 TONS [7-17.6 kW]

Model RSPM - Series	A048CK	A048JK	A060CK	A060JK
<b>Cooling performance<sup>1</sup></b>				
Gross Cooling Capacity Btu [kW]	49,000 [14.36]	49,000 [14.36]	64,000 [18.75]	64,000 [18.75]
EER, SEER <sup>2</sup>	12.6/14	12.6/14	12.35/14	12.35/14
Nominal CFM/ARI Rated CFM [L/s]	1600/1600 [755/755]	1600/1600 [755/755]	2000/1900 [944/897]	2000/1900 [944/897]
ARI Net Cooling Capacity Btu [kW]	47,000 [13.77]	47,000 [13.77]	61,000 [17.87]	61,000 [17.87]
Net Sensible Capacity Btu [kW]	36,400 [10.67]	36,400 [10.67]	45,500 [13.33]	45,500 [13.33]
Net Latent Capacity Btu [kW]	10,600 [3.11]	10,600 [3.11]	15,500 [4.54]	15,500 [4.54]
Net System Power kW	3.61	3.61	4.94	4.94
<b>Compressor</b>				
No./Type	1/Copeland Scroll	1/Copeland Scroll	1/Copeland Scroll	1/Copeland Scroll
<b>Outdoor Sound Rating (dB)<sup>5</sup></b>				
	78	78	78	78
<b>Outdoor Coil - Fin Type</b>				
Tube Type	Louvered	Louvered	Louvered	Louvered
Tube Size in. [mm] OD	Rifled	Rifled	Rifled	Rifled
Face Area sq. ft. [sq. m]	0.375 [9.5]	0.375 [9.5]	0.375 [9.5]	0.375 [9.5]
Rows / FPI [FPcm]	16.54 [1.54]	16.54 [1.54]	16.54 [1.54]	16.54 [1.54]
	1 / 22 [9]	1 / 22 [9]	2 / 22 [9]	2 / 22 [9]
<b>Indoor Coil - Fin Type</b>				
Tube Type	Louvered	Louvered	Louvered	Louvered
Tube Size in. [mm]	Rifled	Rifled	Rifled	Rifled
Face Area sq. ft. [sq. m]	0.375 [9.5]	0.375 [9.5]	0.375 [9.5]	0.375 [9.5]
Rows / FPI [FPcm]	5.78 [0.54]	5.78 [0.54]	5.78 [0.54]	5.78 [0.54]
Refrigerant Control	3 / 13 [5]	3 / 13 [5]	4 / 13 [5]	4 / 13 [5]
Drain Connection No./Size in. [mm]	TX Valves	TX Valves	TX Valves	TX Valves
	1/1 [25.4]	1/1 [25.4]	1/1 [25.4]	1/1 [25.4]
<b>Outdoor Fan - Type</b>				
No. Used/Diameter in. [mm]	Propeller	Propeller	Propeller	Propeller
Drive Type/No. Speeds	1/24 [609.6]	1/24 [609.6]	1/24 [609.6]	1/24 [609.6]
CFM [L/s]	Direct/1	Direct/1	Direct/1	Direct/1
No. Motors/HP	4200 [1982]	4200 [1982]	4000 [1888]	4000 [1888]
Motor RPM	1 at 1/3 HP	1 at 1/3 HP	1 at 1/3 HP	1 at 1/3 HP
	1075	1075	1075	1075
<b>Indoor Fan - Type</b>				
No. Used/Diameter in. [mm]	FC Centrifugal	FC Centrifugal	FC Centrifugal	FC Centrifugal
Drive Type/No. Speeds	1/11x9 [279.4x228.6]	1/11x9 [279.4x228.6]	1/11x9 [279.4x228.6]	1/11x9 [279.4x228.6]
No. Motors	Direct/2	Direct/2	Direct/2	Direct/2
Motor HP	1	1	1	1
Motor RPM	3/4	3/4	3/4	3/4
Motor Frame Size	1050	1050	1050	1050
	48	48	48	48
<b>Filter - Type</b>				
Furnished	Field Supplied	Field Supplied	Field Supplied	Field Supplied
(NO.) Size Recommended in. [mm x mm x mm]	No	No	No	No
	(1)1x24x24 [25x610x610]	(1)1x24x24 [25x610x610]	(1)1x24x24 [25x610x610]	(1)1x24x24 [25x610x610]
<b>Refrigerant Charge Oz. [g]</b>				
	114 [3232]	114 [3232]	178 [5046]	178 [5046]
<b>Weights</b>				
Net Weight lbs. [kg]	349 [158]	349 [158]	364 [165]	364 [165]
Ship Weight lbs. [kg]	375 [170]	375 [170]	390 [177]	390 [177]

### NOTES:

- Cooling Performance is rated at 95°F ambient, 80°F entering dry bulb, 67°F entering wet bulb. Gross capacity does not include the effect of fan motor heat. ARI capacity is net and includes the effect of fan motor heat. Units are suitable for operation to ±20% of nominal cfm. Units are certified in accordance with the Unitary Air Conditioner Equipment certification program, which is based on ARI Standard 210/240 or 360.
- EER and/or SEER are rated at ARI conditions and in accordance with DOE test procedures.
- Outdoor Sound Rating shown is tested in accordance with ARI Standard 270.
- Standard 3/4" PVC P-Trap provided.

[ ] Designates Metric Conversions



# XVI. MISCELLANEOUS

## ELECTRICAL DATA

ELECTRICAL DATA - RSNM SERIES											
		-A024JK	-A030JK	-A036CK	-A036JK	-A042CK	-A042JK	-A048CK	-A048JK	-A060CK	-A060JK
Unit Information	Unit Operating Voltage Range	187-253	187-253	187-253	187-253	187-253	187-253	187-253	187-253	187-253	187-253
	Minimum Circuit Ampacity	20/20	21/21	20/20	26/26	22/22	27/27	24/24	32/32	28/28	41/41
	Minimum Overcurrent Protection Device Size	25/25	25/25	25/25	30/30	25/25	35/35	30/30	40/40	35/35	50/50
	Maximum Overcurrent Protection Device Size	30/30	35/35	30/30	40/40	30/30	40/40	35/35	50/50	40/40	60/60
Compressor Motor	No.	1	1	1	1	1	1	1	1	1	1
	Volts	208/230	208/230	208/230	208/230	208/230	208/230	208/230	208/230	208/230	208/230
	Phase	1	1	3	1	3	1	3	1	3	1
	HP	2	2.5	3	3	3.5	3.5	4	4	4.5	4.5
	RPM	3450	3450	3450	3450	3450	3450	3450	3450	3450	3450
	Amps (RLA)	13.5/13.5	14.1/14.1	12.8/12.8	17/17	13.5/13.5	17.9/17.9	14.7/14.7	21.2/21.2	16/16	26.4/26.4
	Amps (LRA)	54/54	73/73	95/95	96.7/96.7	88/88	112/112	115/115	115/115	110/110	134/134
Condenser Motor	No.	1	1	1	1	1	1	1	1	1	1
	Volts	208/230	208/230	208/230	208/230	208/230	208/230	208/230	208/230	208/230	208/230
	Phase	1	1	1	1	1	1	1	1	1	1
	HP	1/3	1/3	1/3	1/3	1/3	1/3	1/3	1/3	1/3	1/3
	Amps (FLA)	1.5	1.5	1.5	1.5	1.5	1.5	1.9	1.9	1.9	1.9
	Amps (LRA)	3	3	3	3	3	3	4	4	4	4
Evaporator Fan	No.	1	1	1	1	1	1	1	1	1	1
	Volts	208/230	208/230	208/230	208/230	208/230	208/230	208/230	208/230	208/230	208/230
	Phase	1	1	1	1	1	1	1	1	1	1
	HP	1/4	1/3	1/2	1/2	1/2	1/2	3/4	3/4	3/4	3/4
	Amps (FLA)	1.5	1.8	2.5	2.5	2.8	2.8	3.2	3.2	5.8	5.8
	Amps (LRA)	2.5	2.6	4.9	4.9	4.3	4.3	4.1	4.1	9	9

## ELECTRICAL DATA - continued

ELECTRICAL DATA – RSPM SERIES													
		-A024JK	-A030JK	-A036CK	-A036JK	-A042CK	-A042JK	A043CK	A043JK	-A048CK	-A048JK	-A060CK	-A060JK
<b>Unit Information</b>	Unit Operating Voltage Range	187-253	187-253	187-253	187-253	187-253	187-253	187-253	187-253	187-253	187-253	187-253	187-253
	Volts							208/230	208/230				
	Minimum Circuit Ampacity	23/23	24/24	22/22	27/27	25/25	30/30	25/25	30/30	27/27	35/35	30/30	43/43
	Minimum Overcurrent Protection Device Size	30/30	30/30	25/25	35/35	30/30	35/35	30/30	35/35	30/30	40/40	35/35	50/50
	Maximum Overcurrent Protection Device Size	35/35	35/35	30/30	40/40	35/35	45/45	35/35	45/45	40/40	50/50	45/45	60/60
<b>Compressor Motor</b>	No.	1	1	1	1	1	1	1	1	1	1	1	1
	Volts	208/230	208/230	208/230	200/230	208/230	208/230	208/230	208/230	208/230	208/230	208/230	208/230
	Phase	1	1	3	1	3	1	3	1	3	1	3	1
	HP	2	2.5	3	3	3.5	3.5	3 1/2	3.5	4	4	4.5	4.5
	RPM	3450	3450	3450	3450	3450	3450	3450	3450	3450	3450	3450	3450
	Amps (RLA), Comp. 1	13.5/13.5	14.1/14.1	12.8/12.8	17/17	13.5/13.5	17.9/17.9	13.5/13.5	17.9/17.9	14.7/14.7	21.2/21.2	16/16	26.4/26.4
	Amps (LRA), Comp. 1	58.3/58.3	73/73	95/95	96.7/96.7	88/88	112/112	88/88	112/112	115/115	115/115	110/110	134/134
<b>Condenser Motor</b>	No.	1	1	1	1	1	1	1	1	1	1	1	1
	Volts	208/230	208/230	208/230	208/230	208/230	208/230	208/230	208/230	208/230	208/230	208/230	208/230
	Phase	1	1	1	1	1	1	1	1	1	1	1	1
	HP	1/3	1/3	1/3	1/3	1/3	1/3	1/3	1/3	1/3	1/3	1/3	1/3
	Amps (FLA, each)	1.5	1.5	1.5	1.5	1.5	1.5	1.5/1.5	1.5/1.5	1.9	1.9	1.9	1.9
	Amps (LRA, each)	3	3	3	3	3	3	3/3	3/3	4	4	4	4
<b>Evaporator Fan</b>	No.	1	1	1	1	1	1	1	1	1	1	1	1
	Volts	208/230	208/230	208/230	208/230	208/230	208/230	208/230	208/230	208/230	208/230	208/230	208/230
	Phase	1	1	1	1	1	1	1	1	1	1	1	1
	HP	1/4	1/3	1/2	1/2	1/2	1/2	1/2	1/2	3/4	3/4	3/4	3/4
	Amps (FLA, each)	4.1	4.1	4.1	4.1	6	6	6/6	6/6	6	6	7.6	7.6
	Amps (FLA, each)							0/0	0/0				

- 1 Horsepower per Compressor
2. Amp Draw Per Motor. Multiply Value by Number of Motors to Determine Total Amps.

# AUXILIARY ELECTRIC HEATER KITS CHARACTERISTICS AND APPLICATION – RSNM

<b>208-240 VOLT, SINGLE PHASE, 60 HZ, AUXILIARY ELECTRIC HEATER KITS CHARACTERISTICS AND APPLICATION</b>														
Model No. RSNM-	Single Power Supply For Both Unit And Heater Kit							Separate Power Supply For Both Unit And Heater Kit						
	Heater Kit Nominal kW RXQJ-C	No. of Elements	No. of Sequence Steps	Rated Heater kW @ 208-240 V	Heater KBTU/Hr @ 208-240 V	Heater Amp. @ 208 V	Unit Min. Ckt Ampacity @ 208-240 V	Over Current Protective Device Size Min/Max @ 208 V	Heater Kit Min. Ckt. Ampacity	Heater Kit Max. Fuse Size	Heat Pump Min. Ckt. Ampacity 208 V	Heat Pump Over Current Protective Device Size Min/Max @ 208 V	Model No. RSNM-	
A024J	No Heat	-	-	-	-	-	20/20	25/30	-	-	20/20	25/30	-	
	05J	1	1	3.6/4.8	12.28/16.38	17.33/20	24/27	25/30	25/25	25/25	-	-	-	
	07J	1	1	5.4/7.2	18.42/24.56	26/30	35/40	35/35	35/40	35/40	-	-	-	
A030J	10J	2	1	7.2/9.6	24.57/32.76	34.7/40	46/52	50/50	45/50	45/50	-	-	-	
	No Heat	-	-	-	-	-	21/21	25/35	-	-	21/21	25/35	-	
	05J	1	1	3.6/4.8	12.28/16.38	17.33/20	24/28	25/35	25/25	25/25	-	-	-	
A036J	07J	1	1	5.4/7.2	18.42/24.56	26/30	35/40	35/35	35/40	33/38	-	-	-	
	10J	2	1	7.2/9.6	24.57/32.76	34.7/40	46/53	50/50	45/50	44/50	-	-	-	
	15J	3	2	10.8/14.4	36.85/49.13	52/60	68/78	70/70	70/80	65/75	-	-	-	
A042J	No Heat	-	-	-	-	-	26/26	30/40	-	-	26/26	30/40	-	
	05J	1	1	3.6/4.8	12.28/16.38	17.33/20	26/29	30/40	25/25	25/25	-	-	-	
	07J	1	1	5.4/7.2	18.42/24.56	26/30	36/41	40/40	35/40	33/38	-	-	-	
A048J	10J	2	1	7.2/9.6	24.57/32.76	34.7/40	47/54	50/50	45/50	44/50	-	-	-	
	15J	3	2	10.8/14.4	36.85/49.13	52/60	69/79	70/70	70/80	65/75	-	-	-	
	20J	4	2	14.4/19.2	49.12/65.52	69.33/80	91/104	100/100	90/100	87/100	-	-	-	
A060J	No Heat	-	-	-	-	-	32/32	40/50	-	-	32/32	40/50	-	
	05J	1	1	3.6/4.8	12.28/16.38	17.33/20	32/32	35/45	25/25	22/25	-	-	-	
	07J	1	1	5.4/7.2	18.42/24.56	26/30	37/42	40/45	35/40	33/38	-	-	-	
A060J	10J	2	1	7.2/9.6	24.57/32.76	34.7/40	48/54	50/50	45/50	44/50	-	-	-	
	15J	3	2	10.8/14.4	36.85/49.13	52/60	69/79	70/70	70/80	65/75	-	-	-	
	20J	4	2	14.4/19.2	49.12/65.52	69.33/80	91/104	100/100	90/100	87/100	-	-	-	
A060J	No Heat	-	-	-	-	-	41/41	50/60	-	-	0	50/60	-	
	05J	1	1	3.6/4.8	12.28/16.38	17.33/20	41/41	50/60	25/25	22/25	-	-	-	
	07J	1	1	5.4/7.2	18.42/24.56	26/30	41/45	50/60	35/40	33/38	-	-	-	
A060J	10J	2	1	7.2/9.6	24.57/32.76	34.7/40	51/58	60/60	45/50	44/50	-	-	-	
	15J	3	2	10.8/14.4	36.85/49.13	52/60	73/83	80/80	70/80	65/75	-	-	-	
	20J	4	2	14.4/19.2	49.12/65.52	69.33/80	94/108	100/100	90/100	87/100	-	-	-	

# AUXILIARY ELECTRIC HEATER KITS CHARACTERISTICS AND APPLICATION – RSNM

<b>208-240 VOLT, THREE PHASE, 60 HZ, AUXILIARY ELECTRIC HEATER KITS CHARACTERISTICS AND APPLICATION</b>													
Model No. RSNM-	Single Power Supply For Both Unit And Heater Kit						Separate Power Supply For Both Unit And Heater Kit						
	Heater Kit Nominal kW RXQJ-C	No. of Elements	No. of Sequence Steps	Rated Heater kW @ 208-240 V	Heater KBTU/Hr @ 208-240 V	Heater Amp. @ 208 V	Unit Min. Ckt Ampacity @ 208-240 V	Over Current Protective Device Size @ 208 V	Min/Max @ 208 V	Min. Ckt. Ampacity	Heater Kit Max. Fuse Size	Heat Pump Min. Ckt. Ampacity 208 V	Heat Pump Over Current Protective Device Size @ 208 V
A036C	No Heat	-	-	-	-	-	20/20	25/30	25/30	-	-	20/20	25/30
	10C	2	1	7.2/9.6	24.57/32.76	20/23.1	29/32	30/30	35/35	25/29	25/30	-	-
	15C	3	2	10.8/14.4	36.85/49.13	30.1/34.7	41/47	45/45	50/50	38/44	40/45	-	-
A042C	No Heat	-	-	-	-	-	22/22	25/30	25/30	-	-	22/22	25/30
	10C	2	1	7.2/9.6	24.57/32.76	20/23.1	29/33	30/30	35/35	25/29	25/30	-	-
	15C	3	2	10.8/14.4	36.85/49.13	30.1/34.7	42/47	45/45	50/50	38/44	40/45	-	-
	20C	4	2	14.4/19.2	49.12/65.52	40/46.3	54/62	60/60	70/70	50/58	50/60	-	-
A048C	No Heat	-	-	-	-	-	24/24	30/35	30/35	-	-	24/24	30/35
	10C	2	1	7.2/9.6	24.57/32.76	20/23.1	29/33	30/30	35/35	25/29	25/30	-	-
	15C	3	2	10.8/14.4	36.85/49.13	30.1/34.7	42/48	45/45	50/50	38/44	40/45	-	-
	20C	4	2	14.4/19.2	49.12/65.52	40/46.3	54/62	60/60	70/70	50/58	50/60	-	-
A060C	No Heat	-	-	-	-	-	28/28	35/40	35/40	-	-	28/28	35/40
	10C	2	1	7.2/9.6	24.57/32.76	20/23.1	33/37	35/45	40/45	25/29	25/30	-	-
	15C	3	2	10.8/14.4	36.85/49.13	30.1/34.7	45/51	45/45	60/60	38/44	40/45	-	-
	20C	4	2	14.4/19.2	49.12/65.52	40/46.3	58/66	60/60	70/70	50/58	50/60	-	-

# AUXILIARY ELECTRIC HEATER KITS CHARACTERISTICS AND APPLICATION – RSPM

<b>208-240 VOLT, SINGLE PHASE, 60 HZ, AUXILIARY ELECTRIC HEATER KITS CHARACTERISTICS AND APPLICATION</b>													
Model No. RSPM-	Single Power Supply For Both Unit And Heater Kit						Separate Power Supply For Both Unit And Heater Kit						
	Heater Kit Nominal kW RXQJ-C	No. of Elements	No. of Sequence Steps	Rated Heater kW @ 208-240 V	Heater KBTU/Hr @ 208-240 V	Heater Amp. @ 208 V	Unit Min. Ckt Ampacity @ 208-240 V	Over Current Protective Device Size @ 208 V	Min/Max @ 208 V	Min. Ckt. Ampacity	Heater Kit Max. Fuse Size	Heat Pump Min. Ckt. Ampacity 208	Heat Pump Over Current Protective Device Size @ 208 V
A024J	No Heat	-	-	-	-	-	23/23	30/35	30/35	-	-	23/23	30/35
	05J	1	1	3.6/4.8	12.28/16.38	17.33/20	27/31	30/35	35/35	22/25	25/25	-	-
	07J	1	1	5.4/7.2	18.42/24.56	26/30	38/43	40/40	45/45	33/38	35/40	-	-
	10J	2	1	7.2/9.6	24.57/32.76	34.7/40	49/56	50/50	60/60	44/50	45/50	-	-
A030J	No Heat	-	-	-	-	-	24/24	30/35	30/35	-	-	24/24	30/35
	05J	1	1	3.6/4.8	12.28/16.38	17.33/20	27/31	30/35	35/35	22/25	25/25	-	-
	07J	1	1	5.4/7.2	18.42/24.56	26/30	38/43	40/40	45/45	33/38	35/40	-	-
	10J	2	1	7.2/9.6	24.57/32.76	34.7/40	49/56	50/50	60/60	44/50	45/50	-	-
	15J	3	2	10.8/14.4	36.85/49.13	52/60	71/81	80/80	90/90	65/75	70/80	-	-
A036J	No Heat	-	-	-	-	-	27/27	35/40	35/40	-	-	27/27	35/40
	05J	1	1	3.6/4.8	12.28/16.38	17.33/20	27/31	35/40	35/40	22/25	25/25	-	-
	07J	1	1	5.4/7.2	18.42/24.56	26/30	38/43	40/40	45/45	33/38	35/40	-	-
	10J	2	1	7.2/9.6	24.57/32.76	34.7/40	49/56	50/50	60/60	44/50	45/50	-	-
	15J	3	2	10.8/14.4	36.85/49.13	52/60	71/81	80/80	90/90	65/75	70/80	-	-
A042J A043J	No Heat	-	-	-	-	-	30/30	35/45	35/45	-	-	30/30	35/45
	05J	1	1	3.6/4.8	12.28/16.38	17.33/20	30/33	35/45	35/45	22/25	25/25	-	-
	07J	1	1	5.4/7.2	18.42/24.56	26/30	40/45	40/40	45/45	33/38	35/40	-	-
	10J	2	1	7.2/9.6	24.57/32.76	34.7/40	51/58	60/60	60/60	44/50	45/50	-	-
	15J	3	2	10.8/14.4	36.85/49.13	52/60	73/83	80/80	90/90	65/75	70/80	-	-
A048J	No Heat	-	-	-	-	-	95/108	100/100	110/110	87/100	90/100	-	-
	05J	1	1	3.6/4.8	12.28/16.38	17.33/20	35/35	40/50	40/50	-	-	0	40/50
	07J	1	1	5.4/7.2	18.42/24.56	26/30	40/45	40/40	45/45	22/25	25/25	-	-
	10J	2	1	7.2/9.6	24.57/32.76	34.7/40	51/58	60/60	60/60	44/50	45/50	-	-
	15J	3	2	10.8/14.4	36.85/49.13	52/60	73/83	80/80	90/90	65/75	70/80	-	-
A060J	No Heat	-	-	-	-	-	95/108	100/100	110/110	87/100	90/100	-	-
	05J	1	1	3.6/4.8	12.28/16.38	17.33/20	43/43	50/60	50/60	-	-	43/43	50/60
	07J	1	1	5.4/7.2	18.42/24.56	26/30	43/47	50/60	50/60	22/25	25/25	-	-
	10J	2	1	7.2/9.6	24.57/32.76	34.7/40	53/60	60/60	60/60	33/38	35/40	-	-
	15J	3	2	10.8/14.4	36.85/49.13	52/60	75/85	80/80	90/90	44/50	45/50	-	-
20J	4	2	14.4/19.2	49.12/65.52	69.33/80	97/110	100/100	110/110	65/75	70/80	-	-	

# AUXILIARY ELECTRIC HEATER KITS CHARACTERISTICS AND APPLICATION – RSPM

<b>208-240 VOLT, THREE PHASE, 60 HZ, AUXILIARY ELECTRIC HEATER KITS CHARACTERISTICS AND APPLICATION</b>												
Model No. RSPM-	Single Power Supply For Both Unit And Heater Kit						Separate Power Supply For Both Unit And Heater Kit					
	Heater Kit Nominal kW RXQJ-C	No. of Elements	No. of Sequence Steps	Rated Heater kW @ 208-240 V	Heater KBTU/Hr @ 208-240 V	Heater Amp. @ 208 V	Unit Min. Ckt Ampacity @ 208-240 V	Over Current Protective Device Size Min/Max @ 208 V	Heater Kit Min. Ckt. Ampacity	Heater Kit Max. Fuse Size	Heat Pump Min. Ckt. Ampacity 208 V	Heat Pump Over Current Protective Device Size Min/Max @ 240 V
A036C	No Heat	-	-	-	-	-	22/22	25/30	-	-	22/22	25/30
	10C	2	1	7.2/9.6	24.57/32.76	20/23.1	31/34	35/35	25/29	25/30	-	-
	15C	3	2	10.8/14.4	36.85/49.13	30.1/34.7	43/49	45/45	38/44	40/45	-	-
A042C A043C	No Heat	-	-	-	-	-	25/25	30/35	-	-	25/25	30/35
	10C	2	1	7.2/9.6	24.57/32.76	20/23.1	33/37	35/35	25/29	25/30	-	-
	15C	3	2	10.8/14.4	36.85/49.13	30.1/34.7	46/51	50/50	38/44	40/45	-	-
A048C	20C	4	2	14.4/19.2	49.12/65.52	40/46.3	58/66	60/60	50/58	50/60	-	-
	No Heat	-	-	-	-	-	27/27	30/40	-	-	27/27	30/40
	10C	2	1	7.2/9.6	24.57/32.76	20/23.1	33/37	35/35	25/29	25/30	-	-
A060C	15C	3	2	10.8/14.4	36.85/49.13	30.1/34.7	46/51	50/50	38/44	40/45	-	-
	20C	4	2	14.4/19.2	49.12/65.52	40/46.3	58/66	60/60	50/58	50/60	-	-
	No Heat	-	-	-	-	-	30/30	35/45	-	-	30/30	35/45
A060C	10C	2	1	7.2/9.6	24.57/32.76	20/23.1	35/39	35/35	25/29	25/30	-	-
	15C	3	2	10.8/14.4	36.85/49.13	30.1/34.7	48/53	50/50	38/44	40/45	-	-
	20C	4	2	14.4/19.2	49.12/65.52	40/46.3	60/68	60/60	50/58	50/60	-	-

**FIGURE 7**  
**WIRING DIAGRAM - RSNM**

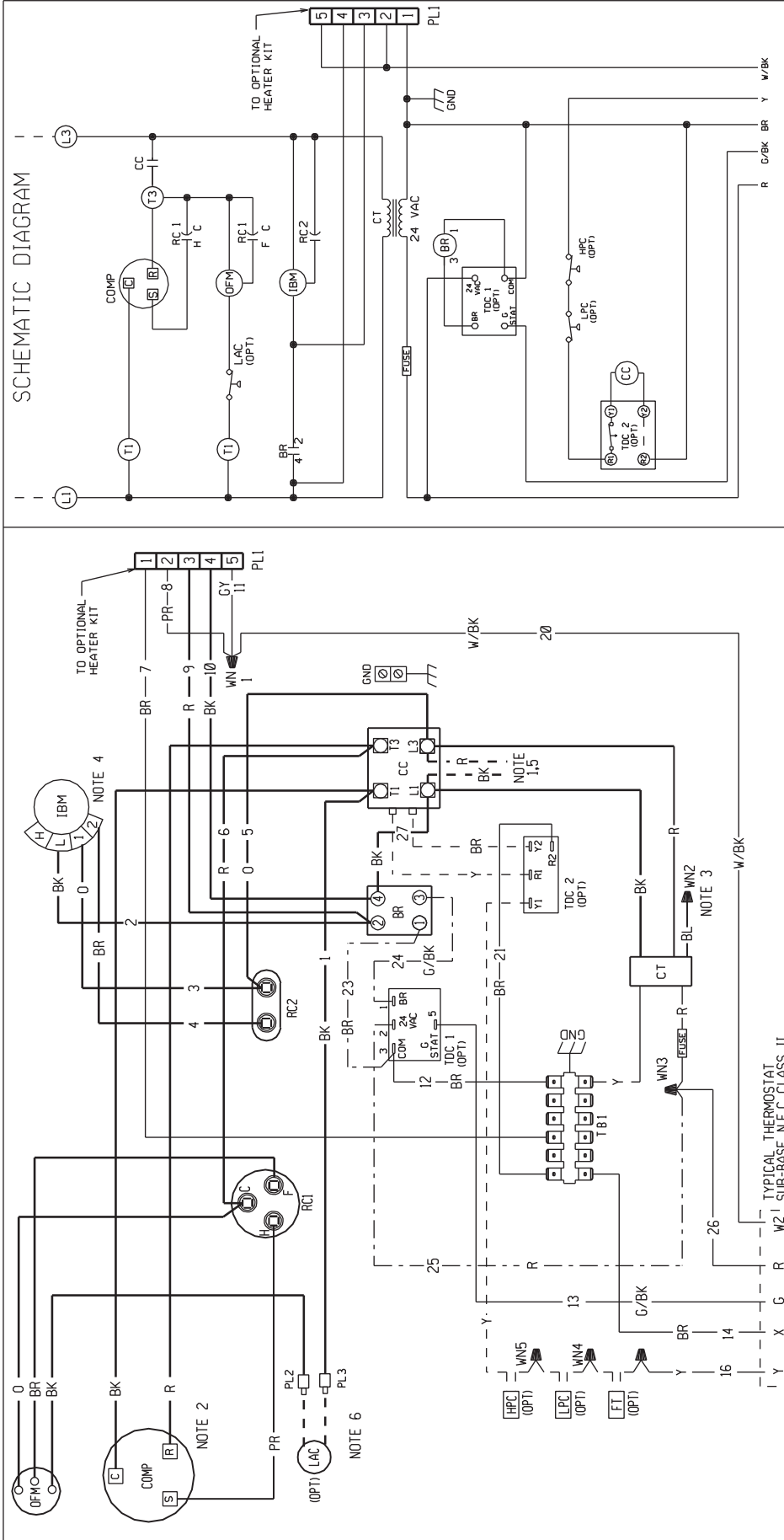

<p><b>WIRE COLOR CODE</b></p> <p>BK...BLACK          BR...BROWN          BL...BLUE          G...GREEN          GY...GRAY          O...ORANGE          PR...PURPLE          R...RED          W...WHITE          Y...YELLOW</p>	<p><b>WIRING INFORMATION</b></p> <p>LINE VOLTAGE          -FACTORY STANDARD          -FACTORY OPTION          -FIELD INSTALLED          LOW VOLTAGE          -FACTORY STANDARD          -FACTORY OPTION          -FIELD INSTALLED          REPLACEMENT WIRE          -MUST BE THE SAME SIZE AND TYPE OF INSULATION AS ORIGINAL (105 C.MIN.)          -CABINET MUST BE PERMANENTLY GROUNDED AND CONFORM TO I.E.C., N.E.C., C.E.C., NATIONAL WIRING REGULATIONS, AND LOCAL CODES AS APPLICABLE.</p>	<p><b>COMPONENT CODE</b></p> <p>BL...LOW PRESSURE CONTROL          OFM...OUTDOOR FAN MOTOR          OPT...OPTIONAL          PL...PLUG          RC...RUN CAPACITOR          TB...TERMINAL BLOCK          TDC...TIME DELAY CONTROL          W...WIRE NUT</p> <p><b>NOTES:</b></p> <p>1. CONNECTORS SUITABLE FOR USE WITH COPPER CONDUCTORS ONLY.          2. COMPRESSOR MOTOR THERMALLY PROTECTED.          3. TRANSFORMER FACTORY WIRED FOR 230 VOLTS. USE RED AND BLUE LEADS FOR 208 VOLTS.          4. MOTOR FACTORY WIRED FOR LOW SPEED. SEE AIRFLOW TABLES IN INSTALLATION INSTRUCTIONS TO DETERMINE CORRECT SPEED FOR UNIT APPLICATION.          5. FIELD WIRING OR CONNECTION FROM HEATER KIT FUSE BLOCK.          6. PL2 &amp; PL3 ARE CONNECTED WHEN LAC IS NOT PRESENT.</p>	<p><b>ELECTRICAL WIRING DIAGRAM</b></p> <p><b>PACKAGE AIR CONDITIONER</b></p> <p>1 PH, 208-230 VOLT - 60 HZ          1 PH, 220-240 VOLT - 50 HZ</p> <p>DR. BY DATE 03-09-04          B.J.L. I.D.W.G. NO. 90-23637-05          REV 04</p>
---	---	---	--

**FIGURE 8**  
**WIRING DIAGRAM - RSNM**

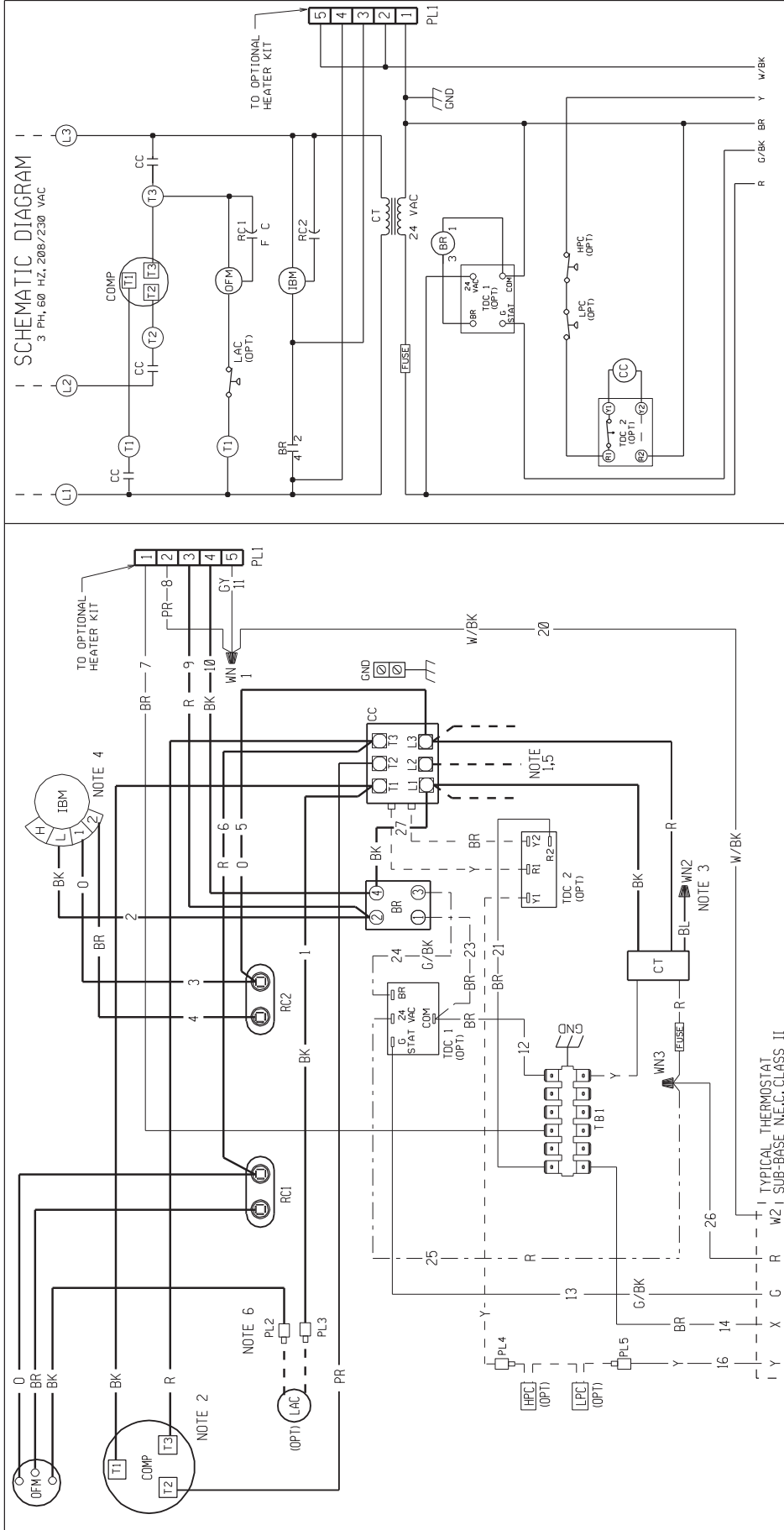

<p><b>SCHEMATIC DIAGRAM</b>          3 PH, 60 HZ, 208/230 VAC</p>	<p><b>WIRING INFORMATION</b></p> <p>LINE VOLTAGE          -FACTORY STANDARD          -FACTORY OPTION          -FIELD INSTALLED</p> <p>LOW VOLTAGE          -FACTORY STANDARD          -FACTORY OPTION          -FIELD INSTALLED</p> <p>REPLACEMENT WIRE          -MUST BE THE SAME SIZE AND TYPE OF INSULATION AS ORIGINAL (105 C MIN.)          -CABINET MUST BE PERMANENTLY GROUNDED AND CONFORM TO I.E.C., N.E.C., C.E.C. AND LOCAL CODES AS APPLICABLE.</p>	<p><b>WIRE COLOR CODE</b></p> <p>BK---BLACK          BR---BROWN          BL---BLUE          G---GREEN          GY---GRAY          O---ORANGE          PR---PURPLE          R---RED          W---WHITE          Y---YELLOW</p>	<p><b>ELECTRICAL WIRING DIAGRAM</b></p> <p><b>PACKAGE AIR CONDITIONER</b>          3 PH, 208-230 VOLT - 60 HZ</p> <p>DR. BY: APP. BY: DATE: DWG. NO. REV          KDF 06-29-04 90-23637-06 01</p>
<p><b>NOTES:</b></p> <ol style="list-style-type: none"> <li>CONNECTORS SUITABLE FOR USE WITH COPPER CONDUCTORS ONLY.</li> <li>COMPRESSOR MOTOR THERMALLY PROTECTED.</li> <li>TRANSFORMER FACTORY WIRED FOR 230 VOLTS. USE RED AND BLUE LEADS FOR 208 VOLTS.</li> <li>MOTOR FACTORY WIRED FOR LOW SPEED. SEE AIRFLOW TABLES IN INSTALLATION INSTRUCTIONS TO DETERMINE CORRECT SPEED FOR UNIT APPLICATION.</li> <li>FIELD WIRING OR CONNECTION FROM HEATER KIT</li> <li>PL2 &amp; PL3 ARE CONNECTED WHEN LAC IS NOT PRESENT.</li> </ol>	<p><b>COMPONENT CODE</b></p> <p>LAC LOW AMBIENT COOLING CONTROL          OPT OUTDOOR FAN MOTOR OPTIONAL PLUG          RC RUN CAPACITOR          TB TERMINAL BLOCK          TDC TIME DELAY CONTROL          WIRE NUT</p>	<p><b>COMPONENT CODE</b></p> <p>AUX. LIMIT CONTROL          BLOWER RELAY          COMPRESSOR CONTACTOR          CRANKCASE HEATER          COMPRESSOR          CONTROL TRANSFORMER          GND GROUND          HPC HIGH PRESSURE CONTROL          INDOOR BLOWER MOTOR</p>	<p><b>NOTES:</b></p> <p>1. CONNECTORS SUITABLE FOR USE WITH COPPER CONDUCTORS ONLY.          2. COMPRESSOR MOTOR THERMALLY PROTECTED.          3. TRANSFORMER FACTORY WIRED FOR 230 VOLTS. USE RED AND BLUE LEADS FOR 208 VOLTS.          4. MOTOR FACTORY WIRED FOR LOW SPEED. SEE AIRFLOW TABLES IN INSTALLATION INSTRUCTIONS TO DETERMINE CORRECT SPEED FOR UNIT APPLICATION.          5. FIELD WIRING OR CONNECTION FROM HEATER KIT          6. PL2 &amp; PL3 ARE CONNECTED WHEN LAC IS NOT PRESENT.</p>



**FIGURE 9**  
**WIRING DIAGRAM – RSPM – WITH X-13 BLOWER MOTOR**

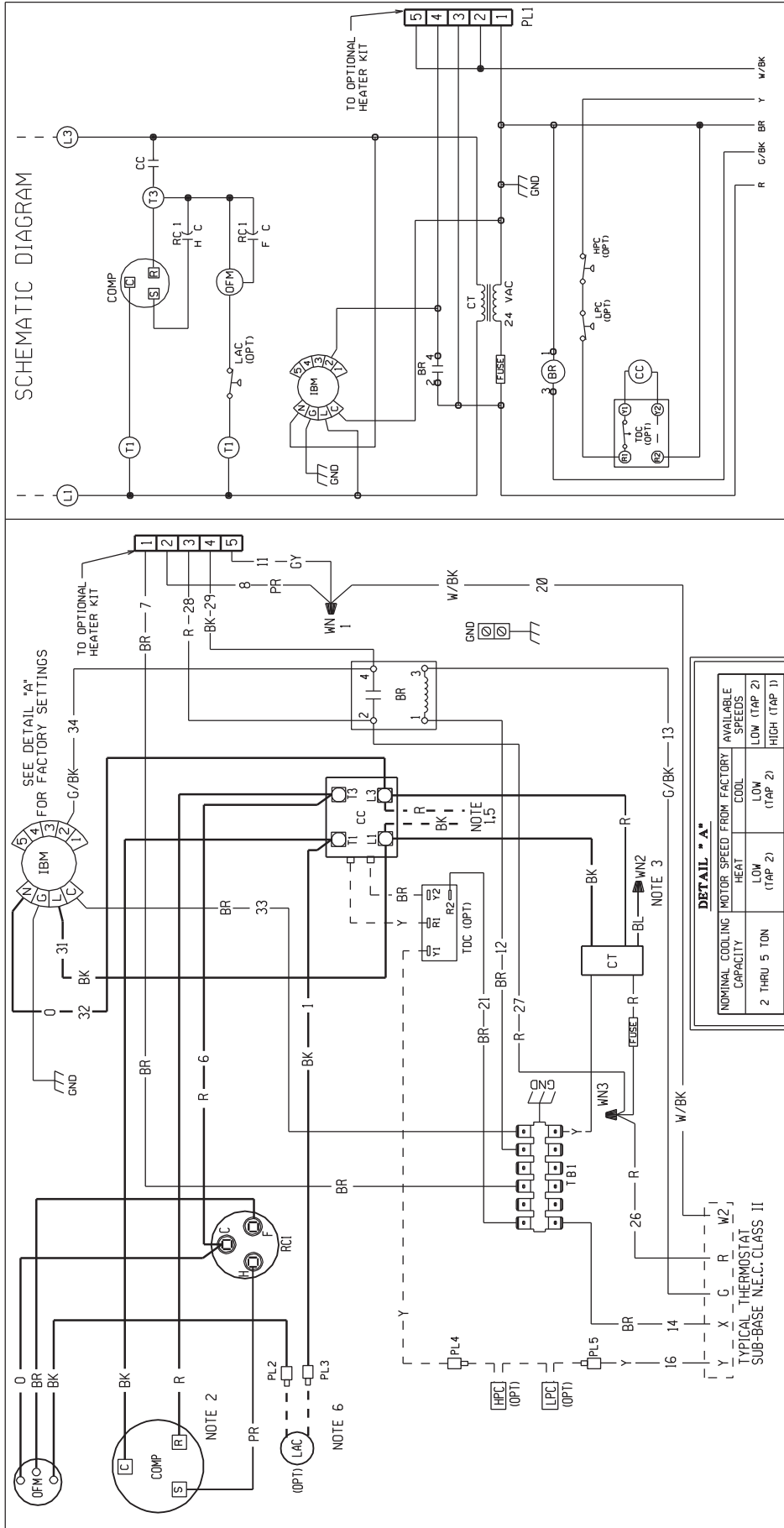

**WIRING INFORMATION**

LINE VOLTAGE  
 -FACTORY STANDARD  
 -FACTORY OPTION  
 -FIELD INSTALLED

LOW VOLTAGE  
 -FACTORY STANDARD  
 -FACTORY OPTION  
 -FIELD INSTALLED

REPLACEMENT WIRE  
 -MUST BE THE SAME SIZE AND TYPE OF INSULATION AS ORIGINAL (105 C MIN.)  
 -CABINET MUST BE PERMANENTLY GROUNDED AND CONFORM TO I.E.C., N.E.C., C.E.C. AND LOCAL CODES AS APPLICABLE.

**WIRE COLOR CODE**

BK...BLACK  
 BR...BROWN  
 BL...BLUE  
 G...GREEN

GY...GRAY  
 O...ORANGE  
 PK...PINK  
 GR...GREEN

RED  
 WHITE  
 YELLOW  
 PURPLE

**COMPONENT CODE**

ALC	AUX. LIMIT CONTROL
BR	BLOWER RELAY
CC	COMPRESSOR CONTACTOR
CCH	CRANKCASE HEATER
COMP	COMPRESSOR
CT	CONTROL TRANSFORMER
GND	GROUND
HPC	HIGH PRESSURE CONTROL
IBM	INDOOR BLOWER MOTOR
LAC	LOW AMBIENT COOLING CONTROL
OFM	OUTDOOR FAN MOTOR
OPT	OPTIONAL
PL	PLUG
RC	RUN CAPACITOR
TB	TERMINAL BLOCK
TBC	TIME DELAY CONTROL
TDC	WIRE NUT

**NOTES:**

- CONNECTORS SUITABLE FOR USE WITH COPPER CONDUCTORS ONLY.
- COMPRESSOR MOTOR THERMALLY PROTECTED.
- TRANSFORMER FACTORY WIRED FOR 230 VOLTS. USE RED AND BLUE LEADS FOR 208 VOLTS.
- MOTOR FACTORY WIRED FOR LOW SPEED. SEE AIRFLOW TABLES IN INSTALLATION INSTRUCTIONS TO DETERMINE CORRECT SPEED FOR UNIT APPLICATION.
- FIELD WIRING OR CONNECTION FROM HEATER KIT REPLACE WIRE BLOCK.
- PL2 & PL3 ARE CONNECTED WHEN LAC IS NOT PRESENT.

**DETAIL "A"**

NOMINAL COOLING CAPACITY	MOTOR SPEED	FROM FACTORY	AVAILABLE SPEEDS
2 THRU 5 TON	HEAT	LOW (TAP 2)	LOW (TAP 2)
	COOL	LOW (TAP 2)	HIGH (TAP 1)

**ELECTRICAL WIRING DIAGRAM**

**PACKAGE AIR CONDITIONER**

1 PH, 208-230 VOLT - 60 HZ

DR. BY: JRJ    APP. BY: DATE: 8-16-05    DWG. NO.: 90-23637-09    REV: 01

**FIGURE 10**  
**WIRING DIAGRAM – RSPM – WITH X-13 BLOWER MOTOR**

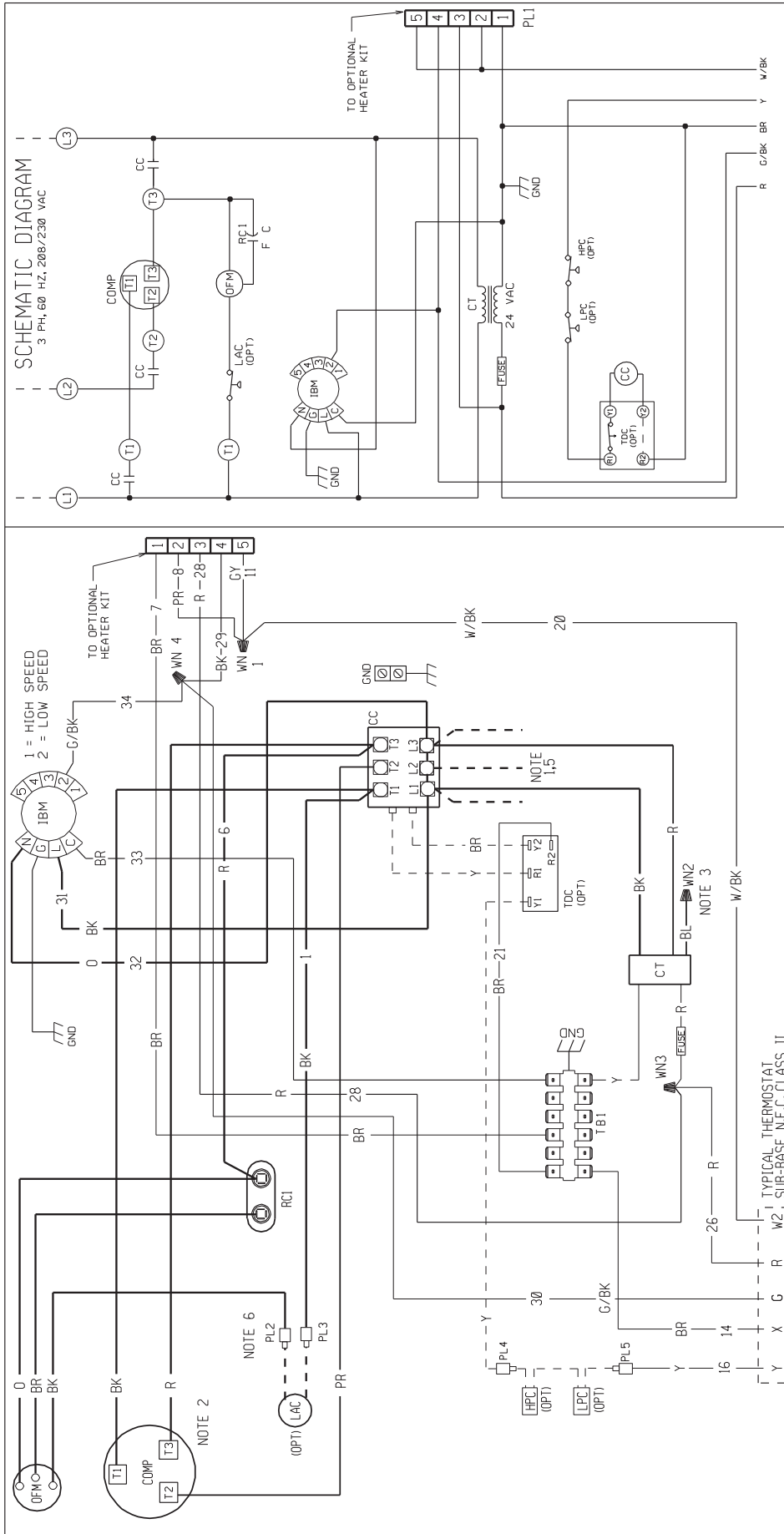

<p><b>COMPONENT CODE</b></p> <p>AUX. LIMIT CONTROL          ALR          BLOWER RELAY          BLR          COMPRESSOR CONTACTOR          CC          CRANKCASE HEATER          CCH          COMPRESSOR          CONTROL          CT          GROUND          GND          HIGH PRESSURE CONTROL          HPC          INDOOR BLOWER MOTOR          IBM</p>	<p><b>WIRING INFORMATION</b></p> <p>LINE VOLTAGE          -FACTORY STANDARD          -FACTORY OPTION          -FIELD INSTALLED</p> <p>LOW VOLTAGE          -FACTORY STANDARD          -FACTORY OPTION          -FIELD INSTALLED</p> <p>REPLACEMENT WIRE          -MUST BE THE SAME SIZE AND TYPE OF INSULATION AS ORIGINAL (105 C° MIN.)          -CABINET MUST BE PERMANENTLY GROUNDED AND CONFORM TO I.E.C., N.E.C., C.E.C. AND LOCAL CODES AS APPLICABLE.</p>	<p><b>NOTES:</b></p> <p>1. CONNECTORS SUITABLE FOR USE WITH COPPER CONDUCTORS ONLY.          2. COMPRESSOR MOTOR THERMALLY PROTECTED.          3. TRANSFORMER FACTORY WIRED FOR 230 VOLTS. USE RED AND BLUE LEADS FOR 208 VOLTS.          4. MOTOR FACTORY WIRED FOR LOW SPEED. SEE AIRFLOW TABLES IN INSTALLATION INSTRUCTIONS TO DETERMINE CORRECT SPEED FOR UNIT APPLICATION.          5. FIELD WIRING OR CONNECTION FROM HEATER KIT FUSE BLOCK.          6. PL2 &amp; PL3 ARE CONNECTED WHEN LAC IS NOT PRESENT.</p>	<p><b>WIRE COLOR CODE</b></p> <p>BK__BLACK GY__GRAY R__RED          BR__BROWN O__ORANGE W__WHITE          BL__BLUE PK__PINK Y__YELLOW          G__GREEN PR__PURPLE</p> <p><b>ELECTRICAL WIRING DIAGRAM</b></p> <p><b>PACKAGE AIR CONDITIONER</b></p> <p>3 PH, 208-230 VOLT - 60 HZ</p>
<p>DWG. NO. 90-23637-10</p>	<p>DR. BY APP. BY DATE 8-18-05</p>	<p>JRJ</p>	<p>REV 00</p>

**FIGURE 11**  
**WIRING DIAGRAM**

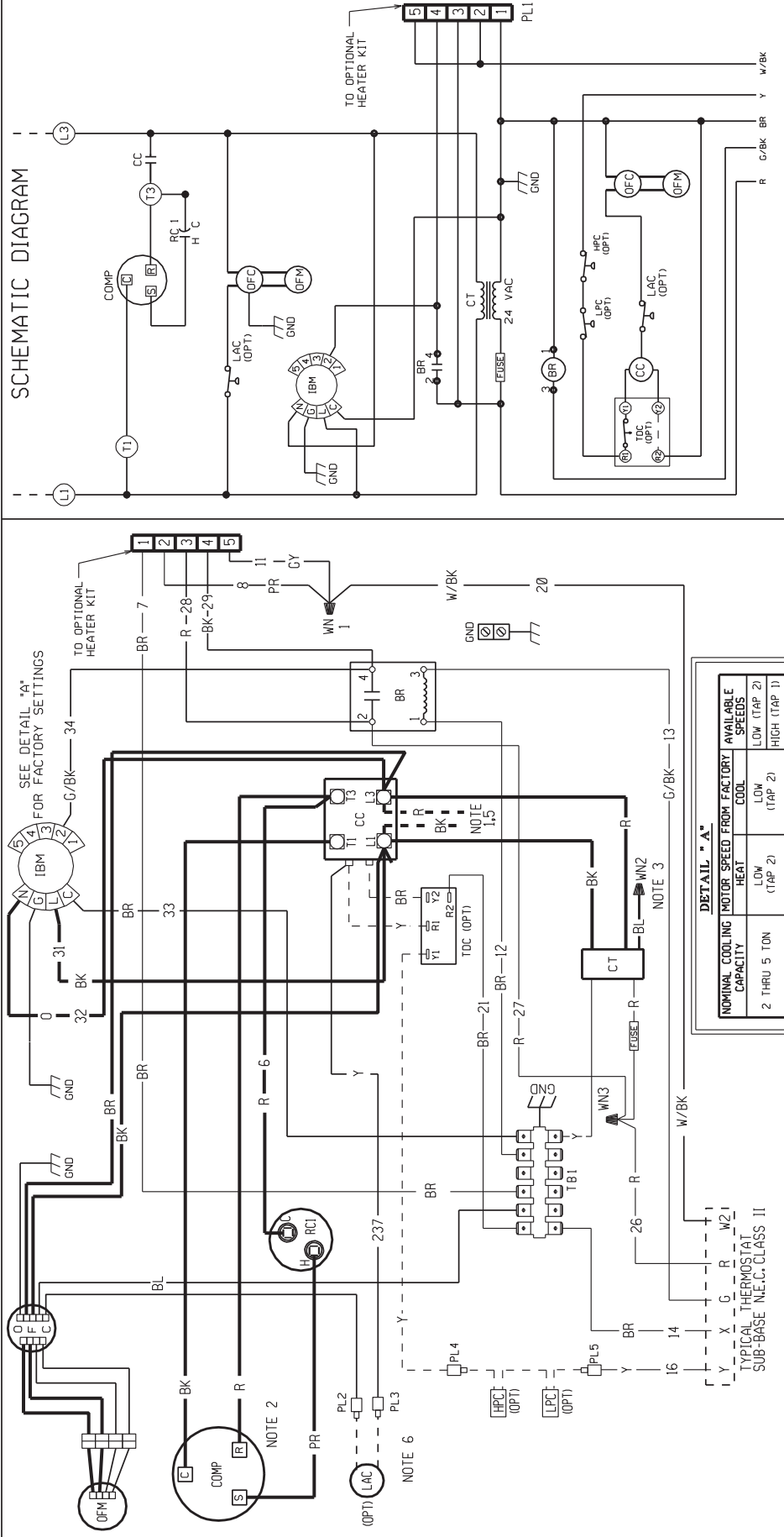

**SCHEMATIC DIAGRAM**

**WIRE COLOR CODE**

BK	BLACK	GY	GRAY	R	RED
BR	BROWN	O	ORANGE	W	WHITE
BL	BLUE	PK	PINK	Y	YELLOW
G	GREEN	PR	PURPLE	CL	CLEAR

**WIRING INFORMATION**

LINE VOLTAGE  
 -FACTORY STANDARD  
 -FACTORY OPTION  
 -FIELD INSTALLED

LOW VOLTAGE  
 -FACTORY STANDARD  
 -FACTORY OPTION  
 -FIELD INSTALLED

REPLACEMENT WIRE  
 -MUST BE THE SAME SIZE AND TYPE OF INSULATION AS ORIGINAL (105 C° MIN)

WARNING  
 -CABINET MUST BE PERMANENTLY GROUNDED AND CONFORM TO I.E.C., N.E.C., C.E.C. AND LOCAL CODES AS APPLICABLE.

**DETAIL "A"**

NOMINAL COOLING CAPACITY	MOTOR SPEED FROM FACTORY	AVAILABLE SPEEDS
2 THRU 5 TON	HEAT (TAP 2)	LOW (TAP 2)
	COOL (TAP 2)	LOW (TAP 2)
		HIGH (TAP 1)

**NOTES:**

- CONNECTORS SUITABLE FOR USE WITH COPPER CONDUCTORS ONLY.
- COMPRESSOR MOTOR THERMALLY PROTECTED.
- TRANSFORMER FACTORY WIRED FOR 230 VOLTS. USE RED AND BLUE LEADS FOR 208 VOLTS.
- MOTOR FACTORY WIRED FOR LOW SPEED. SEE AIRFLOW TABLES IN INSTALLATION INSTRUCTIONS TO DETERMINE CORRECT SPEED FOR UNIT APPLICATION.
- FIELD WIRING OR CONNECTION FROM HEATER KIT FUSE BLOCK.
- PL2 & PL3 ARE CONNECTED WHEN LAC IS NOT PRESENT.

**COMPONENT CODE**

LAC LOW AMBIENT COOLING CONTROL  
 BL BLOWER RELAY  
 CC COMPRESSOR CONTACTOR  
 CCH CRANKCASE HEATER  
 COMP COMPRESSOR  
 CT CONTROL TRANSFORMER  
 GND GROUND  
 HPC HIGH PRESSURE CONTROL  
 IBM INDOOR BLOWER MOTOR

**WIRING INFORMATION**

REPLACEMENT WIRE  
 -MUST BE THE SAME SIZE AND TYPE OF INSULATION AS ORIGINAL (105 C° MIN)

WARNING  
 -CABINET MUST BE PERMANENTLY GROUNDED AND CONFORM TO I.E.C., N.E.C., C.E.C. AND LOCAL CODES AS APPLICABLE.

**SCHEMATIC DIAGRAM**

**WIRE COLOR CODE**

BK	BLACK	GY	GRAY	R	RED
BR	BROWN	O	ORANGE	W	WHITE
BL	BLUE	PK	PINK	Y	YELLOW
G	GREEN	PR	PURPLE	CL	CLEAR

**WIRING INFORMATION**

LINE VOLTAGE  
 -FACTORY STANDARD  
 -FACTORY OPTION  
 -FIELD INSTALLED

LOW VOLTAGE  
 -FACTORY STANDARD  
 -FACTORY OPTION  
 -FIELD INSTALLED

REPLACEMENT WIRE  
 -MUST BE THE SAME SIZE AND TYPE OF INSULATION AS ORIGINAL (105 C° MIN)

WARNING  
 -CABINET MUST BE PERMANENTLY GROUNDED AND CONFORM TO I.E.C., N.E.C., C.E.C. AND LOCAL CODES AS APPLICABLE.

**DETAIL "A"**

NOMINAL COOLING CAPACITY	MOTOR SPEED FROM FACTORY	AVAILABLE SPEEDS
2 THRU 5 TON	HEAT (TAP 2)	LOW (TAP 2)
	COOL (TAP 2)	LOW (TAP 2)
		HIGH (TAP 1)

**NOTES:**

- CONNECTORS SUITABLE FOR USE WITH COPPER CONDUCTORS ONLY.
- COMPRESSOR MOTOR THERMALLY PROTECTED.
- TRANSFORMER FACTORY WIRED FOR 230 VOLTS. USE RED AND BLUE LEADS FOR 208 VOLTS.
- MOTOR FACTORY WIRED FOR LOW SPEED. SEE AIRFLOW TABLES IN INSTALLATION INSTRUCTIONS TO DETERMINE CORRECT SPEED FOR UNIT APPLICATION.
- FIELD WIRING OR CONNECTION FROM HEATER KIT FUSE BLOCK.
- PL2 & PL3 ARE CONNECTED WHEN LAC IS NOT PRESENT.

**COMPONENT CODE**

LAC LOW AMBIENT COOLING CONTROL  
 BL BLOWER RELAY  
 CC COMPRESSOR CONTACTOR  
 CCH CRANKCASE HEATER  
 COMP COMPRESSOR  
 CT CONTROL TRANSFORMER  
 GND GROUND  
 HPC HIGH PRESSURE CONTROL  
 IBM INDOOR BLOWER MOTOR

**WIRING INFORMATION**

REPLACEMENT WIRE  
 -MUST BE THE SAME SIZE AND TYPE OF INSULATION AS ORIGINAL (105 C° MIN)

WARNING  
 -CABINET MUST BE PERMANENTLY GROUNDED AND CONFORM TO I.E.C., N.E.C., C.E.C. AND LOCAL CODES AS APPLICABLE.

**FIGURE 12**  
**WIRING DIAGRAM**

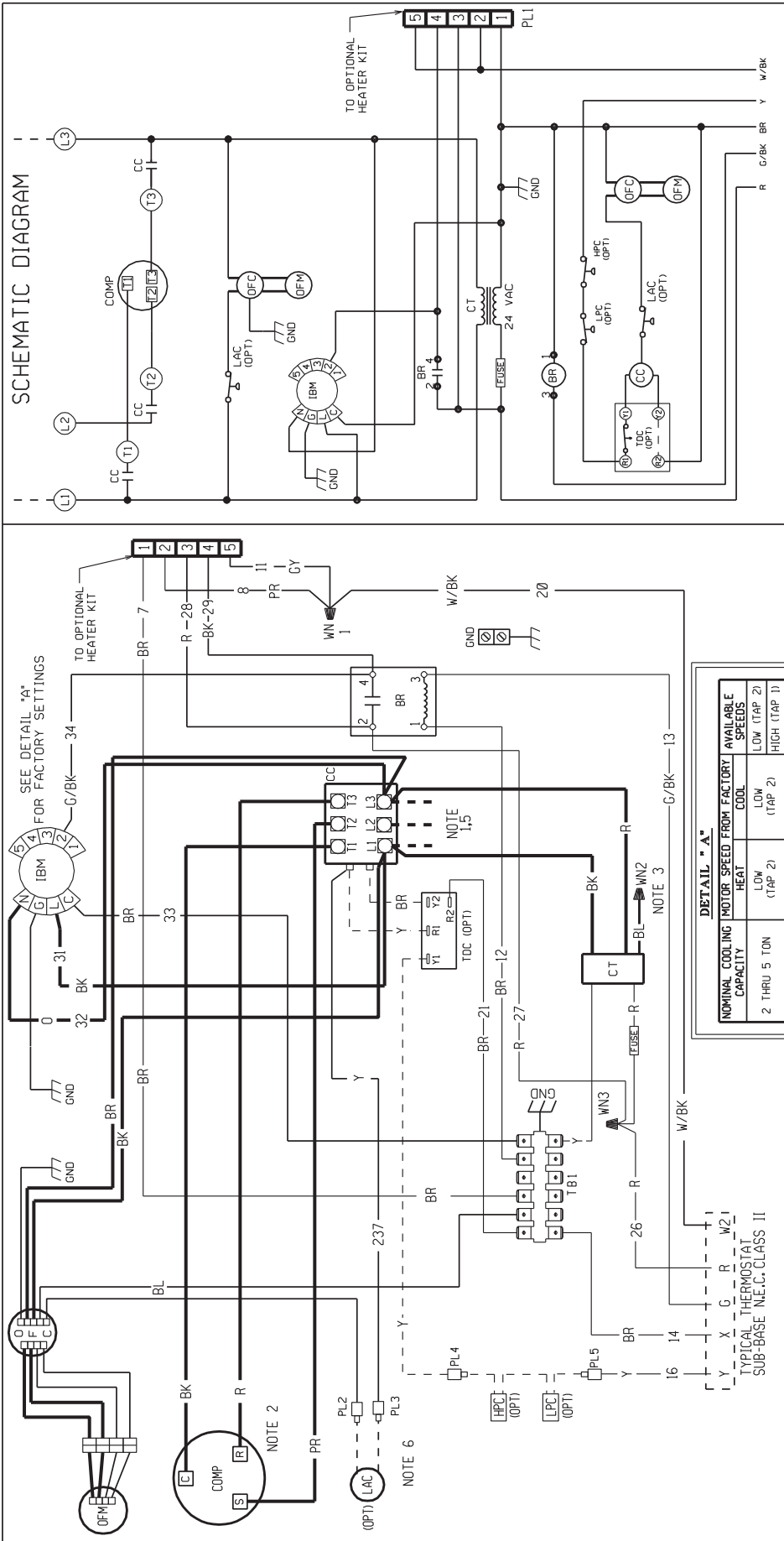

**SCHEMATIC DIAGRAM**

**WIRING INFORMATION**

**COMPONENT CODE**

**WIRE COLOR CODE**

**ELECTRICAL WIRING DIAGRAM**

**PACKAGE AIR CONDITIONER**

**WITH INDOOR X-MOTOR AND OUTDOOR REMOTE CONTROL ECM**

3 PH, 208-230 VOLT - 60 HZ

DR. BY: JHB    APP. BY: DATE: 9-03-09    DWG. NO. 90-23637-18    REV 01

**NOTES:**

- CONNECTORS SUITABLE FOR USE WITH COPPER CONDUCTORS ONLY.
- COMPRESSOR MOTOR THERMALLY PROTECTED.
- TRANSFORMER FACTORY WIRED FOR 230 VOLTS. USE RED AND BLUE LEADS FOR 208 VOLTS.
- MOTOR FACTORY WIRED FOR LOW SPEED. SEE AIRFLOW TABLES IN INSTALLATION INSTRUCTIONS TO DETERMINE CORRECT SPEED FOR UNIT APPLICATION.
- FIELD WIRING OR CONNECTION FROM HEATER KIT FUSE BLOCK.
- PL2 & PL3 ARE CONNECTED WHEN LAC IS NOT PRESENT.

**COMPONENT CODE**

LAC LOW AMBIENT COOLING CONTROL  
 BL BLOWER RELAY  
 CC COMPRESSOR CONTACTOR  
 CCH CRANKCASE HEATER  
 COMP COMPRESSOR  
 CT CONTROL TRANSFORMER  
 GND GROUND  
 HPC HIGH PRESSURE CONTROL  
 IBM INDOOR BLOWER MOTOR

**WIRE COLOR CODE**

BK BLACK    GY GRAY    R RED  
 BR BROWN    O ORANGE    W WHITE  
 BL BLUE    PK PINK    Y YELLOW  
 G GREEN    PR PURPLE    CL CLEAR

**WIRING INFORMATION**

LINE VOLTAGE  
 -FACTORY STANDARD  
 -FACTORY OPTION  
 -FIELD INSTALLED

LOW VOLTAGE  
 -FACTORY STANDARD  
 -FACTORY OPTION  
 -FIELD INSTALLED

REPLACEMENT WIRE  
 -MUST BE THE SAME SIZE AND TYPE OF INSULATION AS ORIGINAL (105 C° MIN.)  
 -CABINET MUST BE PERMANENTLY GROUNDED AND CONFORM TO I.E.C., N.E.C., C.E.C. AND LOCAL CODES AS APPLICABLE.

**FIGURE 13**  
2 TON AIR CHARGING CHART

**2 TON COOLING - 13 AND 14 SEER  
SYSTEM CHARGE CHART - REFRIGERANT 410A**

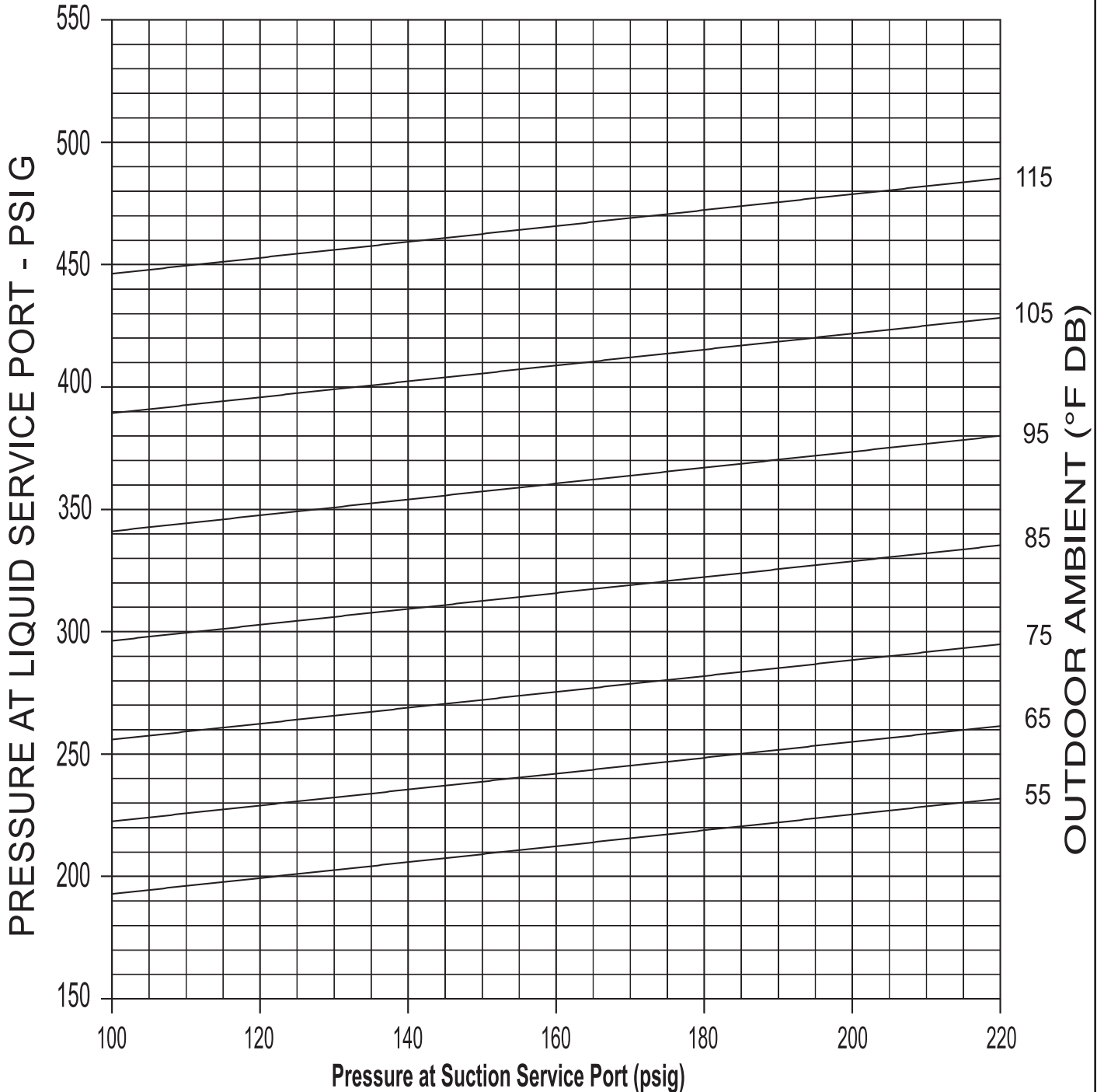

**CAUTION:** BEFORE FINAL REFRIGERANT CHECK, INDOOR RETURN AIR TEMPERATURE SHOULD BE AT COMF ORT CONDITIONS FOR MOST ACCURATE RESULTS.

**INSTRUCTIONS:**

1. CONNECT PRESSURE GAUGES TO SUCTION AND LIQUID PORTS ON UNIT.
2. MEASURE AIR TEMPERATURE TO OUTDOOR COIL.
3. PLACE AN "X" ON THE APPROPRIATE CHART WHERE THE SUCTION AND LIQUID PRESSURES CR OSS.
4. IF "X" IS BELOW AMBIENT TEMPERATURE LINE, ADD CHARGE AND REPEAT STEP 3.
5. IF "X" IS ABOVE AMBIENT TEMPERATURE LINE, RECOVER EXCESS CHARGE AND REPEAT STEP 3.

92 - 102337 - 01 - 00

**FIGURE 14**  
2.5 TON AIR CHARGING CHART

**2 1/2 TON COOLING - 13 AND 14 SEER  
SYSTEM CHARGE CHART - REFRIGERANT 410A**

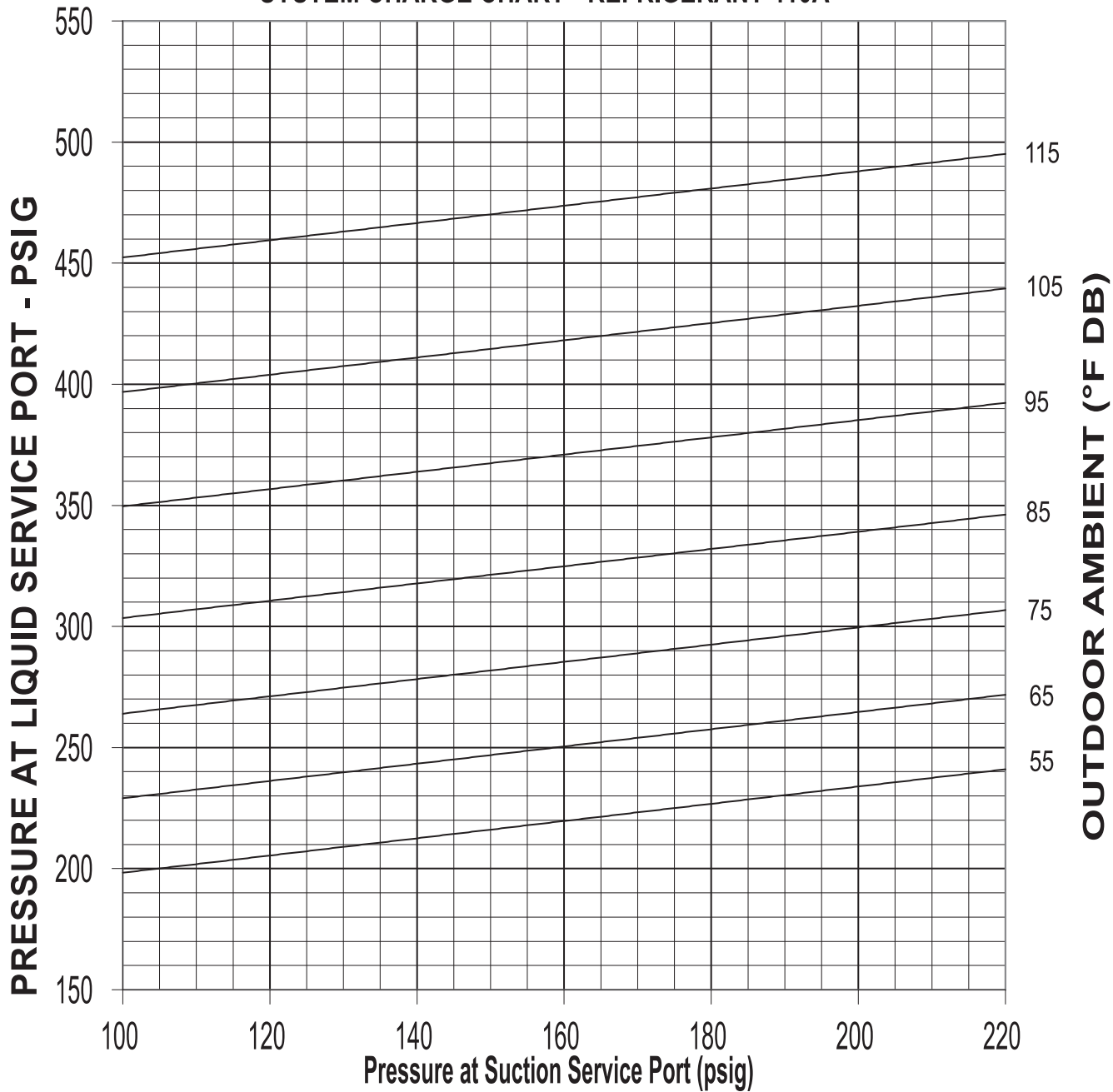

**CAUTION:** BEFORE FINAL REFRIGERANT CHECK, INDOOR RETURN AIR TEMPERATURE SHOULD BE AT COMF ORT CONDITIONS FOR MOST ACCURATE RESULTS.

**INSTRUCTIONS:**

1. CONNECT PRESSURE GAUGES TO SUCTION AND LIQUID PORTS ON UNIT.
2. MEASURE AIR TEMPERATURE TO OUTDOOR COIL.
3. PLACE AN "X" ON THE APPROPRIATE CHART WHERE THE SUCTION AND LIQUID PRESSURES CR OSS.
4. IF "X" IS BELOW AMBIENT TEMPERATURE LINE, ADD CHARGE AND REPEAT STEP 3.
5. IF "X" IS ABOVE AMBIENT TEMPERATURE LINE, RECOVER EXCESS CHARGE AND REPEAT STEP 3.

92-102337-02-00

**FIGURE 15**  
3.0 TON CHARGING CHART

**3 TON COOLING - 13 AND 14 SEER  
SYSTEM CHARGE CHART - REFRIGERANT 410A**

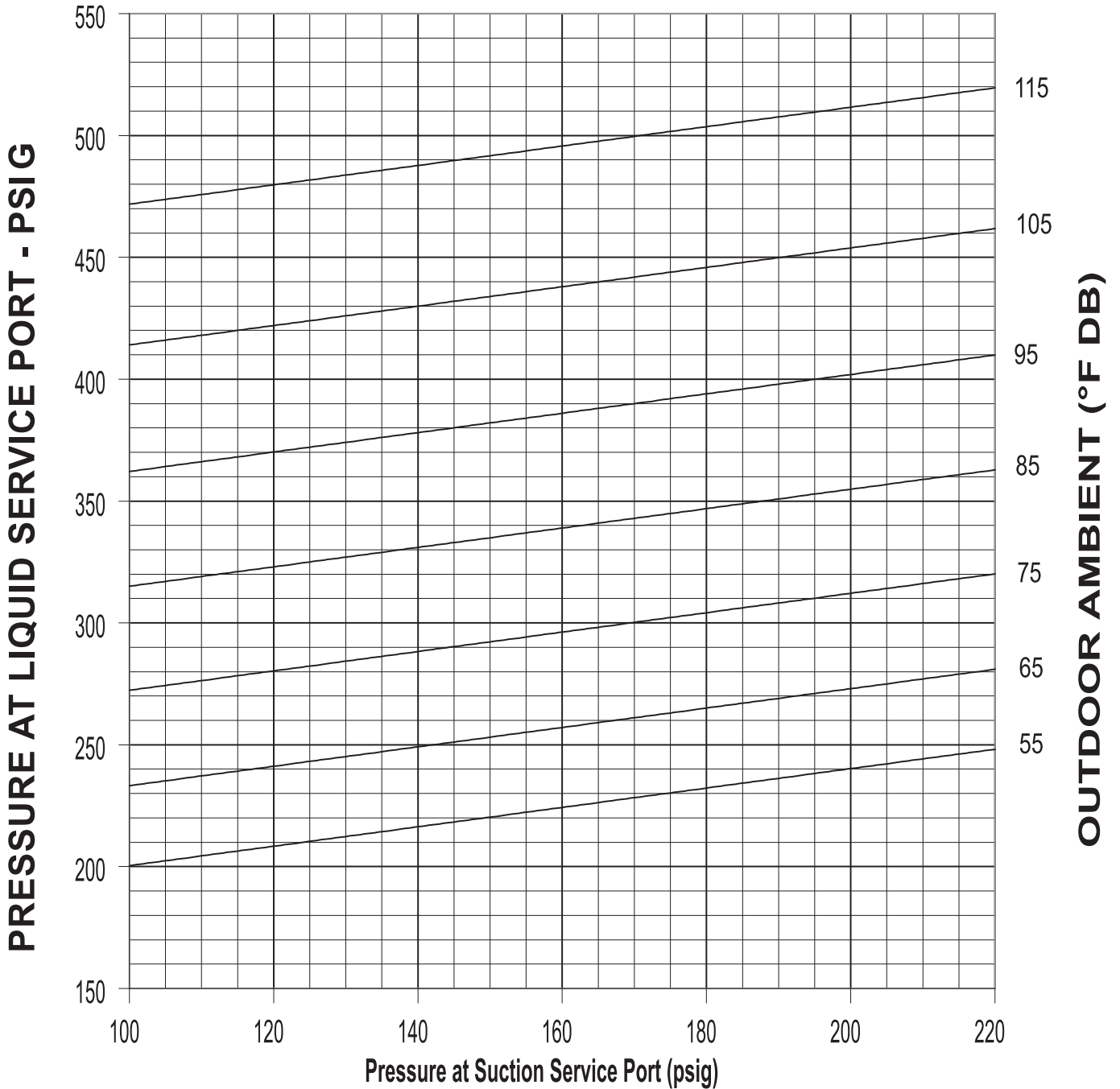

**CAUTION:** BEFORE FINAL REFRIGERANT CHECK, INDOOR RETURN AIR TEMPERATURE SHOULD BE AT COMF ORT CONDITIONS FOR MOST ACCURATE RESULTS .

**INSTRUCTIONS:**

1. CONNECT PRESSURE GAUGES TO SUCTION AND LIQUID PORTS ON UNIT .
2. MEASURE AIR TEMPERATURE TO OUTDOOR COIL .
3. PLACE AN "X" ON THE APPROPRIATE CHART WHERE THE SUCTION AND LIQUID PRESSURES CROSS .
4. IF "X" IS BELOW AMBIENT TEMPERATURE LINE, ADD CHARGE AND REPEAT STEP 3 .
5. IF "X" IS ABOVE AMBIENT TEMPERATURE LINE, RECOVER EXCESS CHARGE AND REPEAT STEP 3 .

92-102337-03-00

**FIGURE 16**  
3.5 TON CHARGING CHART

**3 1/2 TON COOLING - 13 AND 14 SEER  
SYSTEM CHARGE CHART - REFRIGERANT 410A**

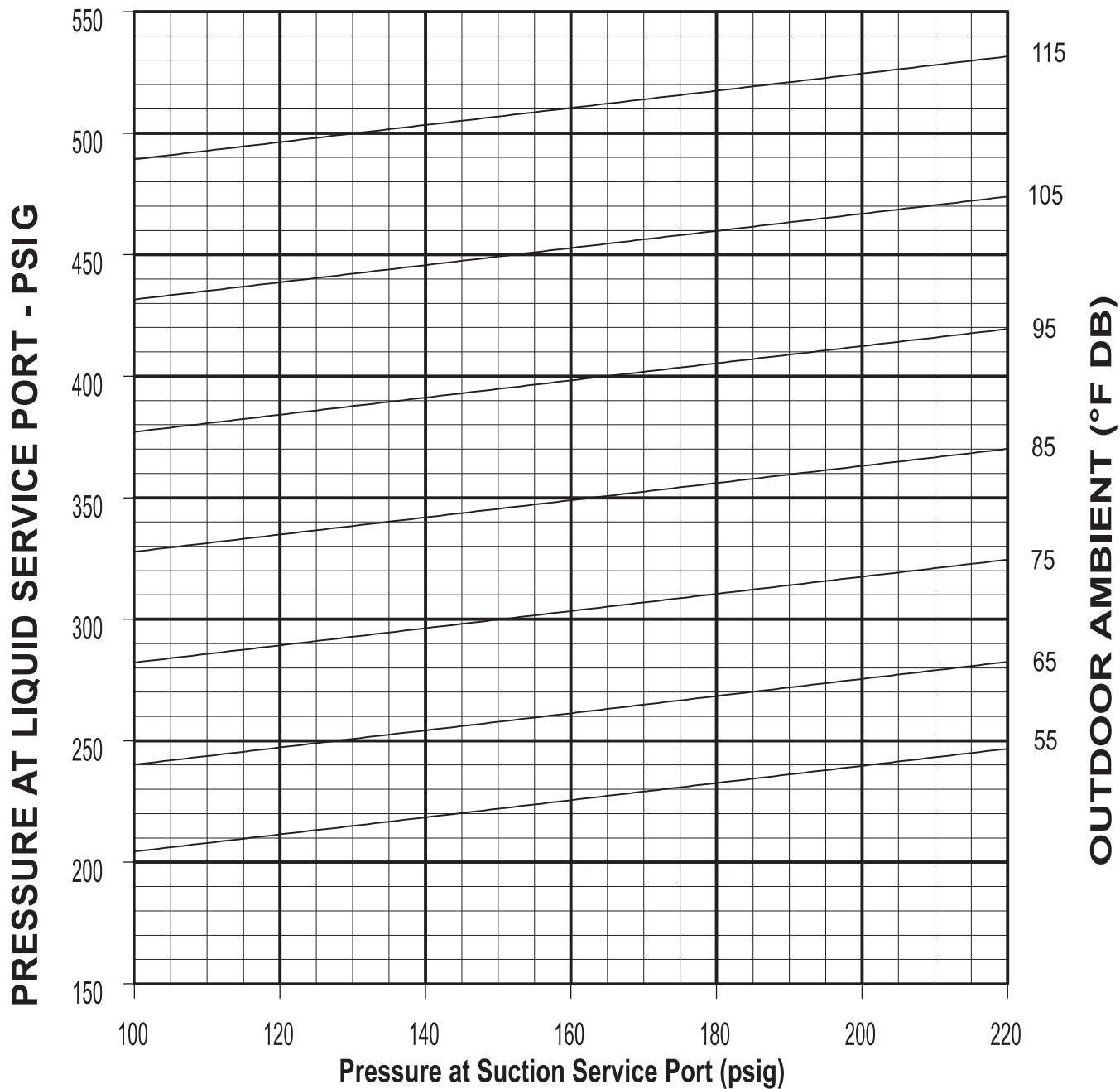

**CAUTION:** BEFORE FINAL REFRIGERANT CHECK, INDOOR RETURN AIR TEMPERATURE SHOULD BE AT COMF ORT CONDITIONS FOR MOST ACCURATE RESULTS.

**INSTRUCTIONS:**

1. CONNECT PRESSURE GAUGES TO SUCTION AND LIQUID PORTS ON UNIT.
2. MEASURE AIR TEMPERATURE TO OUTDOOR COIL.
3. PLACE AN "X" ON THE APPROPRIATE CHART WHERE THE SUCTION AND LIQUID PRESSURES CROSS.
4. IF "X" IS BELOW AMBIENT TEMPERATURE LINE, ADD CHARGE AND REPEAT STEP 3.
5. IF "X" IS ABOVE AMBIENT TEMPERATURE LINE, RECOVER EXCESS CHARGE AND REPEAT STEP 3.

92-102337-04-00



**FIGURE 17**  
4.0 TON CHARGING CHART

**4 TON COOLING - 13 AND 14 SEER  
SYSTEM CHARGE CHART - REFRIGERANT 410A**

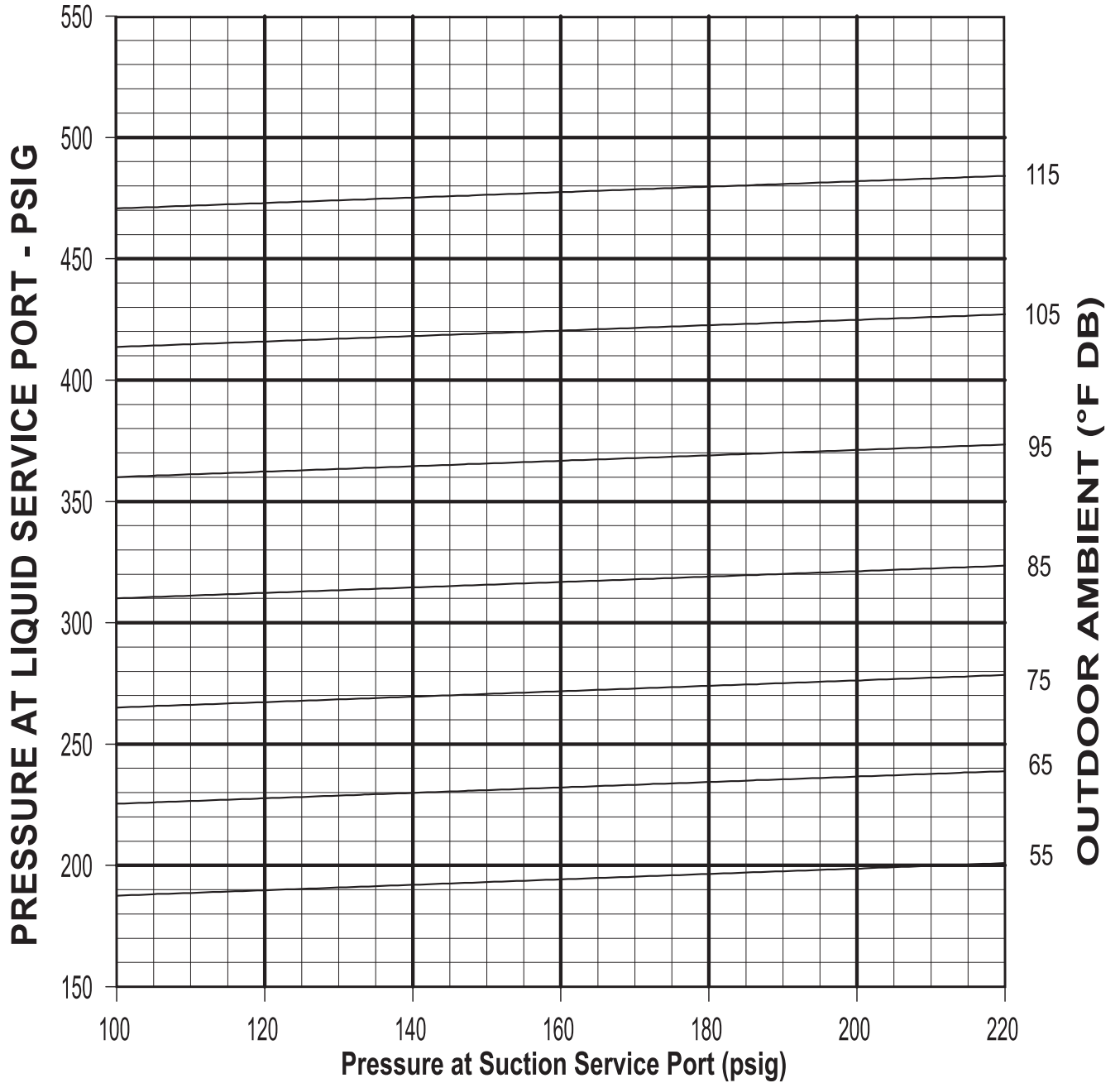

**CAUTION:** BEFORE FINAL REFRIGERANT CHECK, INDOOR RETURN AIR TEMPERATURE SHOULD BE AT COMF ORT CONDITIONS FOR MOST ACCURATE RESULTS .

**INSTRUCTIONS:**

1. CONNECT PRESSURE GAUGES TO SUCTION AND LIQUID PORTS ON UNIT .
2. MEASURE AIR TEMPERATURE TO OUTDOOR COIL .
3. PLACE AN "X" ON THE APPROPRIATE CHART WHERE THE SUCTION AND LIQUID PRESSURES CR OSS .
4. IF "X" IS BELOW AMBIENT TEMPERATURE LINE, ADD CHARGE AND REPEAT STEP 3 .
5. IF "X" IS ABOVE AMBIENT TEMPERATURE LINE, RECOVER EXCESS CHARGE AND REPEAT STEP 3 .

92-102337-05-00

**FIGURE 18**  
5.0 TON CHARGING CHART

**5 TON COOLING - 13 AND 14 SEER  
SYSTEM CHARGE CHART - REFRIGERANT 410A**

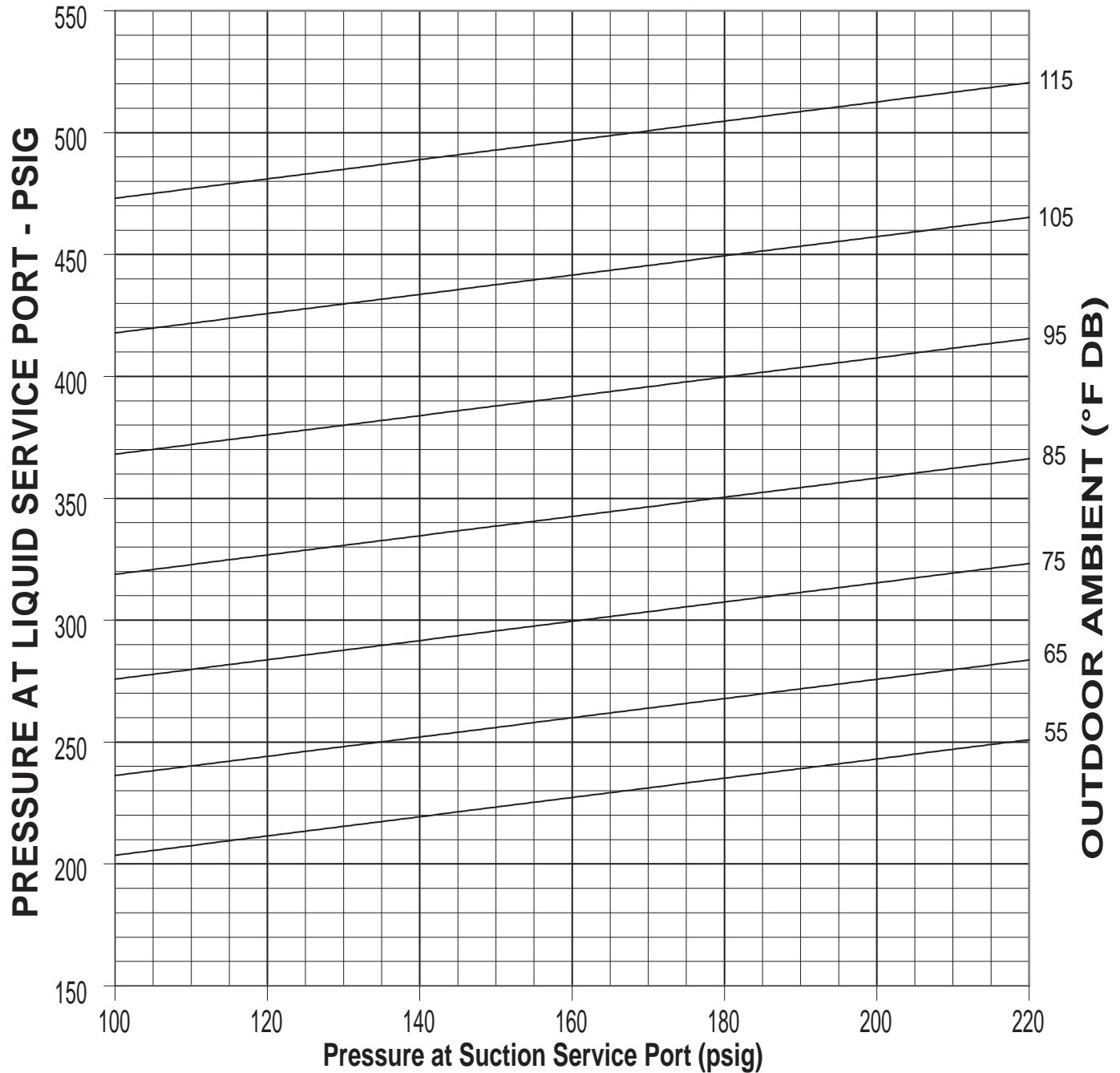

**CAUTION:** BEFORE FINAL REFRIGERANT CHECK, INDOOR RETURN AIR TEMPERATURE SHOULD BE AT COMF ORT CONDITIONS FOR MOST ACCURATE RESULTS .

**INSTRUCTIONS:**

1. CONNECT PRESSURE GAUGES TO SUCTION AND LIQUID PORTS ON UNIT.
2. MEASURE AIR TEMPERATURE TO OUTDOOR COIL.
3. PLACE AN "X" ON THE APPROPRIATE CHART WHERE THE SUCTION AND LIQUID PRESSURES CROSS.
4. IF "X" IS BELOW AMBIENT TEMPERATURE LINE, ADD CHARGE AND REPEAT STEP 3 .
5. IF "X" IS ABOVE AMBIENT TEMPERATURE LINE, RECOVER EXCESS CHARGE AND REPEAT STEP 3.

92-102337-06 -00

# TROUBLE SHOOTING CHART

**▲ WARNING**

**DISCONNECT ALL POWER TO UNIT BEFORE SERVICING. CONTACTOR MAY BREAK ONLY ONE SIDE. FAILURE TO SHUT OFF POWER CAN CAUSE ELECTRICAL SHOCK RESULTING IN PERSONAL INJURY OR DEATH.**

SYMPTOM	POSSIBLE CAUSE	REMEDY
Unit will not run	<ul style="list-style-type: none"> <li>• Power off or loose electrical connection</li> <li>• Thermostat out of calibration-set too high</li> <li>• Defective contactor</li> <li>• Blown fuses</li> <li>• Transformer defective</li> <li>• High pressure control open (if provided)</li> <li>• Interconnecting low voltage wiring damaged</li> </ul>	<ul style="list-style-type: none"> <li>• Check for correct voltage at compressor contactor in control box</li> <li>• Reset</li> <li>• Check for 24 volts at contactor coil - replace if contacts are open</li> <li>• Replace fuses</li> <li>• Check wiring-replace transformer</li> <li>• Reset-also see high head pressure remedy-The high pressure control opens at 450 PSIG</li> <li>• Replace thermostat wiring</li> </ul>
Condenser fan runs, compressor doesn't	<ul style="list-style-type: none"> <li>• Run or start capacitor defective (single phase only)</li> <li>• Start relay defective (single phase only)</li> <li>• Loose connection</li> <li>• Compressor stuck, grounded or open motor winding, open internal overload.</li> <li>• Low voltage condition</li> <li>• Low voltage condition</li> </ul>	<ul style="list-style-type: none"> <li>• Replace</li> <li>• Replace</li> <li>• Check for correct voltage at compressor - check &amp; tighten all connections</li> <li>• Wait at least 2 hours for overload to reset. If still open, replace the compressor. At compressor terminals, voltage must be within 10% of rating plate volts when unit is operating.</li> <li>• Add start kit components</li> </ul>
Insufficient cooling	<ul style="list-style-type: none"> <li>• Improperly sized unit</li> <li>• Improper airflow</li> <li>• Incorrect refrigerant charge</li> <li>• Air, non-condensibles or moisture in system</li> <li>• Incorrect voltage</li> </ul>	<ul style="list-style-type: none"> <li>• Recalculate load</li> <li>• Check - should be approximately 400 CFM per ton.</li> <li>• Charge per procedure attached to unit service panel</li> <li>• Recover refrigerant, evacuate &amp; recharge, add filter drier</li> <li>• At compressor terminals, voltage must be within 10% of rating plate volts when unit is operating.</li> </ul>
Compressor short cycles	<ul style="list-style-type: none"> <li>• Incorrect voltage</li> <li>• Defective overload protector</li> <li>• Refrigerant undercharge</li> </ul>	<ul style="list-style-type: none"> <li>• At compressor terminals, voltage must be <math>\pm 10\%</math> of nameplate marking when unit is operating.</li> <li>• Replace - check for correct voltage</li> <li>• Add refrigerant</li> </ul>
Registers sweat	<ul style="list-style-type: none"> <li>• Low evaporator airflow</li> </ul>	<ul style="list-style-type: none"> <li>• Increase speed of blower or reduce restriction - replace air filter</li> </ul>
High head-low vapor pressures	<ul style="list-style-type: none"> <li>• Restriction in liquid line, expansion device or filter drier</li> <li>• Flow check piston size too small</li> <li>• Incorrect capillary tubes</li> <li>• TXV does not open</li> </ul>	<ul style="list-style-type: none"> <li>• Remove or replace defective component</li> <li>• Change to correct size piston</li> <li>• Change coil assembly</li> <li>• Replace TXV</li> </ul>
High head-high or normal vapor pressure - Cooling mode	<ul style="list-style-type: none"> <li>• Dirty condenser coil</li> <li>• Refrigerant overcharge</li> <li>• Condenser fan not running</li> <li>• Air or non-condensibles in system</li> </ul>	<ul style="list-style-type: none"> <li>• Clean coil</li> <li>• Correct system charge</li> <li>• Repair or replace</li> <li>• Recover refrigerant, evacuate &amp; recharge</li> </ul>
High head-high or normal vapor pressure - Heating mode	<ul style="list-style-type: none"> <li>• Low air flow - condenser coil</li> <li>• Refrigerant overcharge</li> <li>• Air or non-condensibles in system</li> <li>• Dirty condenser coil</li> </ul>	<ul style="list-style-type: none"> <li>• Check filters - correct to speed</li> <li>• Correct system charge</li> <li>• Recover refrigerant, evacuate &amp; recharge</li> <li>• Check filter - clean coil</li> </ul>
Low head-high vapor pressures	<ul style="list-style-type: none"> <li>• Flow check piston size too large</li> <li>• Defective Compressor valves</li> <li>• Incorrect capillary tubes</li> </ul>	<ul style="list-style-type: none"> <li>• Change to correct size piston</li> <li>• Replace compressor</li> <li>• Replace coil assembly</li> </ul>
Low vapor - cool compressor - iced evaporator coil	<ul style="list-style-type: none"> <li>• Low evaporator airflow</li> <li>• Operating below 65°F outdoors</li> <li>• Moisture in system</li> <li>• TXV limiting refrigerant flow</li> </ul>	<ul style="list-style-type: none"> <li>• Increase speed of blower or reduce restriction - replace air filter</li> <li>• Add Low Ambient Kit</li> <li>• Recover refrigerant - evacuate &amp; recharge - add filter drier</li> <li>• Replace TXV</li> </ul>
High vapor pressure	<ul style="list-style-type: none"> <li>• Excessive load</li> <li>• Defective compressor</li> </ul>	<ul style="list-style-type: none"> <li>• Recheck load calculation</li> <li>• Replace</li> </ul>
Fluctuating head & vapor pressures	<ul style="list-style-type: none"> <li>• TXV hunting</li> <li>• Air or non-condensate in system</li> </ul>	<ul style="list-style-type: none"> <li>• Check TXV bulb clamp - check air distribution on coil - replace TXV</li> <li>• Recover refrigerant, evacuate &amp; recharge</li> </ul>
Gurgle or pulsing noise at expansion device or liquid line	<ul style="list-style-type: none"> <li>• Air or non-condensibles in system</li> </ul>	<ul style="list-style-type: none"> <li>• Recover refrigerant, evacuate &amp; recharge</li> </ul>

