

Accessories Economizers

AXRD-01RECBM3

Parts List
23-April-2019



*This parts list is current as of the above revision date.
See <http://www.rheempartslists.net/92-42801-AXRD-01RECBM3.pdf> for the current revision.*

No.	Notes	Part Description	Part No.
1		(3) Damper Blade with Seals - 18.938, See Note 2	N/A
2		(1) Damper Blade with Seals - 18.938, See Note 2	N/A
3		Barometric Relief Assembly	PD955606
4		Wiring Harness Kit	PD955607
5		Actuator Shaft Pin (3/8 in. x 3/8 in. x 4 1/8 in. long)	PD955608
6		OA Enthalpy Sensor (supplied with economizer)	PD955609
7		Jade Actuator: 44 in-lb. output, Spring Return, SY LK bus input signal, 24VAC power	PD955610
8		Jade Economizer Logic Module w/Heat Pump Input	PD955611
9		Discharge Air Sensor	PD955612
		Dual Enthalpy Upgrade Kit w/Literature	PD955613
11		(1) Permanent Filters (15.500 in. X 21.375 in.)	PD955423
12		(1) BR Rainhood - Bird Screen	PD955615H
13		(2) OA Rainhood - Filter Retainer	PD955616
14		(2) BR Rainhood - Bird Screen Retainer	PD955617
15		(1) OA Rainhood - Top	PD955618H
16		(1) BR Rainhood Assembly - Top	PD955619H
17		OA Rainhood Assembly - Hood Sides (1) Right Side (1) Left Side	PD955620H
18		BR Rainhood Assembly - Hood Sides (1) Right Side (1) Left Side	PD955621H
19		(1) OA Rainhood Assembly - Bottom	PD955622H
20		(1) BR Rainhood Assembly - Bottom	PD955623H
21		(1) OA Rainhood - Filter access	PD955624H
22		(1) Hood Extension - Top	PD955625H
23		(1) Hood Extension - Divider	PD955626
24		(1) Hood Extension - Bottom	PD955627H
25		(2) Hood Extension - Sides (1)Right Side (1) Left Side	PD955628H
		Hardware Bag - I & O Manual, Wire Ties, Screws	PD955629
26		(Optional) Field Installed Wall Mounted CO2 sensor with 2-10 VDC input	47-42565-02
		Adapter Harness - 9 & 2 pin to 12 pin	PD955630
27		Smoke Detector Flex Model	PD955631
		Vertical Rainhood Kit	PD955632H
		Gear Pivot	644032
		Damper Blade Control Gear (15 teeth)	PD955281
		Gear Rack (20 teeth, 10-1/2 in. long) - See Note below.	PD955282
		Note: It will be necessary to assemble as many of these 10-1/2 inch long gear racks as required to approximate the length of the assembly being replaced, and then cut the newly assembled gear rack to the desired final length. The individual gear racks are fastened to each other by using a hand punch to peen the head of the retaining stud included with each gear rack.	

No.	Notes	Part Description	Part No.
-----	-------	------------------	----------

Note 2 - Not available for repair

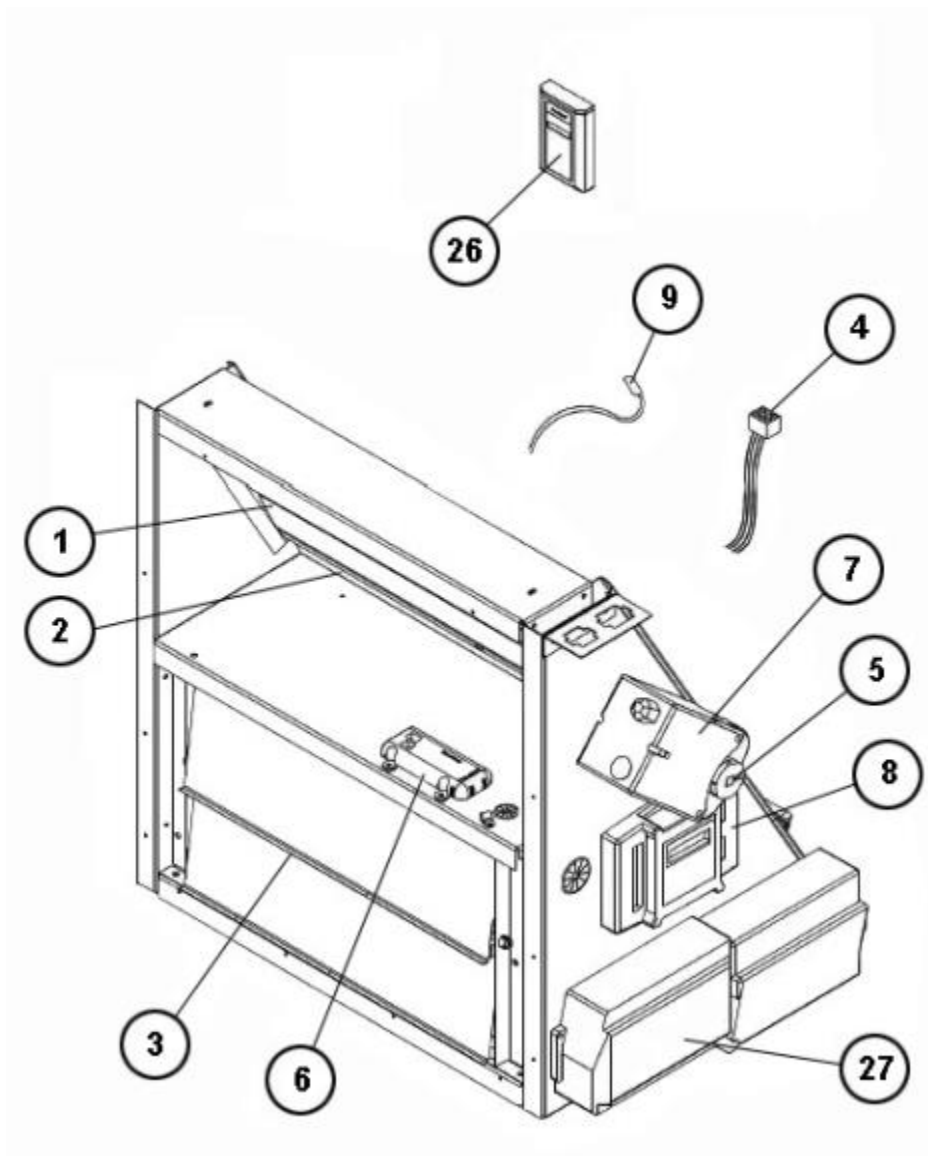

AXRD-01RECBM3 Assy

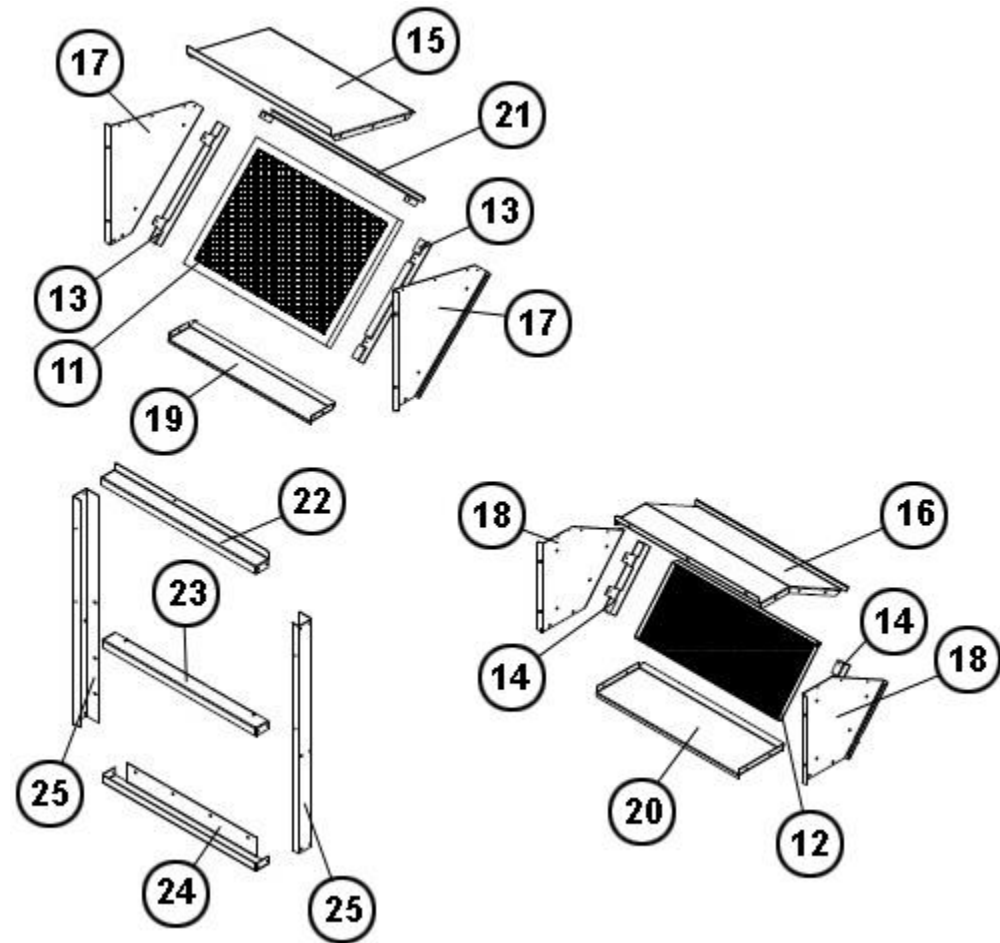

AXRD-01RECBM3 Hood