

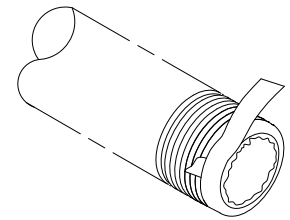

REFERENCE DRAWINGS	
HOSE BIB ASSY	9989-000-002
REPLACEMENT PARTS	9989-005-002

NOTES:

1. CONSULT LOCAL CODES FOR VACUUM BREAKER REQUIREMENTS.
2. UNIT IS NOT INTENDED FOR INSTALLATION IN AREAS THAT ARE SUBJECT TO FREEZING.
3. MAXIMUM RECOMMENDED WORKING PRESSURE IS 100 PSI; MAXIMUM TEMPERATURE IS 130° F.



START TEFLON TAPE SEALANT CORRECTLY

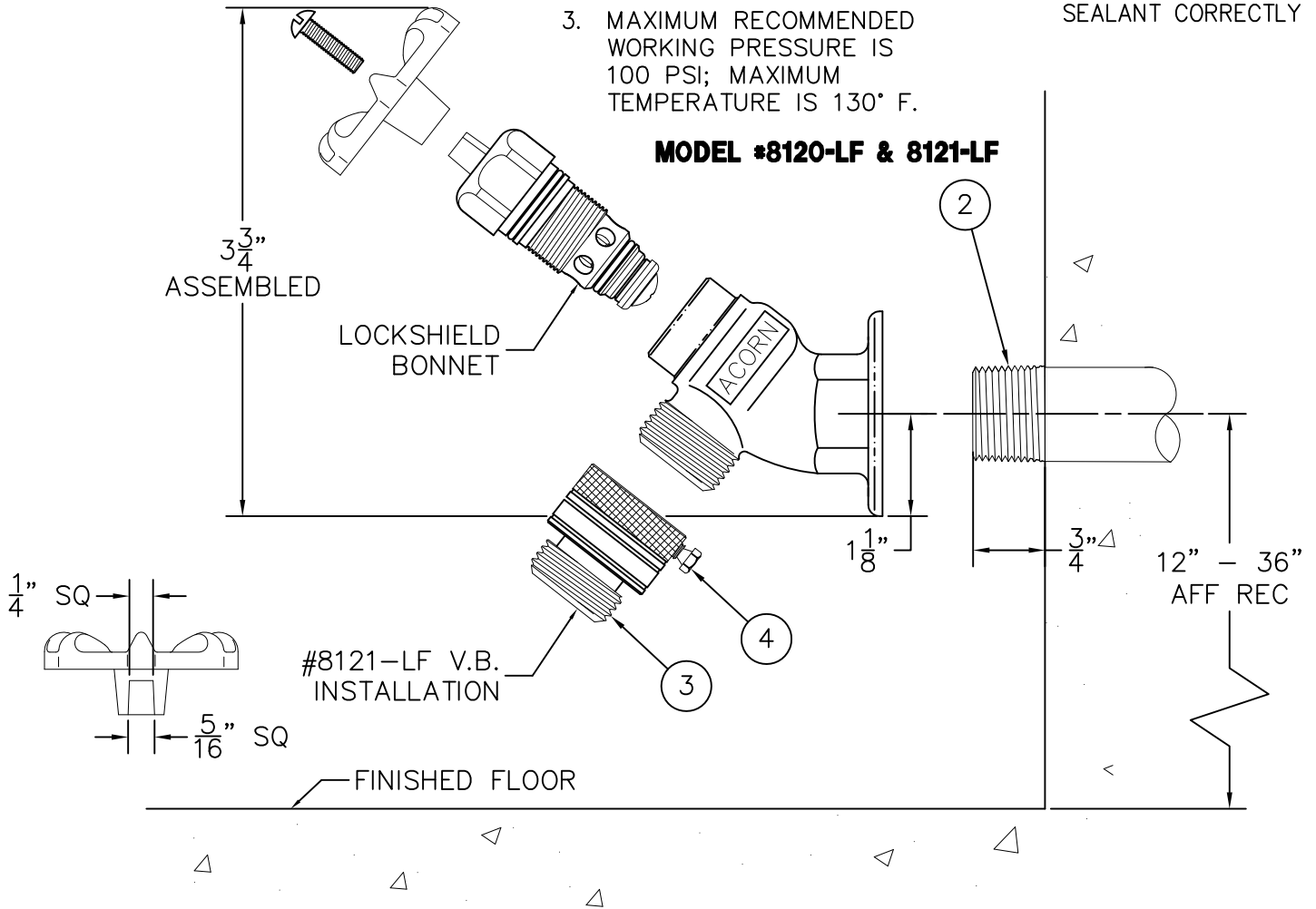

INSTALLATION INSTRUCTIONS:

- A- ROUGH-IN FOR ① 3/4" FEMALE INLET. MAINTAIN RECOMMENDED MINIMUM LENGTH ABOVE GROUND. REFER TO LOCAL CODES.
- B- THOROUGHLY FLUSH SUPPLY STUB OUT ② PRIOR TO MAKING UP CONNECTIONS. SEAL THREAD END OF STUB OUT WITH TEFLON OR OTHER SEALING COMPOUND.
- C- THREAD HOSE BIB ① TO SUPPLY STUB OUT ② UNTIL HAND TIGHT, THEN WITH AN APPROPRIATE WRENCH, TURN TO DESIRED ORIENTATION AND CHECK FOR LEAKS.
- D- FOR 8121-LF: THREAD VACUUM BREAKER ③ TO HOSE BIB. TIGHTEN SET SCREW ④ AS REQUIRED.

<p>ACORN ENGINEERING COMPANY P.O. BOX 3527 Industry, CA 91744 15125 Proctor Ave Industry, CA 91746 (626) 336-4561 FAX (626) 961-2200</p>	<p>TITLE MODEL #8120-LF & #8121-LF, 3/4" BENT NOSE, HOSE BIB FLANGED VALVE</p>		
	<p>MANUFACTURE DATE</p> <p>JANUARY 1970</p> <p>PRESENT</p>	<p>DATE ISSUED</p> <p>9/21/95</p>	<p>DRAWING NUMBER</p> <p>9901-031-001</p>
		<p>DATE REVISED</p> <p>09/15/14</p>	



Model #8125-LF & 8126-LF

REFERENCE DRAWINGS	
HOSE BIB ASSY	9989-003-002
REPLACEMENT PARTS	9989-005-002

NOTES:

1. CONSULT LOCAL CODES FOR VACUUM BREAKER REQUIREMENTS.
2. UNIT IS NOT INTENDED FOR INSTALLATION IN AREAS THAT ARE SUBJECT TO FREEZING.
3. MAXIMUM RECOMMENDED WORKING PRESSURE IS 100 PSI; MAXIMUM TEMPERATURE IS 130° F.

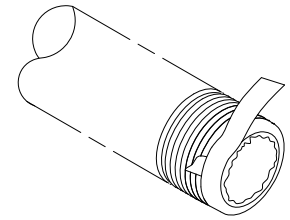

START TEFLON TAPE SEALANT CORRECTLY

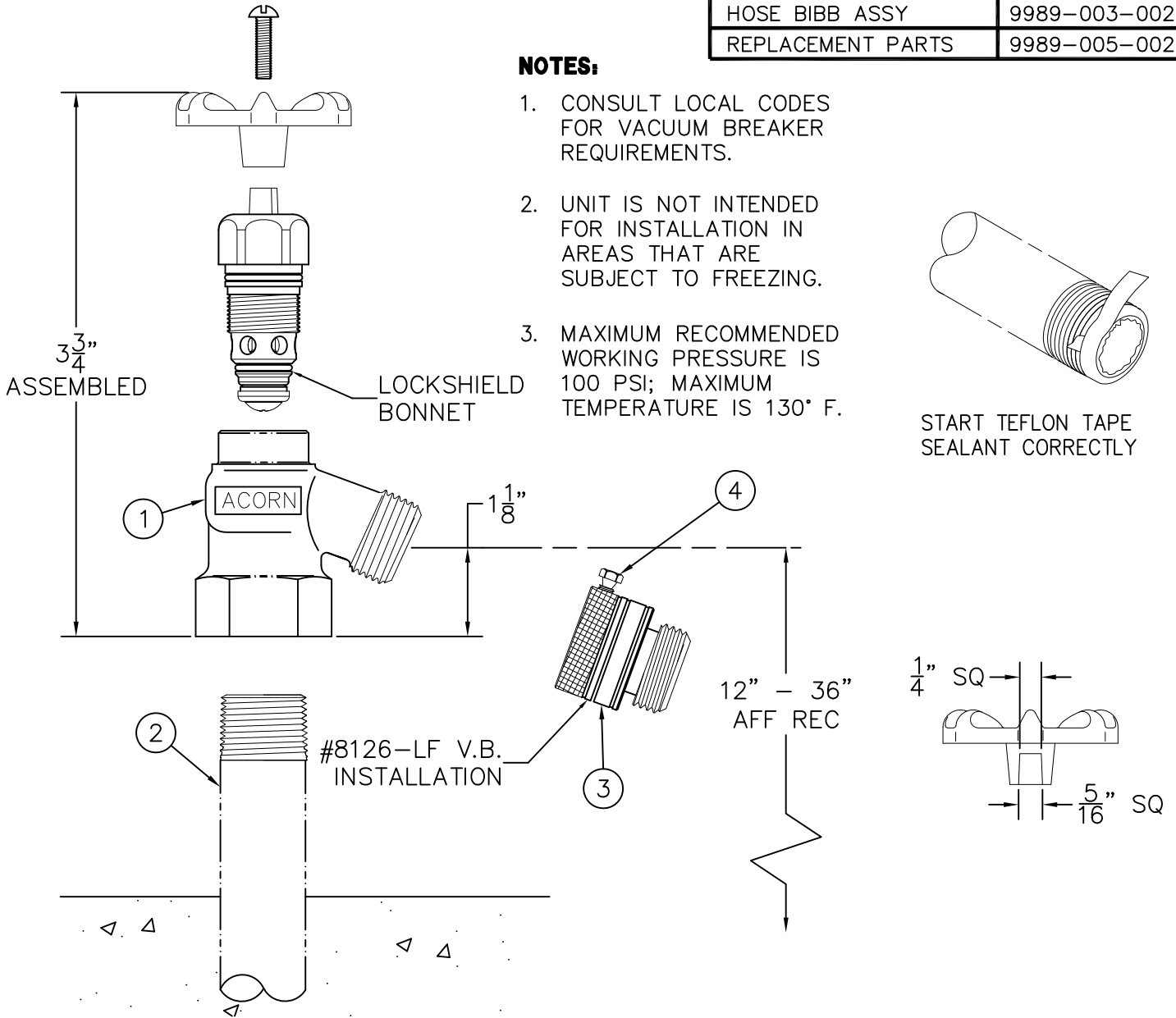

INSTALLATION INSTRUCTIONS:

- A- ROUGH-IN FOR (1) 3/4" NPTI FEMALE INLET. MAINTAIN RECOMMENDED MINIMUM LENGTH ABOVE GROUND. REFER TO LOCAL CODES.
- B- THOROUGHLY FLUSH SUPPLY STUB OUT (2) PRIOR TO MAKING UP CONNECTIONS. SEAL THREAD END STUB OUT WITH TEFLON OR OTHER SEALING COMPOUND.
- C- THREAD HOSE BIB (1) TO SUPPLY STUB OUT (2) UNTIL HAND TIGHT, THEN WITH AN APPROPRIATE WRENCH, TURN TO DESIRED ORIENTATION AND CHECK FOR LEAKS.
- D- FOR 8126-LF: THREAD VACUUM BREAKER (3) TO HOSE BIB. TIGHTEN SET SCREW (4) AS REQUIRED.

<p>ACORN ENGINEERING COMPANY P.O. BOX 3527 Industry, CA 91744 15125 Proctor Ave Industry, CA 91746 (626) 336-4561 FAX (626) 961-2200</p>	<p>TITLE MODEL #8125-LF & #8126-LF, 3/4" BENT NOSE, HOSE BIB VALVE</p>		
	<p>MANUFACTURE DATE</p> <p>JANUARY 1970</p> <p>PRESENT</p>	<p>DATE ISSUED</p> <p>6/1/97</p> <p>DATE REVISED</p> <p>09/15/14</p>	<p>DRAWING NUMBER</p> <p>9901-030-001</p>