

ElectriFLEX LD™ (Light Duty) Commercial Utility Electric Water Heater

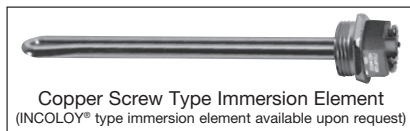

Photo is of
LE112T3-1

Bradford White ElectriFLEX LD™ Utility Electric Models Feature:

- **Fully Automatic Thermostat Controls**—Fast acting surface-mount thermostats with a maximum setpoint of 175°F and a high limit energy cut-off (manual reset) for safety.
- **Direct Heat Transfer With a Single Immersed Element**—Transfers heat directly and efficiently to the water. Screw-in style element.
- **Vitraglas® Lining with Microban®**—An exclusively engineered enamel formula that provides superior tank protection from the corrosive effects of water; and with Microban® antimicrobial product protection to help prevent the growth of bacteria, mold and mildew on the surface of the tank lining).
- **Insulation System**—1" (25mm) Non-CFC foam insulation covers the sides and top of the tank, reducing heat loss. This results in less energy consumption, improved efficiencies, and jacket rigidity.
- **Water Connections**—3/4" (19mm) NPT factory-installed true dielectric fittings extend water heater life and simplify water line connections. Located on the side for easier installation (Fittings packaged separately inside carton).
- **Protective Anode Rod**—Provides added protection against corrosion for long trouble-free service.
- **Steel Tank**—Heavy gauge steel automatically formed, rolled, and welded.
- **Voltages Available**—120V, 208V, 240V, 277V, 380V, 415V, 480V.
- **Single Phase Operation Only.**
- **Field Conversion Kits**—Change voltage, and kW in the field (see options on following page).
- **T&P Relief Valve**—Installed.

FEATURING:



3 or 5-Year Limited Tank Warranties / 1-Year Limited Warranty on Component Parts.

For more information on warranty, please visit www.bradfordwhite.com

For products installed in USA, Canada, and Puerto Rico. Some states do not allow limitations on warranties. See complete copy of the warranty included with the heater.

Microban® antimicrobial product protection helps prevent the growth of bacteria, mold and mildew that may affect the product. The built-in antimicrobial properties do not protect users or others from disease-causing organisms. Microban® is a registered trademark of Microban Products Company.



ElectriFLEX LD™ (Light Duty) Commercial Utility Electric Water Heater

ElectriFLEX LD™ Utility Electric Models

C.E.C. Listed

Model Number	Nominal Gal. Capacity		Recovery at 100°F Rise*		A Floor to Top of Heater	B Jacket Dia.	C Floor to C/L of Hot Water Conn.	D Floor to C/L of Cold Water Conn.	E Floor to T&P Conn.	F Floor to Anode Rod	Water Conn. NPT	Approx. Shipping Weight
	U.S. Gal.	Imp. Gal.	U.S. GPH	Imp. GPH	in.	in.	in.	in.	in.	in.	in.	lbs.
LE16U3-1†	6	5	6	5	16 1/2	14	10 1/8	3 1/8	10 1/8	N/A	3/4	33
LE110U3-1	10	8	6	5	17 1/2	16	15	5 11/16	14	9 11/16	3/4	48
LE112T3-1†	12	10	6	5	27 3/4	14	21 1/8	3	21 1/8	N/A	3/4	48
LE120U3-1	19	16	6	5	24 3/4	18	18 1/2	3	18 1/2	N/A	3/4	59

Model Number	Nominal Liter Capacity	Recovery 56°C Rise*		A Floor to Top of Heater	B Jacket Dia.	C Floor to C/L of Hot Water Conn.	D Floor to C/L of Cold Water	E Floor to T&P Conn.	F Floor to Anode Rod	Water Conn. NPT	Approx. Shipping Weight
		Liters/ Hour	mm.	mm.	mm.	mm.	mm.	mm.	mm.	mm.	kg.
LE16U3-1†	23	23	419	356	257	79	257	N/A	19	15	
LE110U3-1	38	23	445	406	381	144	355	246	19	22	
LE112T3-1†	45	23	705	356	537	76	537	N/A	19	22	
LE120U3-1	72	23	629	457	470	76	470	N/A	19	27	

Specify wattage and voltage when ordering. Use chart below for maximum wattages at certain voltages.

† Maximum wattage at any voltage is 3000W. For 5 year models, change suffix "3" to "5".

Single element only. *Based on 1500W operation. NSF Kits available when ordering.

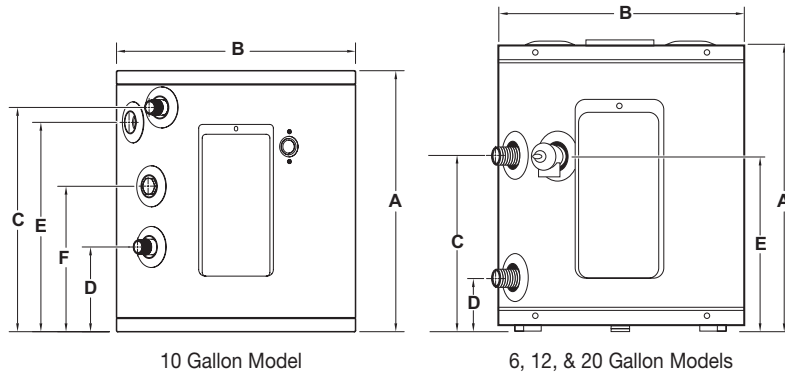

Wattage	Recovery S GPH Temperature Rise °F					Wattage	Recovery S LPH Temperature Rise °C				
	60	80	90	100	120		34	45	50	56	67
1500W	10	8	7	6	5	1500W	38	30	26	23	19
2000W	14	10	9	8	7	2000W	53	38	34	30	26
2500W	17	13	11	10	9	2500W	64	49	42	38	34
3000W	21	15	14	12	10	3000W	79	57	53	45	38
3500W	24	18	16	14	12	3500W	91	68	61	53	45
4000W	28	21	18	16	14	4000W	106	79	68	61	53
4500W	31	23	21	19	15	4500W	117	87	79	72	57
5000W	34	26	23	21	17	5000W	129	98	87	79	64
5500W	38	29	25	23	19	5500W	144	110	95	87	72
6000W	41	31	28	25	21	6000W	155	117	106	95	79

Voltage and Wattage Conversion Kits

Single Element Wattage	Voltage						
	120V	208V	240V	277V	380V	415V	480V
1500W	415-46409-01	415-46409-05	415-46409-13	415-46409-16	415-46409-24	415-46409-41	415-46409-32
2000W	415-46409-02*	415-46409-06	415-46409-05	415-46409-17	415-46409-43	415-46409-24	415-46409-33
2500W	415-46409-03*	415-46409-07	415-46409-06	415-46409-18	415-46409-25	415-46409-43	415-46409-34
3000W	415-46409-04*	415-46409-08	415-46409-14	415-46409-19	415-46409-26	415-46409-25	415-46409-35
3500W	N/A	415-46409-09	415-46409-07	N/A	415-46409-54	415-46409-26	N/A
4000W	N/A	415-46409-49	415-46409-08	415-46409-20	415-46409-56	415-46409-54	415-46409-36
4500W	N/A	415-46409-11	415-46409-09	415-46409-51	415-46409-57	415-46409-55	415-46409-59
5000W	N/A	415-46409-50	415-46409-15	415-46409-52	415-46409-58	415-46409-56	415-46409-38
5500W	N/A	415-46409-65*	415-46409-49	415-46409-61**	415-46409-63	415-46409-57	415-46409-62**
6000W	N/A	415-46409-66*	415-46409-48*	415-46409-53	415-46409-64	415-46409-58	415-46409-60

Wattage Limitations	Voltage						
	120V	208V	240V	277V	380V	415V	480V
1500W	yes	yes	yes	yes	yes	yes	yes
2000W	yes	yes	yes	yes	yes	yes	yes
2500W	yes	yes	yes	yes	yes	yes	yes
3000W	yes	yes	yes	yes	yes	yes	yes
3500W	no	yes	yes	no	yes	yes	no
4000W	no	yes	yes	yes	yes	yes	yes
4500W	no	yes	yes	yes	yes	yes	yes
5000W	no	yes	yes	yes	yes	yes	yes
5500W	no	yes	yes	no	yes	yes	yes
6000W	no	yes	yes	yes	yes	yes	yes

Note: Above chart can be used to determine maximum wattage at certain voltages. **INCOLOY® element only. * 415-46409-02, -03, -04, -48, -65, & -66 contain only one element. These kits cannot be wired as simultaneous. These are non-simultaneous kits only. Except where noted above, each kit will include two replacement elements, two gaskets, a rating plate overlay and one set of instructions. For water heaters with only one element, please retain the extra element and gasket as a service part.

General:

All models are exempt from NAECA requirements and ASHRAE Standard 90.1b. All models UL® listed. These heaters are wired Single Phase, 120V with one 1500W element, unless otherwise specified. All water and electrical connections are 3/4" (19mm) NPT. All models certified at 300 PSI test pressure (2068 kPa) and 150 PSI working pressure (1034 kPa). Applicable models CSA verified for energy performance in accordance with C191.1-M90.

Dimensions and specifications subject to change without notice in accordance with our policy of continuous product improvement.

— BRADFORD WHITE IS —



Sales: 800-523-2931 ■ Fax 215-641-1612

24/7 Technical Support: 800-334-3393 ■ Email techserv@bradfordwhite.com

Products made by Bradford White are manufactured in the United States using the finest raw materials and components from around the world.

Built to be the Best®