



# Installation Manual



Aquastat wells provided for monitoring and controlling tank temperature



Closed-cell foam insulation provides low standby loss



Large tank connections accommodate flow rates required by low mass equipment

## Boiler Buddy® Installation Manual

Technical information contained in this publication is for reference purposes only and is subject to change without notice. Every effort has been made to supply complete and accurate information; however, Hot Water Products assumes no responsibility and will not be liable for any errors, omissions, damage, or loss that might result from any use of this manual or the information contained therein.

Reference to System Configurations and Specifications supercede all previous information and are subject to change without notice.

Boiler Buddy® is a registered trademark of Hot Water Products, Inc.

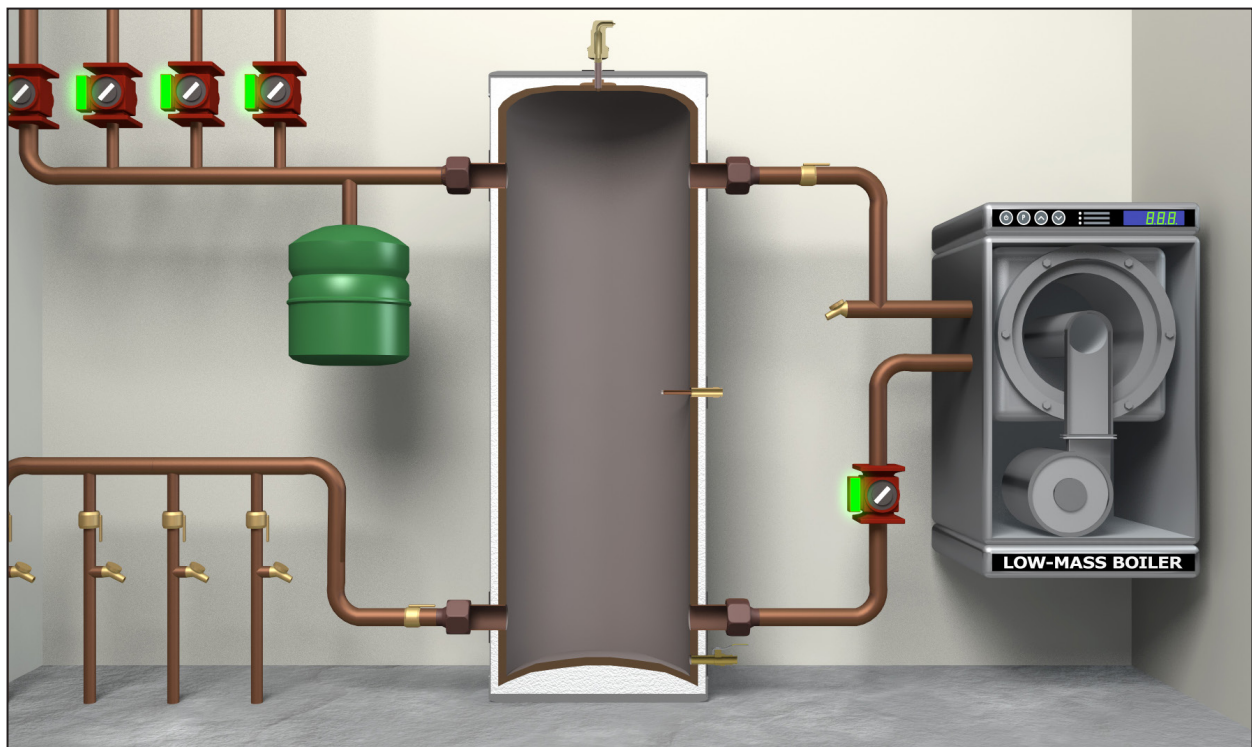

# Table of Contents

Overview . . . . . 1  
 Specifications . . . . . 2  
 BB-80-C Specifications Page . . . . . 3

<p>Concept Drawings / Schematics</p>
--------------------------------------

BB-18 | BB-30 with Boiler . . . . . 4  
 BB-30 with Boiler & Indirect Water Heater . . . . . 5  
 BB-30 with Boiler & Indirect Multi-Temp . . . . . 6  
 BB-50-G with Geo-Thermal . . . . . 7  
 BB-80-3W with Two Boilers & Indirect . . . . . 8  
 BB-80-C with Boiler & Wood Boiler . . . . . 9  
 BB-80-C with Geo-Thermal & Boiler Back-Up . . . . . 10  
 BB-80-C with Boiler & Solar . . . . . 11  
 BB-119-3W with Geo-Thermal . . . . . 12



# Boiler Buddy® Buffer Tank

## Models: BB-18, BB-30, BB-50-G, BB-80-3W, BB-80-C & BB-119-3W

- The BB-18 and BB-30 come with 1 aquastat well.
- The BB-50-G, BB-80-3W, and BB-119-3W come with 3 aquastat wells.
- The BB-80-C comes with an internal heat exchanger coil and 1 aquastat well.

The Boiler Buddy is available in 18, 30, 80, 50 and 119 gallon capacities. It is designed to be used in heating systems with low-mass boilers, geothermal, chilled water applications, or low-mass radiation. Boilers operating at low loads may short cycle which can lead to sooting, premature component failure (nuisance lockouts) and inefficiency.

The Boiler Buddy tank is a factory insulated (polyurethane foam) and jacketed storage tank, adding mass to the system and providing the necessary buffer

to prevent short cycling. If the boiler firing cycle is extended for a minimum of several minutes, the full efficiency of the boiler can be achieved and nuisance problems can be avoided.

The Boiler Buddy also creates a low velocity state within the system, providing air elimination, assisting in the removal of sediment and debris, and acting as a hydraulic separator between required flows from the boiler(s) and the multiple flow rates needed for the secondary zones. The ball drain for sediment removal also

acts as an excellent way to fast fill the system.

Excessive draining from the Boiler Buddy is not recommended, as it introduces more contaminants into the system. Routine maintenance of the closed-loop system should be performed once per year, or sooner as per boiler manufacturer recommendations.

**Note: Boiler Buddy buffer tanks are not for use with potable water!**

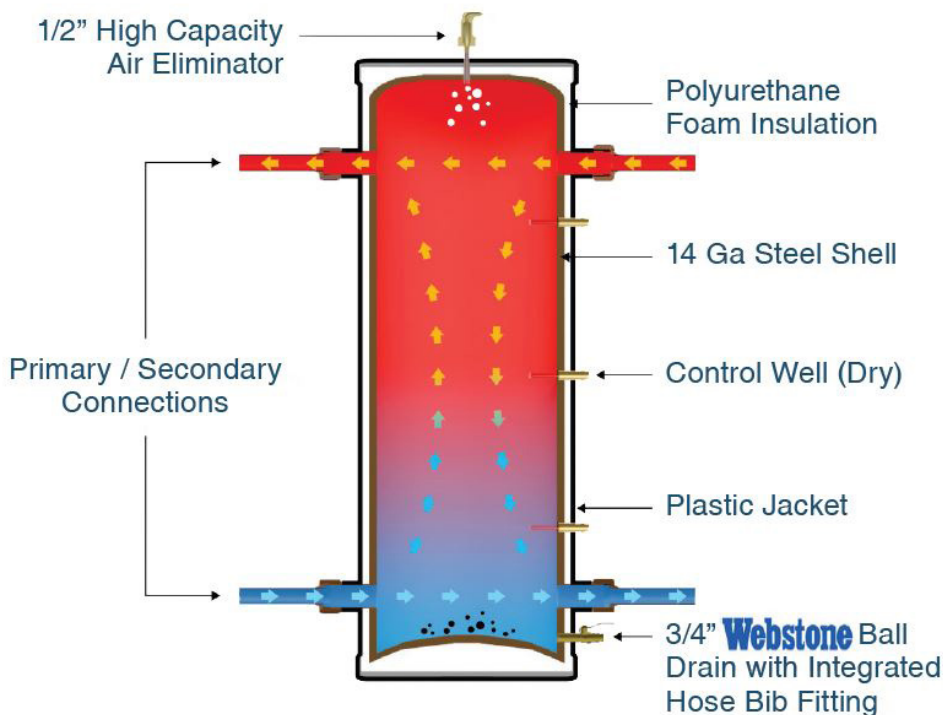

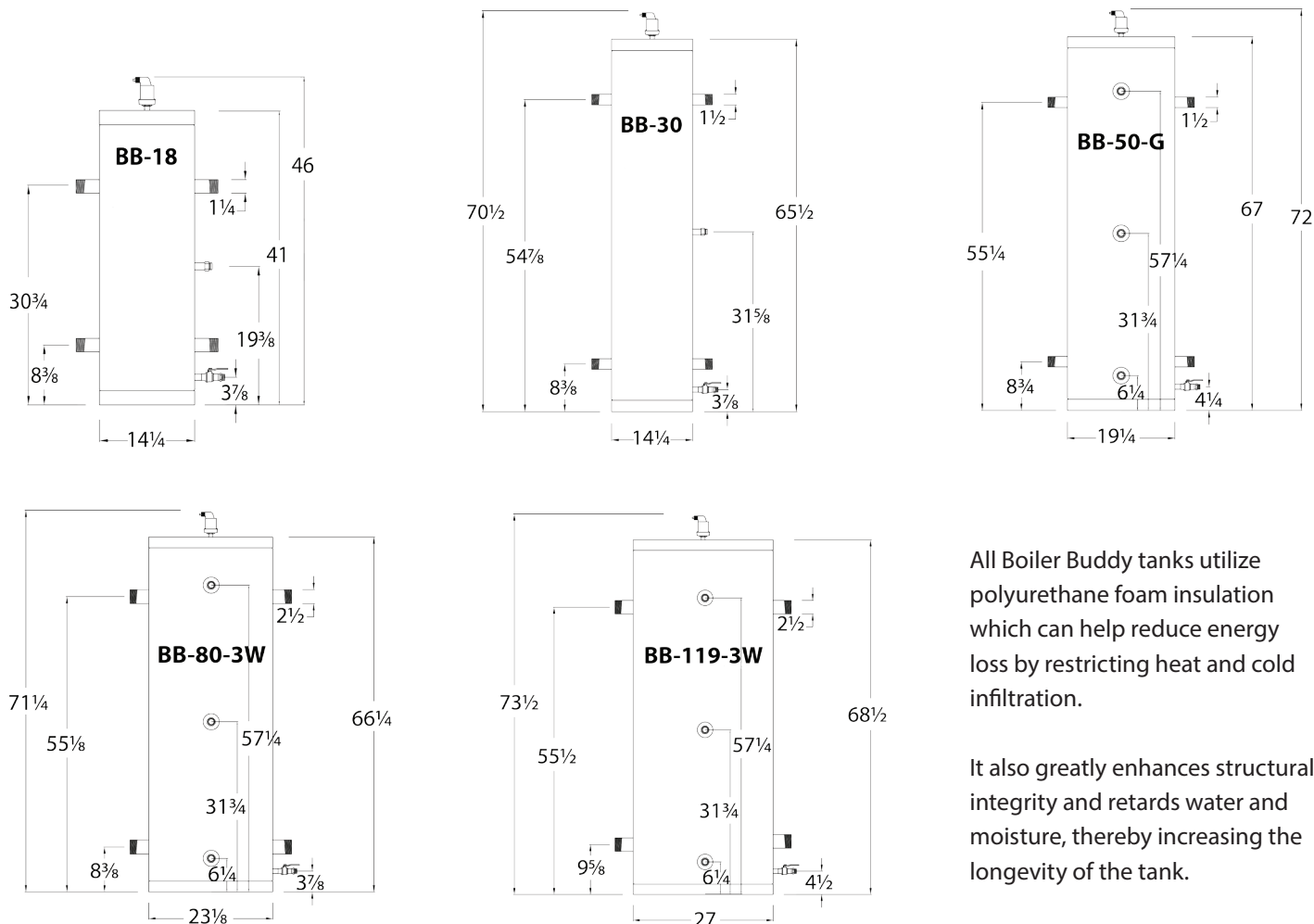

All Boiler Buddy tanks utilize polyurethane foam insulation which can help reduce energy loss by restricting heat and cold infiltration.

It also greatly enhances structural integrity and retards water and moisture, thereby increasing the longevity of the tank.

Model	Height	Diameter	Capacity Gallons	Max Pressure PSI	Number of Sensor Wells
BB-18	46"	14-1/4"	18	75	1
BB-30	70-1/2"	14-1/4"	30	75	1
BB-50-G	72"	19-1/4"	50	75	3
BB-80-3W	71-1/4"	23-1/8"	80	75	3
BB-80-C (includes coil)	69"	24"	80	75	1
BB-119-3W	73-1/2"	27"	119	75	3

Model	Primary/Secondary Connections NPT Male	Drain Connections NH(M)	Air Vent	Shipping Weight
BB-18	1-1/4"	3/4"	1/2"	55
BB-30	1-1/2"	3/4"	1/2"	83
BB-50-G	1-1/2"	3/4"	1/2"	115
BB-80-3W	2-1/2"	3/4"	1/2"	128
BB-80-C (includes coil)	2-1/2"	3/4"	1/2"	300
BB-119-3W	2-1/2"	3/4"	1/2"	217

**Boiler Buddy Tanks include the following:**

- Premium high capacity air eliminator
- Brass hose bushing
- Brass aquastat well(s) (dry)
- All necessary nipples
- Premium Webstone ball drain with cap

**! WARNING !**  
**Boiler Buddy buffer tanks are NOT suitable for non-oxygen barrier tubing.**

**NOT suitable for potable water.**

## Model: BB-80-C

The BB-80-C is the only Boiler Buddy model that comes with an internal carbon steel heat exchange coil. This feature allows for flexibility in system design. Design applications include; hydronic buffer tank/heat supplemented by solar, geothermal, wood boiler, pellet stove, waste oil burner, etc.

Carbon steel coil is 36' long, 14.4 ft<sup>2</sup> and furnished with 1" NPT connections.

**! WARNING !**  
 The internal coil in the BB-C tank is made of carbon steel. This must only be connected to closed-loop pressurized systems with air elimination!

**NOT** suitable for potable water!

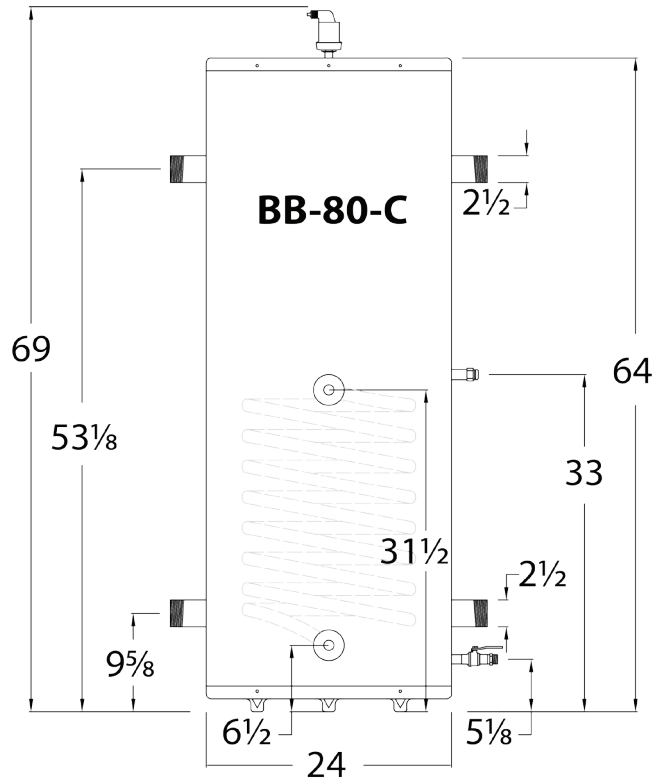

**BB-80-C Friction Loss Curve**

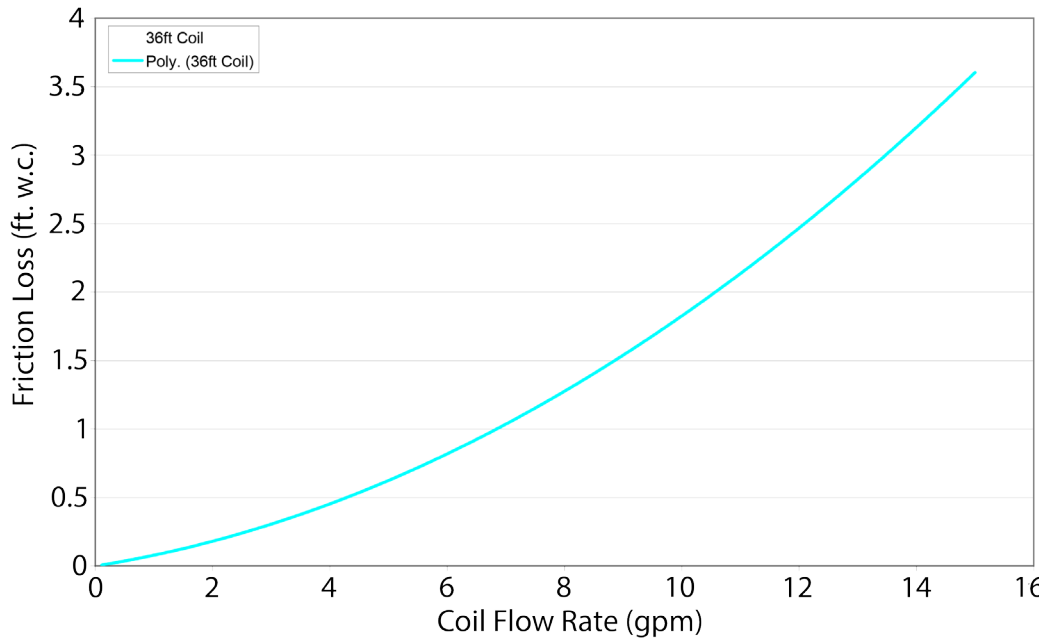

Boiler connections to the Boiler Buddy should be made as illustrated in the following piping diagrams. If the boiler connections are reversed, the system supply temperature could be tempered within the tank. To achieve maximum set point, feed the boiler supply into the top tapping.

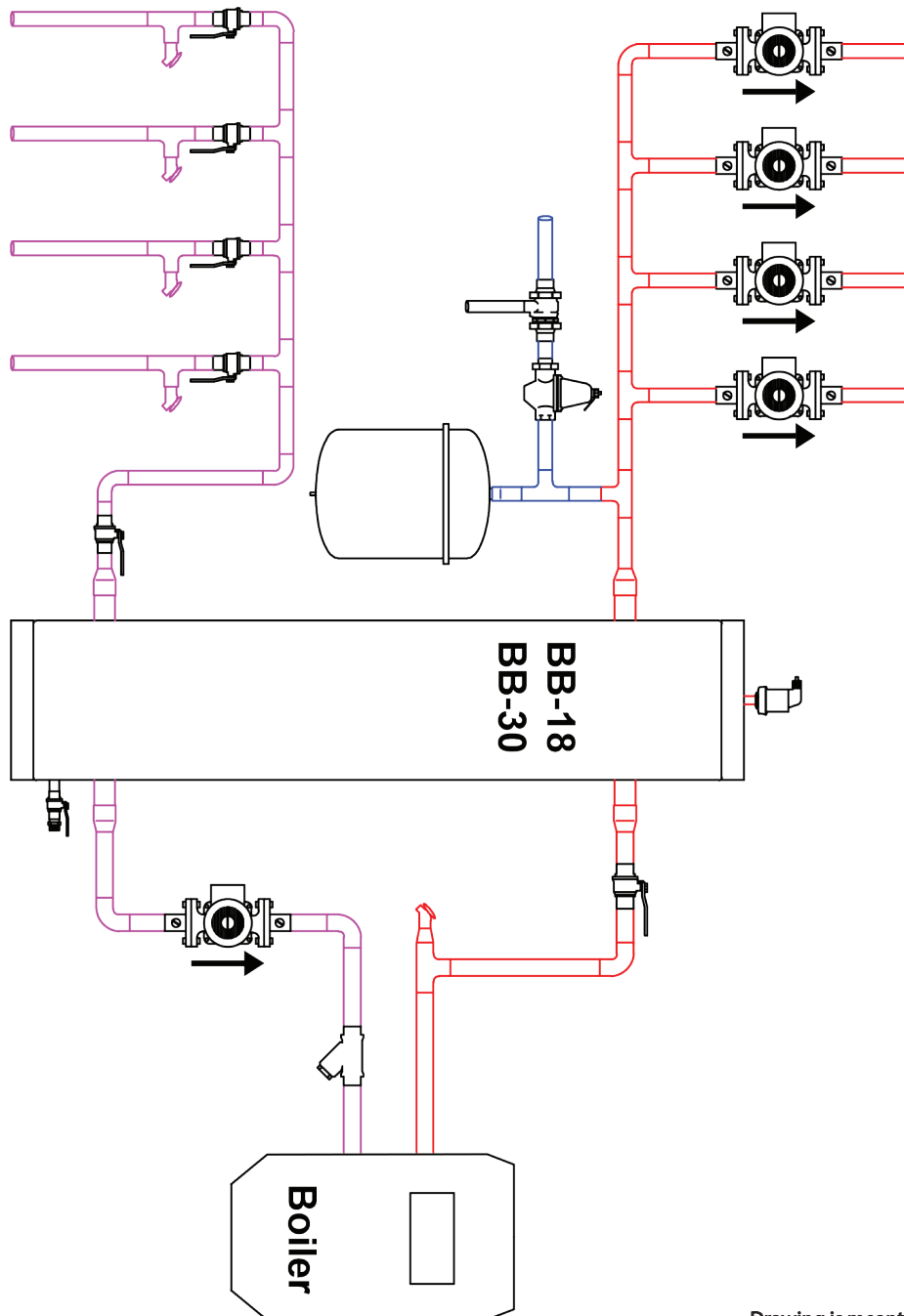

Drawing is meant to show system piping concepts only. Installing contractor is responsible for all equipment and detailing required by local codes.



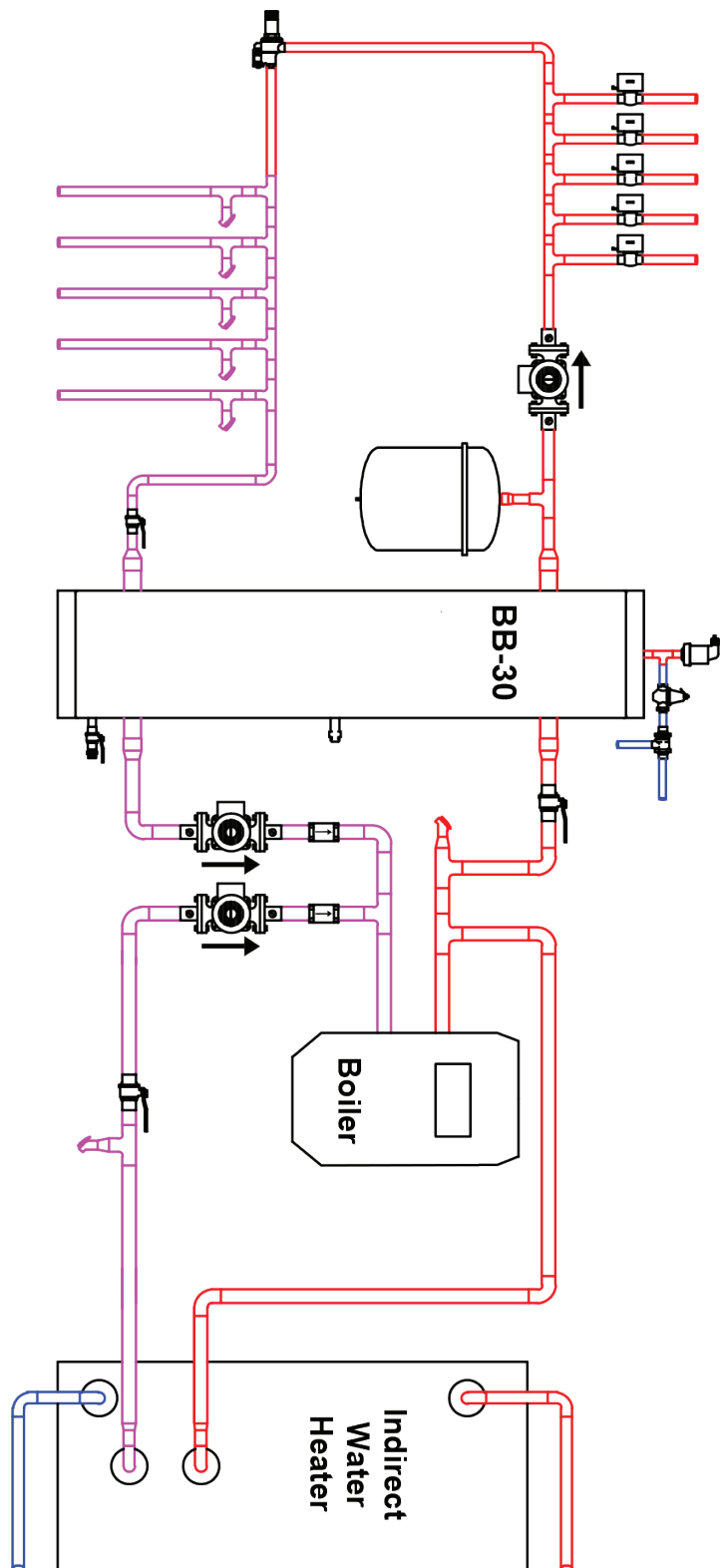

Drawing is meant to show system piping concepts only. Installing contractor is responsible for all equipment and detailing required by local codes.



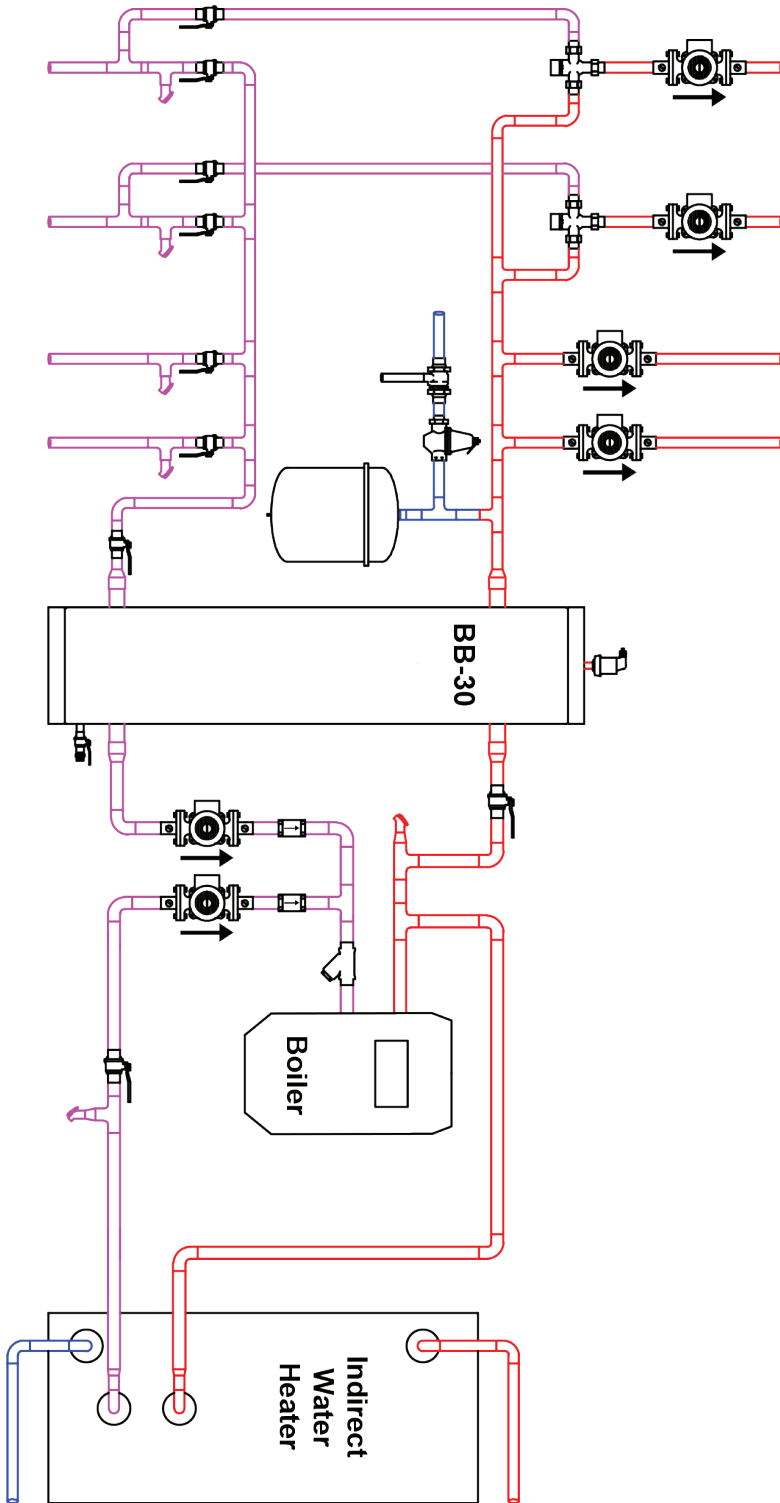

Drawing is meant to show system piping concepts only. Installing contractor is responsible for all equipment and detailing required by local codes.

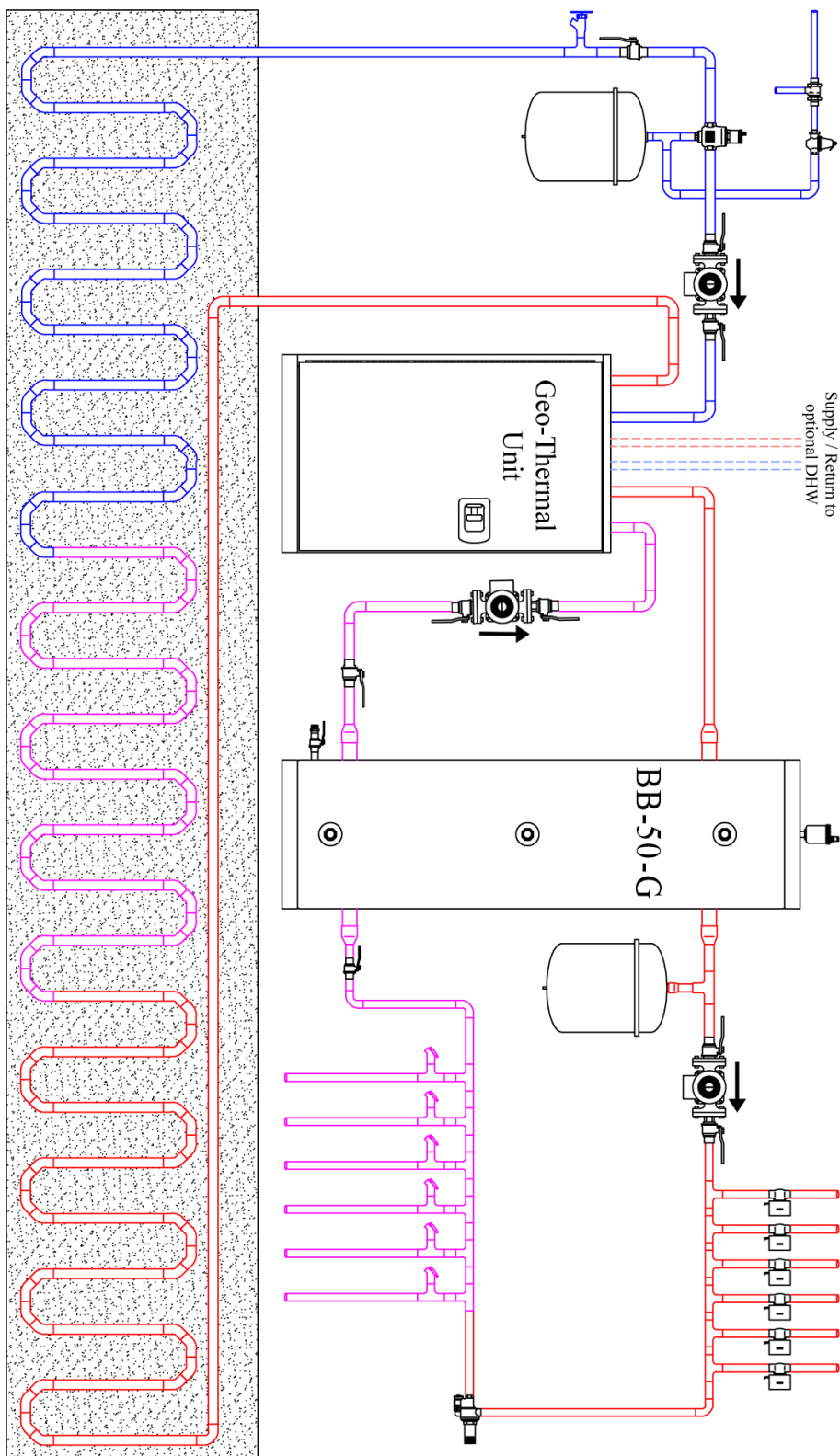

Drawing is meant to show system piping concepts only. Installing contractor is responsible for all equipment and detailing required by local codes.

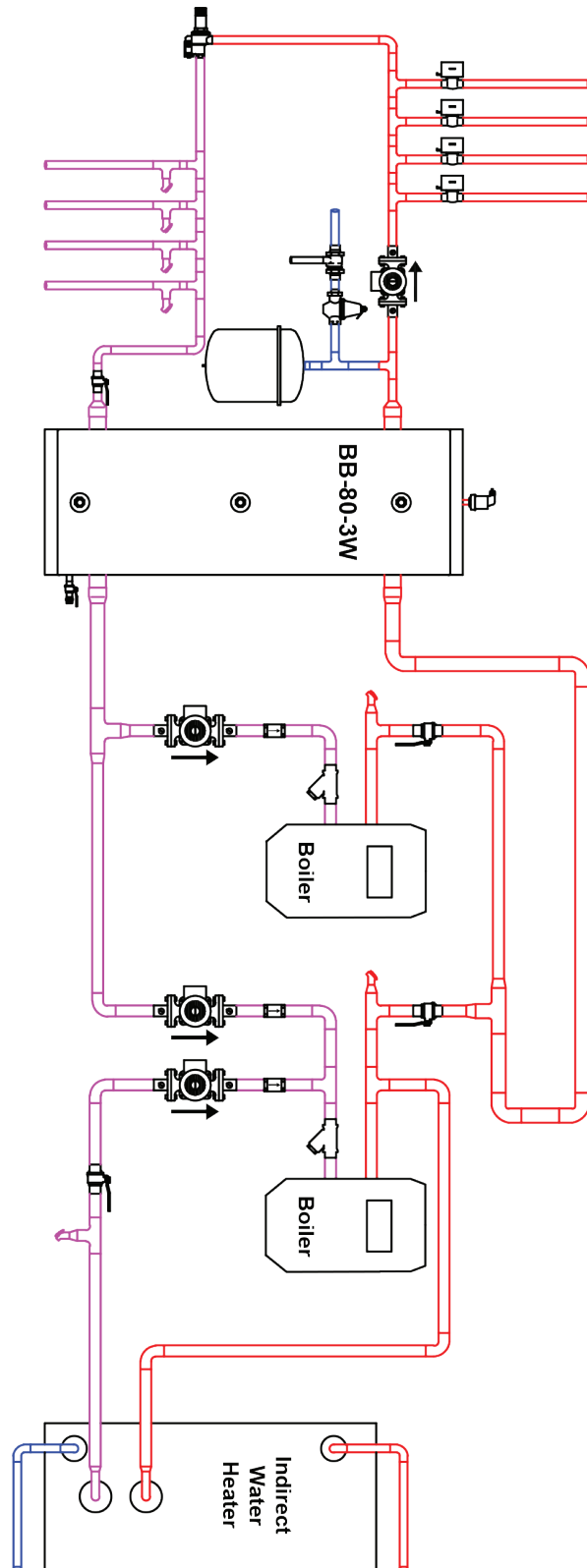

Drawing is meant to show system piping concepts only. Installing contractor is responsible for all equipment and detailing required by local codes.

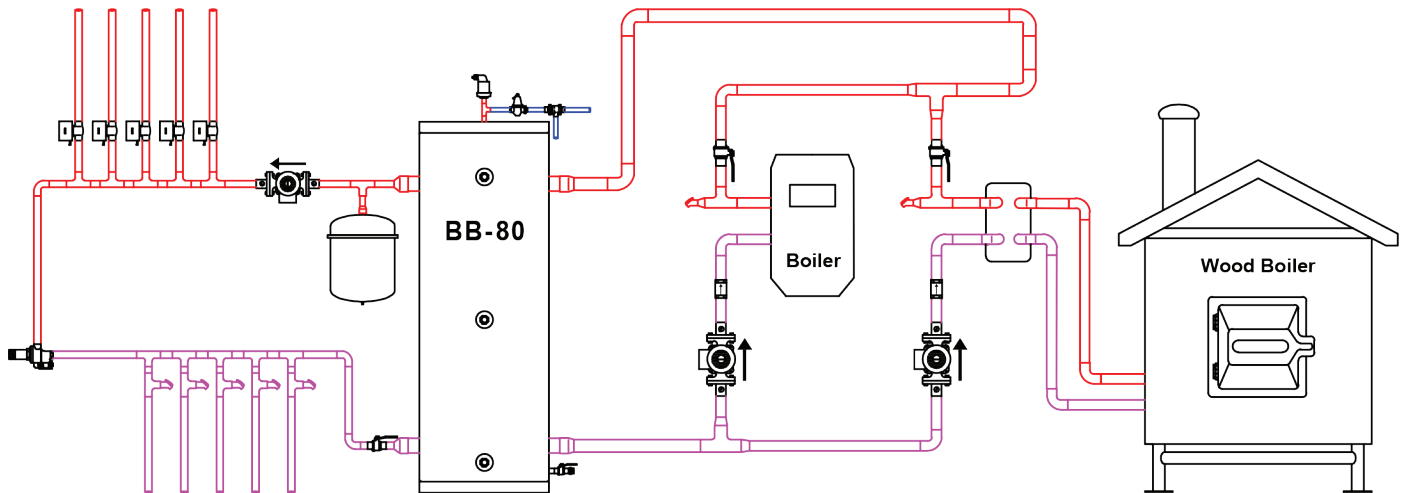
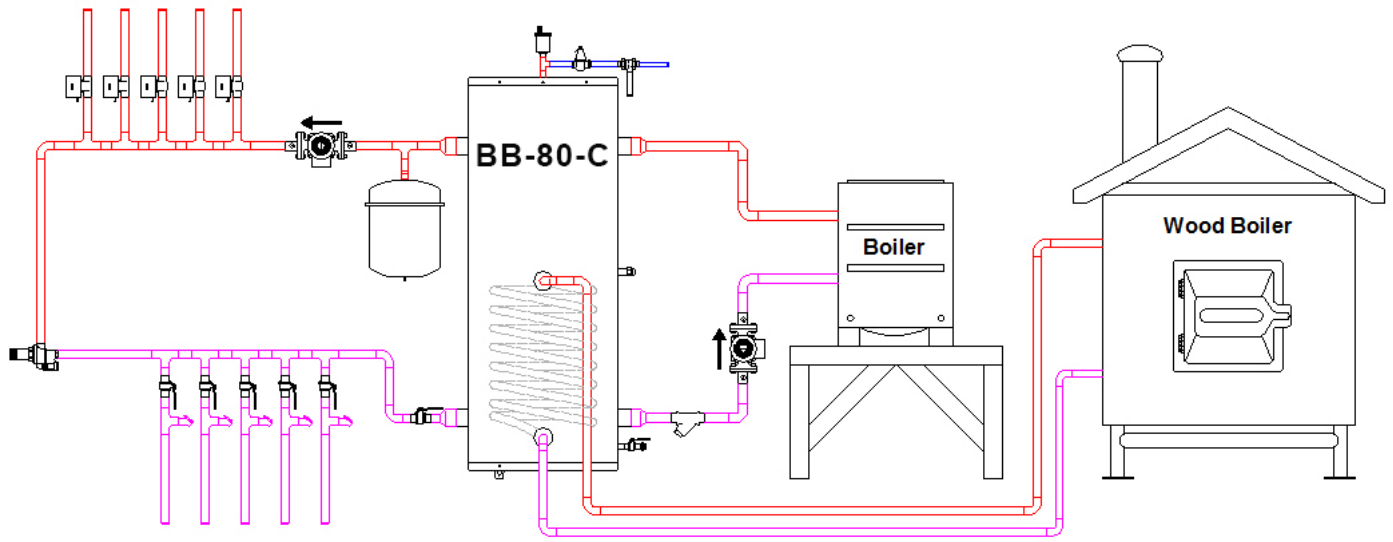

**! WARNING !**

The internal coil in the BB-80-C tank is made of carbon steel. This must only be connected to closed-loop, pressurized systems with air elimination!

Boiler Buddy Tank **NOT** suitable for potable water!

Drawing is meant to show system piping concepts only. Installing contractor is responsible for all equipment and detailing required by local codes.

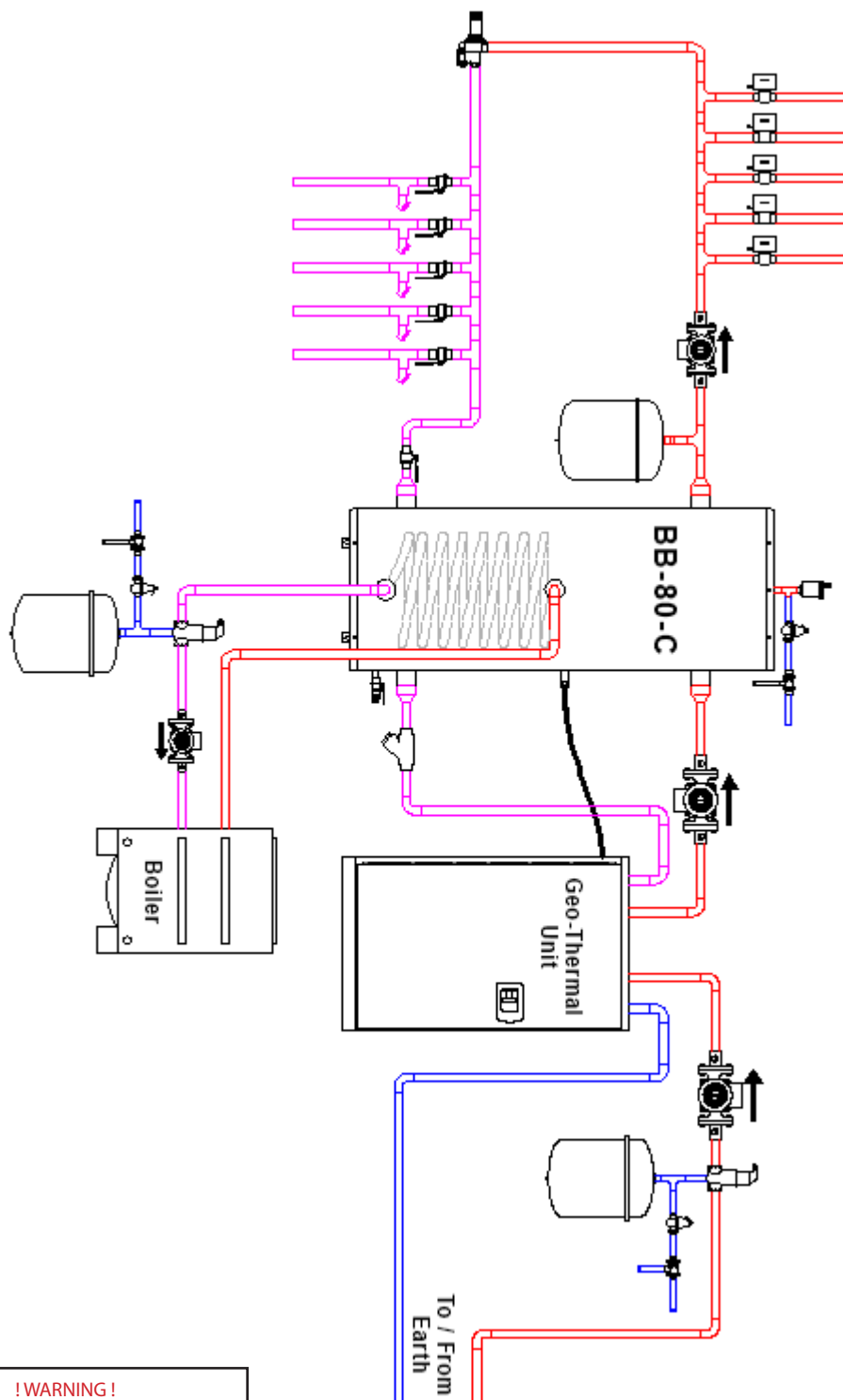

**! WARNING !**

The internal coil in the BB<sup>80</sup>C tank is made of carbon steel. This must only be connected to closed-loop pressurized systems with air elimination!

Boiler Buddy Tank **NOT** suitable for potable water!

Drawing is meant to show system piping concepts only. Installing contractor is responsible for all equipment and detailing required by local codes.

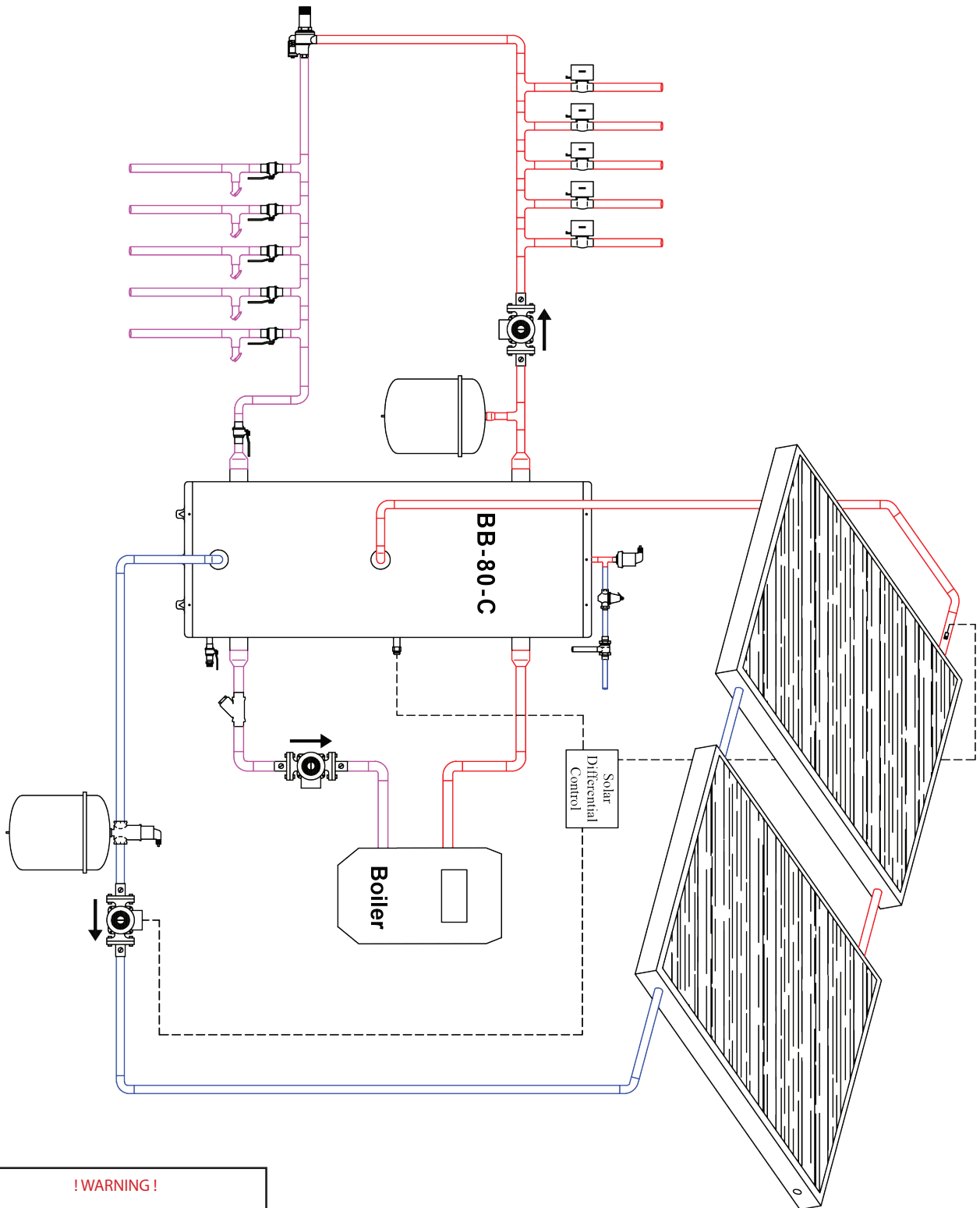

**! WARNING !**

The internal coil in the BB-80-C tank is made of carbon steel! This must only be connected to closed loop pressurized systems with air elimination!

Boiler Buddy Tank **NOT** suitable for potable water!

Drawing is meant to show system piping concepts only. Installing contractor is responsible for all equipment and detailing required by local codes.

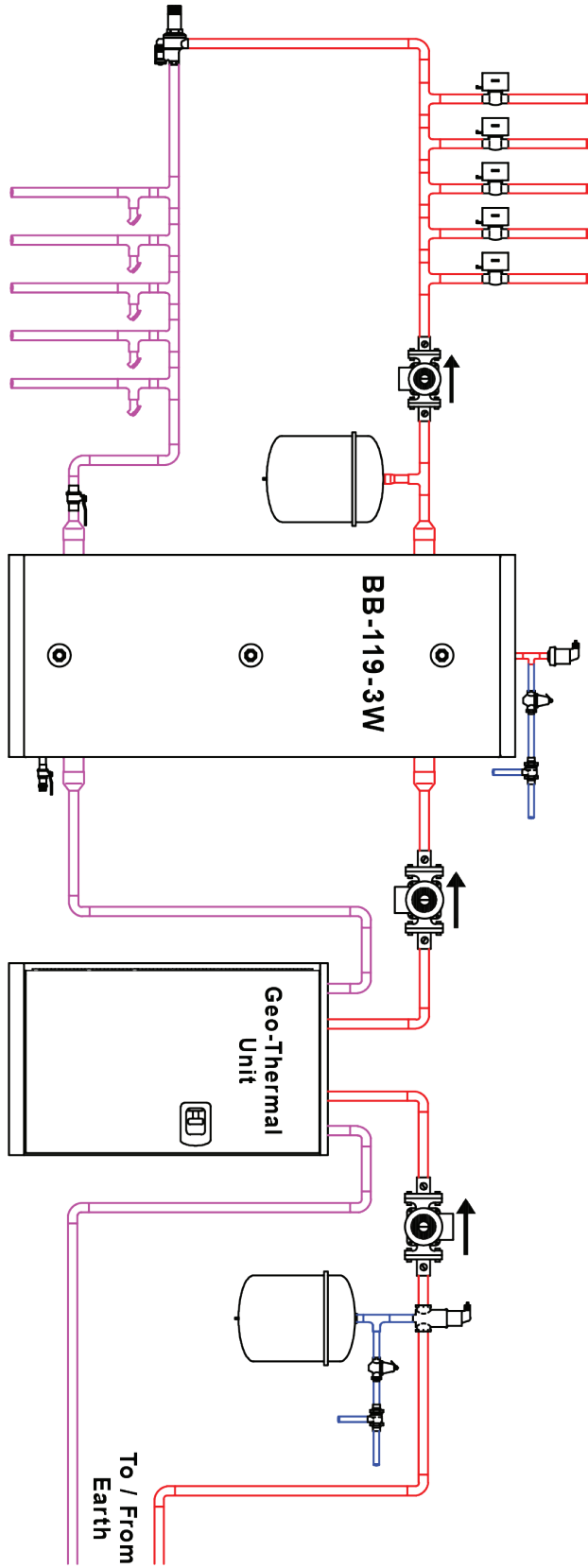

Drawing is meant to show system piping concepts only. Installing contractor is responsible for all equipment and detailing required by local codes.



---

Hot Water Products, Inc. • 7500 N. 81st Street, Milwaukee, WI 53223 • Toll-free: 877 377-0011 • Fax: 877 280-0022 • [www.BoilerBuddy.com](http://www.BoilerBuddy.com)

