

ENGINEERED TO FIT 2½" THROUGH 4" BACKFLOW PREVENTION DEVICE INSTALLATIONS

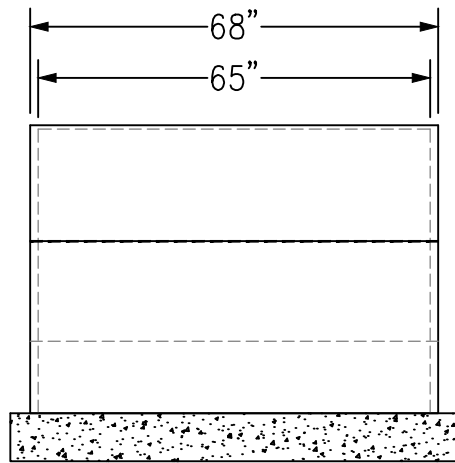

BACK VIEW  
NOT TO SCALE

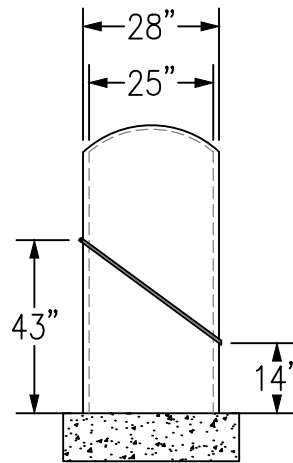

SIDE VIEW  
NOT TO SCALE

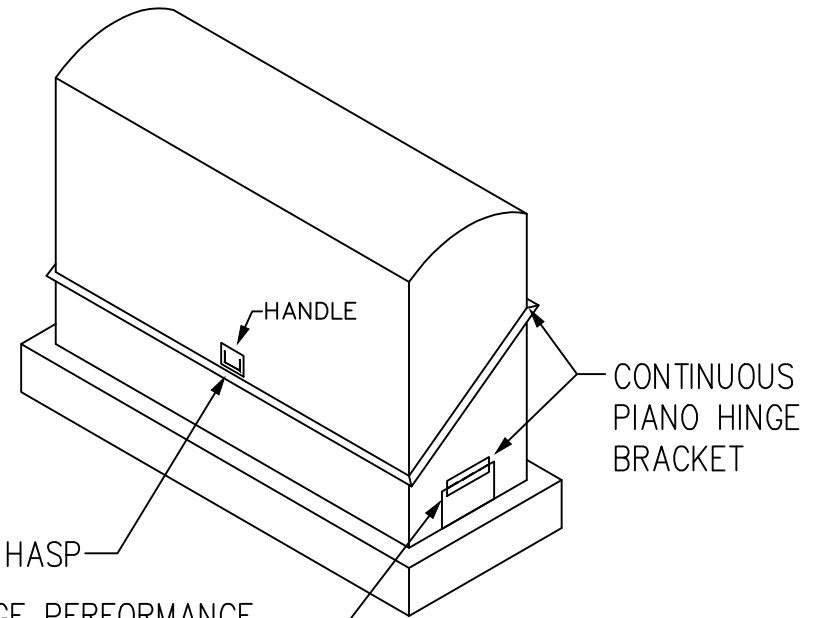

LOCKING HASP  
DISCHARGE PERFORMANCE  
FLOW RATE (GPM): 720

ISOMETRIC VIEW  
NOT TO SCALE

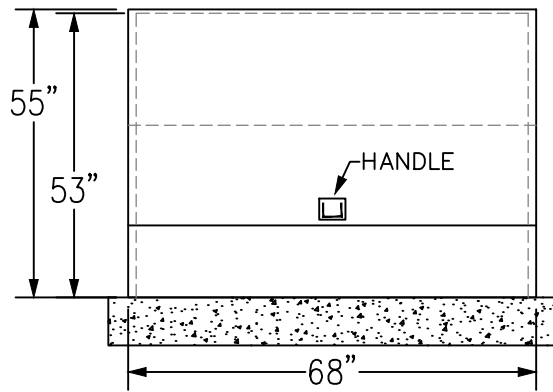

FRONT VIEW  
NOT TO SCALE

SLAB OR FOOTER  
RECOMMENDED PAD/FOOTER SIZE:  
LENGTH: 76" x 36"

**SPECIFICATION:**  
BFProducts Inc. enclosures are manufactured to ASSE-1060 standards and designed to be used to help protect Backflow Prevention Devices from freezing conditions and vandalism. Factory assembled construction will include a gelcoat shell backed with chop-strand polyresin bonded fiberglass, internally insulated using polyurethane spray-foam.  
WEIGHT: 160 LBS

Options:  
 HU-SS HEATER – Internal Heat Source, Damp Location Listed, 120v, 500w or 1000w, Thermostatically Controlled.

ASSE-1060

**BFPRODUCTS**  
CORPORATE OFFICE  
P.O. BOX 242771  
CHARLOTTE, NC 28224

PHONE: (704) 599-9407  
FAX: (704) 599-0595  
EMAIL: [bfproducts@qmarketing.biz](mailto:bfproducts@qmarketing.biz)  
WEBSITE: [WWW.BFPRODUCTS.BIZ](http://WWW.BFPRODUCTS.BIZ)

**BFProducts, Inc**  
Backflow Prevention Device Enclosures  
"We've Got You Covered"

FIBERGLASS ENCLOSURE  
MODEL # 65-APD  
Submittal Sheet

SHEET NO.  
08/01/14  
65-APD