

3. Technical Specifications

3.1 Specifications Chart

Specifications	Models		
	iQ751, Gen II	iQ1001, Gen II	iQ1501, Gen II
Type	Indoor/Outdoor, Floor Mounted		
Fuel	Preset for Natural Gas. Convertible to propane without additional parts.		
Minimum Input (Btu/h)	30,000		
Maximum Input (Btu/h)	751,000	1,001,000	1,501,000
Maximum Output (Btu/h)	705,940	940,940	1,440,960
Thermal Efficiency	94%	94%	96%
Turn Down Ratio (TDR)	25:1	33:1	50:1
Water Inlet / Outlet Connections	2" Headers with 6" OD Flange		
Gas Inlet Connection	1-1/4" Gas Inlet with 4-5/8" OD Flange		
Condensate Drain Connection	3/4" PVC		
Maximum Condensate Flow Rate (GPH)	5.4	7.2	10.8
Unit dimensions HxWxD (inches)	67.7 X 30 X 44.3 (48 cu. ft)		67.7 X 30 X 60.4 (66 cu.Ft)
Service Clearances (inches)	24" recommended on all sides		
Unit weight (lbs.)	730	800	1025
Shipping Crate Dimensions HxWxD (inches) / Weight (lbs)	87x47x67 / 972	87x47x67 / 1059	81x47x83 / 1567
Venting Type	Direct Vent (2 pipe - intake & exhaust), Power vent (1 pipe - exhaust only)		
Venting Materials (USA)	Sch. 40 PVC, Sch. 80 CPVC, Polypropylene, Stainless Steel		
Venting Materials (Canada)	Type BH Gas Vent Classes: II A (PVC), II B (CPVC), II C (Polypropylene), I (AL294C SS)		
Vent Size (Diameter)	6" Ø		
Max 6" Vent Length - Single Pipe / Power Vent	220 ft.*	130 ft.*	65 ft.*
Max 6" Vent Length - Two pipe / Direct Vent	110 ft.*	65 ft.*	35 ft.*
* Venting Note: From the maximum lengths above, deduct 5 ft. per 90° elbow and 2 ft. per 45° elbow			
Ignition	Electronic Spark Ignition		
Temperature Range	100°F – 190°F		
Temperature Stability	+/- 4°F		
Installation Location Ambient Temperature	40°F – 130°F		
Safety	Flame Rod, Thermal Fuse, Overheat Prevention Device, Fan Speed Monitor, Flue Temperature Monitor, Blocked Vent Detector, Dual Flame Sensing		
Water Pressure Min / Max (PSIG)	30 / 160		
NG/LP- Min. Static Gas Pressure (Full Fire)	NG = 2.5" WC; LP= 8" WC (set Gas regulator to 8" WC for NG 11" WC for LP)		
NG/LP - Maximum Static Gas Pressure	14" WC (set Gas regulator to 8" WC for NG 11" WC for LP)		
Gas Regulator Pressure set to	8" WC for Natural Gas, 11" WC for Propane		
Electrical	120V AC, 60 Hz		
Power Consumption	Max 16 Amps, 24W (Standby)	Max 20 Amps, 32W (Standby)	Max 29 Amps, 48W (Standby)
Internal Water Volume (gallons)	3	4	6
Note: Due to Intellihot's policy of continuous product improvements the design and technical specifications are subject to change without notice.			

Technical Specifications

Specifications	Models		
	iQ751, Gen II	iQ1001, Gen II	iQ1501, Gen II
Features and Approvals			
4-Unit Cascaded High Turn Down	100:1	133:1	200:1
Built-In Redundancy	Multiple Heat Exchangers with Individual Control		
Cascading	Masterless, 4-Unit, Automatic Rotation		
Common Venting	Yes, Up to 4 Units		
Heat Exchanger	Expandable, Stainless 316L		
Appliance Certification to ANSI Z21.10.3	ETL		
SCAQMD	Ultra Low Nox (under 20 PPM)		
ASME	HLW		
Performance GPM	iQ751, Gen II	iQ1001, Gen II	iQ1501, Gen II
Hot Water Capacity, 45°F Rise (GPM)	31.4	41.6	64.3
Hot Water Capacity, 70°F Rise (GPM)	20.2	26.7	41.3
Hot Water Capacity, 90°F Rise (GPM)	15.7	20.8	32.1
Hot Water Capacity, 100°F Rise (GPM)	14.1	18.7	28.9
Hot Water Capacity, 140°F Rise (GPM)	10.1	13.4	20.7
Warranty	Heat Exchanger Coil – 10 years, All Other Parts – 2 years		
Note: Due to Intellihot's policy of continuous product improvements the design and technical specifications are subject to change without notice.			

3.2 High Elevation Installations

For operation at elevations above 2,000 feet, the hot water delivery capacity should be reduced by 4% for each 1,000 feet above sea level.

3.3 Clearance Requirements

In order for the water heater to operate properly and efficiently, the clearances specified in the table below are required.

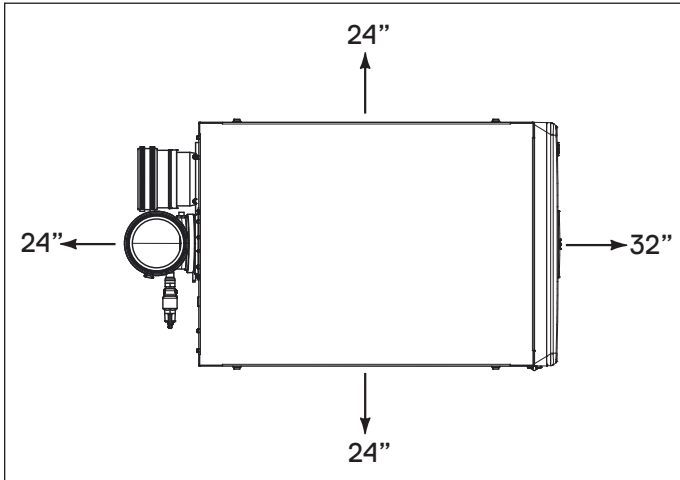

Service Clearances. If multiple units are installed, the side clearance can be shared between the two units.

Location	Required		Recommended
	From Combustibles	From Non-Combustibles	
Top	6" (15.2 cm)	2" (50.8 cm)	18" (46 cm)
Back	5/8" (15.8 mm)	5/8" (15.8 mm)	24" (61 cm)
Sides	1" (25.4 mm)	1/2" (12.7 mm)	24" (61 cm)
Front	2" (5.1 cm)	2" (5.1 cm)	32" (81 cm)
Bottom	0" (0 mm)	0" (0 mm)	0" (0 mm)

¹ Service clearances are required dimensions to allow for normal service of the unit.

3.4 Connection Specifications

Connections	
Description	Specification ²
Gas Supply Inlet Connection	1-1/4" NPT Flange Connection
Water Supply Inlet Connection	2" Flange Connection
Heated Water Outlet Connection	2" Flange Connection
Exhaust Gas Vent ¹	6" Polypropylene
Air Intake Inlet ¹	6" Polypropylene
Condensate Drain Connection	3/4"
Power Supply	120V AC Power

¹ Use the 6" adapter provided when using PVC or CPVC pipe.

² Using sizes other than specified can cause damage to the water heater and will void the warranty.

3.5 Exhaust Gas Nominal values

CO ₂ and CO Standards		
Description	CO ₂ Range (%)	Max. CO Level (ppm)
Natural Gas		
High Fire	9.1% to 9.3%	< 200 ppm
Low Fire	9.1% to 9.3%	< 60 ppm
Propane Gas		
High Fire	10.1% to 10.5%	< 200 ppm
Low Fire	10.1% to 10.5%	< 60 ppm

3.6 Overall Dimensions

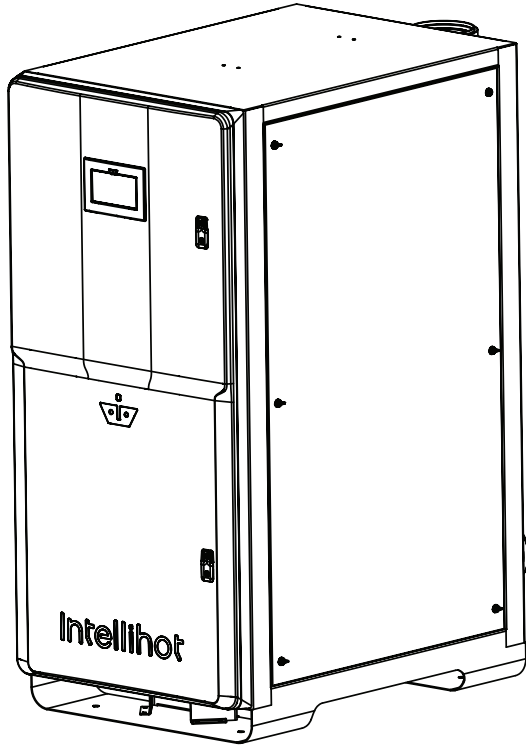

iQ751 | iQ1001 | iQ1501

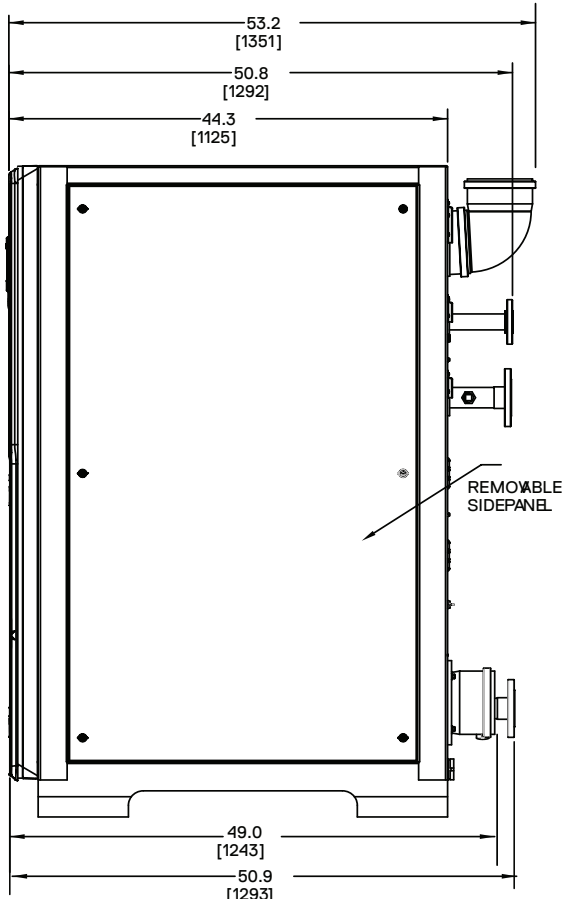
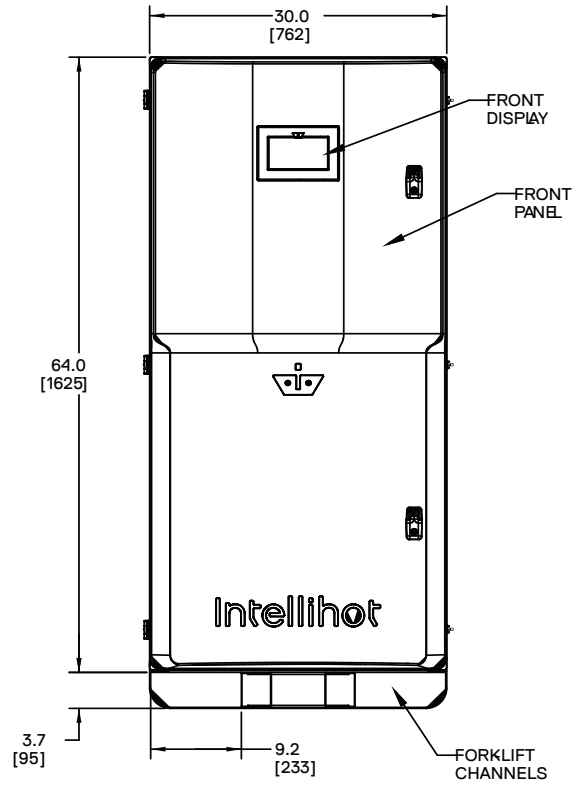

iQ751 | iQ1001

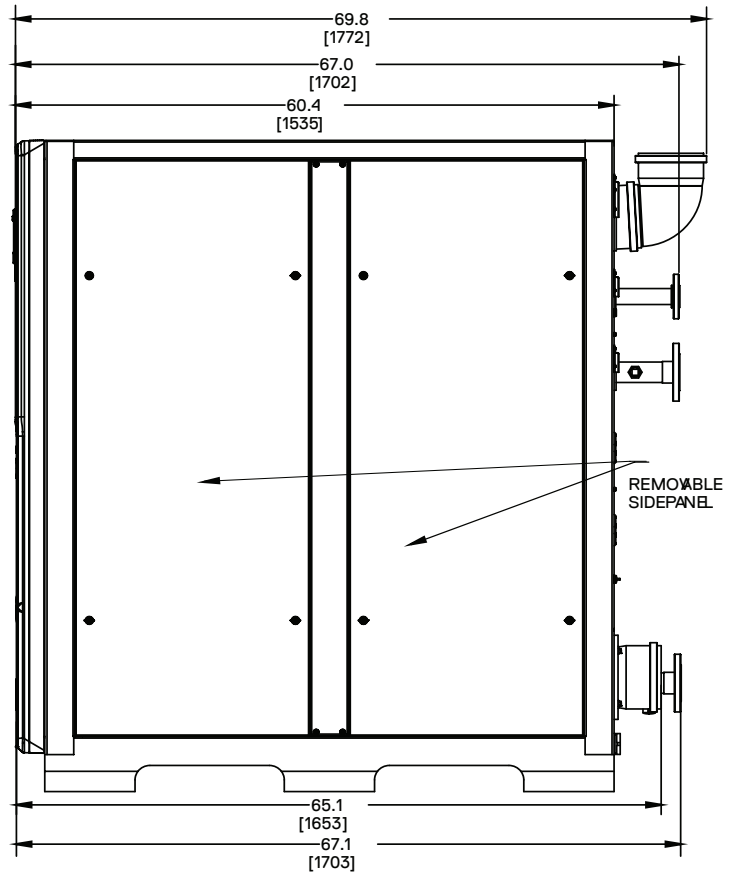

iQ1501

All dimensions are in Inches, and equivalent metric values are specified within []

iQ751 | iQ1001 | iQ1501

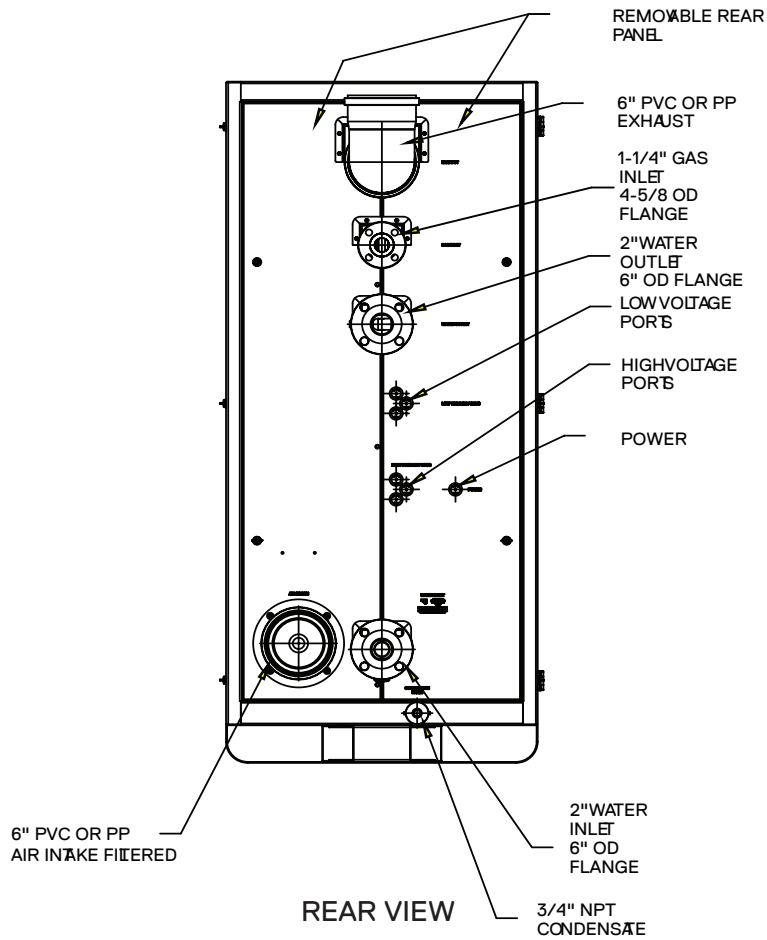

iQ751 | iQ1001

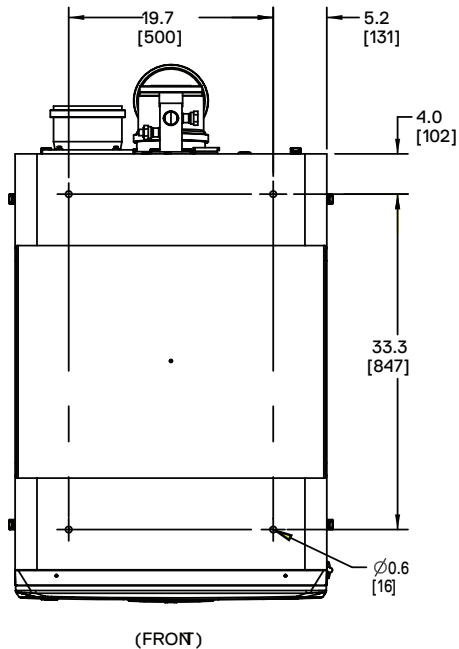

iQ1501

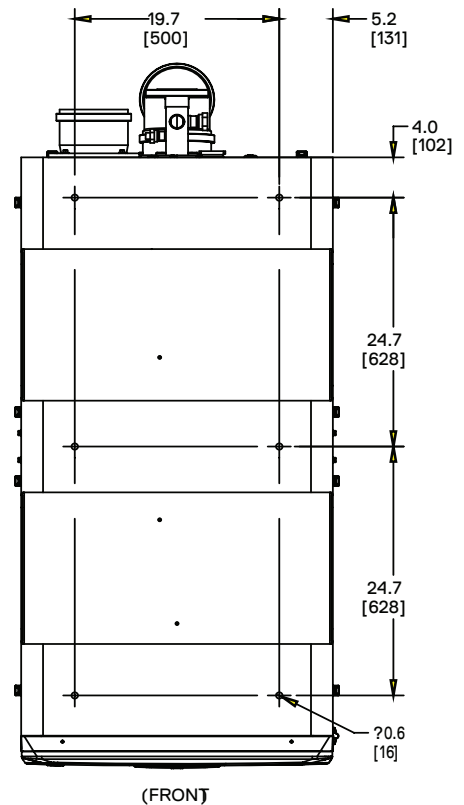

BOTTOM VIEW

All dimensions are in Inches, and equivalent metric values are specified within [].

3.7 Configuration Options

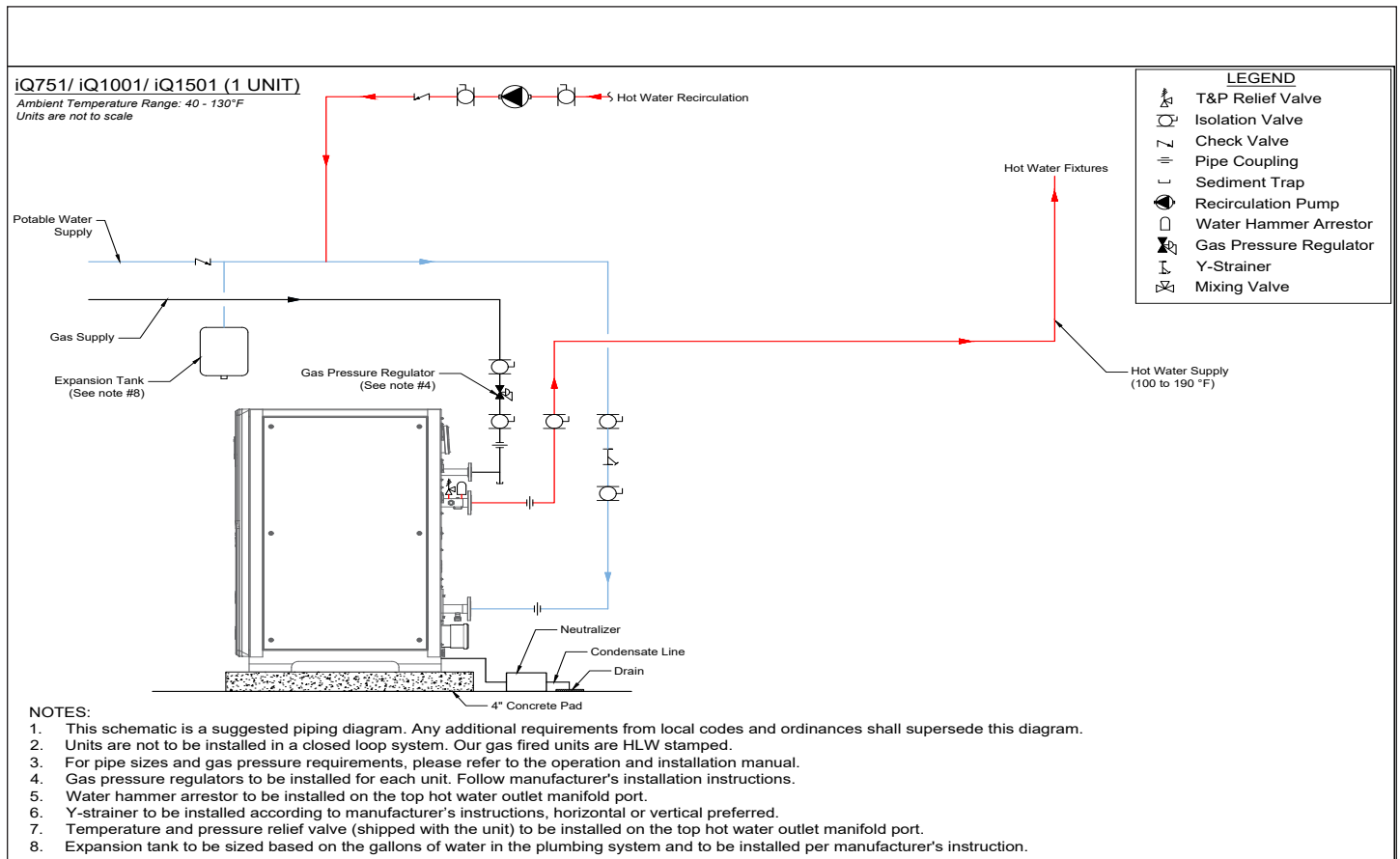

System with no storage tank and without mixing valve.

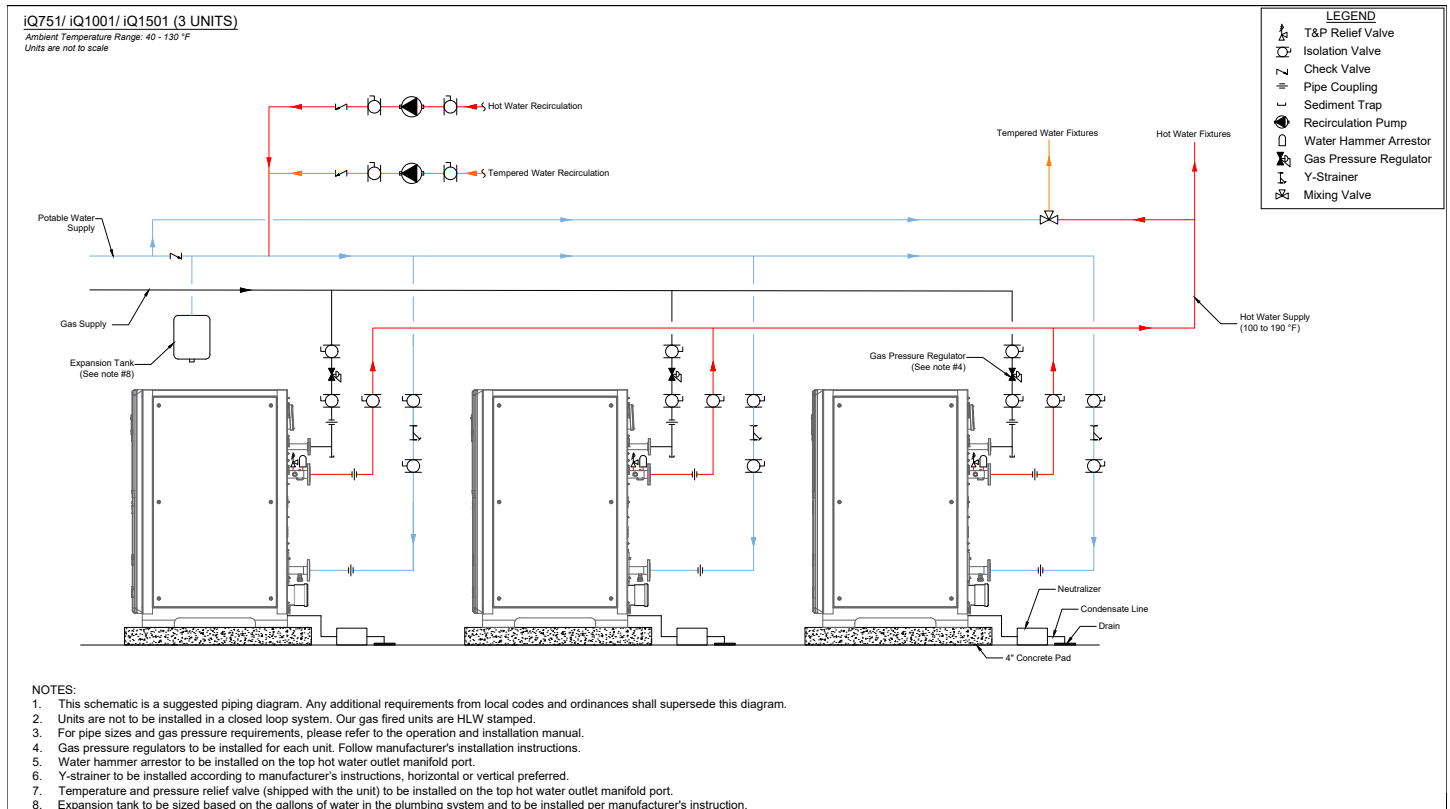

Multiple unit system with mixing valve but no storage tank.

4. Quick Reference Installation Guide

4.1 Install the Water Heater

When installing the water heater, follow all local building codes and the current edition of the National Fuel Gas Code (ANSI Z223.1/NFPA 54) in the USA, or National Gas and Propane Installation Code (CAN/CGA B149.1) in Canada.

Note: For water heater installations in Massachusetts, refer to section, "17. Requirements for State of Massachusetts" on page 77.

1. Select an installation location
For an interior or exterior location refer to section "5. Preparation Before Installation" on page 16.
2. Check the quality of the water to determine if additional treatment would be beneficial to the function and efficiency of the water heater. For additional information refer to section "5. Preparation Before Installation" on page 16.
3. Make all necessary gas connections.
For additional information refer to section "6. Gas Connection" on page 18.
4. Make all necessary venting connections.
For additional information refer to section "7. Air Intake Inlet and Exhaust Gas Outlet Pipe Connections" on page 23.
5. Make all necessary water connections.
For additional information refer to section "8. Water Connections" on page 33.
6. Make all necessary electrical connections.
"9. Electrical Power" on page 37.

Note: For additional electrical protection, the use of a surge protection device is recommended. Damage caused by power surges is not covered by the warranty.

7. If necessary, convert the water heater from the factory preset of using natural gas to using propane. Refer to "11. Natural Gas to Propane Conversion" on page 42 for the required instructions.
 - a. Propane conversion must be done within the 72 hours of the water being turned ON for heating the water.

DANGER

Improper propane conversion or not performing the conversion within the 72 hours could cause property damage, serious injury, or even death.

8. As part of the propane conversion process, the CO₂ and CO values must be adjusted. This process is also required when installing the water heater at altitudes over 8,000 feet. This procedure should be performed only by a qualified technician. To check and/or adjust the CO₂ and CO levels, refer to "10. Adjusting CO₂ Level" on page 38.
9. If connecting multiple units together, refer to "13. Connecting Multiple Units" on page 51.
10. Fill out the Warranty Card and return it to Intellihot. For a copy of the card go to "19. Product Warranty" on page 81.

4.2 Pre-Startup Instructions

1. Recheck the hot and cold water lines, the gas line, condensate drain line, the fresh air inlet, and exhaust vent to make sure they are properly connected.

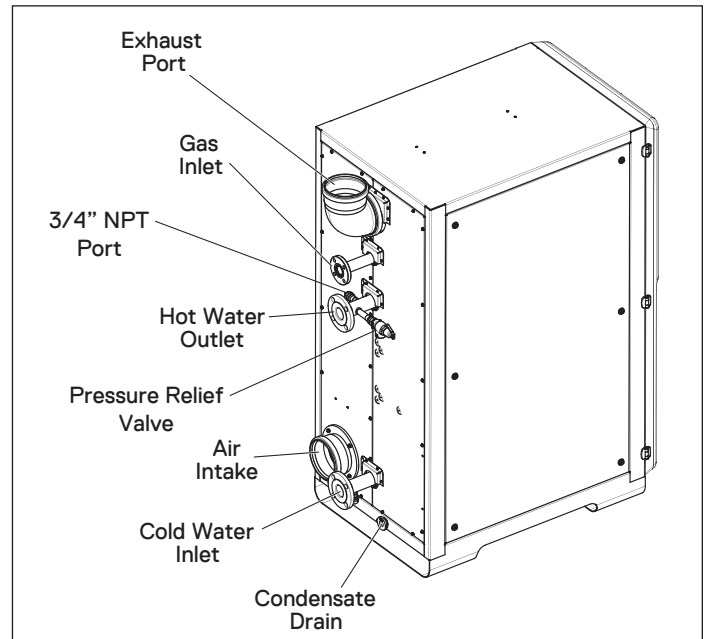

2. Open the gas supply valve, cold water valve, and hot water valve.

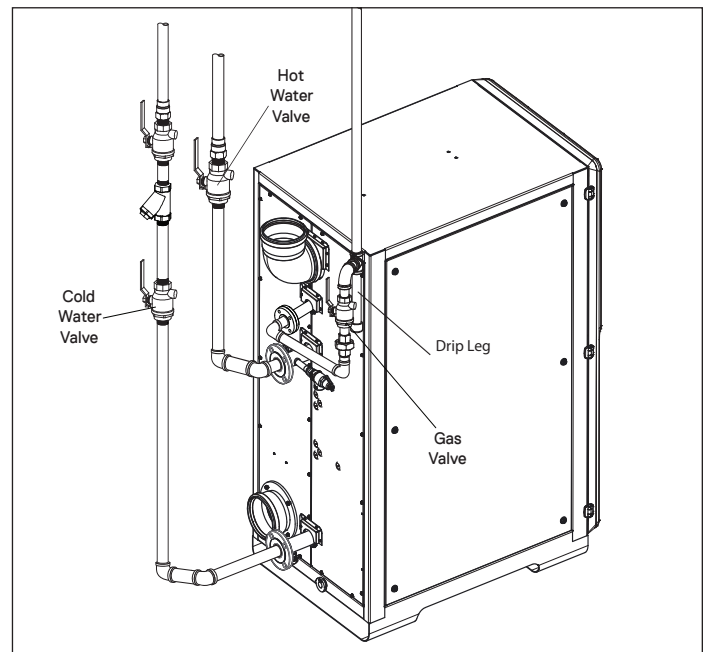

3. Before beginning this procedure, be sure power to the unit is off. Open several faucets and fixtures to allow for the maximum water flow rate.
4. Slowly open the outlet isolation water valve.
5. Slowly open the inlet isolation water valve.
6. Allow water to run for 10 minutes to purge all the air from the system

7. Slowly close the outlet isolation valve.
8. Purge air from the pump by opening its bleed screw.
9. Open the T&P valve to eliminate any residual air from the system. Purge for 5 minutes.
10. The pump fuses are removed and placed inside a plastic bag when the unit is shipped. This bag is located inside the front door (as shown below). The pump and the fuse holder are located on the right-hand side of the unit. Please open the right-hand side panels and insert the fuses onto the pump fuse holder.
16. Follow the instructions in this manual and on the unit's display screen. For additional information refer to section "12. Operation" on page 44.
17. If multiple units are being installed, follow these instructions for each unit.

⚠ DANGER

Please make sure to shut off the power at the breaker before installing the fuses.



11. Turn ON the power switch at the electrical junction box and turn ON the ON/OFF switch inside the front cabinet door. The water heater's display panel should turn ON.

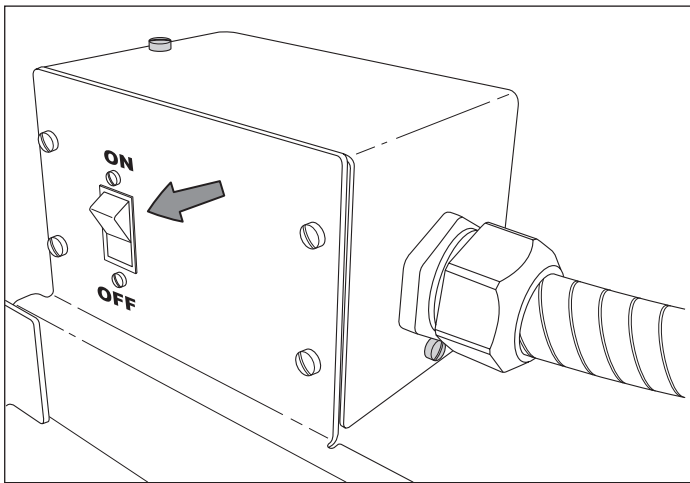

12. Slowly reopen the outlet isolation valve to allow maximum flow of water.
13. Ensure the unit is operational and running at high fire with all individual engines operational.
14. Let the unit run a high fire for 15 minutes.
15. Turn off all the open faucets.

5. Preparation Before Installation

5.1 Selecting an Indoor Installation Site

Note: When installing the water heater, follow all local building codes and the current edition of the National Fuel Gas Code (ANSI Z223.1/NFPA 54) in the USA, or National Gas and Propane Installation Code (CAN/CGA B149.1) in Canada when installing this product.

Note: For water heater installations in Massachusetts, refer to section “17. Requirements for State of Massachusetts” on page 77.

1. Select an interior location for the installation. Each installation is unique; therefore, take the time to find the best location for the water heater.
 - a. Install the water heater near locations that use hot water, such as bathroom, kitchen, or laundry room faucets.
 - b. Select a location that minimizes the length of the water pipe.
 - c. If the distances are long or if the faucet or appliance requires “instant” hot water, we recommend running a recirculation line back to the water heater from the farthest fixture.
 - d. Insulate the hot water supply and recirculation lines.
 - e. Select a location away from foot traffic and away from areas where dust, debris, chemical agents, or other combustible materials could accumulate.
 - f. Allow sufficient space for service and maintenance access to all gas, water, and drain connections.
 - g. Make sure the location meets all building code requirements.
2. Minimize the distance that the exhaust gas outlet and air intake inlet must travel to an exterior wall.
 - a. The exhaust vent outlet must not be located next to a walkway, near soffit vents, crawl space vents, or other areas where condensate (water vapor) could cause damage or create a hazard. Refer to the Venting Clearance Specifications section for additional information.
 - b. The fresh air inlet vent must be separated from the exhaust vent per guidelines in section “7. Air Intake Inlet and Exhaust Gas Outlet Pipe Connections” on page 23.
 - c. Contaminated or dirty air drawn into the intake pipe can damage the water heater. The warranty does not cover damage caused by airborne contaminants.
3. Locate the unit close to a drain and near gas and water connections.

The water heater produces a significant amount of condensate during normal operation and should be located near a suitable drain where damage from a possible leak will be minimal. Installing the water heater in a location without a drain will void the warranty and the manufacturer will not be responsible for any resulting water damages that may occur. For additional information, refer to the Condensate Line Installation

4. Locate the water heater and all the water pipes in an area where the ambient temperature always remains above freezing.
 - a. When the water heater is connected to an electrical power supply, it will automatically prevent the water from freezing inside the unit..

NOTICE

In cold climates, if there is a power failure, the unit's freeze protection system will not operate and can result in water freezing inside the heat engine. To prevent damage to the water heater, turn OFF the gas supply and inlet water valve. Drain the unit completely. Damage caused by freezing water is not covered by the warranty.

5. Select an appropriate location for the combustion air and exhaust pipes to exit the building, as shown in the Venting Clearance Specifications section in this manual.

NOTICE

Make sure to close the side panels. Component failures due to improper closing of the cabinets are not covered by warranty.

6. Check the water quality. Proper maintenance of the water heater is required to ensure that the water meets EPA quality standards. The following table shows the maximum contaminant levels allowed, based on the EPA National Secondary Drinking Water Regulations (40 CFR Part 143.3). Refer to section “18. Warranty” on page 78 for additional information.

If you suspect that your water is contaminated in any way, discontinue use of the water heater and contact an authorized technician or licensed professional.

If the incoming water is known to have a high mineral content or “hardness” (see warranty section), treatment is recommended upstream from the water heater.

7. After all the work is done, install the side panels and make sure it's fully closed all the time. Keeping the side panels would cause dirt build on the blower and reduced blower life. Warranty requests will not be honored.

5.2 Selecting an Outdoor Installation Site

Note: When installing the water heater, follow all local building codes and the current edition of the National Fuel Gas Code (ANSI Z223.1/NFPA 54) in the USA, or National Gas and Propane Installation Code (CAN/CGA B149.1) in Canada when installing this product.

Note: For water heater installations in Massachusetts, the unit must be installed by a plumber or gas-fitter licensed within the Commonwealth of Massachusetts. Refer to the Requirements for the State of Massachusetts section in this manual for additional information.

1. Select a location for the installation. Each installation is unique; therefore, take the time to find the best location for the water heater. Select a location that minimizes the length of the water pipe.
 - a. Select a location that minimizes the length of the water pipe.
 - b. If the distances are long or if the faucet or appliance requires “instant” hot water, we recommend running a recirculation line back to the water heater from the farthest fixture.
 - c. Insulate the hot and cold water supply and recirculation lines to prevent freezing or hot surface danger.
 - d. Select a location away from foot traffic and away from areas where dust, debris, chemical agents, or other combustible materials could accumulate.
 - e. Allow sufficient space for service and maintenance access to all gas, water, and drain connections.
 - f. Make sure the location meets all building code requirements.
 - g. Contaminated or dirty air drawn into the intake pipe can damage the water heater. The warranty does not cover damage caused by airborne contaminants.
 - h. Ensure that the air intake is free (and remains free) from grass clippings, wood, landscaping and other debris. It must be higher than the code defined snow line.

2. Locate the unit close to a drain and near gas and water connections.

The water heater produces a significant amount of condensate during normal operation and should be located near a suitable drain where damage from a possible leak will be minimal. If installing on a the water heater in a location without a drain will void the warranty and the manufacturer will not be responsible for any resulting water damages that may occur. For additional information, refer to the Condensate Line Installation section.

3. Locate the water heater and all the water pipes in an area where they can be properly insulated.
 - a. When the water heater is connected to an electrical power supply, it will automatically prevent the water from freezing inside the unit.

NOTICE

If there is a power failure, the unit's freeze protection system will not operate and can result in water freezing inside the heat engine. To prevent damage to the water heater, turn OFF the gas supply and inlet water valve. Completely drain the unit. Damage caused by freezing water is not covered by the warranty.

6. Gas Connection

WARNING

FIRE AND/OR EXPLOSION HAZARD

To avoid serious injury or even death, the gas line installation and the gas line inlet pressure test must be done by a licensed professional.

Always match the water heater with the type of gas supplied to the unit (natural gas or propane). The water heater is factory preset for natural gas.

Make sure the gas line pressures are within normal limits. Pressures outside normal limits can result in poor performance and hazardous operating conditions.

6.1 Quick Reference Installation Instructions

1. Determine fuel source; natural gas or propane as shown in “6.2 Fuel Source” on page 18.
2. Measure gas pressure as shown in “6.3 Gas Pressure Requirements” on page 18.
3. Install a gas pressure regulator and vent line if gas pressure is above maximum recommendations as shown in “6.4 Gas Pressure Regulator” on page 18.
4. Measure the length of the supply line as shown in “6.5 Length of Gas Supply Line” on page 19”.
5. Select the proper gas piping material as shown in “6.5 Length of Gas Supply Line” on page 19.
6. Select the proper gas piping diameter as shown in “6.7 Determine Correct Gas Pipe Diameter” on page 19.
7. Install a drip leg on the gas piping as shown in “6.8 Gas Pipe Drip Leg and Shut-off Valve” on page 19.
8. Install a manual shut-off valve as shown in “6.8 Gas Pipe Drip Leg and Shut-off Valve” on page 19.
9. Test all gas line connections for leaks.

NOTICE

Do not fire (operate) the water heater until all connections have been completed and the heat engine is filled with water.

6.2 Fuel Source

1. Natural gas is the factory preset.
2. To convert the unit to propane, refer to the Propane (LPG) Conversion section in this manual.
3. Propane conversion must be done within the 72 hours of the water heater being turned ON for heating the water

DANGER

Improper propane conversion or not performing the conversion within the 72 hours could cause property damage, serious injury, or even death.

6.3 Gas Pressure Requirements

iQ series water heaters are designed to operate at gas pressures as low as 2.5” WC (at maximum firing rate). Gas inlet pressures to each unit should not exceed 14” WC under any condition (when unit is firing or not firing).

Natural Gas Static Gas Pressure	
Parameters	Specifications
Minimum Static Gas Pressure	2.5” W.C. (non-corrugated, black iron)
Recommended Static Gas Pressure	8” W.C.
Maximum Static Gas Pressure	14” W.C.

6.4 Gas Pressure Regulator

1. If the gas inlet pressure is higher than recommended, install a gas pressure regulator to lower gas pressure to an acceptable level.
2. The gas pressure regulator must have the same or higher minimum to maximum modulation range as the iQ model it is regulating. For example, an iQ1001 gas pressure regulator should have a modulation range of 30,000 BTU/h to 1,001,000 BTU/h.
3. When multiple units are connected use a dedicated gas pressure regulator for each unit.
4. Regulators required to be mounted with a minimum of 12” of straight length pipe on either side and a recommended a min. of 6 ft from appliance. If regulator manufacturer recommends more distance, then follow their guidelines.

6.4.1 Venting of Gas Supply Regulators

Make sure the gas supply regulator is properly vented by following all local codes and the gas regulator manufacturer’s recommendations.

1. The vent pipe must be at least the same size as the regulator vent.
2. When multiple units are connected, each regulator must have a separate vent line.
3. Vent lines must not be connected together or connected with any other appliance requiring external venting.
4. When selecting the size, the pipe diameter must be increased by one size for every 20 feet of pipe.
 - a. Each 90° elbow is equivalent to approximately:
4.5 feet for nominal pipe sizes of up to 1-1/2”
10.5 feet for nominal pipe sizes of up to 4”.
 - b. Each 45° elbow is equivalent to approximately:
2 feet for nominal pipe sizes of up to 1-1/2”
5 feet for nominal pipe sizes of up to 4”.

6.5 Length of Gas Supply Line

1. Make sure the length supply line is correctly sized.
 - a. Measure the length of the gas supply line from the gas meter to the water heater or other appliances requiring gas. The diameter of the pipe must be in relation to the length.
 - b. The total length of gas piping, as well as fitting pressure drop, must be considered when sizing the gas piping. Total equivalent length should be calculated from the meter or source location to the last heater connected.
 - c. Gas pipe size should be selected on the total equivalent length. The gas volume for cfh flow will be the input divided by the calorific value of the fuel to be supplied.
 - d. Use the Gas Pipe Sizing tables in this manual or refer to the gas line manufacturers sizing information to determine the correct diameter for the supply pipe.
 - e. The diameter of the gas lines, shown in the illustration, will vary according to the specific installation requirements.

6.6 Gas Piping Material

1. All gas piping and components must comply with NFPA local codes, and utility requirements minimum. Only gas approved fittings, valves, or pipe should be utilized.
2. Standard industry practice for gas piping is Schedule 40 iron pipe and fittings. All high and low gas pressure piping systems must comply with local utility and building codes.
3. Assembled piping should be clean of all scale, debris, metal particles, or foreign material.
4. The piping must be supported from the floor, ceiling, or walls and by the water heater itself.

6.7 Determine Correct Gas Pipe Diameter

Note: The water heater should be the first appliance to be connected to the gas supply line.

1. Determine the gas requirement of the water heater(s) and other appliances requiring gas.
2. Size the pipe diameter according to the COMBINED total maximum BTUH volume for all the appliances as if they were all operating at the same time. Use the “6.10 Gas Pipe Sizing Tables” on page 21.
3. Select the proper header pipe according to the number of units being connected together, as shown in the chart.

Header Sizing for Multiple iQ Units				
Number of Heaters	1	2	3	4
Sch 40 Iron Pipe	2"	2"	3"	3"

4. The maximum pressure drop from the source to the final water heater must not exceed 0.3" W.C.

5. The maximum gas flow rate required is the sum of the maximum inputs of each unit divided by the heat of combustion of the fuel supplied at the location, (approximately 1,030 BTU per cubic foot for natural gas or 2,520 BTU per cubic foot for propane).

Note: The fuel supplier or utility should be consulted to confirm that sufficient volume and normal pressure is provided to the building at the discharge side of the gas meter or supply pipe.

6.8 Gas Pipe Drip Leg and Shut-off Valve

1. Install a gas pipe drip leg on each water heater to prevent dirt, condensation, or debris from entering the gas inlet.

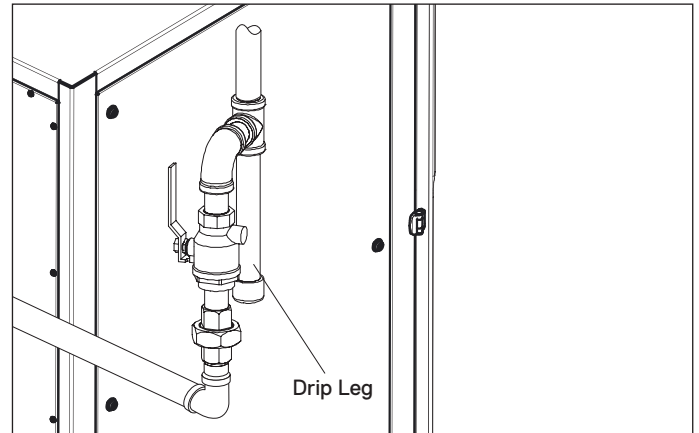

2. Local codes may require multiple units to have a full size drip leg on the main gas supply line and one on each unit.
3. The drip leg should have a removable clean-out cap.
4. The gas pipe must not be supported by the drip leg.
5. Following local building codes when selecting and installing a shut-off valve.
6. Local codes may require multiple units to have a shut-off valve on the main gas supply line and one on each unit.

⚠ DANGER

The drip leg is required to protect the gas valve from debris and metal shavings. If the local plumbing code does not allow drip leg, an alternative mechanism such as filter shall be installed to protect the gas valve. The warranty does not cover if the gas valve is stuck open due to missing drip leg (or not including alternative method).

6.9 Connecting Gas Line to Unit

Note: Always clean the inside of the gas line of any dirt or debris before connecting the piping to the unit.

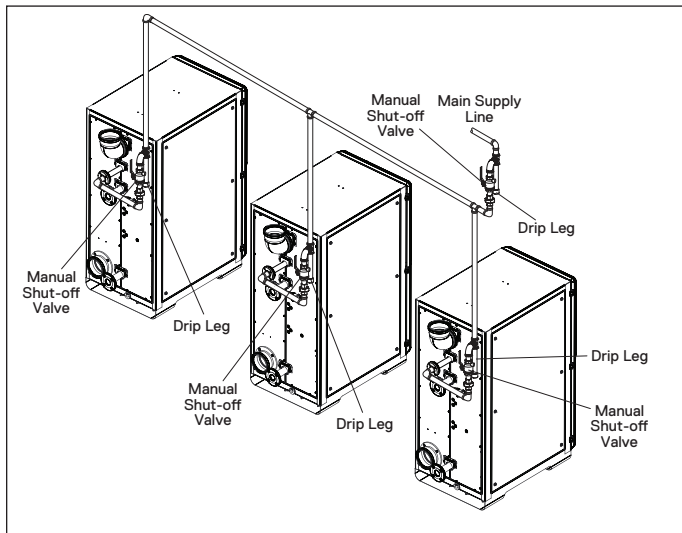
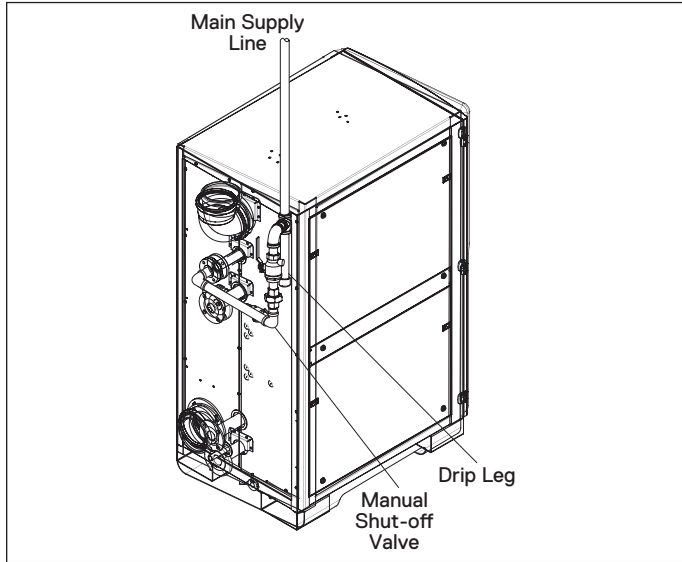

1. Install a 4-5/8" OD flanged steel coupling and gasket with a short piece of 1-1/4" NPT black pipe.

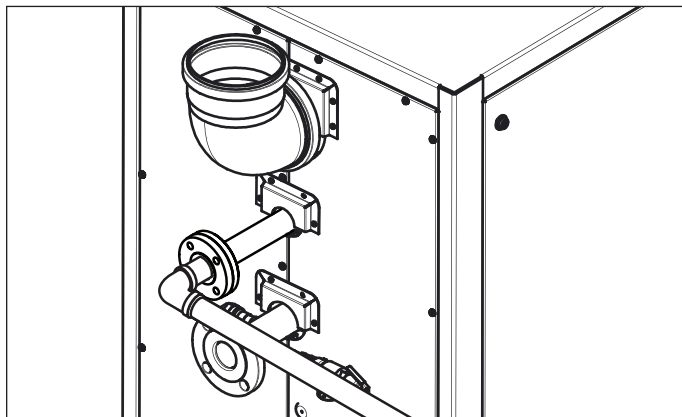

2. Install a manual shut-off valve as described in "6.8 Gas Pipe Drip Leg and Shut-off Valve" on page 19

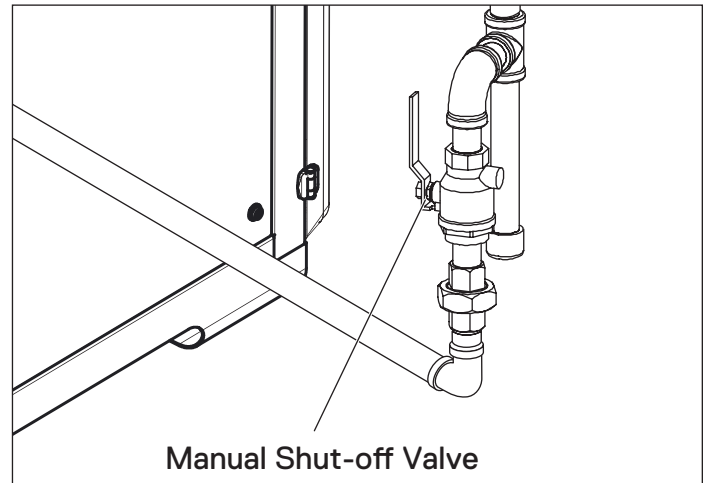

3. Install a drip leg in "6.8 Gas Pipe Drip Leg and Shut-off Valve" on page 19.
4. Continue installing pipe to reach the main gas supply connection.
5. Test all gas pipe connections.
 - a. All the gas pipe connections should be tested as prescribed in NFPA 54.
 - b. In multiple unit applications, each unit should be isolated before testing any piping system may exceed the allowable pressure of 14.0" W.C..

NOTICE

Do not fire (operate) the water heater until all connections have been completed and the heat engine is filled with water.

6.10 Gas Pipe Sizing Tables

This information is for reference only. Refer to gas pipe manufacturer specifications for actual delivery capacity. Contact the local gas supplier for actual BTU/ft³ rating. This data copied from the National Fire Protection Association Article 54 (NFPA 54).

Pipe Sizes and BTU/h Capacity (NATURAL GAS). Use this table for static gas pressure LESS THAN 5" W.C.								
Length including fittings (feet)	3/4"	1"	1-1/4"	1-1/2"	2"	2-1/2"	3"	4"
10	360,000	678,000	1,390,000	2,090,000	4,020,000	6,400,000	11,300,000	23,100,000
20	247,000	466,000	957,000	1,430,000	2,760,000	4,400,000	7,780,000	15,900,000
30	199,000	374,000	768,000	1,150,000	2,220,000	3,530,000	6,250,000	12,700,000
40	-	320,000	657,000	985,000	1,900,000	3,020,000	5,350,000	10,900,000
50	-	284,000	583,000	873,000	1,680,000	2,680,000	4,740,000	9,660,000
60	-	257,000	528,000	791,000	1,520,000	2,430,000	4,290,000	8,760,000
70	-	237,000	486,000	728,000	1,400,000	2,230,000	3,950,000	8,050,000
80	-	220,000	452,000	677,000	1,300,000	2,080,000	3,670,000	7,490,000
90	-	207,000	424,000	635,000	1,220,000	1,950,000	3,450,000	7,030,000
100	-	-	400,000	600,000	1,160,000	1,840,000	3,260,000	6,640,000
125	-	-	355,000	532,000	1,020,000	1,630,000	2,890,000	5,890,000
150	-	-	322,000	482,000	928,000	1,480,000	2,610,000	5,330,000
175	-	-	296,000	443,000	854,000	1,360,000	2,410,000	4,910,000
200	-	-	275,000	412,000	794,000	1,270,000	2,240,000	4,560,000

Note: BTU/h capacities are based on specific gravity of 0.6, pressure drop of 0.5" WC

Pipe Sizes and BTU/h Capacity (NATURAL GAS). Use this table for static gas pressure GREATER THAN 5" W.C.									
Length including fittings (feet)	1/2"	3/4"	1"	1-1/4"	1-1/2"	2"	2-1/2"	3"	4"
10	404,000	949,000	1,787,000	3,669,000	5,497,000	10,588,000	16,875,000	29,832,000	43,678,000
20	286,000	652,000	1,228,000	2,522,000	3,778,000	7,277,000	11,598,000	20,503,000	30,020,000
30	233,000	524,000	986,000	2,025,000	3,034,000	5,844,000	9,314,000	16,465,000	24,107,000
40	202,000	448,000	844,000	1,733,000	2,597,000	5,001,000	7,971,000	14,092,000	20,632,000
50	-	397,000	748,000	1,536,000	2,302,000	4,433,000	7,065,000	12,489,000	18,286,000
60	-	360,000	678,000	1,392,000	2,085,000	4,016,000	6,401,000	11,316,000	16,569,000
70	-	331,000	624,000	1,280,000	1,919,000	3,695,000	5,889,000	10,411,000	15,243,000
80	-	308,000	580,000	1,191,000	1,785,000	3,437,000	5,479,000	9,685,000	14,181,000
90	-	289,000	544,000	1,118,000	1,675,000	3,225,000	5,140,000	9,087,000	13,305,000
100	-	273,000	514,000	1,056,000	1,582,000	3,046,000	4,856,000	8,584,000	12,568,000
125	-	242,000	456,000	936,000	1,402,000	2,700,000	4,303,000	7,608,000	11,139,000
150	-	219,000	413,000	848,000	1,270,000	2,446,000	3,899,000	6,893,000	10,093,000
175	-	202,000	380,000	780,000	1,169,000	2,251,000	3,587,000	6,342,000	9,285,000
200	-	-	353,000	726,000	1,087,000	2,094,000	3,337,000	5,900,000	8,638,000

Note: For 1/2" line BTU/h capacities are based on specific gravity of 0.6, pressure drop of 4.6" WC and 5.0" WC. For all other line sizes, capacities are based on specific gravity of 0.6, pressure drop of 3.0" WC

Pipe sizes and BTU/h capacity (PROPANE). Use this table for static gas pressure GREATER THAN 5" W.C.									
Length including fittings (feet)	1/2"	3/4"	1"	1-1/4"	1-1/2"	2"	2-1/2"	3"	4"
10	409,000	608,000	1,150,000	2,350,000	3,520,000	6,790,000	10,800,000	19,100,000	39,000,000
20	289,000	418,000	787,000	1,620,000	2,420,000	4,660,000	7,430,000	13,100,000	26,800,000
30	236,000	336,000	632,000	1,300,000	1,940,000	3,750,000	5,970,000	10,600,000	21,500,000
40	204,000	287,000	541,000	1,110,000	1,660,000	3,210,000	5,110,000	9,030,000	18,400,000
50	-	255,000	480,000	985,000	1,480,000	2,840,000	4,530,000	8,000,000	16,300,000
60	-	231,000	434,000	892,000	1,340,000	2,570,000	4,100,000	7,250,000	14,800,000
80	-	212,000	400,000	821,000	1,230,000	2,370,000	3,770,000	6,670,000	13,600,000
100	-	-	372,000	763,000	1,140,000	2,200,000	3,510,000	6,210,000	12,700,000
125	-	-	349,000	716,000	1,070,000	2,070,000	3,290,000	5,820,000	11,900,000
150	-	-	330,000	677,000	1,010,000	1,950,000	3,110,000	5,500,000	11,200,000
175	-	-	292,000	600,000	899,000	1,730,000	2,760,000	4,880,000	9,950,000
200	-	-	265,000	543,000	814,000	1,570,000	2,500,000	4,420,000	9,010,000
Note: The line BTU/h capacities are based on specific gravity of 1.5, pressure drop of 0.5" WC.									

7. Air Intake Inlet and Exhaust Gas Outlet Pipe Connections

⚠ DANGER

Improper venting of the water heater will result in excessive levels of carbon monoxide, which can lead to severe personal injury or death. This water heater must be vented in accordance with the “Venting of Equipment” section of the latest edition of the ANSI Z223.1 / NFPA 54 (Natural Fuel Gas Code) in the USA, or in Canada refer to the “Venting Systems and Air Supply for Appliances” section in the latest version of CAN/CGA B149.1 (Natural Gas and Propane Installation Code), and all applicable local building codes. Vent installation should be performed only by a licensed professional.

⚠ WARNING

**BREATHING HAZARD
CARBON MONOXIDE GAS**

- Do not operate flood damaged water heaters.
- Install venting system according to the required codes and material manufacturers specifications.
- Do not obstruct fresh air intakes or exhaust outlets. Adequately support all vent system piping.
- Do not place vapor emitting products near water heater or air intake.
- Place working carbon monoxide detectors outside each sleeping area.
- Do not operate the water heater before properly installing the exhaust outlet.
- Visually inspect the vent system and eliminate any possible area where condensation could create a blockage of intake or exhaust air.

Breathing concentrated levels of carbon monoxide, even for a short period of time, will cause brain damage and can even lead to death.

Note: This water heater falls into the Category IV appliance.

7.1 Quick Reference Installation Guide

1. Select the desired type of venting system: Two Pipe Vent System (Direct) or Single Pipe Vent System (Power).

“7.3 Two Pipe Vent System (Direct Vent)” on page 25.

“7.4 Single Pipe Venting System (Power Vent)” on page 27.

2. Select the desired termination of the air intake inlet and exhaust gas outlet pipe; outside wall or roof.

“7.3.3 Side Wall Air Intake Inlet and Exhaust Gas Outlet Pipe Termination” on page 26.

“7.3.4 Roof Air Intake Inlet and Exhaust Gas Outlet Pipe Termination” on page 26.

3. Determine the straight line distance and the number of elbows required to route the air intake inlet and exhaust gas outlet pipes to their termination point.
“7.6 Intake Air Inlet and Exhaust Gas Outlet Pipe Diameter and Length” on page 28.
4. Determine the diameter of pipe required to properly bring in intake air and vent exhaust gas.
“7.6 Intake Air Inlet and Exhaust Gas Outlet Pipe Diameter and Length” on page 28.
5. Verify the location of the air intake inlet and exhaust gas outlet terminations are within state and local codes.
“7.7 Venting Clearance Specifications” on page 29.
6. Select an approved material for the air intake inlet piping.
“7.8 Exhaust Gas Outlet Pipe Materials” on page 30.
7. Select an approved material for the exhaust gas outlet piping.
“7.9 Air Intake Inlet Pipe Vent Materials” on page 30.

7.2 Typical Single Unit Air Intake Inlet and Exhaust Gas Outlet Pipe Installation

1. Select one of the two venting configurations: two pipes (direct vent) configuration or with one pipe (power vent) configuration.

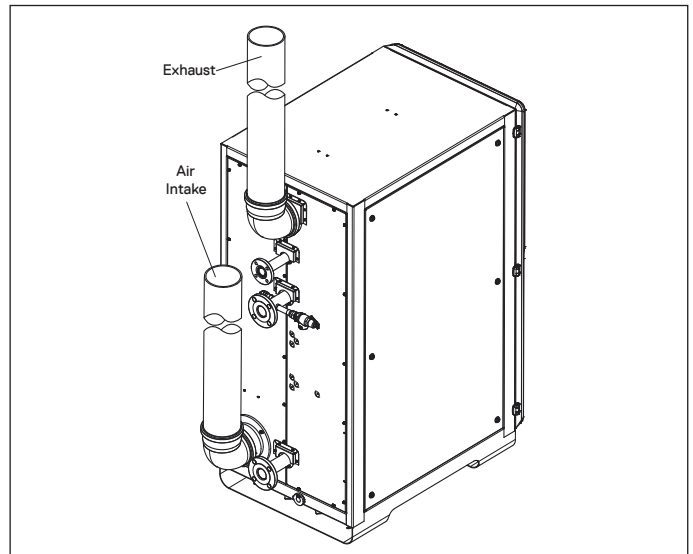

2. Select the desired termination location and make sure each pipe terminates within all local and state codes.
3. Select the desired material for the air intake inlet and exhaust gas outlet pipes.

⚠ CAUTION

This water heater has a factory preset control to limit the exhaust gas temperature to 149°F (65°C) when the PVC is selected in the “Flue Type” programming section. As a result, the water heater can be vented with Schedule 40 PVC. If the incoming (or recirculation return) water temperature does not exceed 150°F (66°C), the exhaust gas temperature will not exceed 149°F (65°C).

⚠ WARNING

When the unit is set for CPVC (polypropylene pipe), flue temperatures can reach 190°F (88°C). PVC pipe will melt at temperatures above 149°F (65°C) and could therefore result in a fire. Make sure the setting and the type of material being used for the flue are compatible.

For this application use Schedule 80 CPVC or Approved Polypropylene in the USA or Type BH Special Gas Vent Class IIB (CPCV) or Class IC (Polypropylene) that conforms to ULC-S636 in Canada.

Note: If PVC or CPVC pipe is being used, the included polypropylene-to-PVC adapters must be installed. Please refer to section 7.11 for adaptor orientation and angles are allowed.

If other approved exhaust material is used, then customer must supply a 90 degree adaptor made of the same material.

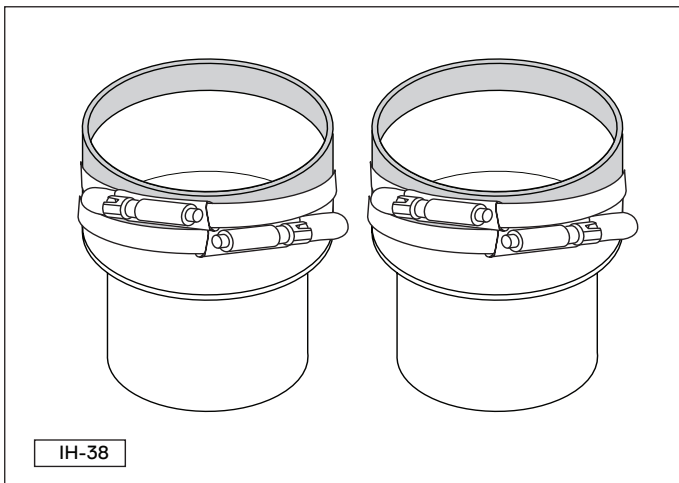

SAFETY INSTRUCTIONS

On multiple unit installations, the air intake inlet and exhaust gas outlet piping from each water heater must be connected into the properly-sized common piping. Use the table in “7.6 Intake Air Inlet and Exhaust Gas Outlet Pipe Diameter and Length” on page 28 to determine the diameter of the common connecting piping between each individual water heater.

4. Determine the length and corresponding diameter for the air inlet pipe and route the pipe to the desired termination location.
 - a. For termination of the pipe to the outside, continue installing the required pipe to a suitable outside location. Glue all connections, making sure the joints are sealed airtight.

- b. Install suitable pipe support hangers every 4 to 5 feet, or as local building codes require.

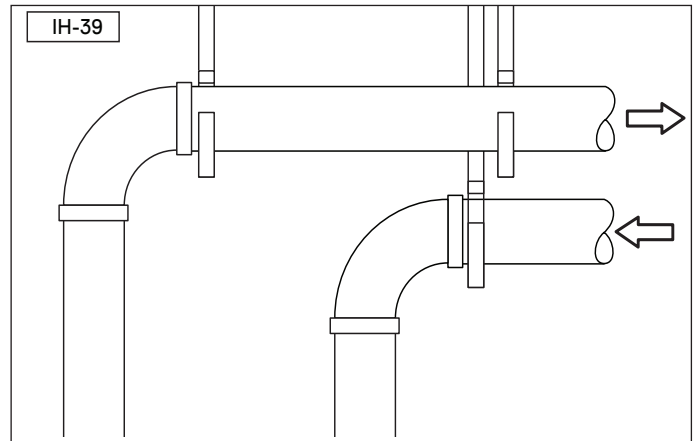

- c. To configure the unit for power vent, insert a 3' section of 6" pipe.
5. Determine the length and corresponding diameter for the exhaust gas outlet pipe and route it to a suitable outside location.
 - a. Glue all connections, making sure the joints are sealed airtight.
 - b. Install all horizontal exhaust gas outlet piping with a minimum 2 degree (1/4" per foot) slope back toward the water heater. This allows any condensate that accumulates in the exhaust gas outlet pipe to properly drain back into the unit.
 - c. Install suitable pipe support hangers every 4 to 5 feet, or as local building codes require.

SAFETY INSTRUCTIONS

Do not connect any other appliance vents to the water heater inlet or outlet pipes.

6. If multiple units are installed, make sure the diameter of the connecting exhaust gas outlet pipe is properly sized for the number of units being installed.

7.3 Two Pipe Vent System (Direct Vent)

7.3.1 Single Unit Configurations

The water heater can be directly vented without any modification using a 6 inch diameter pipe.

The following diagrams represent some typical direct venting configurations and are included to assist in designing the vent system. Possible configurations are not limited to the following diagrams.

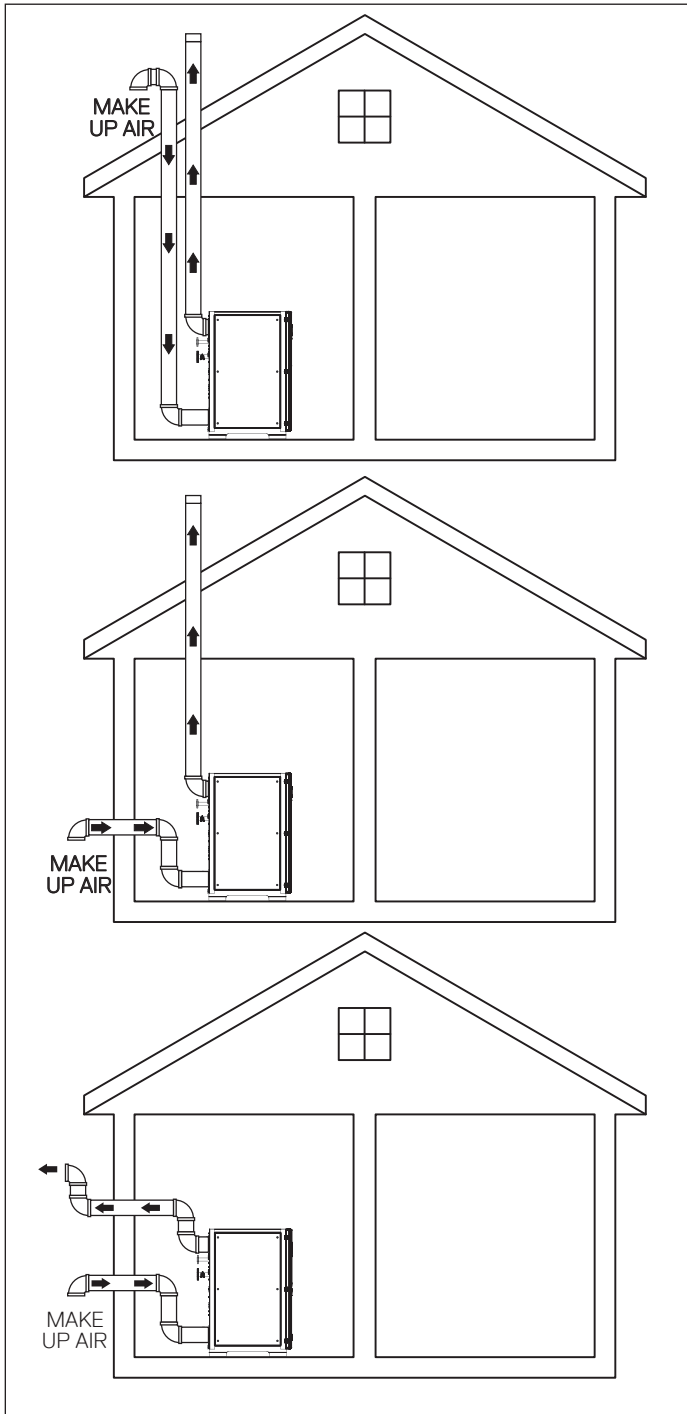

7.3.2 Multiple Units Configurations

When more than one unit is installed, refer to "7.6 Intake Air Inlet and Exhaust Gas Outlet Pipe Diameter and Length" on page 28.

Connecting multiple units together requires proper sizing of the air intake inlet and exhaust gas outlet pipes. Up to four water heaters can be connected (cascaded) together. Units common vented must be cascaded together, refer to "13. Connecting Multiple Units"

The following diagrams represent some typical direct venting configurations and are included to assist in designing the vent system. Possible configurations are not limited to the following diagrams.

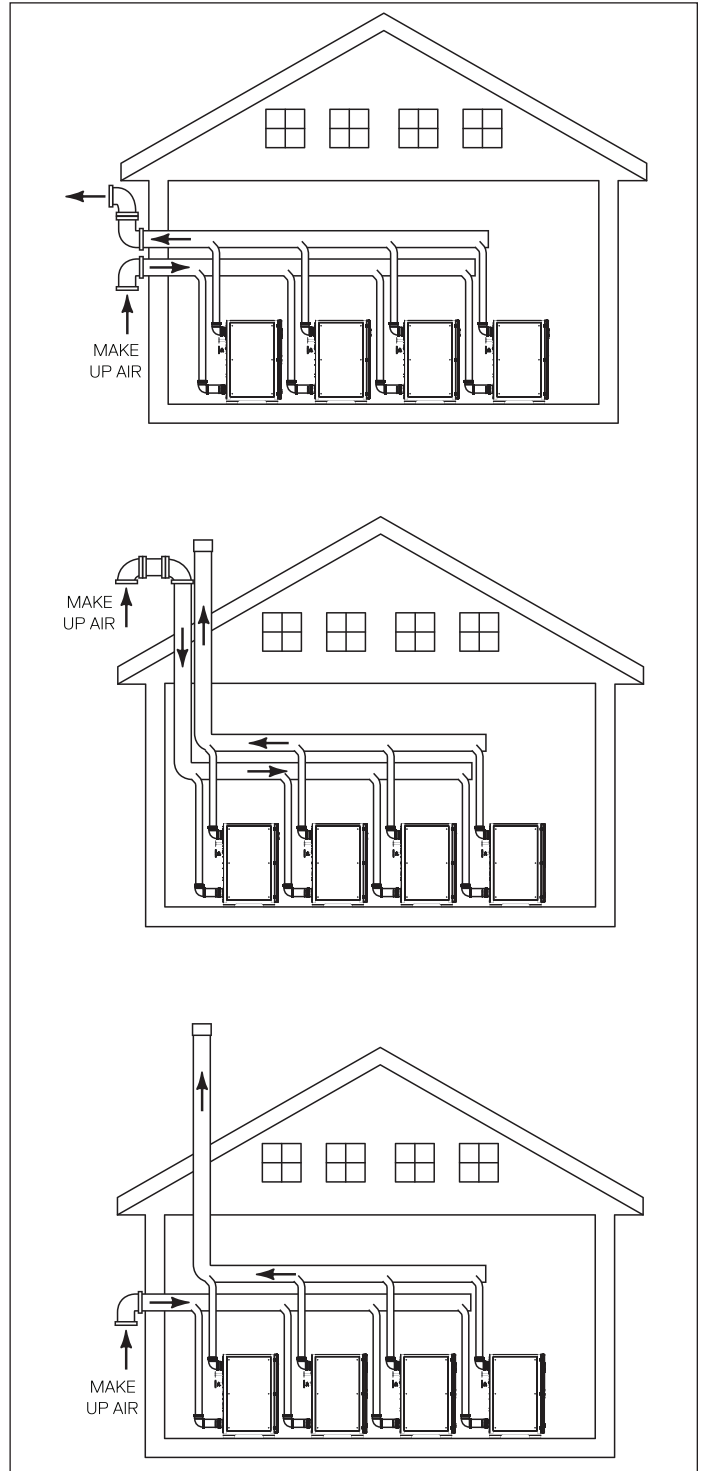

7.3.3 Side Wall Air Intake Inlet and Exhaust Gas Outlet Pipe Termination

1. Terminate the air intake inlet pipe with a 90° elbow (angled down). Use a flange and PVC screen (not supplied).
2. Terminate the exhaust gas outlet pipe on the exterior wall at least 12" above ground and at least 18" away from the air intake inlet pipe, or as required by local building codes. In areas of high snow fall, protect the vent terminations from blockage. Use a flange and PVC guard.

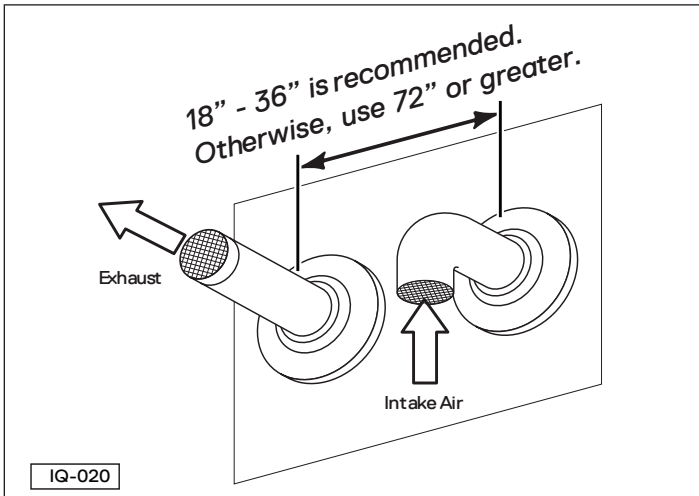

Single unit.

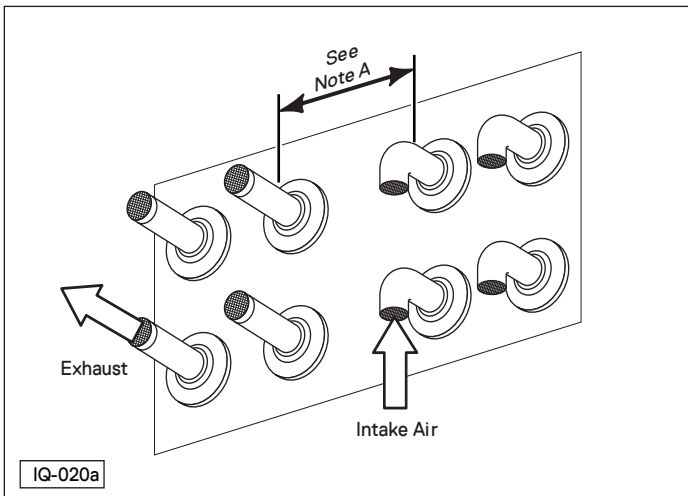

Multiple units.

Separation distance	Allowed
0 - 17.9"	Not allowed
18" - 36"	Allowed
36.1" - 71.9"	Not allowed
72" or greater	Allowed

3. To avoid moisture and frost build-up to openings on adjacent homes, use 45° elbows, 90° elbows, or tees for the vent termination to direct the exhaust gas fumes away from the building

7.3.4 Roof Air Intake Inlet and Exhaust Gas Outlet Pipe Termination

Venting the unit through the roof is also an option. With this installation method, the terminations must extend at least 12" over maximum potential snow levels, or as required by local building codes. In areas of high snow fall, protect the vent terminations from blockage.

Terminate the air intake inlet pipe with a 90° elbow (angled down). A suitable roof flashing and vent cap (not supplied) should be installed.

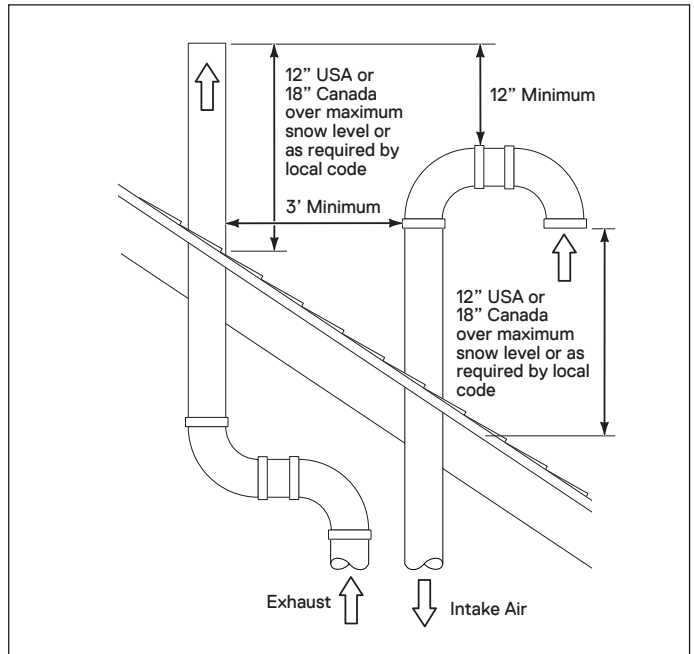

Single unit.

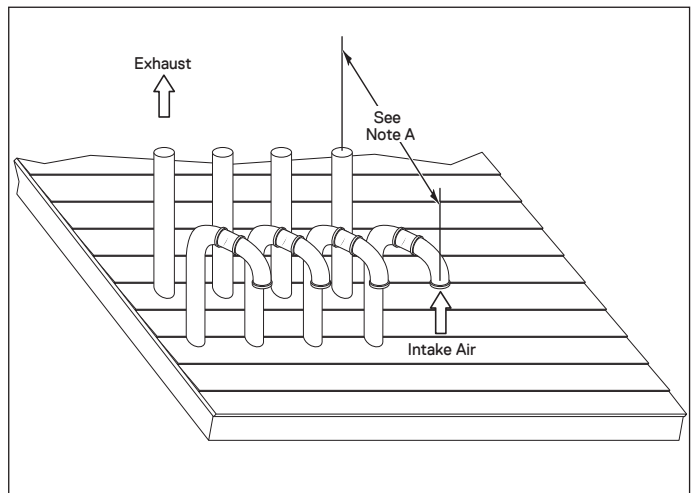

Multiple units.

Note A: The distance between any exhaust gas outlet and air intake inlet pipe should be between 18 and 36 inches apart. If this minimum specification cannot be met, the air intake inlet and exhaust gas outlet pipes should be 72 inches apart or more.

7.4 Single Pipe Venting System (Power Vent)

7.4.1 Single Unit

The following illustrations represent some typical power venting configurations and are included to assist in designing the vent system. Possible configurations are not limited to these designs.

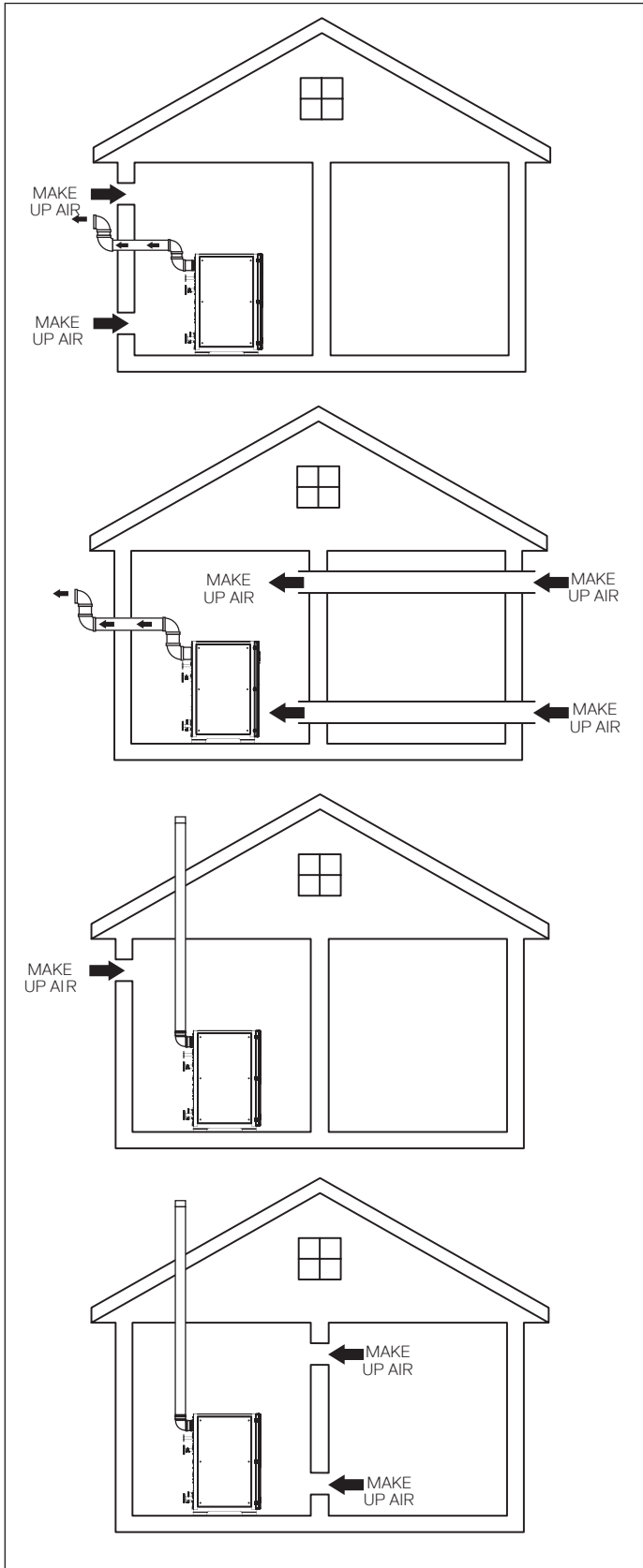

7.4.2 Multiple Units

When installing multiple units, refer to "7.6 Intake Air Inlet and Exhaust Gas Outlet Pipe Diameter and Length" on page 28.

Connecting multiple units together requires proper sizing of the air intake inlet and exhaust gas outlet pipes. Up to four water heaters can be connected (cascaded) together. Units common vented must be cascaded together, refer to "13. Connecting Multiple Units"

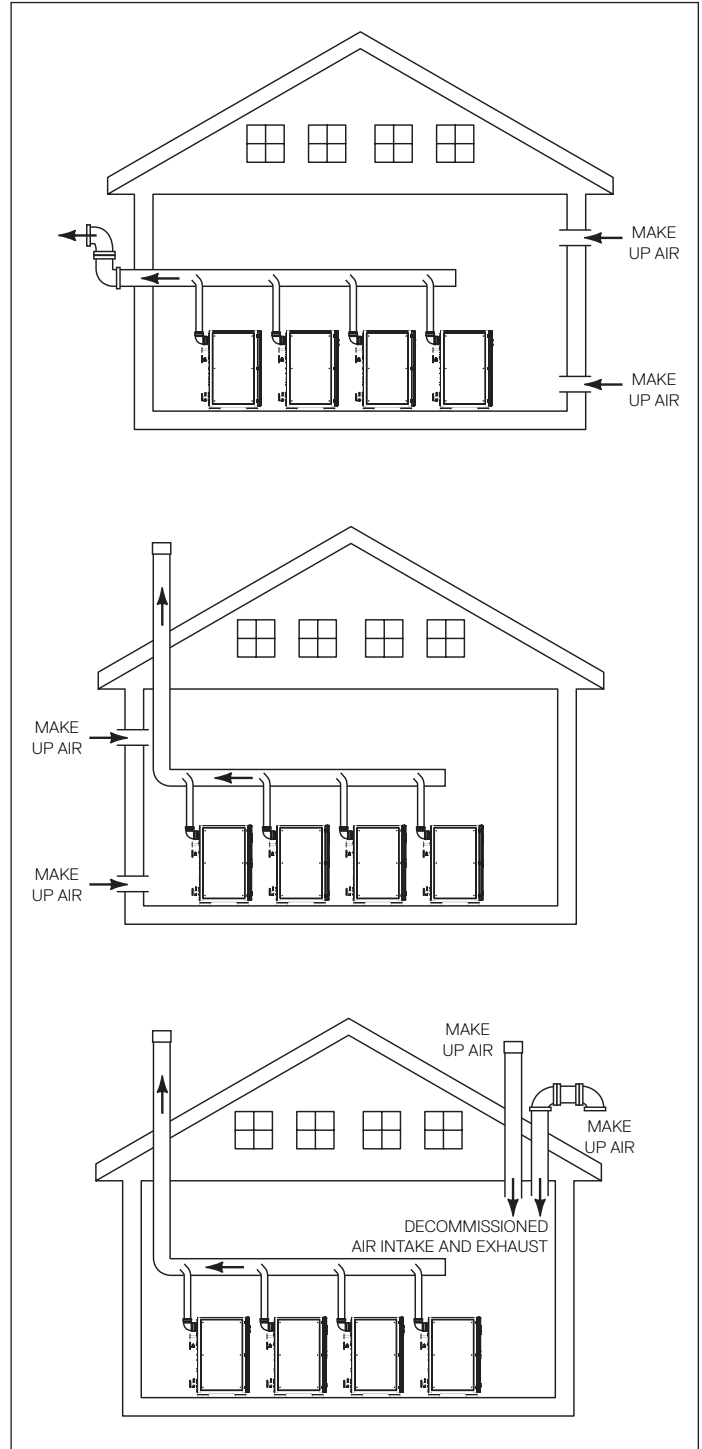

7.5 Combustion Air Requirements

When using the single exhaust gas outlet pipe or power vent method, the following table outlines the required opening sizes for the combustion and ventilation air coming into the room and the required CFM requirements per water heater:

SAFETY INSTRUCTIONS

Do not operate the unit in an area that will draw in outside air contaminated with high levels of dust, sawdust, aerosols such as paint, or other airborne contaminants.

If necessary, purchase and install appropriate air screens and follow a regular cleaning program to ensure an adequate supply of clean, outside combustion air.

Required Combustion & Ventilation Air Opening Sizes (sq. in.) Per Heater Per Boiler Room:							
Model	Input	Air Type	Required CFM	Air is drawn directly from outside into the mechanical room			Air is drawn from another interior space inside the building
				through two openings*, direct or vertical	through one opening**	through two horizontal ducts	
iQ751, Gen II	751,000	Combustion Air	135	188	250	375	751
		Ventilation Air	135	188		375	751
iQ1001, Gen II	1,001,000	Combustion Air	180	250	333	500	1001
		Ventilation Air	180	250		500	1001
iQ1501, Gen II	1,501,000	Combustion Air	270	375	500	750	1501
		Ventilation Air	270	375		750	1501

*Where two openings are used, one must be within 12 inches of the floor and the other opening must be within 12 inches of the ceiling of the mechanical room.
 **Where one opening is required, it must be located within 12 inches of the ceiling.

7.6 Intake Air Inlet and Exhaust Gas Outlet Pipe Diameter and Length

The iQ751, iQ1001, and iQ1501 come factory installed with 6 inch polypropylene (PP) venting. The following chart outlines the maximum length of venting allowable for each model.

A vent system's length is calculated by adding the length of all straight runs used (both horizontal and vertical) and then adding the equivalent lengths of each turn (90° or 45° elbow) used in the system.

Please follow the minimum vertical pipe as mentioned in section 7.11.

SAFETY INSTRUCTIONS

A vent system's length must not exceed the maximum length outlined in the chart below.

Maximum Pipe Length in Feet																
Number of Units	Venting Type	Diameter, Model, and Length in Feet														
		6" Diameter			8" Diameter			10" Diameter			12" Diameter			14" Diameter		
		iQ751	iQ1001	iQ1501	iQ751	iQ1001	iQ1501	iQ751	iQ1001	iQ1501	iQ751	iQ1001	iQ1501	iQ751	iQ1001	iQ1501
1	1 pipe	220	130	65	500	500	270	500	500	500	500	500	500	500	500	500
	2 pipe	110	65	35	250	250	135	250	250	250	250	250	250	250	250	250
2	1 pipe	60	36		252	150	70	500	440	220	500	500	500	500	500	500
	2 pipe	30	18		127	75	35	250	220	110	250	250	250	250	250	250
3	1 pipe				120	70		360	212	110	500	500	250	500	500	500
	2 pipe				60	35		180	110	55	250	250	125	250	250	250
4	1 pipe				70	42		212	124	60	500	300	150	500	500	320
	2 pipe				35	21		106	62	35	250	150	75	250	250	160

1 pipe - Only the exhaust-out pipe is connected, and the combustion air intake is from within the room. For example, for one iQ751 with a 6" diameter, the maximum exhaust pipe length for one pipe is 220 feet.

2 pipes - Both the Combustion air intake and the exhaust pipe are connected. In this case, the table specifies the maximum length per pipe. For example, one iQ751 with a 6" diameter, 110 feet maximum, is allowed for the air intake and exhaust out pipe. The 110 feet maximum is per pipe.

Note:

- 1.Reduce the maximum equivalent length above by 5 feet per 90° elbow used and by 2 feet per 45° elbow used. Do not exceed the above set limits.
- 2.If multiple units are common vented, then the units must be cascaded. Please refer to the combustion section for how to do combustion with common vented units

7.7 Venting Clearance Specifications

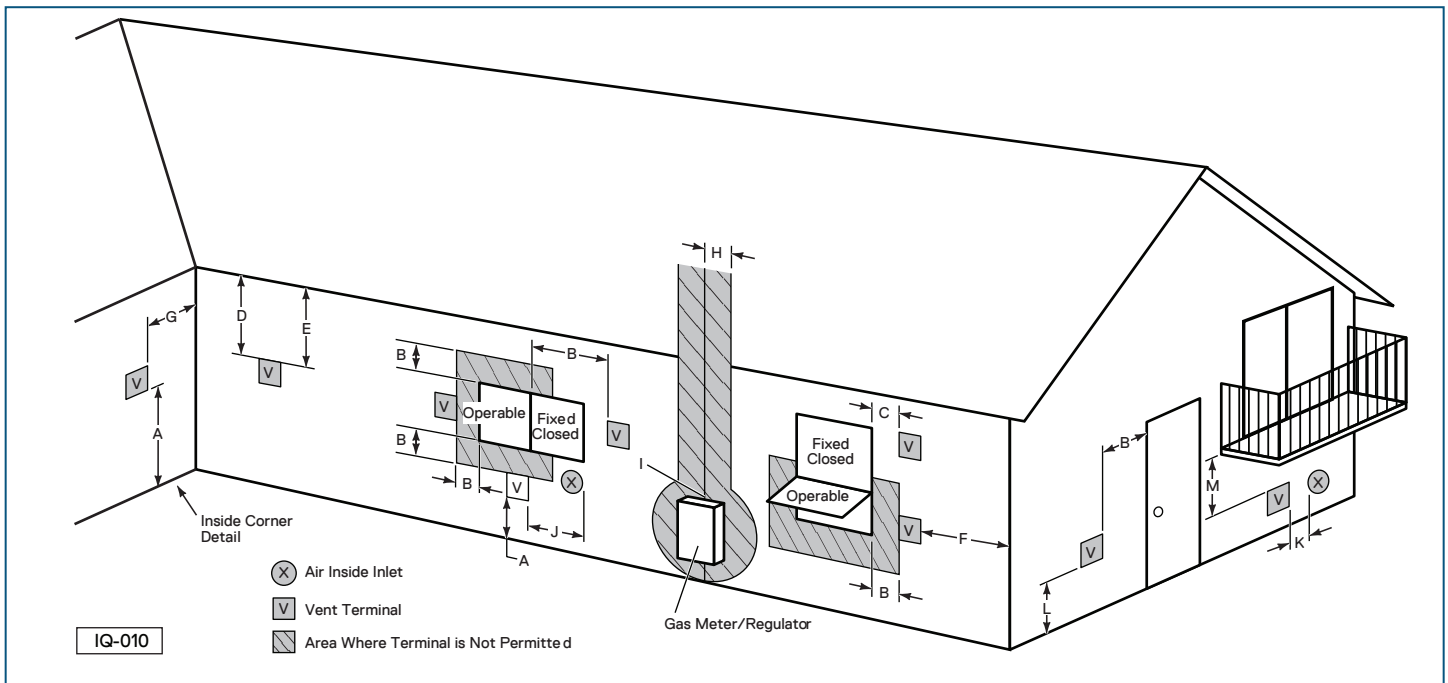

Venting Clearance Specifications			
Item	Description	Clearance Distance	
		USA ¹	Canada ²
A	Clearances above grade, veranda, porch, deck, or balcony	1 foot	1 foot
B	Clearances to window or door that may be opened	1 foot**	3 feet
C	Clearances to permanently closed window	*	*
D	Vertical clearance to a ventilated soffit, eaves, or overhang	*	*
E	Clearances to unventilated soffit, eaves, or overhang	*	*
F	Clearances to outside corner	*	*
G	Clearances to inside corner	*	*
H	Clearances to each side of centerline extended from meter/regulator	*	3 feet within a height 15 feet above meter/regulator assembly
I	Clearances to gas meter regulator vent outlet	*	3 feet
J	Clearances to non-mechanical air supply inlet or combustion air inlet to any other appliance	1 foot**	3 feet
K	Clearances to mechanical air supply inlet	3 feet above if within 10 feet horizontally	6 feet
L	Clearances to above paved sidewalk or paved driveway on public property	*	7 feet
M	Clearances under veranda, porch, deck, or balcony	*	1 foot

*Per local/gas supplier codes. Use clearances in accordance with local building codes and local gas supplier.
 ** For single vent pipe/direct 4 feet (1.2 m) below or to the side of opening and 1 foot above opening.
¹ In accordance with Z223.1
² In accordance with CSA B149.1

Note: The vent for this appliance shall not terminate:
 Over public walkways; or
 Near soffit vents or crawl space vents or other areas where condensate or vapor could create a nuisance or hazard or cause property damage; or
 Where condensate vapor could cause damage or could be detrimental to the operation of regulators, relief valves, or other equipment.

7.8 Exhaust Gas Outlet Pipe Materials

SAFETY INSTRUCTIONS

For Canadian installations, plastic exhaust gas outlet piping must comply with CAN/CGA B149.1 and be certified to the Standard For Type BH Gas Venting Systems, ULC-S636. Components of this listed system must not be interchanged with other vent systems or unlisted pipes or fittings. All plastic components and specified primers and glues must be from a single system manufacturer and must not be intermixed with another system manufacturer's products.

All units come factory installed with 6 inch polypropylene (PP) venting. A polypropylene to PVC adapter is included with each unit to enable the use of PVC exhaust gas outlet pipe. The maximum allowable venting distances are the same regardless of vent material selected.

The materials listed in the tables below outline the acceptable exhaust gas outlet pipe materials:

United States Exhaust Gas Outlet Pipe Standards	
Material	Description*
Exhaust Gas Outlet Pipe	PVC Schedule 40 (ASTM D1785)
	CPVC Schedule 80
	Approved Polypropylene
	AL29-4C Stainless Steel
Canadian Exhaust Gas Outlet Pipe Standards	
Material	Description (approved to ULC-S636)**
Exhaust Gas Outlet Pipe	Type BH Special Gas Vent Class IIA (PVC)
	Type BH Special Gas Vent Class IIB (CPVC)
	Type BH Special Gas Vent Class IIC (Polypropylene)
	Type BH Special Gas Vent Class I (AL29-4C Stainless Steel)
*Note: Use of cellular core PVC (ASTM F891), cellular core CPVC, or Radel (polyphenylsulfone) in nonmetallic venting systems is prohibited. Covering non-metallic vent pipe and fittings with thermal insulation is prohibited.	
**Note: The components (pipe, fittings, primers, and glues) must be from a single manufacturer; do not interchange. Follow the vent manufacturer's certified instructions.	

SAFETY INSTRUCTIONS

Do not use cellular foam core pipe to vent exhaust gases.

This water heater has a built-in exhaust gas outlet temperature control that limits the exhaust gas temperature to a maximum of 149°F (65°C) for PVC pipe. In commercial applications which require higher water temperatures, exhaust gas temperature can reach 190°F (88°C) and require materials such as polypropylene (PP), stainless steel (SS), or CPVC.

If the temperature approaches the upper limit, the burner will turn off automatically to protect the vent pipe. Once the exhaust gas temperature has dropped to a normal operating level, the unit will automatically restart.

If the inlet/return water temperature will exceed 150°F (66°C), do not use PVC pipe. Follow the display prompts to set the maximum water temperature for the exhaust gas outlet pipe material being used.

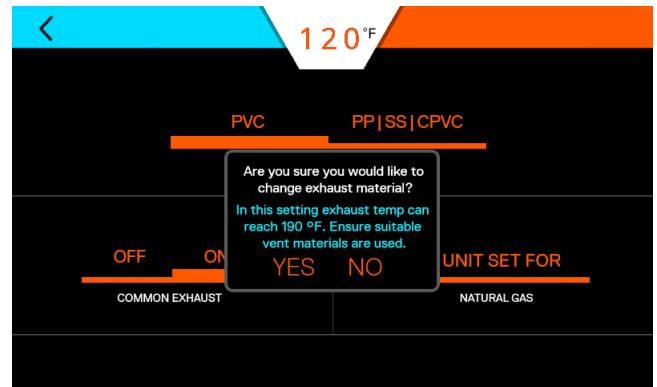
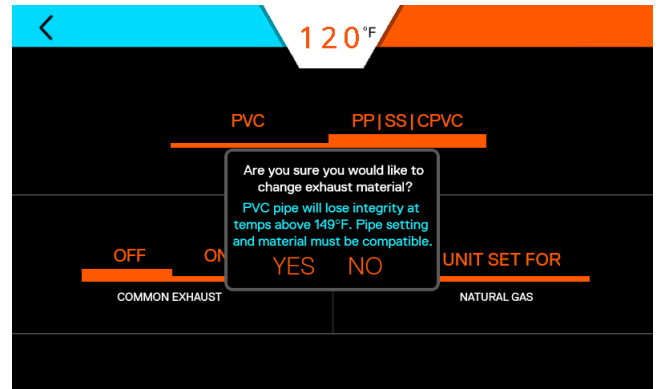

7.9 Air Intake Inlet Pipe Vent Materials

The air intake inlet pipe can be of any plastic or metal vent material available. ABS, PVC, polypropylene, galvanized steel, and/or flexible corrugated ducting are all examples. When using a corrugated material, ensure there is no inadvertent crimping or blockage to the air intake inlet pipe.

Refer to the table below for a list of approved materials.

United States Vent Pipe Standards	
Material	Description
Vent Pipe	PVC Schedule 40
	CPVC Schedule 80
	Approved Polypropylene

Canadian Vent Pipe Standards	
Material	Description
Vent Pipe	Type BH Special Gas Vent Class IIA (PVC)
	Type BH Special Gas Vent Class IIB (CPVC)
	Type BH Special Gas Vent Class IIC (Polypropylene)

Note: In addition to these charts, it is recommended to consult the most recent edition of ANSI Z223.1/NFPA 54 or CAN/CGA B149.1, as well as all applicable local codes and regulations when selecting vent pipe materials.

7.10 Recommended Exhaust Gas Outlet Pipe Transitions

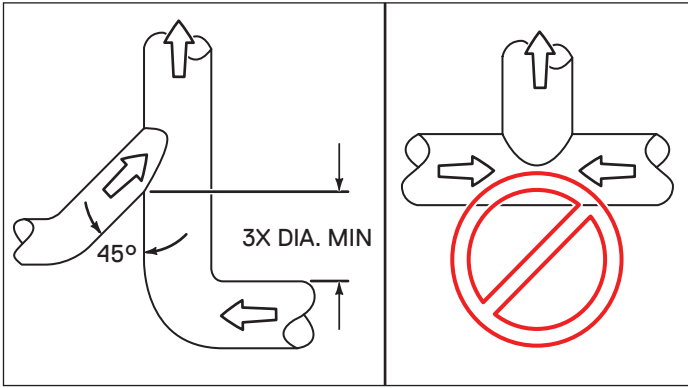

Do not direct exhaust gas from opposite directions. Use a 45 degree transition, as shown.

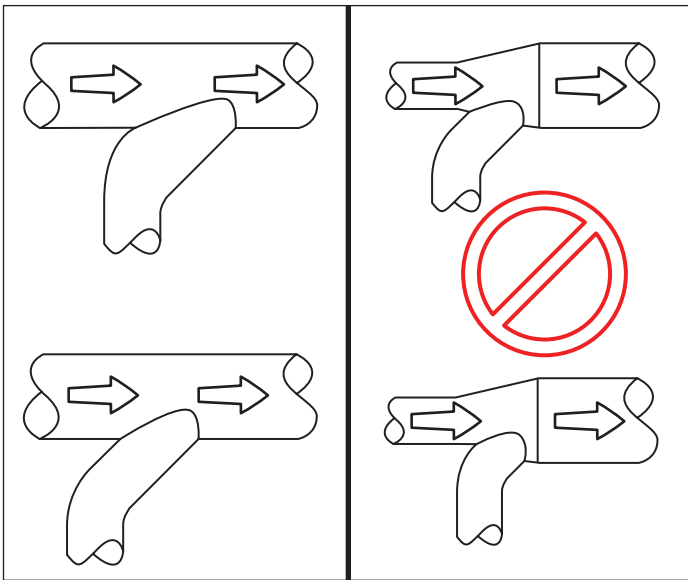

Do not transition into a reducer or use a t-fitting. Transitions should always be directed into a straight run of pipe.

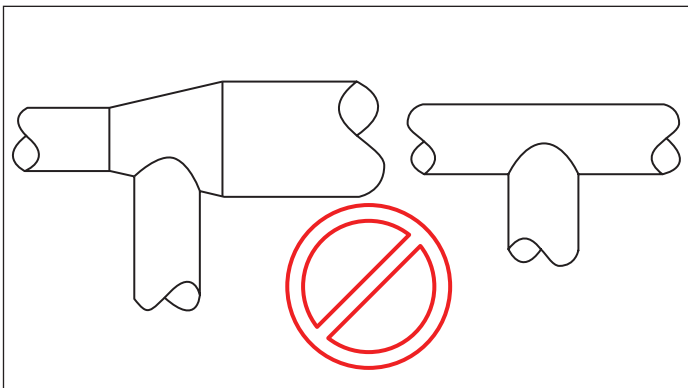

Do not use 90 degree transition into a reducer or a straight pipe.

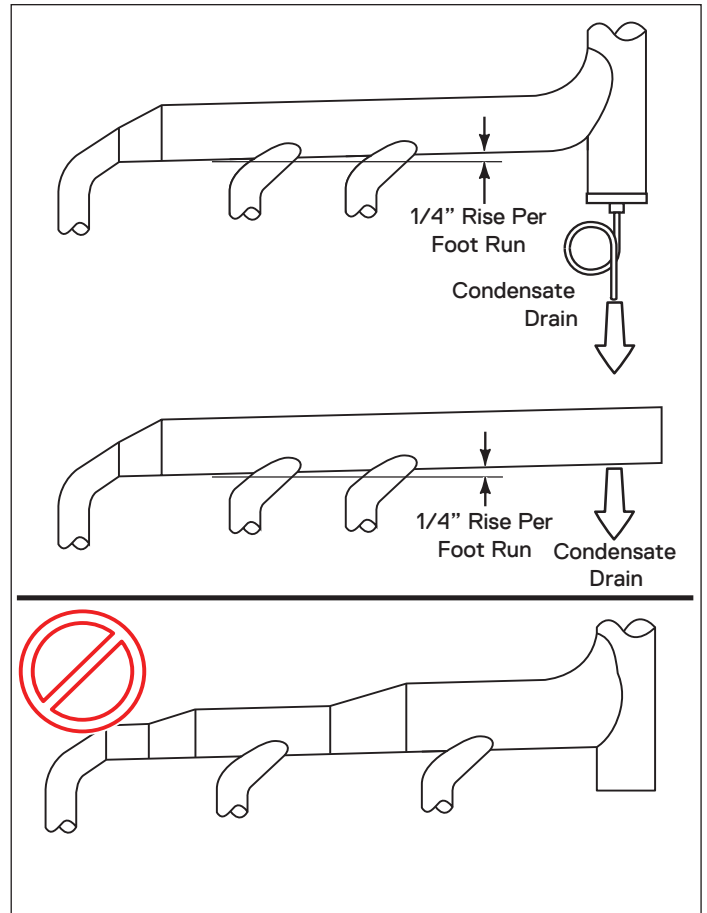

Do not use reducers in a straight run of pipe.

7.11 Adaptor Orientation

If PVC or CPVC pipe is being used, the included polypropylene to PVC adapters must be installed. If other approved exhaust material is used, then customer must supply a 90 degree adaptor made of the same material.

The adaptors must be installed as explained below. **Failure to do so would result in random blocked flue faults, degraded blower life and reduced system performance.**

7.11.1 Allowed

1. A minimum of 1.5 ft (18 inches) straight pipe is required before installing/introducing any turning adaptors (such as 30 deg, 45 deg, 60 deg or 90 deg).

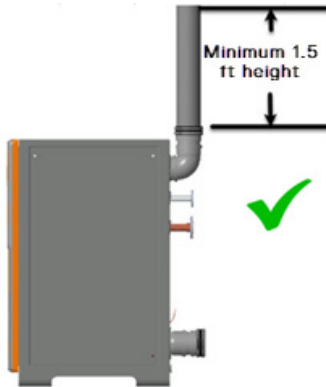

2. Rotating the elbow 45 degrees is acceptable. Do not exceed 45 degrees of rotation.

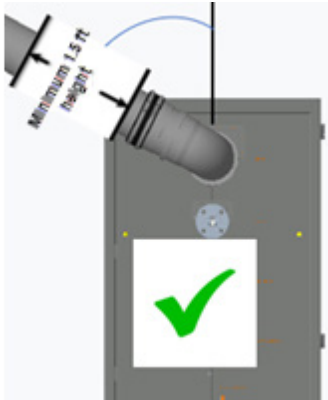

7.11.2 Not Allowed

1. Removing the 90 degree adaptor, or installing a straight pipe before the adaptor, is not allowed

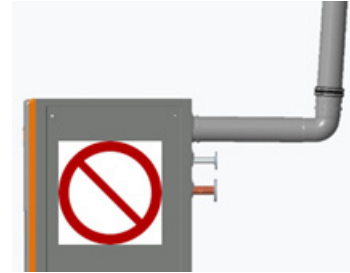

2. Rotating the adaptor 90 degrees so it is horizontal is NOT acceptable as this changes exhaust pressure drastically



3. Do NOT install any elbows directly to the factory installed elbow



8. Water Connections

Note: The supplied water hammer arrestor with the water heater must be installed as explained in this section. Otherwise warranty will not be honored.

8.1 Quick Reference Installation Instructions

1. Install the hot water piping.

NOTICE

When tightening any fittings to the connections on the water heater, care should be exercised not to overtighten these joints and damage the unit.

2. Install the cold water piping.
3. Make sure the pressure relief valve is installed. If necessary, install a customer supplied relief valve.
4. Install a condensate drain line.
5. After installation has been completed, test the water heater for proper flow and inspect for leaks.
6. Run the hot water for a few minutes and then clean the inlet water strainer located on the cold water inlet fitting. This strainer must be cleaned periodically to maintain proper water flow.

8.2 Hot Water Connection

Install and connect the hot water lines. Keep the hot water pipes as short as possible to deliver hot water to the fixtures quickly. If an optional hot water storage tank is required, connect the hot water lines to this tank also.

Since each installation is different, it is up to the installer to route the water lines using the most efficient routing. The drawings shown here are only suggestions indicating the items needed for the installation.

CAUTION

To prevent adverse health issues, only materials (pipes, fittings, valves, solder, etc.) that are approved for use in potable water systems should be used.

1. Connect a short section of 2" copper water line to the water heater's hot water connection.
 - a. The incoming flange, flange gasket, and stainless steel flange bolts must be supplied by the installer.
 - b. The flange connection uses a 6" OD, four-bolt brass flanged assembly.
 - c. The gasket material specs are an EPDM material with a minimum rating of 210°F continuous service or higher.
 - d. The flange bolts are a 3/8" diameter stainless steel. Also install stainless steel washers on both sides of the flange.

- e. Route the water lines from the water heater to the connection with the building's water pipes in the most efficient manner.

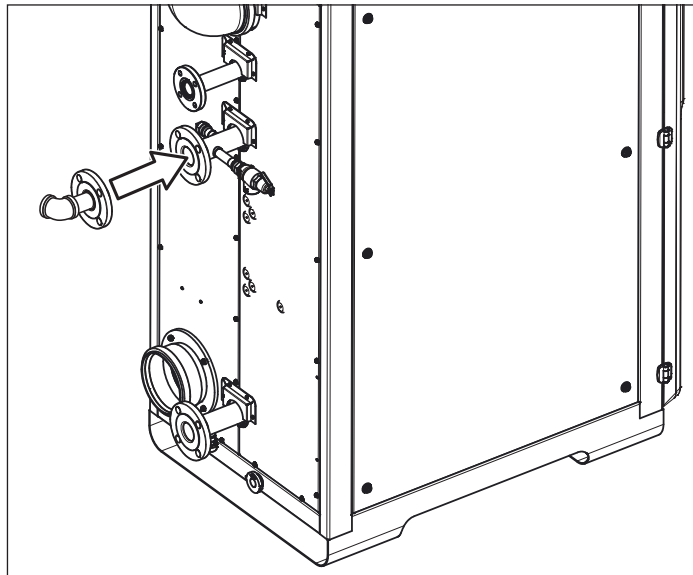

WARNING

To prevent serious personal injury, do not install any shut-off device between the water heater and the pressure relief valve. This valve is designed to release abnormally high pressure within the water heater in the event of a system problem.

2. If not factory installed, install the supplied 3/4" 150 psi maximum pressure relief valve, as required by your local code into the port on the outlet piping of the unit.

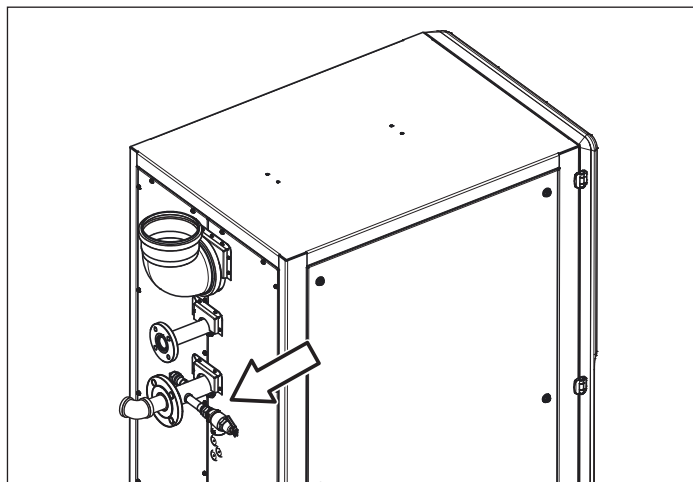

NOTICE

The pressure relief valve must be rated at 150 psi, the maximum btu/h input of the unit, and comply with all local building codes and standards. Do not install any restrictions or other valves in the pressure relief line.

3. Install and route a discharge pipe from pressure relief valve to within 6 inches of the floor and directed away from walkways or other appliances.
 - a. Route the relief valve to within 6 inches of the floor to prevent injury in the event of a discharge.
 - b. The diameter of the pipe from the relief valve must be equal to the outlet size of the relief valve.
 - c. Do not use reducers in the outlet piping.
 - d. Do not install any valves, restrictions, or other blockages in the outlet piping.
 - e. For multiple unit installations, the outlet piping must not be connected together. Each line must be separately routed to a suitable drain.

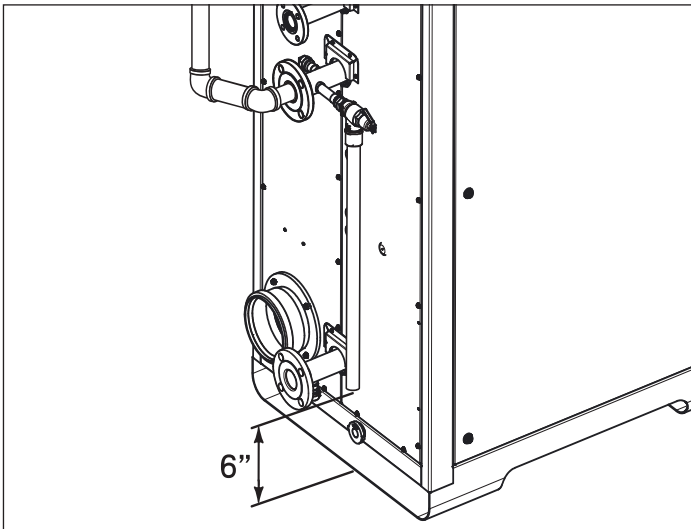

4. Following local building codes, install a manual shut-off valve.

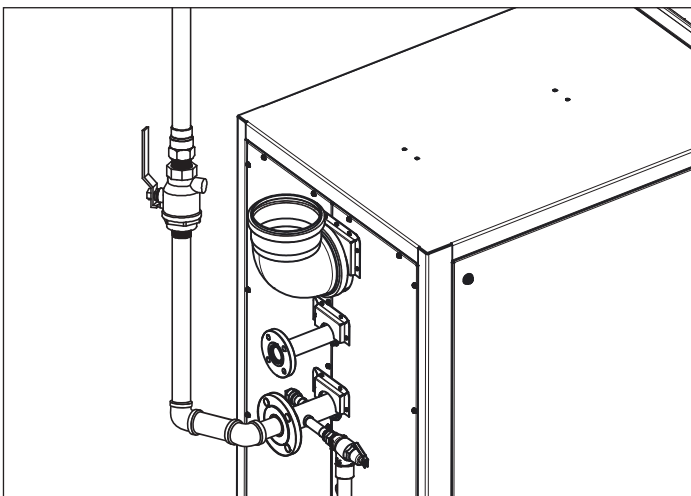

5. Install the water hammer arrestor as shown below. Failure to do so will void the warranty.

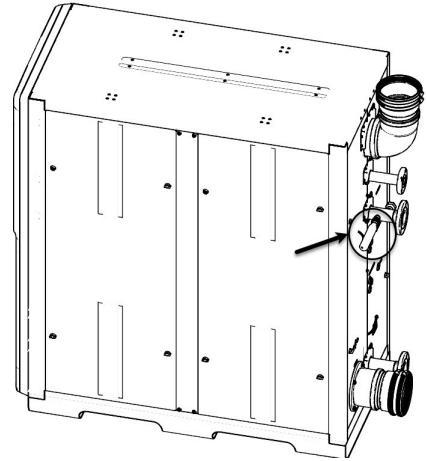
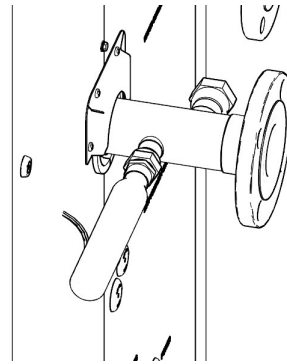

Connect the unit to the building's hot water lines. If multiple water heaters are being installed, the diameter of both the main cold water lines and the main hot water lines need to be sized appropriately.

6. To conserve energy, insulate all hot water piping.

SAFETY INSTRUCTIONS

Do not insulate the pressure relief valve.

7. With the unit OFF, open a nearby hot water faucet and allow the water to run through the unit until all the air is exhausted from the water lines and from the water heater.
8. Leak test the water piping. Repair any leaks immediately.

Note: For energy conservation, the hot water pipes should be insulated. Also insulate any recirculation water lines.

8.3 Cold Water Connection

Install and connect the cold water lines.

Note 1: If the incoming water is known to have a high mineral content or "hardness" (see warranty section), treatment is recommended upstream from the water heater.

Note 2: A water inlet strainer must be installed prior to use. This strainer must be inspected and cleaned after initial operation of 3 hours. Subsequently inspect the strainer at least every 3 months to establish a cleaning schedule.

When the water heater is installed in a closed loop recirculation system, and if the cold water supply line has a back flow preventer, then an expansion tank should be installed to allow for water expansion.

CAUTION

To prevent adverse health issues, only materials (pipes, fittings, valves, solder, etc.) that are approved for use in potable water systems should be used.

1. Connect a short section of 2" copper water line to the water heater's cold water connection.
 - a. The incoming flange, flange gasket, and stainless steel flange bolts must be supplied by the installer.
 - b. The flange connection uses a 6" OD, four-bolt brass flanged assembly.
 - c. The gasket material specs are an EPDM material with a minimum rating of 210°F continuous service or higher.
 - d. The flange bolts are a 3/8" diameter stainless steel. Also install stainless steel washers on both sides of the flange.
 - e. Route the water lines from the water source to the water heater connection in the most efficient manner.

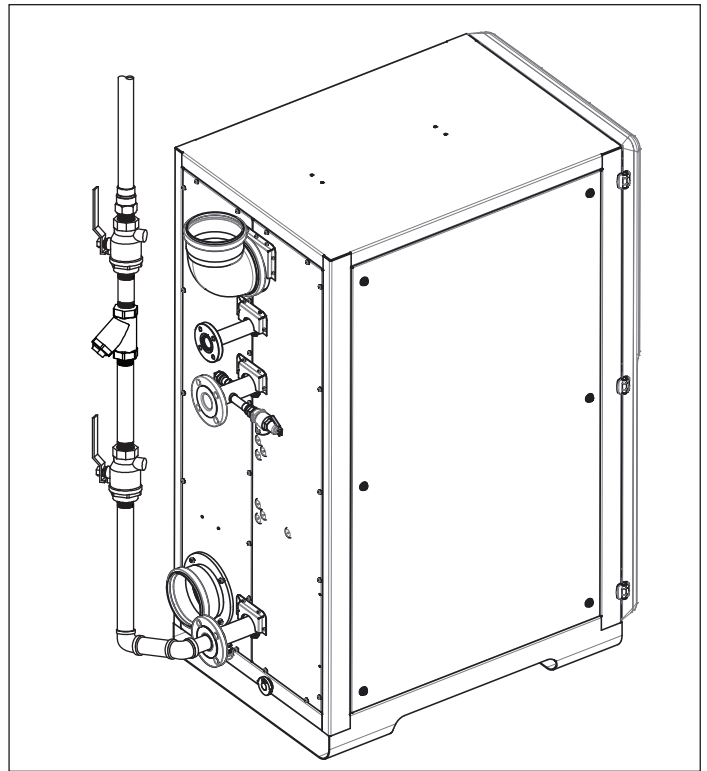

3. Connect the unit to the building's cold water lines. If multiple water heaters are being installed, the diameter of the main cold water line needs to be sized appropriately.

Note: Isolation valve kits can be used if incoming water treatment is anticipated (such as a water softener) due to hardness levels or heavy usage of the unit.

4. With the unit OFF, open a nearby cold water faucet and allow the water to run through the unit until all the air is exhausted from the water lines and from the water heater.
5. Leak test the water lines. Repair any leaks immediately.

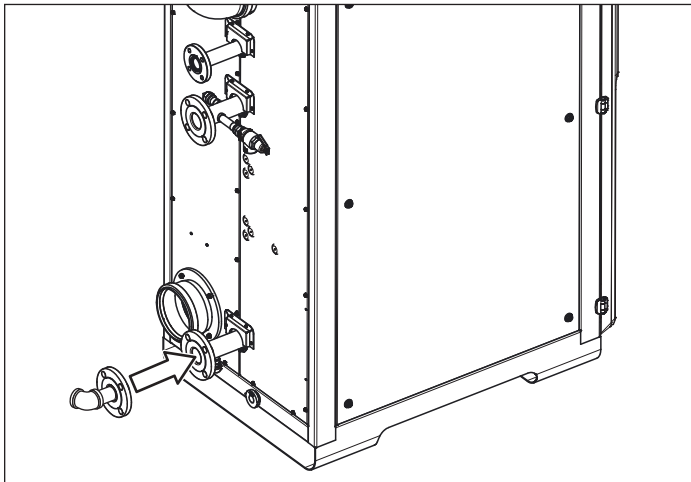

2. Following local building codes, install a manual shut-off valve.

8.4 Condensate Drain

Due to its efficient design, the water heater produces condensate (water) as a normal by-product of heating the water.

This condensate is acidic, with a pH level between 3 and 4. Local building codes may require an in-line neutralizer to be installed (not included) to treat this water.

The maximum condensate flow rate is 20 GPH.

Please make sure to select the condensate drain pipe withstands acidic water. Drain lines may be constructed of PVC, or steel piping. PVC and steel pipe must be Schedule 40 or heavier.

8.4.1 Without Neutrliazer installations

1. Install a 3/4" PVC to the condensate drain connection on the water heater.
2. Route the drain connection over or into the drain.
3. Long drain lines should contain a union to facilitate servicing the unit or cleaning the drain line.

8.4.2 With Neutrliazer installations

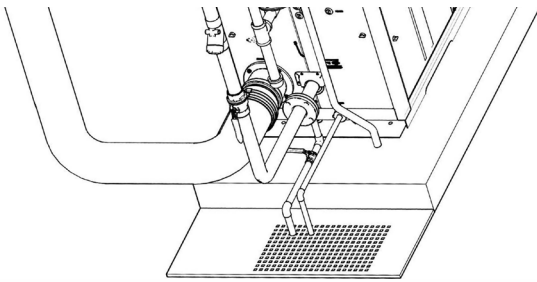

Since the condensate water is acidic, local building codes may require an in-line neutralizer to be installed (not included) to treat this water. This section explains the installation setup requirements.

1. There is no condensate pump inside the water heater to push the condensate water out. The condensate water flows out based on the slope and gravity. The neutralizer inlet connection should be below the water heater's condensate connection.
2. If the water heater is installed on top of a concrete pad, the neutralizer shall be installed below the concrete pad at the ground level.
3. Install Example#1

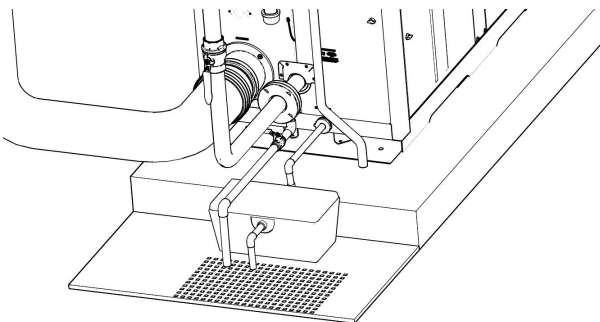

4. Install Example#2

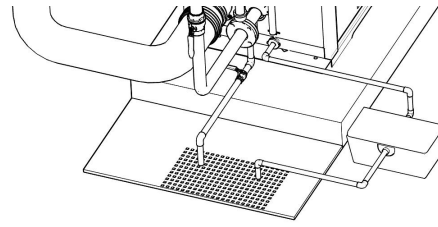

5. Install Example #3 (without concrete pad)

If unit installed without a concrete pad, the condensate lines must be routed to make sure it drains freely without any backflow.

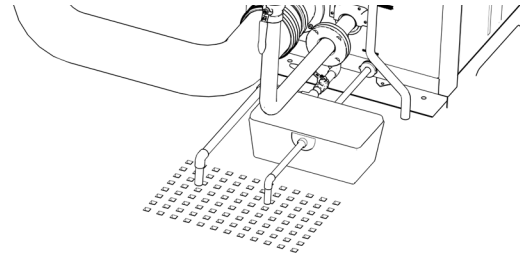

6. The following installation **is not allowed**, and would cause condensate blockage. The neutralizer should be installed below the concrete pad.

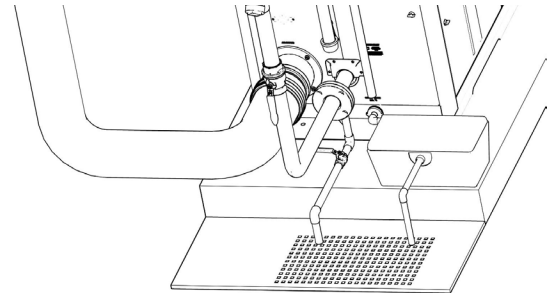

9. Electrical Power

9.1 Electrical Recommendations

⚠ WARNING

To avoid serious injury or even death, follow all applicable local, state, and national regulations, mandates, and building codes for guidelines to install the electrical power supply.

Electrical code requirements are different in the USA and Canada. Refer to and follow the local building codes, the latest edition of the National Electrical Code (NFPA 70) in the USA, or the CGA C22.1 Canadian Electrical Code - Part 1.

For a single iQ751 or iQ1001 water heater, the circuit breaker(s) should be at least 20 amps.

A minimum 30 Amp circuit breaker should be installed for the iQ1501. Please follow the local electrical code in determining the appropriate breaker size.

For multiple units, install an 80 amp for iQ751 or iQ1001 and a 120 Amp for iQ1501. Installing a separate circuit breaker for each unit is required to isolate units during service or repair.

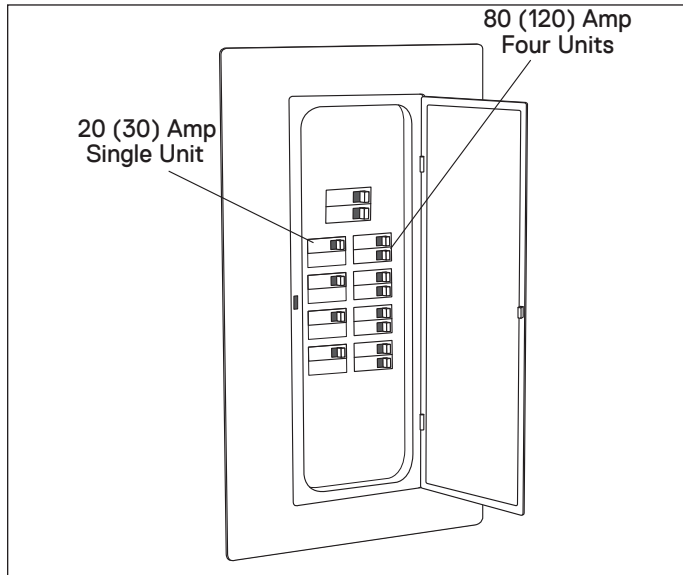

Note: For an electrical wiring schematic, refer to "15. Wiring Diagrams and Troubleshooting" on page 57 for additional information.

NOTICE

The electrical connections for the water heaters are polarity sensitive. Before connecting the water heater to the power source, test the polarity of the electrical circuit.

9.2 Connection Instructions

1. On single unit installations, make sure the electrical outlet being used is wired with appropriately-sized (or at least 10 gauge) wire and grounded with an appropriately-sized circuit breaker. Please note that the wire size varies based on the breaker size. The electrical power required for the water heater is 120V AC at 60 Hz.

2. Remove the two cover screws and open the cover.

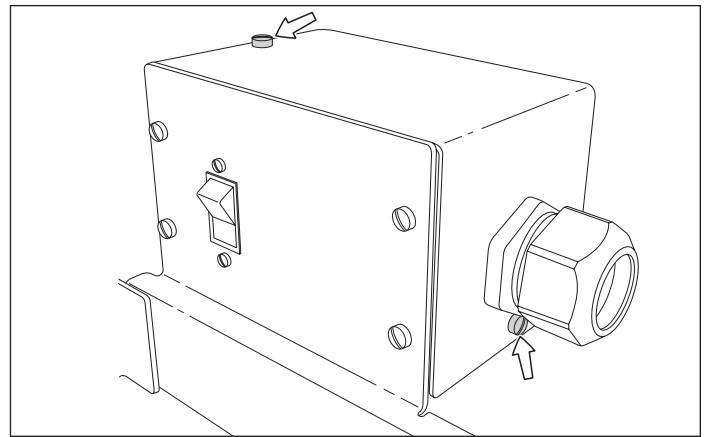

⚠ WARNING

To avoid serious injury or even death from electrical hazards, an additional ON/OFF electrical junction box should be installed near the water heater. This switch will allow power to be removed from the water heater prior to service or in the case of an emergency.

3. Route a customer-supplied appropriately-sized (or at least 10 gauge) wire with ground from an electrical junction box with an ON/OFF switch through the back panel of the water heater. Route the wire through the cabinet to the junction box.
4. On the opposite side of the block from the factory installed wiring, connect the white wire to the white terminal, the black wire to the black terminal, and the green ground wire to the green terminal.

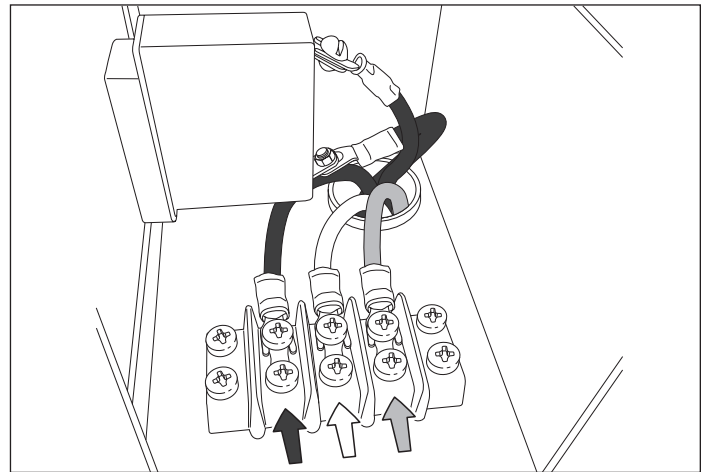

⚠ DANGER

Do not change internal power wiring connections of the terminals.

5. If multiple units are being installed, install each with a dedicated, appropriately sized circuit breaker. For installing multiple units, refer to "13. Connecting Multiple Units" on page 51 for additional information.

10. Adjusting CO2 Level

10.1 General Information

This procedure is required:

- 1) only during installation in a high-altitude location over 2,000 feet, or
- 2) when converting the unit from natural gas to propane.

This procedure should be performed only by a qualified technician.

⚠ DANGER

A concentration of carbon monoxide (CO) as small as 0.04% (400 parts per million) in the air can be fatal. When making High Fire and/or Low Fire adjustments, CO levels must be monitored using a flue gas analyzer and must not exceed 400 ppm of CO at any time during the operation.

Adjusting the “Low Fire screw” or the “High Fire screw” even in small increments can result in a significant increase in CO concentration. To avoid serious injury or death, DO NOT make any adjustments to the gas valve without monitoring the exhaust gases with a functional and calibrated flue gas analyzer.

CO ₂ and CO Standards		
Description	CO ₂ Range (%)	Max. CO Level (ppm)
Natural Gas		
High Fire	9.1% to 9.3%	< 200 ppm
Low Fire	9.1% to 9.3%	< 60 ppm
Propane		
High Fire	10.1% to 10.5%	< 200 ppm
Low Fire	10.1% to 10.5%	< 60 ppm

NOTICE

1. The values listed in the table are for nominal conditions. Variables such as gas pressure, heating value of the gas, humidity, and temperature of combustion air can impact CO and CO₂ values. Changes in these variables can result in different CO and CO₂ values on the same water heater.

2. A qualified service technician must use a calibrated flue gas analyzer to adjust the gas valve to achieve the desired CO₂ and CO values.

3. Before any adjustments are made, the service technician must confirm the static gas pressure meets these minimum requirements.

Natural Gas - 8" W.C.

Propane - 11" W.C.

4. If units are **cascaded and common vented**, then combustion must be performed only one unit at any given time. Please valve off the hot water outlet of other units and power off them before performing combustion.

10.2 Adjustment Procedure

1. The exhaust port is located at the back of the unit, at the 90 degree elbow.
2. Locate the gas valve on each heat engine. There are three heat engines in iQ751, four in iQ1001, and six in iQ1501.

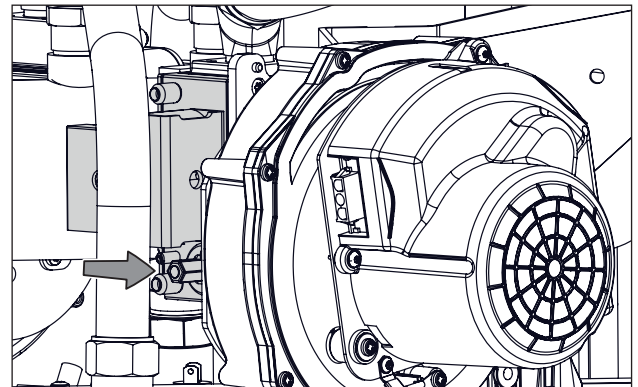
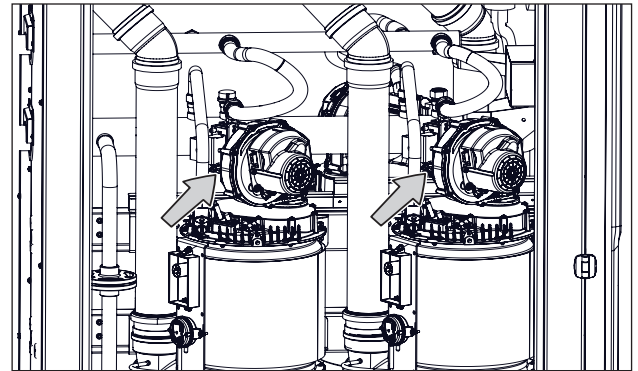

3. Remove the plug from the test port. Insert a calibrated flue gas analyzer into the test port.

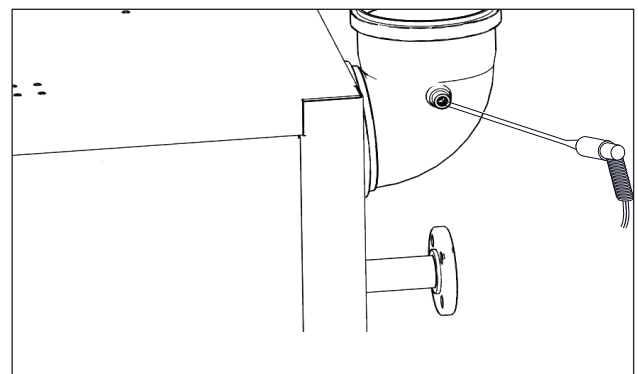
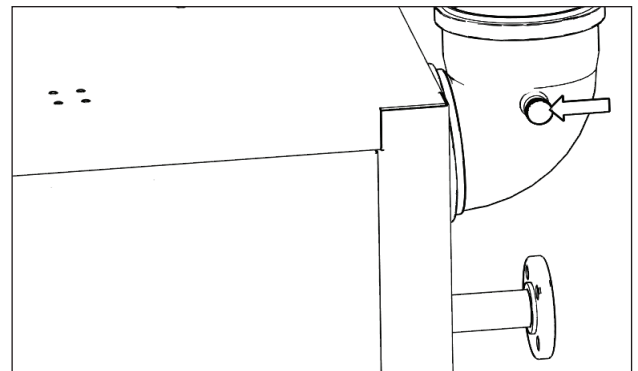

4. Follow the display screens.

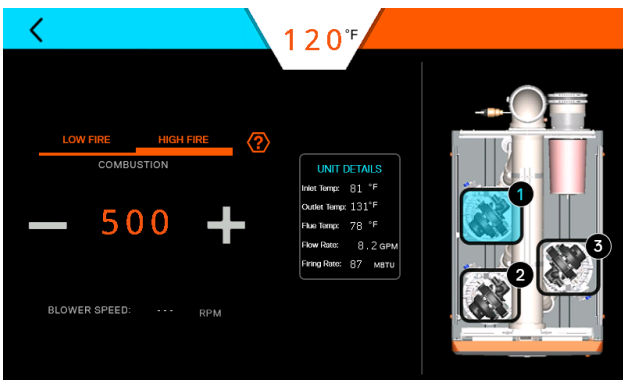
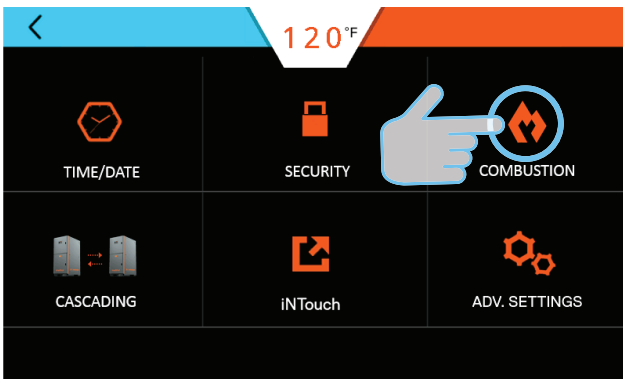
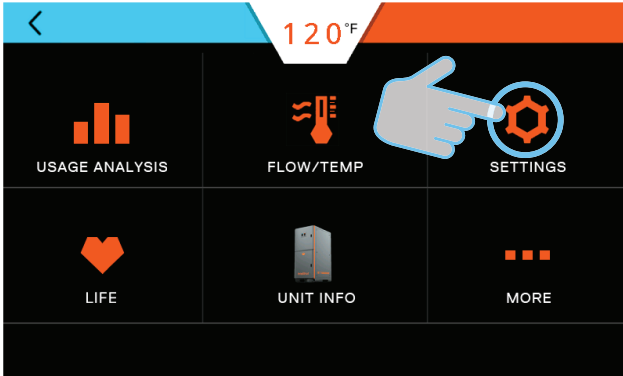
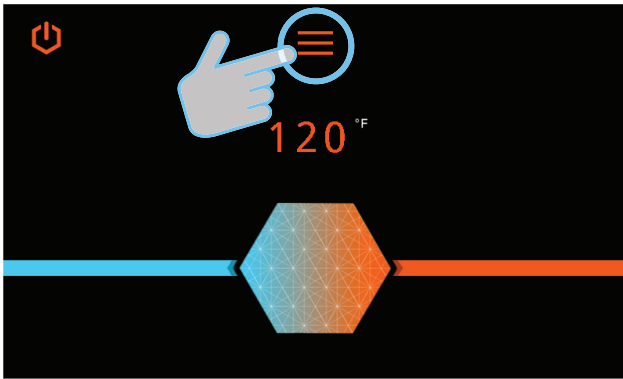

NOTICE

Do NOT change the blower speed settings. This adjustment MUST be performed by factory personnel ONLY. Changing this setting WILL VOID the warranty!

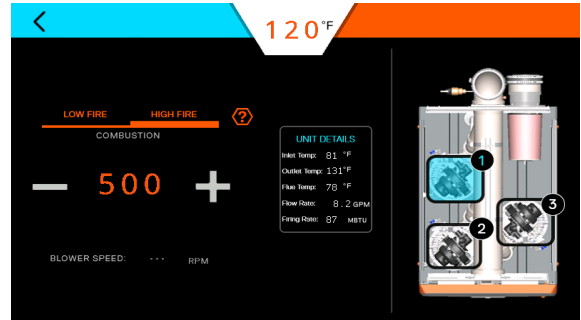

5. Create a hot water flow of at least 8.0 GPM as shown on the display screen.

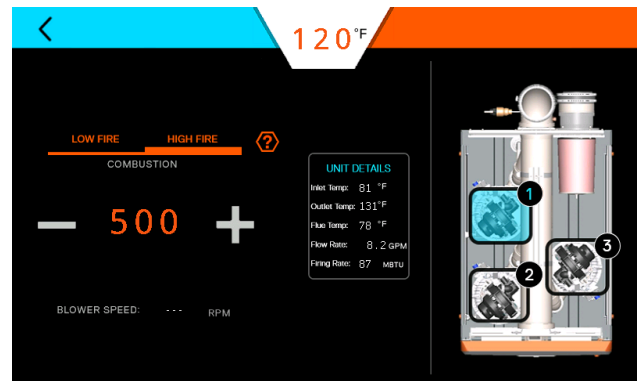

Note: If flow rate is inadequate, a pop-up message will notify to increase the flow.

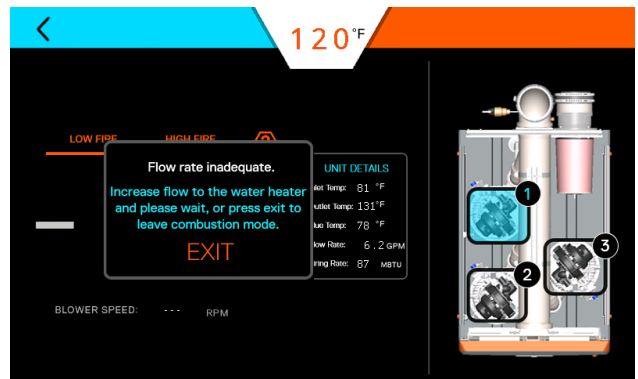

6. At a flow rate of 8.0 GPM, Heat Engine 1 (H1) will start.

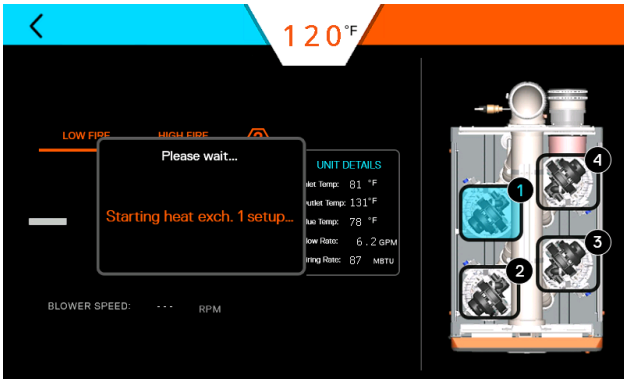

7. Allow three minutes of operation at High Fire.
8. Record "initial output" in Hire Fire Recorded Values table.
9. If the CO₂ values are within appropriate range, proceed to Step 10, otherwise continue.
 - a. Use a flat blade screwdriver to turn the High Fire screw clockwise to decrease and counterclockwise to increase the CO₂ value.
 - b. Adjust in ¼ turn increments.
 - c. Wait three minutes to stabilize flue gas readings and recheck values.
 - d. Adjust until values fall with specified range.

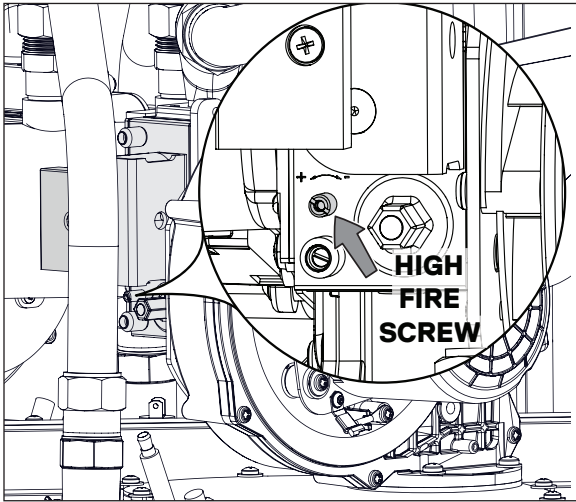

10. Once the desired values are achieved, record the new High Fire CO₂ "adjusted values" in the table.

High Fire Recorded Values		
Date ____ / ____ / ____		
Heat Engine (1)	Initial Output	Adjusted Value
CO ₂ Value %		
Max CO ppm		
Heat Engine (2)	Initial Output	Adjusted Value
CO ₂ Value %		
Max CO ppm		
Heat Engine (3)	Initial Output	Adjusted Value
CO ₂ Value %		
Max CO ppm		
Heat Engine (4)	Initial Output	Adjusted Value
CO ₂ Value %		
Max CO ppm		
Heat Engine (5)	Initial Output	Adjusted Value
CO ₂ Value %		
Max CO ppm		
Heat Engine (6)	Initial Output	Adjusted Value
CO ₂ Value %		
Max CO ppm		

11. From the display screen, press Heat Engine 2 (H2) and repeat the High Fire procedure for all heat engines.

CO ₂ and CO Standards		
Description	CO ₂ Range	Max. CO Level
Natural Gas High Fire	9.1% to 9.3%	< 200 ppm
Propane High Fire	10.1% to 10.5%	< 200 ppm

12. Press LOW FIRE on the display screen.

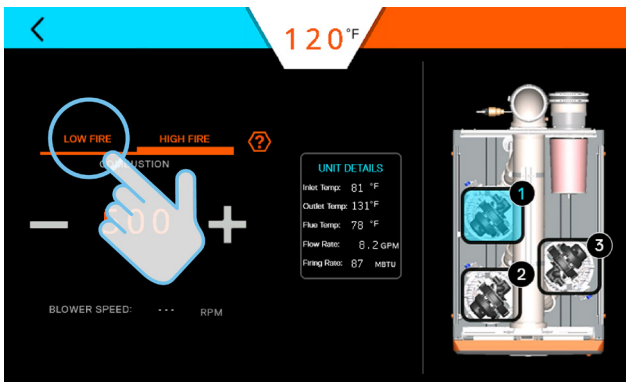

13. Record "initial output" in Low Fire Recorded Values table.

CO ₂ and CO Standards		
Description	CO ₂ Range	Max. CO Level
Natural Gas Low Fire	9.1% to 9.3%	< 60 ppm
Propane Low Fire	10.1% to 10.5%	< 60 ppm

Low Fire Recorded Values		
Date ____ / ____ / ____		
Heat Engine (1)	Initial Output	Adjusted Value
CO ₂ Value %		
Max CO ppm		
Heat Engine (2)	Initial Output	Adjusted Value
CO ₂ Value %		
Max CO ppm		
Heat Engine (3)	Initial Output	Adjusted Value
CO ₂ Value %		
Max CO ppm		
Heat Engine (4)	Initial Output	Adjusted Value
CO ₂ Value %		
Max CO ppm		
Heat Engine (5)	Initial Output	Adjusted Value
CO ₂ Value %		
Max CO ppm		
Heat Engine (6)	Initial Output	Adjusted Value
CO ₂ Value %		
Max CO ppm		

14. Adjust the Low Fire screw while the burner operates at low fire using a 2mm hex wrench. Turn clockwise to increase CO₂ and counterclockwise to decrease CO₂.

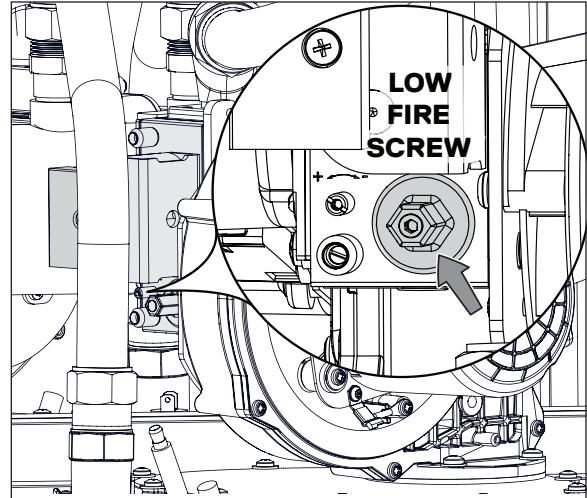

15. Once the desired values are achieved, record the new Low Fire CO₂ "adjusted values" in the table.

16. From the display screen, press Heat Engine 2 (H2) and repeat the Low Fire procedure for all heat engines.

17. When all heat engines have been properly adjusted, turn off water flow.

18. Remove the flue gas analyzer probe and plug the test port.

19. Press the back button to return to the settings screen.

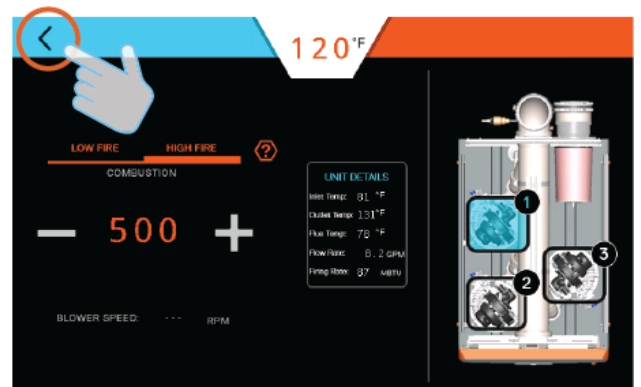

20. Check for gas leaks using a leak detector.

21. Install side panel covers. If converting to propane, proceed to section "11. Natural Gas to Propane Conversion" on page 42.

11. Natural Gas to Propane Conversion

SAFETY INSTRUCTIONS

A qualified service technician **MUST** make the required changes to convert the water heater from Natural Gas to Propane.

Propane conversion must be done within the 72 hours of the water heater being turned ON for heating the water.

⚠ DANGER

Improper propane conversion or not performing the conversion within the 72 hours could cause property damage, serious injury, or even death.

11.1 General Information

Note: This conversion process also requires the CO₂ levels to be adjusted. Refer to "10. Adjusting CO₂ Level" on page 38 for instructions.

Before converting the unit for propane, verify the current gas inlet pressure meets the recommended pressure and record it in the space below.

Propane Static Gas Pressure	
Parameters	Specifications
Minimum Static Gas Pressure	8" W.C. (non-corrugated, black iron)
Recommended Gas Pressure	11" W.C.
Maximum Static Gas Pressure	14" W.C.

Current Static Propane Gas Pressure _____ W.C.

Date _____

Note: This conversion process also requires the CO₂ levels to be adjusted. Refer to "10. Adjusting CO₂ Level" on page 38 for instructions.

11.2 Conversion Procedure

1. Follow these steps before repositioning the DIP switches.

a. Turn the water heater OFF using the display screen.

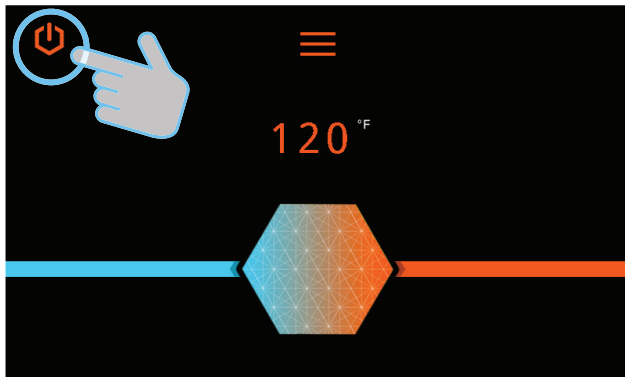

b. Place the circuit breaker for the water heater at the main electrical panel in the OFF position. Verify there is no power to the unit(s).

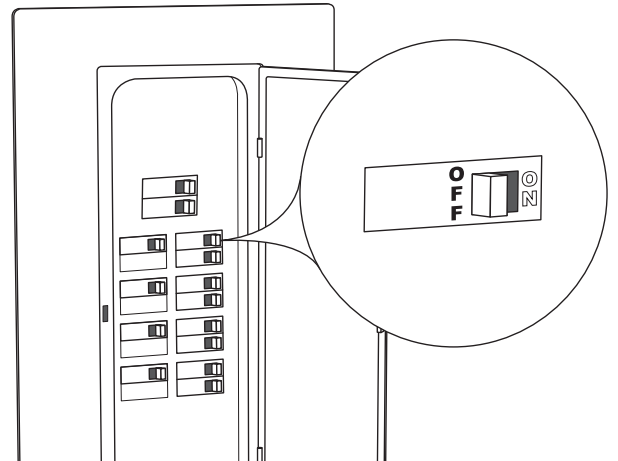

c. Open the front door and locate the main circuit board.

d. Locate DIP Switch 1 on each circuit board.

Note: Three control boards in iQ751,
Four control boards in iQ1001, and
Six control boards in iQ1501.

e. Move each DIP switch downward into the Propane position.

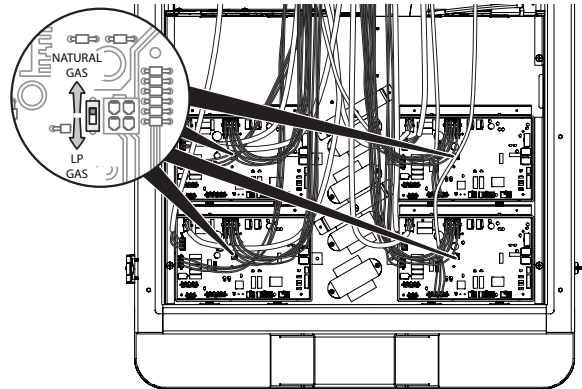

DIP Switch Settings (Réglages des commutateurs DIP)		
SW1	ON ↓ Propane	ON ↑ Natural Gas (Gaz naturel)

f. Reset the circuit breaker to the ON position. Turn the water heater ON using the display screen.

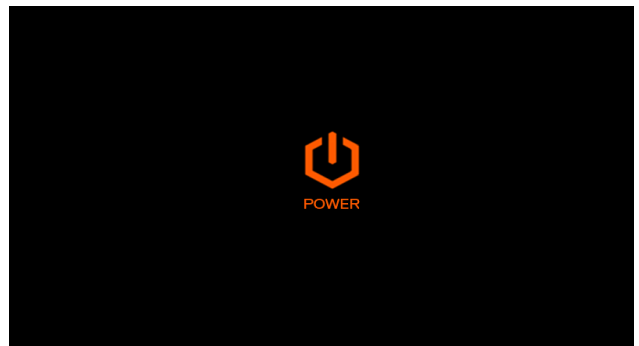

2. Follow the display screens to check if the unit is now set to propane.

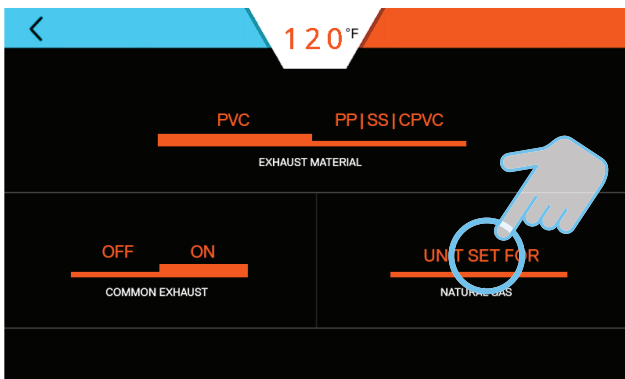
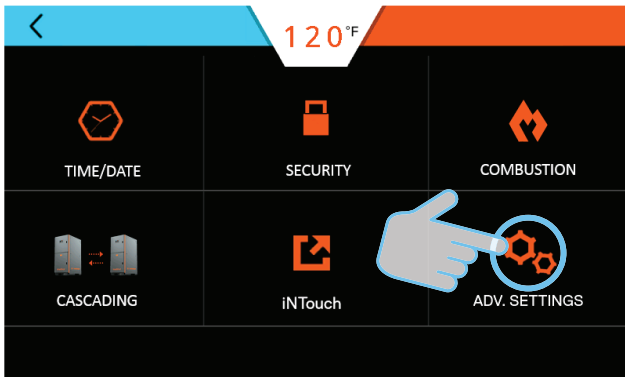
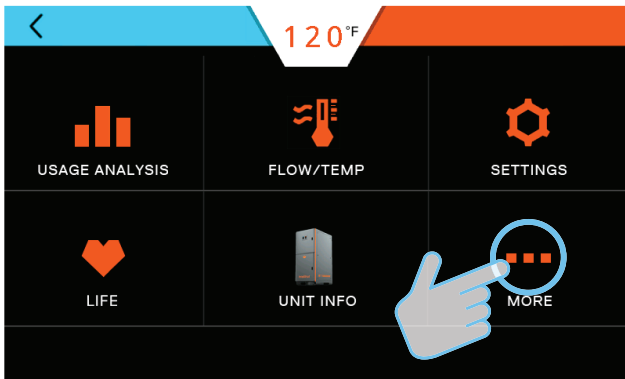
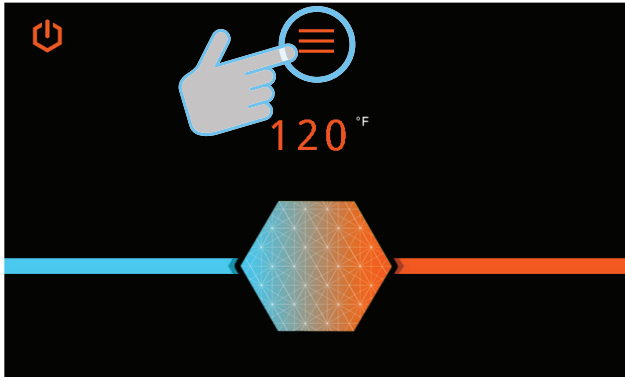

3. Refer to section "10. Adjusting CO₂ Level" on page 38 in this manual for instructions to adjust CO₂ levels.