

EF-3000 FULL FLOW DRINKING WATER SYSTEM



3,000
gallons

CAPACITY
11,356 Litres

The same commercial quality that makes Pentair® Everpure® the overwhelming choice for water filtration in restaurants is also available for your home—now without the need for extra faucets. The Pentair Everpure EF-3000 introduces great-tasting, crisp, cleaner filtered water at every regular tap in your home. The smaller canister size makes it an ideal system for any application where space is limited.

FEATURES • BENEFITS

- ◆ Easy installation
- ◆ No additional faucet required
- ◆ Built-in water shut-off allows for easier cartridge changes
- ◆ Great tasting water
- ◆ Reduces particles as small as 0.5 micron in size by mechanical means
- ◆ Retains vital minerals found naturally in water to ensure the delicious taste of your water
- ◆ Commercial grade filtration helps prevent lime and scale build-up in water-using appliances
- ◆ Commercial grade metal canister protects the filter system from splitting or bursting

SUBSTANCE REDUCTION

- ◆ Chlorine taste & odor
- ◆ Dirt and cloudiness
- ◆ Lead
- ◆ NSF/ANSI Standard 53 certified to reduce cysts such as *Cryptosporidium* and *Giardia* by mechanical means

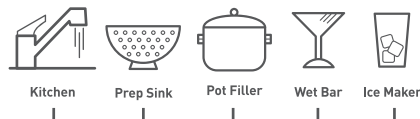

SPECIFICATIONS

- ◆ **Flow Rate**
controlled at 2.2 gpm (8.3 Lpm)
- ◆ **Temperature**
35-100° F (2-38° C)
cold water use only
- ◆ **Pressure**
10-125 psi (0.7-8.6 bar)
non-shock
- ◆ **Capacity**
3,000 gal. (11,356 L)
- ◆ **Required Space**
5W x 20H x 5D in
13W x 50.8H x 13D cm

ORDERING INFORMATION

MODEL	PART NO	DESCRIPTION
EF-3000	EV985700	Drinking water system
EF-3000	EV985750	Replacement Cartridge 1pk
EF-3000	EV985756	Replacement Cartridge 6pk



GENERAL INSTALLATION / OPERATION / MAINTENANCE REQUIREMENTS

This drinking water system must be maintained according to the manufacturer's instructions, including replacement of filter cartridges. The substances reduced or removed by this system are not necessarily in your water. Read the performance data sheet for more information. It is recommended that before purchasing a water treatment unit, you have your water tested to determine your actual treatment needs.

Space required: 13W x 50.8H x 13D cm (5W x 20H x 5D in) including 2-1/2 inches of clear space under unit for cartridge change

Do not use with water that is microbiologically unsafe or of unknown quality without adequate disinfection before or after the system. Systems certified for cyst reduction may be used on disinfected water that may contain filterable cysts.

Install vertically with cartridge hanging down

Flush new cartridge at full flow for three minutes to purge air

Replace cartridge when capacity is reached, or when flow becomes too slow, but at least annually

EASY INSTALLATION STEPS

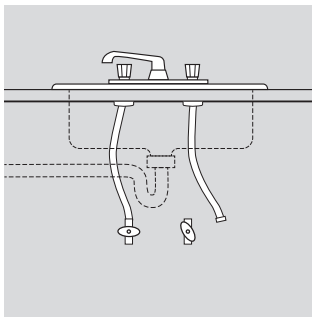

Shut cold water supply off and disconnect cold water hose.

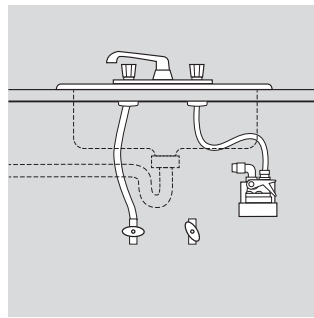

Connect cold water supply hose from faucet to outlet of filter head.

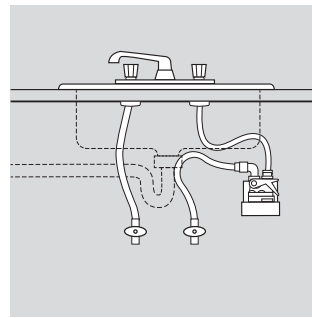

Mount filter head and connect water supply to inlet of filter head.

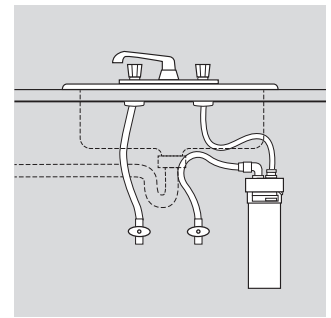

Install Quick Change cartridge and turn on water.

For detailed instructions, see the Owner's Guide.

HEALTH CLAIM PERFORMANCE CERTIFIED BY NSF*

This system has been tested according to NSF/ANSI 42 and 53 for the reduction of the substances listed below. The concentration of the indicated substances in water entering the system was reduced to a concentration less than or equal to the permissible limit for water leaving the system, as specified in NSF/ANSI 42 and 53.

SUBSTANCE	INFLUENT CHALLENGE CONCENTRATION	MAX. PERMISSIBLE PRODUCT WATER CONCENTRATION	REDUCTION REQUIREMENTS	MINIMUM REDUCTION	AVERAGE REDUCTION
Standard 42 – Aesthetic Effects					
Chlorine	2.0 mg ± 10%	-	≥ 50%	-	99%
Particulate, Class I					
Particles 0.5 - <1 µm	at least 10,000 particles/mL	-	≥ 85%		98.3%
Standard 53 – Health Effects					
Cyst	Minimum 50,000/L	-	99.95%	99.99%	99.99%
Lead 8.5	0.15 mg/L ± 10%	0.010 mg/L	-	93.2%	98.5%
Lead 6.5	0.15 mg/L ± 10%	0.010 mg/L	-	99.9%	99.9%

*Tested using flow rate = 2.2 gpm; pressure = 60 psig; pH = 7.5 ± 0.5; temp. = 20° C ± 2.5° C

Everpure®, Micro-Pure® and the silver canister color are registered trademarks of Pentair Filtration Solutions, LLC ©2023.

WARRANTY

Everpure Drinking Water Systems are warranted to be free of defects for a full twelve (12) months after purchase. A detailed warranty statement is provided with each system.



System Tested and Certified by NSF International against NSF/ANSI Standard 42 and 53 for the reduction of:

Standard No. 42 Aesthetic Effect:

- Chemical Reduction
 - Taste and Odor
 - Chlorine Taste & Odor
- Mechanical Filtration
 - Particulate Reduction: Class I

Standard No. 53 Health Effects:

- Chemical Reduction
 - Lead
- Mechanical Filtration
 - Cyst

EPA EST. NO. 002623-IL-002



13845 Bishops Dr. | Suite 200 | Brookfield, WI 53005 | United States
 P: 262.238.4400 | Customer Service: 800.279.9404 | tech-support@pentair.com | pentair.com

All indicated Pentair trademarks and logos are property of Pentair. Third party registered trademarks and logos are the property of their respective owners.

© 2023 Pentair. All rights reserved.

4003418 JL23