

# WaterGroup

The **Future**  
is **Here!**



## PRODUCT CATALOG

Water Conditioning Products  
For the Plumbing Professional



# TABLE OF CONTENTS

WaterGroup

4 -11

About WaterGroup



12 - 19

Water Conditioning Basics



20 - 45

Water Softeners & Filters



46 - 57

Aqua Flo and Aqua Flo Platinum  
Drinking Water Systems



58 - 74

PURA Ultraviolet Disinfection  
Systems



75 - 85

Aqua Flo Point-of-Use Filtration  
Products

86 - 104

Accessories

Chemical Feed Pumps  
Pro Chemicals  
Test Kits

Mazzei Injectors  
John Guest Fittings



105 -109

Water Conditioning Glossary

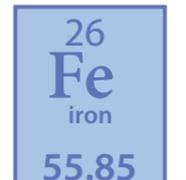

# Welcome To WaterGroup



I first started in the water conditioning industry in 1968 with a focus on growing and supporting the sale of water conditioning products through the Plumbing Trade.

Today our mission is the same – to provide plumbers and our wholesale partners with more value, features and support – constantly raising the bar and surpassing expectations!

When it comes to residential & commercial water treatment no one knows the industry better. Our Sales & Customer Service Team has more direct experience than any in the industry allowing them to offer you 'best in class' support.

We are committed to leading change bringing you modern designs, new features, great performance and unparalleled quality.

Let us show you the difference WaterGroup can make!

*"We believe that investment in products, a detailed focus on quality and recognizing the value of our people is the right foundation for the future"*

Don Fettes, President

## Don't Let Your Customers Spend Good Money For Bad Results...

### Money Leaking Down The Drain?

Chlorine is a strong oxidant that quickly destroys rubber seals & gaskets in appliances and plumbing fixtures causing leaks. Chloramines attack pipes causing pinhole leaks in plumbing.

A **WaterGroup 185 Whole-House Carbon Filter** protects plumbing and your customers from unwanted chlorine & chloramines.

#### Hard Water Damage?

Hard water scale and curd will damage pipes, fixtures, water using appliances, water heaters, clothing, dishes, hair & skin.

A **WG185UF High-Efficiency Water Softener** is an affordable solution!

### ...Fix The Water That Broke It!



# Industry Leaders in Customer Service

We are the fastest growing, most innovative manufacturer of high-quality water conditioning products in the world! **No one is doing what we are!**



## 1000+ Years of Industry Experience Value-Added Support From The Industry Experts

- ▶ Our **Regional Sales Managers** are in the field learning your business, understanding your needs and helping you grow! We have 35 RSM's with **700+** years of experience!
- ▶ Our **Customer Service Team** provides best-in-class technical support. Our 10 CSR's have over **200+** years of experience!
- ▶ Our **Dedicated Commercial Engineering Division** has the best Professional Engineers and Technologists with over **125+** years of combined experience



- ➔ Expert Technical Support
- ➔ Water Testing
- ➔ Product Selection & Sizing
- ➔ Order Placement
- ➔ Troubleshooting
- ➔ Specialized Commercial Engineering



Dave Pitman  
Commercial Engineering  
Manager



Dean Dalrymple  
Customer Service  
Manager

# Water Testing Services

Recommending a proper solution starts with a water analysis. Labs in Regina, Cambridge, Carmel, IN & Golden Valley can test your water samples for:

- 1) Hardness
- 2) Iron
- 3) Manganese
- 4) pH
- 5) Tannins
- 6) TDS



# Operations & Product Development



Toby Hughes P. Eng.  
Chief Operations Officer

Toby Hughes has managed some of the industries largest water conditioning manufacturing operations as well as toured the facilities of most industry manufacturers across the globe.

Toby brings almost 20 years of extensive industry experience to WaterGroup. Toby has managed product development as well as implemented Lean manufacturing, Continuous Improvement and Quality Assurance programs, MRP (Material Requirement Planning) systems to create an efficient, low cost and quality driven manufacturing environment.



*"The WaterGroup Product Development Center and manufacturing operations are beyond comparison in our industry. The investment in technology and commitment to leading manufacturing practices & innovation has resulted in higher quality and lower cost products with meaningful 'Installer / Service Driven' features. This all adds up to better value for our customers."*

*"My staff of 17 Professional Engineers, including 3 PhD's and 2 Masters, are some of the brightest minds in the industry. I am excited to lead WaterGroup's Global Engineering and Operations and raise the bar beyond industry standards and our customers expectations."*

*Toby Hughes*

Toby Hughes, P.Eng., Chief Operations Officer

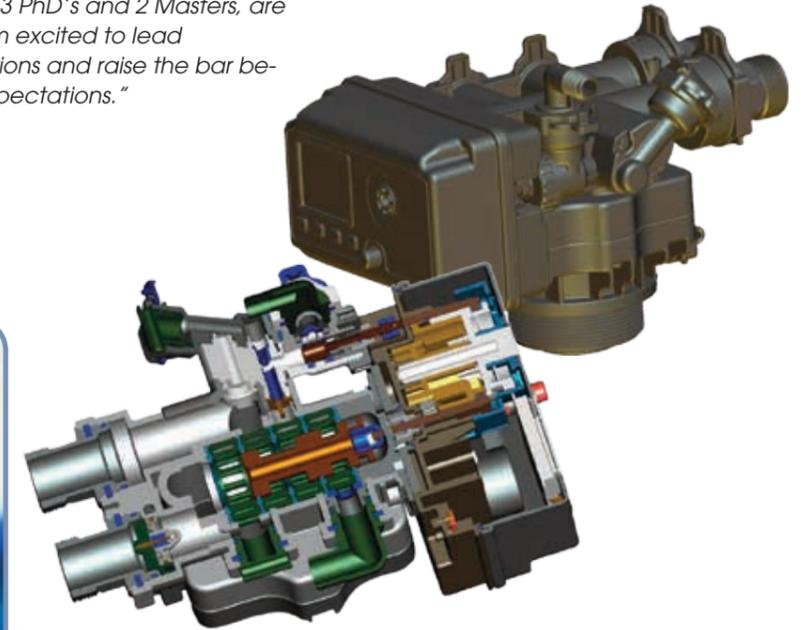

## Water Testing Kits & Sample Bottles



WaterGroup sells a complete line of easy to use test kits so you can accurately test water in the field. Not sure of the proper product application? Give us a call with the results and we'll provide you with a product recommendation. Water Sample Collection Kits are available at Stocking Wholesalers & include a sample bottle, mailing tube and sample collection instructions.

If you have concerns about the safety (potability) of the water supply we recommend a complete water analysis be conducted. These are usually conducted for a small fee at a State or Provincial Lab.

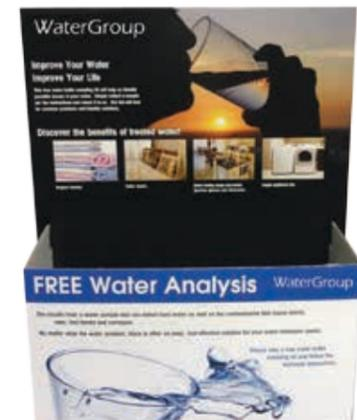

# Control Valves

WaterGroup NSF/ANSI 44 Certified control valves meet or exceed the most vigorous industry performance and reliability standards. Familiar piston, seal and spacer design has been enhanced to improve performance and product life.

The addition of a piston stabilizer reduces the side load force between the piston rod and end plug seal as it firmly guides the piston while it travels up and down. An added rib on the seal improves the sealing pressure so that the valve can withstand over 700psi! These are just a few of the design features that make Novo valves more reliable and better performing. Learn more about the 'Dealer-driven' control valve design features on page 15.

WaterGroup NSF/ANSI 44 Certified control valves meet or exceed competitive equivalents in all four key measures:  
 1) Service Flow Rate, 2) Back Wash Flow Rate, 3) Burst Pressure and 4) Cycle Testing.



Added Rib Improves Seal



Piston Stabilizer

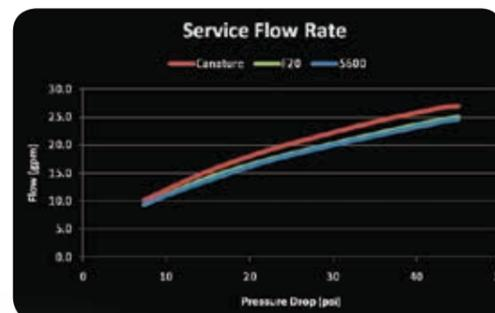
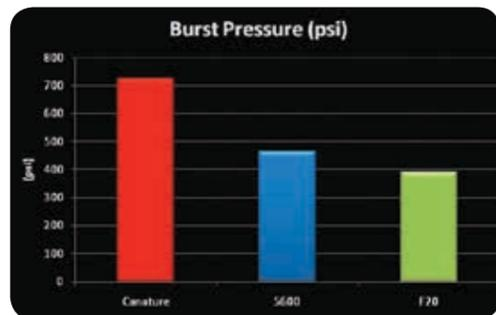
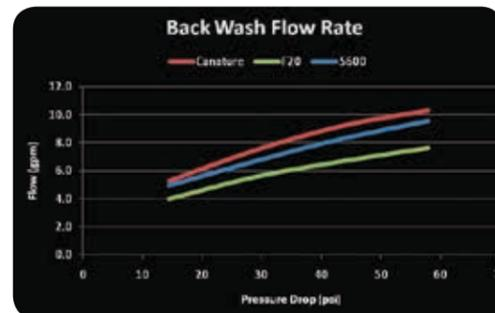
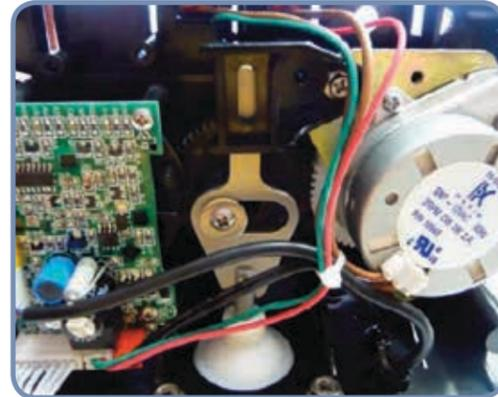

# Fiberglass Tanks

WaterGroup NSF/ANSI 44 Certified filament wound tanks are not only strong and reliable but the finish is unparalleled in the industry. No need for a tank jacket (although we offer those too) with the neatly wound, high gloss finish. Strict tank height control measures mean no surprises when installing a duplex system.

The tanks are made in the World's first and only fully automated, robotic manufacturing process.

Watch the video >>

[www.canaturena.com/tanks-video.asp](http://www.canaturena.com/tanks-video.asp)

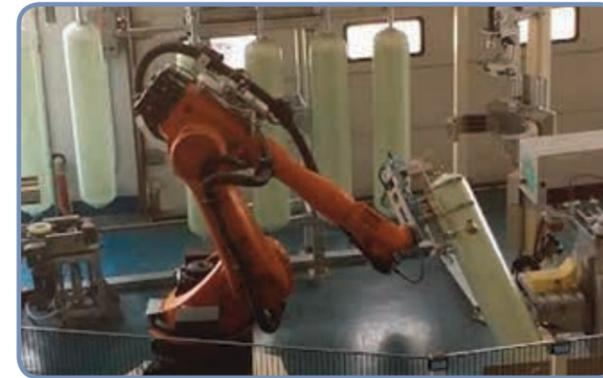
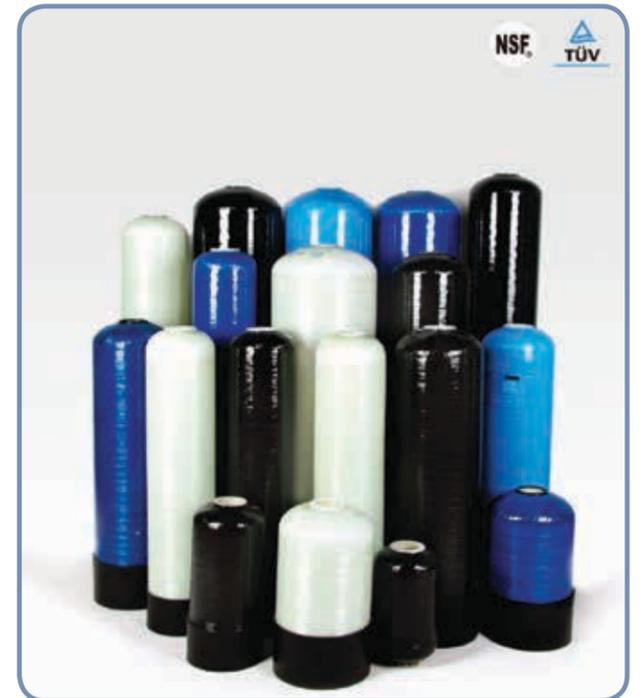

# Assembly, Testing & Distribution

All water softeners and whole-house filters are engineered, assembled, tested and distributed from our North American Regional facilities. All control valves are 100% wet tested and air tested before leaving the factory. Control valves are then set up to engineering specifications for the particular unit, air tested a second time and then assembled into the finished product. All assembled products are packaged in durable, double walled high impact cardboard to ensure products arrive undamaged.



Kyle Stange shrink wrapping shipment in Golden Valley, MN



Mike Cummings assembling a softener in Regina, SK facility



# Quality Assurance Department

WaterGroup employs a strict and formalized quality control program. The 925,000 sq. ft. Shanghai Manufacturing facility is ISO9001:2008 Quality Assurance and ISO 14001:2004 Environmental Management Systems standards certified.

## Quality Control systems:

- ➔ Document Management
- ➔ Receiving Inspection
- ➔ In-process Quality Control
- ➔ Final Inspection
- ➔ Engineering Change Orders
- ➔ First Piece & Production Part Approval
- ➔ Test Equipment Calibration
- ➔ Statistical Process Control
- ➔ Vendor Quality Management
- ➔ Customer Feedback System



## World Class Testing Laboratory

- ➔ **Burst Testing:** High pressure testing of tanks and valves to determine the maximum burst strength.
- ➔ **Cycle Pressure Testing:** High pressure cycling testing to simulate the fatigue strength of the tanks and valves over their life.
- ➔ **Flow Bench:** Precisely measure flow rates and pressure drops.
- ➔ **Reliability Testing:** Continuously cycling the valve through regeneration while taking flow measurements and counting the number of cycles.
- ➔ **Computer Aided Optical Comparator:** Used for precise measurement of very small details such as fillets or radius's.
- ➔ **Coordinate Measuring Machine (Cmm):** Used for precise geometrical x, y, and z measurement coordinates.
- ➔ **3d Prototype Printer:** Makes 3D models for rapid prototyping.
- ➔ **Chemical Analysis Laboratory:** Complete chemical analysis of raw materials including metals, plastics and media to ensure quality and integrity.



# Water Conditioning Basics

The Hydrologic Cycle  
Guidelines for Solving  
Water Problems, Terminology,  
Water Analysis,  
Sizing Parameters

## The Hydrologic Cycle



The total area of the earth is composed of 2/3 water, making it one of the most plentiful and most important materials available. Without potable water, mankind cannot survive.

Pure water consists of two parts hydrogen and one part oxygen, chemically combined to form pure water.

The only pure source of water is the earth's atmosphere (sometimes called the hydrological cycle). Impure water from the earth's oceans, lakes, rivers and surface evaporates into the atmosphere, then condenses to form rain droplets which are totally pure. The above process operates basically the same as a man-made still, which evaporates all the impurities from the water, then returns the condensates into pure water. If this process did not exist, there would likely not be enough potable water to support the earth's population.

"The only pure source of water is the earth's atmosphere."

The pure water vapor, which forms in the earth's atmosphere (clouds), begins to pick up impurities. As it begins to fall to earth in the form of rain, snow, etc., impurities are immediately absorbed. These impurities may be dust, micro-organisms, gases, etc. - at least a little of everything found in the atmosphere on the way to the surface.

The rain or snowfall finds its way to various sources of water supplies on the earth's lakes, rivers, oceans or it may soak into the ground and become a part of an underground stream or lake.

### Characteristics of Various Water Sources

#### Rain Water

After the water picks up impurities in the atmosphere and percolates through the ground, it comes into contact with carbon dioxide and then forms carbonic acid. This dissolves some of the mineral content of the soil or rock it contacts, thus adding these minerals to the water.

#### Surface Water

Water from streams may be turbid due to the presence of silt, clay, etc. However, in larger surface water, a greater amount of self-purification takes place through aerobic digestion, plant life, fish, etc. and the quality of the water could change to a great degree.

#### Ground Water

Normally picks up the minerals it flows through. As a general rule, water from deep wells contains a higher mineral content and is less likely to contain organics or turbidity. Water from shallow wells is usually lower in mineral content and may be subjected to pollution or other bacteria which is available from various sources nearby (e.g. spring run-off through forests and hills, plants, industrial wastes, etc. which will all pass various bacteria into the water).

### Impurities

Impurities in water are divided into two classifications:

#### 1. Dissolved Solids

Those which naturally dissolve into water. NOTE: Gases may also dissolve into water unless they combine chemically with other impurities. They will be released into the atmosphere upon boiling and are not truly classified as dissolved solids. Upon evaporation, only the dissolved solids would remain in the actual mineral form and then can be analyzed by actual weight of the various elements.

#### 2. Suspended Solids

Consist of clay, mud, silt, etc. and will not dissolve into water naturally but remain as such in their present state.

Water treatment and pollution control is one of the largest and most important industries in the modern day world. As can be seen from the preceding information, water treatment is a very broad and varied field and chemical analysis of certain water supplies is virtually impossible to completely break down. In time, modern man may discover additional information regarding the field of water treatment and the entire cycle of the earth's largest and most important single resource.

The following sections will attempt to clarify some of the more common problems and solutions presently available.

# Guidelines for Solving Water Problems

| PROBLEM   | SYMPTOM   | CAUSE  | CORRECTIVE EQUIPMENT  |
|---|---|--|---|
| Hard Water                                      | Spotting on dishes and glassware; scale on inside of water heater, pipes and water-using appliances; soap curd and bathtub ring; clothes look gray and dingy.   | Calcium and magnesium in water, measuring 1.0 gpg or more.   | Water Softener (Max. Hardness 100 gpg) (Max. Clear Water Iron 1.5 ppm)  |
| Clear Water Iron (Ferrous)                      | Yellow, brown or rusty stains on plumbing fixtures, water-using appliances and fabrics; metallic taste in foods and beverages; water is clear when drawn from the faucet but oxidizes when exposed to air, then changes color ranging from yellow to brown. | Iron in the water measuring 0.3 ppm or more.   | 0.3-1.5 ppm Water Softener. 1.5-7.5 ppm SIM Specialty System Softener. 1.5-30 ppm Chemical Free Iron Filter (Note 1).                                   |
| Red Water Iron (Ferric)                         | Same symptoms as Clear Water Iron but iron has already oxidized and has a yellow to rust color when drawn from the faucet.  | Iron in the water measuring 0.3 ppm or more.   | 0.3-30 ppm Chemical Free Iron Filter (Note 1). 0.3-10 ppm Iron & Sulfur Filter.   |
| Bacterial Iron                                  | Same symptoms as Clear & Red Water Iron but can have clumps or balls that may foul plumbing lines and other water-using appliances; particularly noticeable as a yellow to reddish slime in toilet flush tanks.   | Iron bacteria are a group of bacteria which thrive in ironbearing water, utilizing iron as an energy source. This bacteria is not a health hazard. | Chemical Free Iron Filter (Note 1). Chemical feed pump feeding chlorine followed by a Multimedia Filter (Note 3).                                       |
| Manganese                                       | Blackish stain on fixtures and laundry; manganese content above 0.05 ppm causes stains.   | Interaction of carbon dioxide or organic matter with manganesebearing soils. Usually found in combination with iron.                               | 0.05-1.0 ppm Chemical Free M Iron Filter (Note 1). 1.0-2.0 ppm Neutralizing Filter followed by Iron & Sulfur Filter (Note 2).                           |
| Acid Water                                      | Blue/green or rusty stains and corrosion of plumbing fixtures and other water-using appliances; pitting of porcelain and enamel fixtures and dishes. Pin holes in copper plumbing lines.  | Generally associated with water with a pH value of less than the neutral 7.0.  | pH 6.0-6.9 Neutralizing Filter. pH 4.0-6.9 Chemical Feed Pump feeding soda ash. Consult our Customer Service Dept.                                      |
| Aggressive/Corrosive Water                      | Same symptoms as Acid Water but pH is 7.0 or higher.  | Alkalinity and carbon dioxide or high dissolved oxygen in water. Electrolysis - two dissimilar metals in plumbing lines.                           | Consult our Customer Service Dept.  |
| Hydrogen Sulfide                                | Rotten egg taste and/or odor. Turns copper plumbing lines black. Very corrosive.  | Hydrogen sulfide is a dissolved gas found in some water supplies.  | 0.1-3.0 ppm Chemical Free Iron Filter or Iron & Sulfur Filter. 3.0-15 ppm Chemical Feed Pump feeding chlorine followed by a Multimedia Filter (Note 3). |
| Marshy, metallic or chlorine taste and/or odors | Objectionable tastes and/or odors other than hydrogen sulfide.  | Dissolved minerals or gases; organic contamination or chlorination.  | Activated Carbon Filter for whole house water supply or Taste & Odor Cartridge Filter for individual faucets.   |
| Turbidity (Sand/Sediment)                       | Foreign particles, dirty or cloudy water.   | Tiny suspended particles that are the result of water main scale or silt. Private wells often contain sand or clay.                                | Multimedia Filter for whole house water supply or a Sediment Cartridge Filter for individual faucets.   |
| Tannins   | Yellow or brown tint or cast in water supply; tannins measuring 0.5 ppm or higher may cause staining and/or interference with various water treatment processes.  | Result of decaying vegetative matter.  | Organic Color Removal Filter. Consult our Customer Service Dept.  |

**Note 1** - Water must have a minimum pressure of 20 psi, pumping rate of 5 gpm and a pH of 6.5 or higher for proper operation. Most water supplies contain calcium and magnesium which are not removed by an iron filter. We recommend following an iron filter with a water softener.

**Note 2** - Oxidation of manganese is more pH dependent than iron. Therefore a pH of 8.2 or higher must be maintained. If the manganese level is >2.0 ppm or bacterial iron is present, consult our Customer Service Department.

**Note 3** - This system also requires a retention tank to allow adequate contact time (minimum 20 minutes). An optional activated carbon filter for the whole house water supply or a taste & odor cartridge filter for individual faucets may be installed to remove any objectionable taste or odor.

# Terminology

## Grains per Gallon - gpg

1/7000 of a pound - normally used in relation to hardness.

## Parts per Million - ppm

One part dissolved material in one million parts of water. Used as a measurement for iron, manganese, TDS, hydrogen sulfide, chlorides, sulfates and tannins.

## Milligrams per Liter - mg/l

For our purpose, same as ppm. Normally used for a more accurate measurement or where small quantities of certain elements cause big problems in relation to iron, manganese, sulfur, nitrates and silica.

## Converting gpg to ppm or mg/l

1 gpg = 17.1 ppm (mg/l)

## Total Dissolved Solids - TDS

The weight of solids, per unit volume of water, which are in true solution. Can be determined by the evaporation of a measured volume of filtered water and determination of the residue weight. A common alternative method to determine TDS is to measure the conductivity of water.

## Hardness

A characteristic of natural water due to the presence of dissolved calcium and magnesium. Water hardness is responsible for most scale formation in pipes and water heaters and forms insoluble "curd" when it reacts with soaps. Hardness is usually expressed in grains per gallon (gpg), parts per million (ppm) or milligrams per liter (mg/l), all as calcium carbonate equivalent.

## Ferric Iron

Iron that is oxidized in water and is visible. Also called red water iron.

## Ferrous Iron

Iron that is dissolved in water. Also called clear water iron.

## pH

pH is a measure of the intensity of the acidity or alkalinity of water on a scale from 0 to 14, with 7 being neutral. When acidity is increased, the hydrogen ion concentration increases, resulting in a lower pH value. Similarly, when alkalinity is increased, the hydrogen ion concentration decreases, resulting in higher pH.

The pH value is an exponential function so that pH 10 is 10 times more alkaline than pH 9 and 100 times more alkaline than pH 8. Similarly, a pH 4 is 100 times more acid than pH 7.

## pH Scale

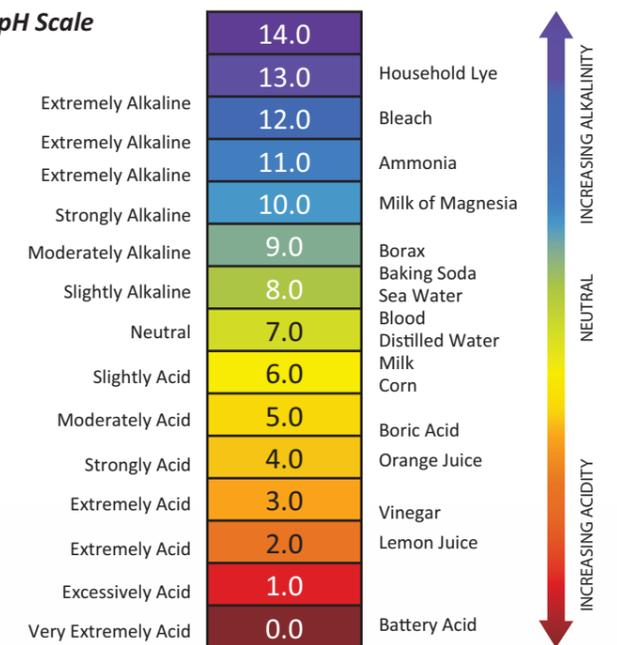

**Note:** A complete glossary can be found in the Water Conditioning Glossary section.



# Water Analysis

For correct sizing and application of water conditioning equipment, a water analysis is required. A basic water analysis includes tests for the following:

- **Hardness**
- **Iron**
- **Manganese**
- **pH**
- **TDS (Total Dissolved Solids)**

Water samples should be taken as near the source as possible and represent the average water condition. Clean containers must be used. When performing the analysis, the test equipment must be clean and rinsed with the test water and the test water should be between 68°F and 77°F (20°C and 25°C). Use rubber stops as supplied. Do not use your fingers as contaminants and acids could affect test results.

Additional tests can be performed for tannins and hydrogen sulfide (H<sub>2</sub>S). The test for H<sub>2</sub>S must be performed on-site for accurate results. Special tests can be performed for chlorides, sulfates and alkalinity by specified laboratories. If it is suspected the water supply is contaminated with coliform bacteria or nitrates, a sample must be collected in an approved sterilized container and submitted to a government approved laboratory. Iron bacteria will not be detected with the standard iron test and can be tested for by a government approved laboratory.

If the TDS is over 1000 ppm and hardness is less than 30% of the TDS, a complete water analysis should be performed to discover what other contaminants exist in the water.

If a contaminant exceeds the limits detectable by any test method, the raw water sample can be diluted with distilled water until a reading can be taken. A calculation must then be performed to determine the actual degree of contamination. All test chemicals are subject to age and extreme temperatures. Proper storage techniques and expiry dates should be observed.

The Water Analysis Report shown on the next two pages must be completed accurately to determine the correct equipment to recommend for the water problem(s) being experienced.

## Hard Water

Water with a total hardness of 1.0 gpg or more as calcium carbonate equivalent.

|                          |                 |
|--------------------------|-----------------|
| Less than 1.0 gpg .....  | Soft            |
| 1.0 - 3.5 gpg .....      | Slightly hard   |
| 3.5 - 7.0 gpg .....      | Moderately hard |
| 7.0 - 10.5 gpg .....     | Hard            |
| More than 10.5 gpg ..... | Very hard       |

## Hardness

A characteristic of natural water due to the presence of dissolved calcium and magnesium. Water hardness is responsible for most scale formation in pipes and water heaters and forms insoluble "curd" when it reacts with soaps. Hardness is usually expressed in grains per gallon (gpg), parts per million (ppm) or milligrams per liter (mg/l) all as calcium carbonate equivalent.

## Soft Water

Any water which contains less than 1.0 gpg (17.1 mg/l) of hardness minerals, expressed as calcium carbonate equivalent.

## Softened Water

Any water that is treated to reduce hardness minerals, expressed as calcium carbonate equivalent.

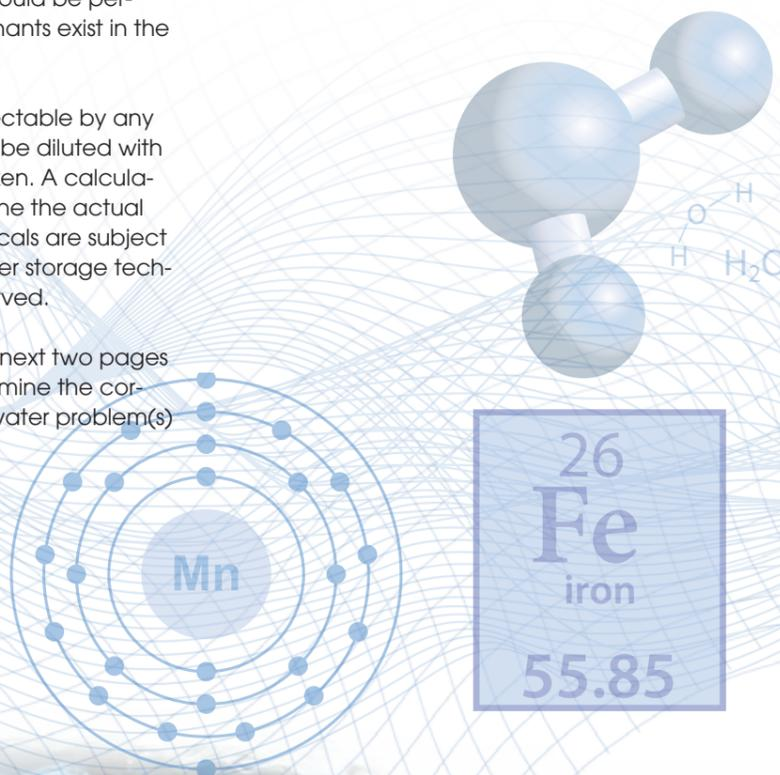

# WaterGroup

## Water Analysis Report

FOR LABORATORY USE ONLY

Date Received \_\_\_\_\_

Report No. \_\_\_\_\_

Date Completed \_\_\_\_\_

NOTE: Please answer ALL appropriate questions to ensure accurate equipment recommendations

### CUSTOMER

Name \_\_\_\_\_

Street \_\_\_\_\_

Town \_\_\_\_\_ State/Province \_\_\_\_\_

Zip Code/P.C. \_\_\_\_\_ Email \_\_\_\_\_

Phone \_\_\_\_\_ Fax \_\_\_\_\_

### DEALER

Name \_\_\_\_\_

Street \_\_\_\_\_

Town \_\_\_\_\_ State/Province \_\_\_\_\_

Zip Code/P.C. \_\_\_\_\_ Email \_\_\_\_\_

Phone \_\_\_\_\_ Fax \_\_\_\_\_

### DISTRIBUTOR

Name \_\_\_\_\_

Street \_\_\_\_\_

Town \_\_\_\_\_ State/Province \_\_\_\_\_

Zip Code/P.C. \_\_\_\_\_ Email \_\_\_\_\_

Phone \_\_\_\_\_ Fax \_\_\_\_\_

**Bacterial analysis must be performed by your local health department.**

### HOW TO DRAW WATER SAMPLE

Use outlet nearest pump (not from bottom of pressure tank). Run water for five minutes or two pump cycles, then fill clean bottle to neck and cap immediately. Never use hot water. Return bottle with this completed form.

### HOW TO MEASURE PUMPING RATE OF PUMP

1. Make certain no water is being drawn. Open spigot nearest pressure tank. When pump starts, close tap and measure time (in seconds) to refill pressure tank. This is **cycle time**.
2. Using a container of known volume, draw water and measure volume in gallons until pump starts again. This is **drawdown**.
3. Divide drawdown by cycle time and multiply the result by 60 to arrive at the **pumping rate** in gallons per minute. Insert this figure in #3 Water System.

### 1. Water Source

- City or area-wide authority
- Community water system (small water system usually supplying 12 homes or fewer)
- Water comes from:
  - Well  Lake  Reservoir  River  Unknown
  - New private well - Approx age \_\_\_\_\_ months
  - Old private well - Approx age \_\_\_\_\_ months
  - Private lake  Private spring  Private dugout
  - Private cistern  Other - describe \_\_\_\_\_

### 2. Household Information

- Do you now have water conditioning equipment?
- No  Yes Type \_\_\_\_\_ Size \_\_\_\_\_
  - Single family  Multi-family No. of units \_\_\_\_\_
  - No. persons \_\_\_\_\_ No. baths \_\_\_\_\_
  - Lawn irrigation on water system?
  - Indoor pool  Outdoor pool - Capacity \_\_\_\_\_ gallons
  - Water line size from source - \_\_\_\_\_ inches

### 3. Water System

- Type of Pump**
- Constant Pressure  Jet  Submersible  Unknown
  - Pumping rate of pump \_\_\_\_\_ gpm

**Pressure Tank**

  - Air to water  Bladder Capacity \_\_\_\_\_ gallons
  - Operating pressure (low/high) \_\_\_\_\_ / \_\_\_\_\_ psi

### 4. Water Problems

- When this sample was drawn, it was:
- Clear  Colored  Cloudy
  - This water sample is  Untreated  Treated
  - How is it treated? \_\_\_\_\_

### PROBLEMS

- Hardness (e.g. high soap usage, bathtub ring, lime deposits, etc.)
- Iron Deposits - if so, is iron build-up in flush tank?
- Greasy  Gritty  Stringy (iron bacteria?)
- Color of Water -  Red  Orange  Black
- Greenish or blue stains on sinks, tubs, etc.
- Pitting of fixtures and/or pipes
- Sand (visible particles)  Sediment or silt (cloudy)
- Bad Taste -  Iron  Bitter  Salty
- Other - describe \_\_\_\_\_
- Bad Odor -  Rotten Egg  Musty  Iron
- Odor is in -  Cold Water  Hot Water  Both
- Other Problems - describe \_\_\_\_\_

**5. Standard Laboratory Tests**

|                        |       |      |
|------------------------|-------|------|
| Total Hardness         | _____ | gpg  |
| Iron                   | _____ | mg/l |
| Manganese              | _____ | mg/l |
| pH                     | _____ |      |
| Total Dissolved Solids | _____ | mg/l |

**6. Other Tests**

|  |       |      |
|--|-------|------|
| Hydrogen Sulfide<br>(test must be performed on-site) | _____ | mg/l |
| Tannins  | _____ | mg/l |

**7. Special Laboratory Tests**

|            |       |      |
|------------|-------|------|
| Chlorides  | _____ | mg/l |
| Sulfates   | _____ | mg/l |
| Alkalinity | _____ | mg/l |

**If TDS is over 1000 ppm and hardness is less than 30% of the TDS, a total water analysis is required.**

**8. Explanation of Water Analysis**

**A. Total Hardness**

This indicates the efficiency or workability of the water for everyday household use. Water in excess of 3 gpg is generally considered hard and should be softened.

**B. Iron**

Over 0.3 ppm of iron will cause discoloration of water and staining. Fully automatic water conditioners will correct this problem. Some extreme water situations may require filtration.

**C. Manganese**

Manganese is frequently encountered in iron-bearing water but to a lesser degree. Manganese is similar to iron in that it stains and clogs pipes and valves. Concentrations as low as 0.05 mg/l of manganese can cause problems.

**D. pH**

A scale used to measure the acidity or alkalinity of water. A pH reading below 6.5 normally indicates highly corrosive water and neutralizing equipment should be used. A pH reading in excess of 8.5 could indicate contaminated water and generally requires bacteriological and chemical analysis.

**E. Hydrogen Sulfide (H<sub>2</sub>S)**

Testing for hydrogen sulfide should occur on-site. Hydrogen sulfide imparts a rotten egg odor and taste that makes water all but undrinkable and also promotes corrosion. In addition, it can foul the resin bed of a water conditioner. The use of a water conditioner is not recommended unless the water is first treated for the removal of hydrogen sulfide.

**F. Total Dissolved Solids (TDS)**

A measure of the soluble solids present in the water.

**G. Tannins**

Tannic acid is formed by decaying organic matter. Tannins alone are not harmful, although they can affect the proper operation of a chemical free iron filter.

**H. Chlorides**

Over 500 ppm may impart a salty taste to water.

**I. Sulfates**

Over 500 ppm may impart a bitter taste to water and have a slight laxative effect.

**J. Alkalinity**

Caused by the presence of bicarbonates, carbonates and hydroxides. Over 500 ppm creates a "soda" taste and makes skin dry.

**Recommendations**

Recommendations are based entirely on the information supplied and the water sample chemistry results at the time of analysis.

---



---



---



---

Recommended by \_\_\_\_\_

Date \_\_\_\_\_

Return completed form to:



# Sizing Parameters

## Water Softener Sizing is Based On

- ➔ 60 gallons per person per day - total household use
- ➔ Three day minimum between regenerations
- ➔ Capacity between regenerations at factory salt settings or K label capacity
- ➔ Number of people x 60 gallons per person x gpg of hardness x 3 days = capacity required between regenerations
- ➔ Consult your factory representative for water that is 75 gpg or harder

## Water Softener/Iron Removal Combination Units

- ➔ This unit should be recommended only when dictated by special circumstances or the needs of the customer.
- ➔ The customer should be made aware that a separate iron filter and softener is preferred because it is a more efficient way to deal with the water.
- ➔ When recommending a combination unit, follow the guidelines provided in the specifications.

## Water Consumption for Regeneration

The volume of water used during the regeneration process of a water softener will vary depending on:

- ➔ Amount and type of resin
- ➔ Cycle time settings
- ➔ Flow controllers
- ➔ Salt settings
- ➔ Tank diameter

Generally, water usage for regeneration is based on the cubic feet of resin per water softener from a low of 30 gallons of water per cubic foot, up to a normal of 75 gallons of water per cubic foot, to a maximum of 100 gallons of water per cubic foot. Manufacturing specs and settings for each model size should be checked to verify exact amounts.

## Three Day Sizing Method

The three day sizing method is used for the following reasons:

1. To determine the size of the water conditioner to be used
2. To allow for reserve capacity between regenerations so the customer does not run out of soft water
3. To provide the most economical operation cost

## Conversion Factors & Compensated Iron & Manganese

Total Hardness converted from ppm or mg/l to Grains/US Gallon (gpg)  
**ppm (mg/l) ÷ 17.1 = gpg**

If there is a small amount of Iron or Manganese in the water, add the following compensated values:  
**Iron - ppm x 4**  
**Manganese - ppm x 8**  
 To arrive at the additional compensated load on the softener

The Total Equivalent Iron for the softener to remove should not be greater than 1.5 ppm. Total Equivalent Iron is calculated as follows:  
**Iron ppm + 2 x Manganese ppm < 1.5 ppm**

If the Total Equivalent Iron is less than 0.5 ppm, a Res-Up Feeder and Pro ResCare can be added as an optional safeguard against fouling or the bed can be cleaned occasionally by adding a small amount to the brine tank manually.

If the Total Equivalent Iron is 0.5 - 1.5 ppm, the softener can be sized accordingly but a Res-Up Feeder and Pro ResCare is required in addition to the softener to prevent iron fouling of the resin.

If the Total Equivalent Iron is greater than 1.5 ppm, an Iron Filter is required as pretreatment prior to the softener.

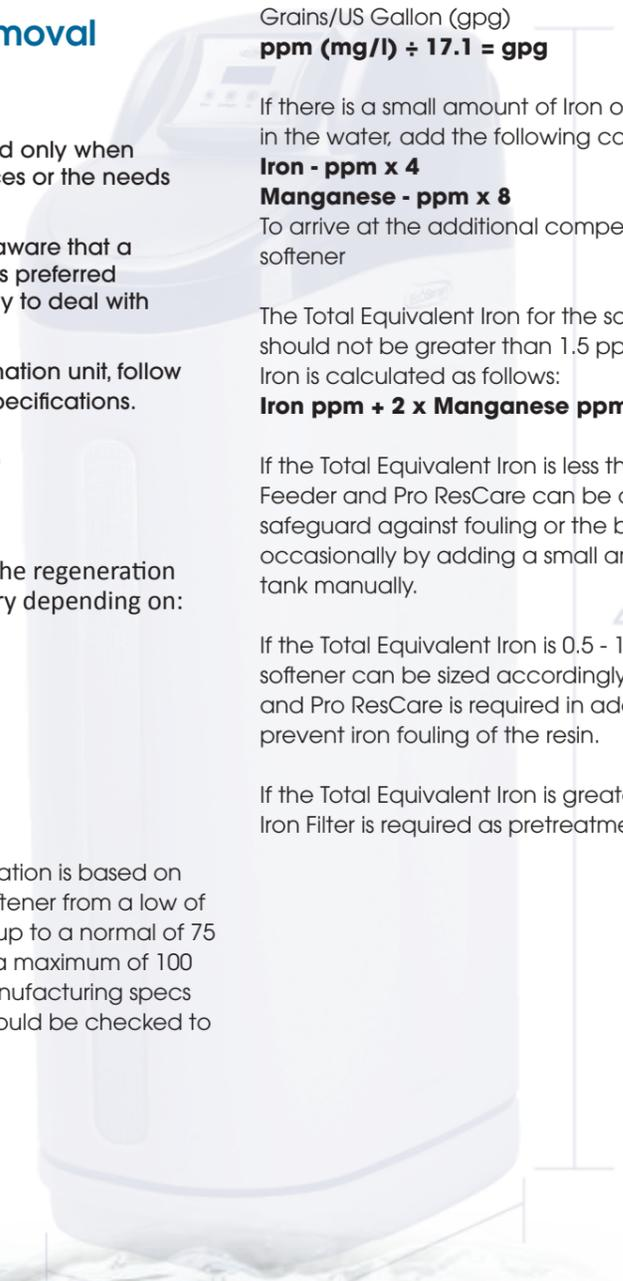

# Unique Features Designed with the Plumber in Mind

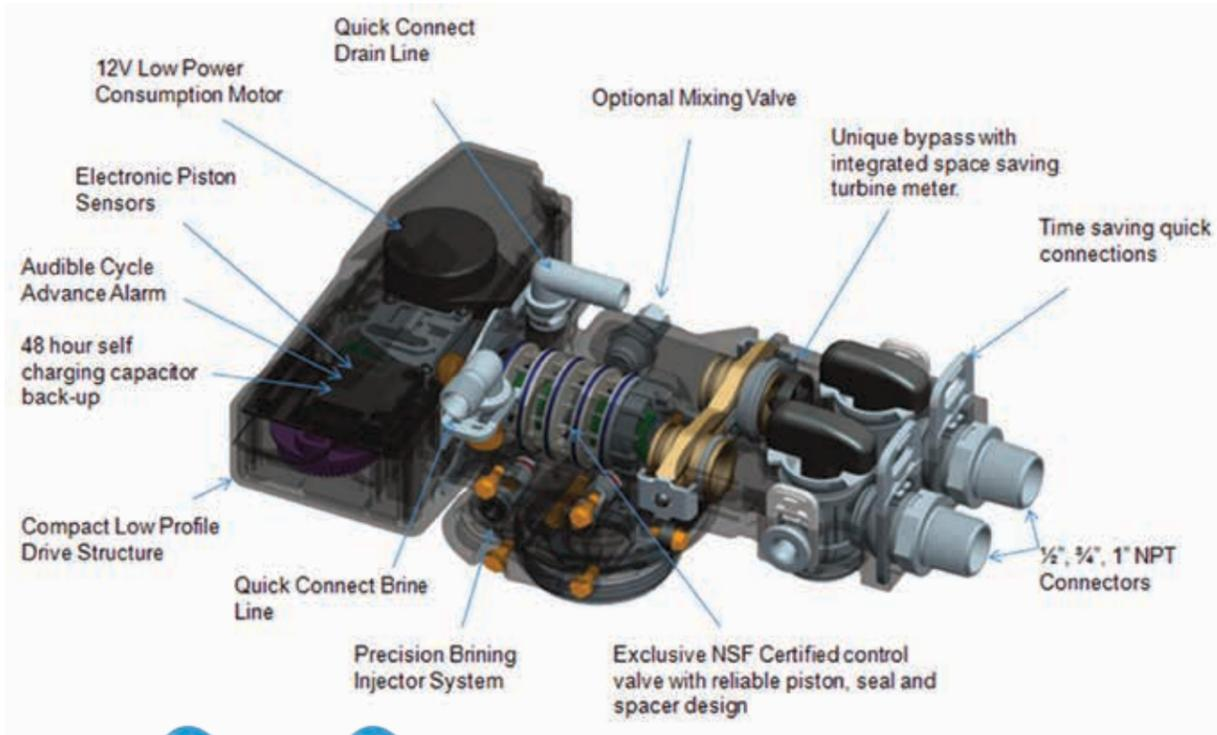

## Quick Connect Features for Ultimate Convenience

The quick connect bypass comes with both 3/4" 90 degree elbows and 1" straight NPT adaptors. Optional quick connect adaptors include 3/4" straight SharkBite and 3/4" NPT adaptors.



All units include pre-installed bypass



Standard QC Fittings



Optional Fittings



3/4" FIP x 3/4" Jg Flex Connector 18" (Item # 80127757)  
Simply push to connect on to any 3/4" copper, CPVC or PEX piping with no tools!! Brought to you by a collaboration between Falcon Stainless and John Guest USA. Eliminates the need for expensive brass compression fittings or copper male adaptors.



## Softeners, Filters & Specialty Systems

# Space Saving Improved Design

Eliminate 4" and unnecessary connections for neat, quick installations. Bypass with integrated meter avoids 'meter jamming' which is caused from weight of pipes creating torque on turbines causing them to bind and stop metering.

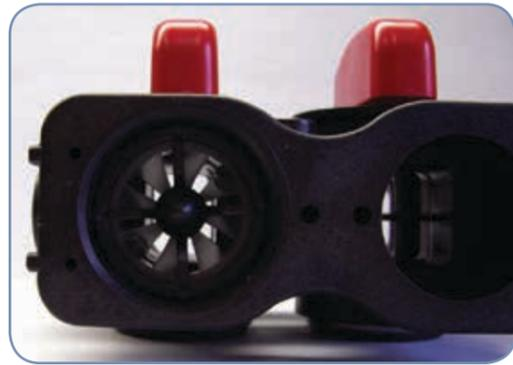

integrated meter in bypass

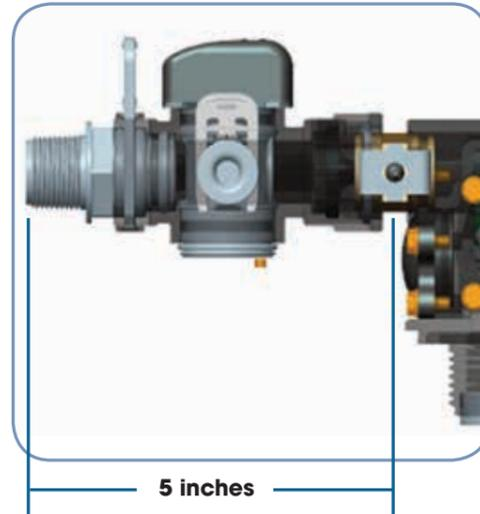

1 Connection Comes pre-installed

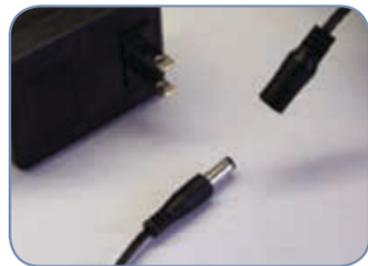

QC Power Cable

- ➔ Simplifies installation or removal of the valve from the tank
- ➔ No tangled or wrapped up power cords!



Competitive Valve

9 inches  
3 Connections

## High Quality Brine Components

- ➔ Closed bottom brine well reduced intrusion of unwanted impurities
- ➔ Injection molded brine grids reduce bridging
- ➔ Solvent free distributor tube with spun weld collector avoids glue and solvents
- ➔ Injection molded reliable brine valve



# Heavy Duty Packaging

WaterGroup uses only durable double-walled high impact cardboard with carrying straps to ensure you do not have to deal with the headache of receiving damaged products.



"Our focus is to build the highest quality water conditioning products in the industry... so when it comes to protecting them from damage during shipping & handling we don't 'cheap out'"

Toby Hughes, P.Eng  
Chief operations officer



## Water Softener Sizing Guide

### Choosing the Right Size Softener

| # of People | Total Hardness (Grains per Gallon) |                |                |                |                |                |                |                |                |                |                |
|-------------|------------------------------------|----------------|----------------|----------------|----------------|----------------|----------------|----------------|----------------|----------------|----------------|
|             | 10                                 | 15             | 20             | 25             | 30             | 40             | 50             | 60             | 70             | 75             |                |
| 1           | WG185 24 EF 20                     | WG185 24 EF 20 | WG185 24 EF 20 | WG185 24 EF 20 | WG185 24 EF 20 | WG185 24 EF 20 | WG185 24 EF 20 | WG185 24 EF 20 | WG185 24 EF 20 | WG185 32 EF 30 | WG185 32 EF 30 |
| 2           | WG185 24 EF 20                     | WG185 24 EF 20 | WG185 24 EF 20 | WG185 24 EF 20 | WG185 24 EF 20 | WG185 24 EF 20 | WG185 24 EF 30 | WG185 24 EF 30 | WG185 32 EF 30 | WG185 32 EF 40 | WG185 40 EF 60 |
| 3           | WG185 24 EF 20                     | WG185 24 EF 20 | WG185 24 EF 20 | WG185 24 EF 20 | WG185 24 EF 20 | WG185 32 EF 30 | WG185 40 EF 60 | WG185 40 EF 60 | WG185 60 EF 60 | WG185 60 EF 60 | WG185 60 EF 60 |
| 4           | WG185 24 EF 20                     | WG185 24 EF 20 | WG185 24 EF 20 | WG185 24 EF 30 | WG185 32 EF 30 | WG185 40 EF 60 | WG185 60 EF 60 | WG185 60 EF 60 | WG185 60 EF 90 | WG185 90 EF 90 | WG185 90 EF 90 |
| 5           | WG185 24 EF 20                     | WG185 24 EF 20 | WG185 32 EF 30 | WG185 32 EF 40 | WG185 40 EF 60 | WG185 60 EF 60 | WG185 60 EF 90 | WG185 60 EF 90 | WG185 90 EF 90 | WG185 90 EF 90 | WG185 90       |
| 6           | WG185 24 EF 20                     | WG185 24 EF 30 | WG185 32 EF 40 | WG185 40 EF 60 | WG185 60 EF 60 | WG185 60 EF 90 | WG185 90 EF 90 | WG185 90       | WG185HEDP100   | WG185HEDP100   | WG185HEDP100   |
| 7           | WG185 24 EF 20                     | WG185 24 EF 30 | WG185 40 EF 40 | WG185 60 EF 60 | WG185 60 EF 60 | WG185 60 EF 90 | WG185 90       | WG185HEDP100   | WG185HEDP100   | WG185HEDP125   | WG185HEDP125   |
| 8           | WG185 24 EF 20                     | WG185 32 EF 30 | WG185 40 EF 60 | WG185 60 EF 60 | WG185 60 EF 60 | WG185 90 EF 90 | WG185 90       | WG185HEDP100   | WG185HEDP125   | WG185HEDP125   | WG185HEDP125   |
| 9           | WG185 24 EF 30                     | WG185 40 EF 40 | WG185 60 EF 60 | WG185 60 EF 60 | WG185 90 EF 90 | WG185 90       | WG185HEDP100   | WG185HEDP125   | WG185HEDP125   | WG185HEDP125   | WG185HEDP125   |
| 10          | WG185 32 EF 30                     | WG185 40 EF 60 | WG185 60 EF 60 | WG185 60 EF 90 | WG185 90 EF 90 | WG185HEDP100   | WG185HEDP100   | WG185HEDP125   | WG185HEDP125   | WG185HEDP125   | WG185HEDP125   |

Notes: We recommend contacting Novo Water Customer Service for any hardness levels above 75 gpg for proper recommendations  
NVO165-N/A models indicate the equivalent 465 model should be used in that application  
Cabinet models are available for all 75 and 100 models

# WG185UF Series Water Softener

## WG185UF: High-Efficiency Performance for the Lowest Salt & Water Usage Ever!



Uses **75% Less Salt**  
**67% Less Water\***

### Features:

- ➔ Exclusive WG 185UF NSF Certified electronic control valve with reliable piston, seal and spacer technology
- ➔ Cabinet or Twin Tank models
- ➔ User-friendly backlit LCD display
- ➔ "No Touch" information display rotates key info like last regeneration date and volume remaining
- ➔ 48 hour memory back-up
- ➔ Meter Immediate, Meter Delayed, Meter Override, and Calendar Clock mode
- ➔ Adjustable cycle times
- ➔ Brine safety valve provides extra overflow protection
- ➔ Unique bypass with an integrated space saving turbine meter and sample ports on the inlet. One-piece design avoids meter jamming.
- ➔ Time saving quick connect fittings on bypass, drain and brine line. Power cord even has quick connect for easy valve spin on.
- ➔ Drain line o-ring eliminates need for Teflon
- ➔ Condensation tank jacket (twin tank models)
- ➔ Hose clamp and 10' of drain tubing included
- ➔ WQA Tested & Certified to NSF/ANSI 44 for effective reduction of hardness as verified and substantiated by test data.

### All Systems Include:

- ➔ **NSF Certified** pressure tank
- ➔ **NSF Certified** control valve
- ➔ **WQA Gold Seal Certified** cation resin
- ➔ **Pre-installed** bypass
- ➔ **Injection molded** brine grids (twin tanks only)

\* Compared to conventional calendar clock models

**Injection molded brine grid reduces bridging**



# High Performance Features:

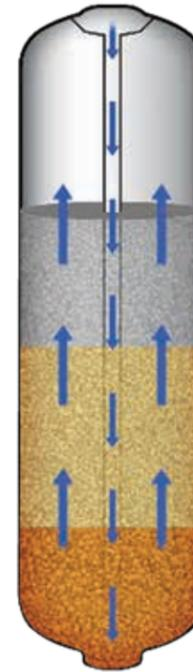

### Reverse Flow Regeneration with Precision Brining

Traditional 'downflow' softeners deplete the unused portion of the resin bed with every regeneration. It is like draining the gas tank in your car every time before filling it up!

'Reverse Flow Regen' - drives the hardness minerals up through the already depleted resin and out to drain - saving both salt and the unused portion of the resin for future use.

**Precision Brining** - saves additional salt by pre-making only 70% of the brine. Just before regeneration, the computer calculates the precise amount of brine top-up needed to regenerate only the depleted resin saving up to 30% more salt!

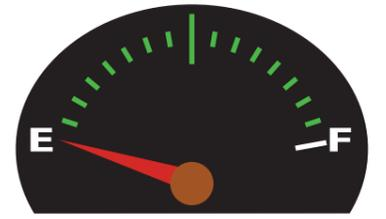

- ➔ **Municipal Backwash Cycle Preset** reduces back wash frequency for clean water supplies
- ➔ **Sanitary System Flush** flushes stagnant water after 7 days of non-use preventing bacteria growth
- ➔ **Soft Water Quick Charge Mode** ensures soft water during unusually heavy water usage
- ➔ **Soft Water Brine Tank Refill** keeps tank & injectors clean

### Estimated Annual Back Wash Water Usage

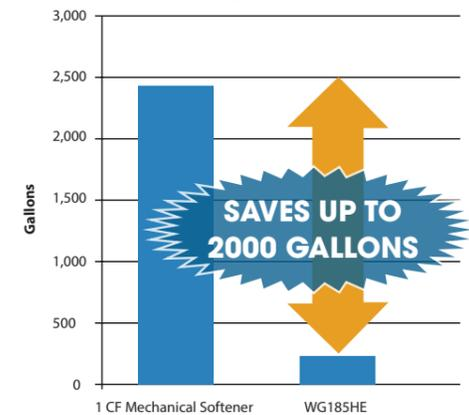

## ULTIMATE SALT & WATER SAVINGS!

Use 75% Less Salt & 64% Less Water! It's good for you & good for the environment!

### Salt Used Per Year

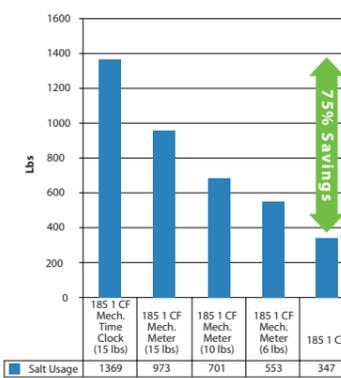

### Estimated Regeneration Water Used Per Year

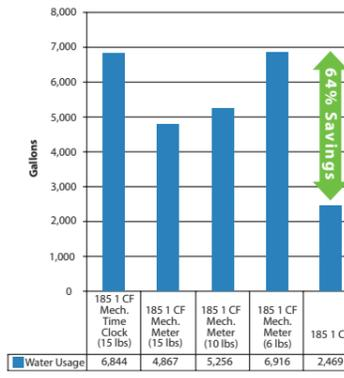

### Estimated Annual Operating Cost (Salt + Water)

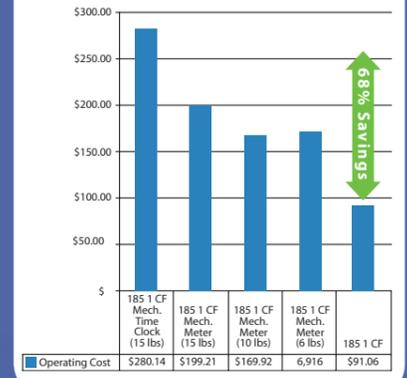

WQA Tested & Certified to NSF/ANSI 44 for effective reduction of hardness as verified and substantiated by test data.

# 185 Water Softener Specifications

| Specifications                              | WG185UF24C                                   | WG185UF32C         | WG185UF24   | WG185UF32   | WG185UF40   | WG185UF60   | WG185UF90   |
|---|--|--------------------|-------------|-------------|-------------|-------------|-------------|
|   | 2130   | 2131               | 2132        | 2133        | 2134        | 2135        | 2136        |
| <b>Optional Settings - High Efficiency</b>  |  |                    |             |             |             |             |             |
| Salt Used - Per Regeneration                | 2.3 lbs                                      | 3.0 lbs            | 2.3 lbs     | 3.0 lbs     | 3.75 lbs    | 6.0 lbs     | 9.0 lbs     |
| Water Used - Regeneration                   | 22.7 gal                                     | 28.3 gal           | 22.6 gal    | 31.6 gal    | 39.5 gal    | 60.9 gal    | 102.2 gal   |
| Hardness Removal - Grains                   | 11,250                                       | 15,000             | 11,250      | 15,000      | 18,750      | 30,000      | 45,000      |
| <b>Factory Settings - Standard Capacity</b> |  |                    |             |             |             |             |             |
| Salt Used - Per Regeneration                | 4.5 lbs                                      | 6.0 lbs            | 4.5 lbs     | 6.0 lbs     | 7.5 lbs     | 12.0 lbs    | 18.0 lbs    |
| Water Used - Regeneration                   | 40.5 gal                                     | 48.6 gal           | 34.0 gal    | 43.4 gal    | 54.3 gal    | 87.1 gal    | 139.2 gal   |
| Hardness Removal - Grains                   | 18,750                                       | 25,000             | 18,750      | 25,000      | 31,250      | 50,000      | 75,000      |
| <b>Optional - High Capacity</b>             |  |                    |             |             |             |             |             |
| Salt Used - Per Regeneration                | 7.5 lbs                                      | 10.0 lbs           | 7.5 lbs     | 10.0 lbs    | 12.5 lbs    | 20.0 lbs    | 30.0 lbs    |
| Water Used - Regeneration                   | 56.1 gal                                     | 69.5 gal           | 49.6 gal    | 64.3 gal    | 80.37 gal   | 124.6 gal   | 196.2 gal   |
| Hardness Removal - Grains                   | 22,500                                       | 30,000             | 22,500      | 30,000      | 40,000      | 60,000      | 90,000      |
| Resin Quantity - Cubic Feet                 | 0.75 ft                                      | 1.0 ft             | 0.75 ft     | 1.0 ft      | 1.25 ft     | 2.0 ft      | 3.0 ft      |
| Tank Size                                   | 9x35   | 10x35              | 9x35        | 10x35       | 10x47       | 12x52       | 14x65       |
| Tank Jacket / Media Loaded                  | Yes  | Yes                | Yes         | Yes         | Yes         | No          | No          |
| Brine Tank / Cabinet Size (Inches)          | 16.5 x 19.3 x 43.3                           | 16.5 x 19.3 x 43.3 | 18.1 x 34.5 | 18.1 x 34.5 | 18.1 x 34.5 | 20.3 x 37.4 | 23.0 x 40.5 |
| Salt Storage Capacity                       | 175 lbs                                      | 175 lbs            | 240 lbs     | 240 lbs     | 240 lbs     | 350 lbs     | 420 lbs     |
| Flow Rate @ 15 psi Pressure Drop            | 11.6 gpm                                     | 12.0 gpm           | 10.4 gpm    | 11.0 gpm    | 12 gpm      | 12.2 gpm    | 12.6 gpm    |
| Flow Rate @ 25 psi Pressure Drop            | 15.6 gpm                                     | 16.0 gpm           | 14.3 gpm    | 15.0 gpm    | 15.5 gpm    | 16.2 gpm    | 16.6 gpm    |
| Back Wash Flow Rate                         | 2.0 gpm                                      | 2.4 gpm            | 1.5 gpm     | 2.0 gpm     | 2.4 gpm     | 3.5 gpm     | 5.0 gpm     |
| Shipping Weight                             | 93 lbs                                       | 110 lbs            | 105 lbs     | 122 lbs     | 154 lbs     | 172 lbs     | 244 lbs     |
| Regeneration Type                           | Counter Current / Up Flow                    |                    |             |             |             |             |             |
| Maximum Efficiency                          | 5,060 grains / lb salt                       |                    |             |             |             |             |             |
| Plumbing Connections                        | Includes 3/4" 90° Elbows & 1" Straight NPT   |                    |             |             |             |             |             |
| Resin Type                                  | Canature 8% High Capacity Ion Exchange Resin |                    |             |             |             |             |             |
| Electrical Requirements                     | Input 120V 60 Hz - Output 12V 650mA          |                    |             |             |             |             |             |
| Water Temperature                           | Min 39 - Max. 100 degrees Fahrenheit         |                    |             |             |             |             |             |
| Water Pressure                              | Min. 20 - Max. 125 psi                       |                    |             |             |             |             |             |



# WG185DF Series Water Softener

## Mid Efficiency with Added Features

Offers a balance of technology and features at a great price point. User-friendly backlit LCD display with "No Touch" information display



\*Compared to conventional calendar clock models

## All Systems Include:

- ▶ NSF Certified pressure tank
- ▶ NSF Certified control valve
- ▶ WQA Gold Seal Certified cation resin

## Features:

- ➔ Exclusive WG 185DF NSF Certified electronic control valve with reliable piston, seal and spacer technology
- ➔ Cabinet or Twin Tank models
- ➔ User-friendly backlit LCD display
- ➔ "No Touch" information display rotates key info like last regeneration date and volume remaining
- ➔ 48 hour memory back-up
- ➔ Meter Immediate, Meter Delayed, Meter Override, and Calendar Clock mode
- ➔ Adjustable cycle times
- ➔ Brine safety valve provides extra overflow protection
- ➔ Unique pre-installed bypass with an integrated space saving turbine meter and sample ports on the inlet. One-piece design avoids meter jamming.
- ➔ Time saving quick connect fittings on bypass, drain and brine line. Power cord even has quick connect for easy valve spin on.
- ➔ Drain line o-ring eliminates need for Teflon
- ➔ Condensation tank jacket (twin tank models)
- ➔ Injection molded brine grids (twin tanks only)
- ➔ Hose clamp and 10' of drain tubing included
- ➔ WQA Tested & Certified to NSF/ANSI 44 for effective reduction of hardness as verified and substantiated by test data.

| Specifications                              | WG185DF24C                                   | WG185DF32C         | WG185DF24   | WG185DF32   | WG185DF40   | WG185DF60   | WG185DF90   |
|---|--|--------------------|-------------|-------------|-------------|-------------|-------------|
|   | 2110   | 2111               | 2113        | 2113        | 2114        | 2115        | 2116        |
| <b>Optional Settings - High Efficiency</b>  |  |                    |             |             |             |             |             |
| Salt Used - Per Regeneration                | 2.3 lbs                                      | 3.0 lbs            | 2.3 lbs     | 3.0 lbs     | 3.75 lbs    | 6.0 lbs     | 9.0 lbs     |
| Water Used - Regeneration                   | 22.7 gal                                     | 28.3 gal           | 22.6 gal    | 31.6 gal    | 39.5 gal    | 60.9 gal    | 102.2 gal   |
| Hardness Removal - Grains                   | 11,250                                       | 15,000             | 11,250      | 15,000      | 18,750      | 30,000      | 45,000      |
| <b>Factory Settings - Standard Capacity</b> |  |                    |             |             |             |             |             |
| Salt Used - Per Regeneration                | 4.5 lbs                                      | 6.0 lbs            | 4.5 lbs     | 6.0 lbs     | 7.5 lbs     | 12.0 lbs    | 18.0 lbs    |
| Water Used - Regeneration                   | 40.5 gal                                     | 48.6 gal           | 34.0 gal    | 43.4 gal    | 54.3 gal    | 87.1 gal    | 139.2 gal   |
| Hardness Removal - Grains                   | 18,750                                       | 25,000             | 18,750      | 25,000      | 31,250      | 50,000      | 75,000      |
| <b>Optional - High Capacity</b>             |  |                    |             |             |             |             |             |
| Salt Used - Per Regeneration                | 7.5 lbs                                      | 10.0 lbs           | 7.5 lbs     | 10.0 lbs    | 12.5 lbs    | 20.0 lbs    | 30.0 lbs    |
| Water Used - Regeneration                   | 56.1 gal                                     | 69.5 gal           | 49.6 gal    | 64.3 gal    | 80.37 gal   | 124.6 gal   | 196.2 gal   |
| Hardness Removal - Grains                   | 22,500                                       | 30,000             | 22,500      | 30,000      | 40,000      | 60,000      | 90,000      |
| Resin Quantity - Cubic Feet                 | 0.75 ft                                      | 1.0 ft             | 0.75 ft     | 1.0 ft      | 1.25 ft     | 2.0 ft      | 3.0 ft      |
| Tank Size                                   | 9x35   | 10x35              | 9x35        | 10x35       | 10x47       | 12x52       | 14x65       |
| Tank Jacket / Media Loaded                  | Yes  | Yes                | Yes         | Yes         | Yes         | No          | No          |
| Brine Tank / Cabinet Size (Inches)          | 16.5 x 19.3 x 43.3                           | 16.5 x 19.3 x 43.3 | 18.1 x 34.5 | 18.1 x 34.5 | 18.1 x 34.5 | 20.3 x 37.4 | 23.0 x 40.5 |
| Salt Storage Capacity                       | 175 lbs                                      | 175 lbs            | 240 lbs     | 240 lbs     | 240 lbs     | 350 lbs     | 420 lbs     |
| Flow Rate @ 15 psi Pressure Drop            | 11.6 gpm                                     | 12.0 gpm           | 10.4 gpm    | 11.0 gpm    | 12 gpm      | 12.2 gpm    | 12.6 gpm    |
| Flow Rate @ 25 psi Pressure Drop            | 15.6 gpm                                     | 16.0 gpm           | 14.3 gpm    | 15.0 gpm    | 15.5 gpm    | 16.2 gpm    | 16.6 gpm    |
| Back Wash Flow Rate                         | 2.0 gpm                                      | 2.4 gpm            | 1.5 gpm     | 2.0 gpm     | 2.4 gpm     | 3.5 gpm     | 5.0 gpm     |
| Shipping Weight                             | 93 lbs                                       | 110 lbs            | 105 lbs     | 122 lbs     | 154 lbs     | 172 lbs     | 244 lbs     |
| Regeneration Type                           | Co Current / Down Flow                       |                    |             |             |             |             |             |
| Plumbing Connections                        | Includes 3/4" 90° Elbows & 1" Straight NPT   |                    |             |             |             |             |             |
| Resin Type                                  | Aquafine 8% High Capacity Ion Exchange Resin |                    |             |             |             |             |             |
| Electrical Requirements                     | Input 120V 60 Hz - Output 12V 650mA          |                    |             |             |             |             |             |
| Water Temperature                           | Min 39 - Max. 100 degrees Fahrenheit         |                    |             |             |             |             |             |
| Water Pressure                              | Min. 20 - Max. 125 psi                       |                    |             |             |             |             |             |

# EconoFlo Series Water Softener

The economical and reliable EconoFlo Series Water Softener offers simple electronics for the same price as mechanical metered units. Offer your customers more for less. Manually index cycle position for easier, faster installation and service.

## Features:

- ▶ **Exclusive WaterGroup NSF Certified** electronic control valve with reliable piston, seal and spacer technology 
- ▶ **Manual index dial** for quick manual regeneration or cycle position selection
- ▶ **Simple electronics:** just set time of day, hardness and number of people
- ▶ **Control valve** also offers 48 hour memory back up, adjustable cycle times and optional regeneration modes (Meter Immediate, Meter Delayed, Meter Override, Calendar Clock)
- ▶ **System is WQA Tested** and Certified against CSA B483.1 
- ▶ **NSF Certified** Pressure Tank 
- ▶ **WQA Gold Seal** approved cation exchange resin 
- ▶ **Available in** traditional twin tank or compact cabinet design
- ▶ **Factory installed** one piece meter-in-bypass saves installation time and space
- ▶ **Quick connect fittings** on bypass, drain line, brine line and power cord for faster easier installations. Drain line o-ring eliminates need for Teflon.



Uses **50% Less Salt**  
**28% Less Water\***

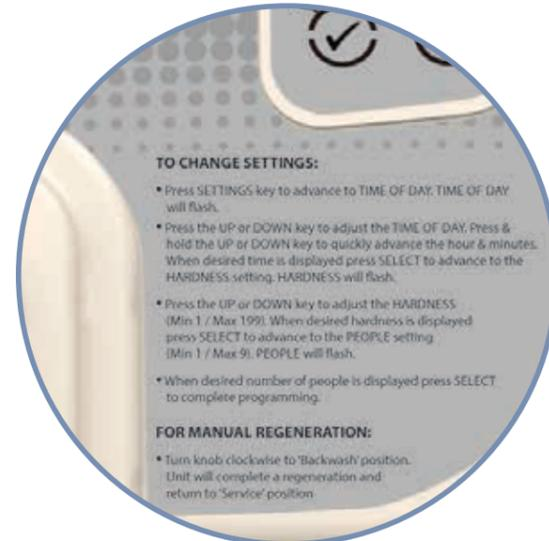

**Simpler than setting your alarm clock!**

### TO CHANGE SETTINGS:

- Press SETTINGS key to advance to TIME OF DAY. TIME OF DAY will flash.
- Press the UP or DOWN key to adjust the TIME OF DAY. Press & hold the UP or DOWN key to quickly advance the hour & minutes. When desired time is displayed press SELECT to advance to the HARDNESS setting. HARDNESS will flash.
- Press the UP or DOWN key to adjust the HARDNESS. (Min 1 / Max 199). When desired hardness is displayed press SELECT to advance to the PEOPLE setting. (Min 1 / Max 9). PEOPLE will flash.
- When desired number of people is displayed press SELECT to complete programming.

### FOR MANUAL REGENERATION:

- Turn knob clockwise to 'Backwash' position. Unit will complete a regeneration and return to 'Service' position.



5 Year Warranty Control Valve | 10 Year Warranty Pressure Tank



WQA Tested & Certified to NSF/ANSI 44 for effective reduction of hardness as verified and substantiated by test data.

\*Compared to conventional calendar clock models

| Model Number                   | Item Number | Capacity - Grains                            |                               |               | Flow Rate     |                | Mineral Tank Size (Inches) | Total Resin (cu. ft.) | Cabinet or Brine Tank Size Inches (WxDXH) | Salt Capacity (lbs) | Shipping Weight (lbs) |
|--------------------------------|-------------|--|-------------------------------|---------------|---------------|----------------|----------------------------|-----------------------|---|---------------------|-----------------------|
|                                |             | @ 10 lbs/cu ft                               | @ 6 lbs/cu ft Factory Setting | @ 3 lbs/cu ft | Service USGPM | Backwash USGPM |                            |                       |   |                     |                       |
| EFC20                          | 2117        | 19,875                                       | 16,500                        | 10,500        | 8             | 2              | 9X35                       | 0.75                  | 13.8 X 23.6 X 34.5                        | 225                 | 93                    |
| EFC30                          | 2118        | 26,500                                       | 22,000                        | 14,000        | 10            | 2.4            | 10X35                      | 1                     | 13.8 X 23.6 X 34.5                        | 225                 | 110                   |
| EFT20                          | 2119        | 19,875                                       | 16,500                        | 10,500        | 8             | 2              | 9X35                       | 0.75                  | 16.6X 16.7 X 61                           | 230                 | 93                    |
| EFT30                          | 2120        | 26,500                                       | 22,000                        | 14,000        | 10            | 2.4            | 10X35                      | 1                     | 16.6X 16.7 X 61                           | 230                 | 110                   |
| EFT40                          | 2121        | 33,125                                       | 27,500                        | 17,500        | 12            | 2.4            | 10X47                      | 1.25                  | 16.6X 16.7 X 61                           | 230                 | 141                   |
| EFT60                          | 2122        | 53,000                                       | 44,000                        | 28,000        | 13            | 3.5            | 12X52                      | 2                     | 18.9 X 18.9 X65.6                         | 270                 | 158                   |
| EFT90                          | 2123        | 79,500                                       | 66,000                        | 42,000        | 15            | 5              | 14X65                      | 3                     | 24.6 X 24.6 X 84                          | 700                 | 244                   |
| <b>Regeneration Type</b>       |             | Co current / Down Flow                       |                               |               |               |                |                            |                       |   |                     |                       |
| <b>Plumbing Connections</b>    |             | Includes 3/4" 90°Elbows & 1" Straight NPT    |                               |               |               |                |                            |                       |   |                     |                       |
| <b>Resin Type</b>              |             | Aquafine 8% High Capacity Ion Exchange Resin |                               |               |               |                |                            |                       |   |                     |                       |
| <b>Electrical Requirements</b> |             | Input 120V 60 Hz - Output 12V 650mA          |                               |               |               |                |                            |                       |   |                     |                       |
| <b>Water Temperature</b>       |             | Min 39 - Max. 100 degrees Fahrenheit         |                               |               |               |                |                            |                       |   |                     |                       |
| <b>Water Pressure</b>          |             | Min. 20 - Max. 125 psi                       |                               |               |               |                |                            |                       |   |                     |                       |

# Water Softeners

## EcoSmart Series Water Softener



**ECS-20**

#15010410

**ECS-24**

#15010411

**ECS-34/39**

#15010412 (ECS-34)  
#15010414 (ECS-39)

## Features:

- ➔ Engineered for ultimate efficiency on clean municipal water applications
- ➔ Compact design for small spaces
- ➔ Uses over 75% less salt & water than conventional water softeners
- ➔ EcoSmart™ Intelligent electronic control:
  - Simple intuitive electronics. No confusing codes or symbols!
  - Rotating performance information display!
  - Adjustable cycles for peak efficiency!
- ➔ High-efficiency fine mesh cation resin
- ➔ Quality injection & blow molded cabinet
- ➔ Push release hinged salt lid for easy salt refill
- ➔ Brine safety valve provides additional overflow protection
- ➔ ECS-34 model not only softens but also filters out bad tastes & odors caused by chlorine & organics
- ➔ Removes up to 10 ppm ferrous iron

## Eco-Friendly Efficiency

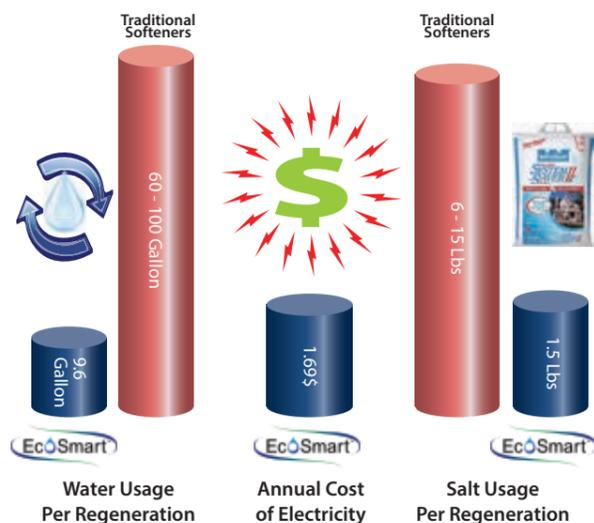

## Quality & Warranty

EcoSmart™ Water Softeners are built to last! All softeners are third party certified to meet the industry's most exacting standards and backed by one of the industries strongest warranties:

- Seven Year System Warranty
- Lifetime Pressure Tank & Cabinet Warranty



WQA Tested & Certified to NSF/ANSI 44 for effective reduction of hardness as verified and substantiated by test data.

## Compact Design

Super compact design is perfect for main floor laundry or where space is at a premium!



## Easy Installation

Complete installation kit including bypass, plumbing fittings & drain tubing. Quick connect fittings for simple installation. Includes easy to follow installation guide.



EcoSmart™ control valve & pressure tanks are NSF Certified

| Specifications                            | ECS-20  | ECS-24        | ECS-34        | ECS-39        |
|---|---|---------------|---------------|---------------|
|   | 15010410  | 15010411      | 15010412      | 15010414      |
| Maximum Hardness Removal                  | 19,500 grains   | 24,180 grains | 34,320 grains | 39,000 grains |
| <b>Factory Settings - High Efficiency</b> |   |               |               |               |
| Salt Used                                 | 1.5 lbs   | 2.1 lbs       | 2.4 lbs       | 3.0 lbs       |
| Water Used                                | 9.6 gal   | 11.7 gal      | 15.8 gal      | 17.9 gal      |
| System Capacity                           | 7,300 grains  | 10,200 grains | 11,700 grains | 15,400 grains |
| <b>High Capacity Settings</b>             |   |               |               |               |
| Salt Used                                 | 3.0 lbs   | 3.7 lbs       | 5.3 lbs       | 6.0 lbs       |
| Regeneration Water Used                   | 16.9 gal  | 21.4 gal      | 32.5 gal      | 34.6 gal      |
| System Capacity                           | 12,000 grains   | 16,800 grains | 19,200 grains | 25,000 grains |
| Coconut Activated Carbon                  | No  | No            | Yes           | No            |
| Integrated Meter in Bypass                | Yes   | Yes           | Yes           | Yes           |
| Plumbing Connections                      | 3/4" or 1"  | 3/4" or 1"    | 3/4" or 1"    | 3/4" or 1"    |
| Flow Rate @ 15 psi Pressure Drop          | 10.9 gpm  | 10.2 gpm      | 10.0 gpm      | 10.0 gpm      |
| Salt Storage Capacity                     | 80 lbs  | 120 lbs       | 170 lbs       | 170 lbs       |
| Shipping Weight                           | 58.5 lb   | 68.3 lb       | 84.3 lb       | 87.5 lb       |
| Regeneration Type                         | Co-current / Downflow   |               |               |               |
| Maximum Efficiency                        | 5,600 grains /lb salt   |               |               |               |
| Electrical Requirements                   | 120V 50/60 Hz   |               |               |               |
| Maximum Water Temperature                 | 120 degrees Fahrenheit  |               |               |               |
| Water Pressure                            | min. 20 - max. 120 psi  |               |               |               |
| Foot Print                                | 13" w x 18" d (ECS-20 26" h / ECS-24 35" h / ECS-34&39 43" h) |               |               |               |
| Plumbing Connections                      | Includes 3/4" 90° Elbows & 1" Straight NPT                    |               |               |               |

## Shower Softener

Just want soft water for your shower? This compact water-proof shower unit requires no electricity. The one-step manual regeneration is easy to operate. Small portable design makes it perfect for non-winterized cottages.



### Features:

- ➔ Easy installation
- ➔ No electricity required
- ➔ Waterproof slide cover
- ➔ One step regeneration process

| Item #   | Model           | Mineral Tank Size (IN) | Resin Cu Ft | Brine Tank / Cabinet Size Inches (WxDxH) | Ship Weight (Lbs) |
|----------|-----------------|------------------------|-------------|--|-------------------|
| 15180001 | SHOWER SOFTENER | 7 x 13                 | 0.22        | 8.7 x 14.2 x 19.2                        | 20                |



# Whole-House Automatic Water Filters

## Protect Your Plumbing From Bad Taste and Odor Caused by Chlorine and Other Chemicals.

### Remove Disinfectants From Your Water

Once water arrives safely at your home there is no further need for disinfectants. In fact they are undesirable!

- ➔ Taste and bad odor
- ➔ Dry skin
- ➔ Damage plumbing
- ➔ Can produce potentially harmful by-products

### Leaky Faucet or Toilet?

Chlorine is a strong oxidant that quickly destroys plastic & rubber seals & gaskets in appliances & plumbing causing leaks.

### Pin Hole Leaks in Pipes!

Chloramines are corrosive by nature and will eventually cause costly damage to plumbing – causing pitting & pin hole leaks.



## 185 Filters

| Specifications                   | WG185ACF75           | WG185ACF10 | WG185ACF15 | WG185ACF20 | WG185ACF30 |
|----------------------------------|----------------------|------------|------------|------------|------------|
|                                  | 2150                 | 2151       | 2152       | 2153       | 2220       |
| Normal Service Flow Rate         | 4.0 gpm              | 5.0 gpm    | 7.0 gpm    | 10 gpm     | 12.0 gpm   |
| Peak Service Flow Rate           | 5.0 gpm              | 7.0 gpm    | 10.0 gpm   | 12.0 gpm   | 15.0 gpm   |
| Backwash Flow Rate               | 3.5 gpm              | 4.0 gpm    | 5.0 gpm    | 7.0 gpm    | 10.0 gpm   |
| Filter Media Volume - Cubic Feet | 0.75 ft <sup>3</sup> | 1.0 ft     | 1.5 ft     | 2.0 ft     | 3.0 ft     |
| Filter Tank Size                 | 8x44                 | 9x48       | 10x54      | 12x52      | 14x65      |
| Tank Jacket / Media Loaded       | Yes                  | Yes        | Yes        | No         | No         |
| Shipping Weight                  | 50 lbs               | 60 lbs     | 78 lbs     | 95 lbs     | 138 lbs    |

| Specifications                   | WG185CLAF75               | WG185CLAF10 | WG185CLAF15 | WG185CLAF20 |
|----------------------------------|---------------------------|-------------|-------------|-------------|
|                                  | 2221                      | 2222        | 2223        | 2224        |
| Recommended Flow Rates           | 4.0 gpm                   | 5.0 gpm     | 7.5 gpm     | 10.0 gpm    |
| Backwash Flow Rate               | 3.5 gpm                   | 4.0 gpm     | 5.0 gpm     | 7.0 gpm     |
| Filter Media Volume - Cubic Feet | 1.5 ft <sup>3</sup>       | 2.0 ft      | 3.0 ft      | 4.0 ft      |
| Filter Tank Size (qty 2)         | 8x44                      | 9x48        | 10x54       | 12x52       |
| Tank Jacket                      | Yes                       | Yes         | Yes         | No          |
| Shipping Weight                  | 100 lbs                   | 120 lbs     | 155 lbs     | 190 lbs     |
| Carbon Type                      | Canature Catalytic Carbon |             |             |             |

| Specifications                   | WG185MMF75           | WG185MMF10   | WG185MMF15   | WG185MMF20   | WG185MMF30   |
|----------------------------------|----------------------|--------------|--------------|--------------|--------------|
|                                  | 2166                 | 2167         | 2168         | 2169         | 2225         |
| Normal Service Flow Rate         | 4.0 gpm              | 5.0 gpm      | 7.0 gpm      | 10.0 gpm     | 12.0 gpm     |
| Peak Service Flow Rate           | 5.0 gpm              | 7.0 gpm      | 10.0 gpm     | 12.0 gpm     | 15.0 gpm     |
| Micron Rating                    | 15-20 micron         | 15-20 micron | 15-20 micron | 15-20 micron | 15-20 micron |
| Backwash Flow Rate               | 4.0 gpm              | 5.0 gpm      | 7.0 gpm      | 10.0 gpm     | 14.0 gpm     |
| Filter Media Volume - Cubic Feet | 0.75 ft <sup>3</sup> | 1.0 ft       | 1.5 ft       | 2.0 ft       | 3.0 ft       |
| Filter Tank Size                 | 8x44                 | 9x48         | 10x54        | 12x52        | 14x65        |
| Tank Jacket / Media Loaded       | Yes                  | Yes          | Yes          | No           | No           |
| Shipping Weight                  | 79 lbs               | 118 lbs      | 144 lbs      | 198 lbs      | 342 lbs      |

| Specifications                   | WG185ULTRAMF75       | WG185ULTRAMF10 | WG185ULTRAMF15 | WG185ULTRAMF20 |
|----------------------------------|----------------------|----------------|----------------|----------------|
|                                  | 2170                 | 2171           | 2172           | 2173           |
| Normal Service Flow Rate         | 4.0 gpm              | 5.0 gpm        | 8.0 gpm        | 10.0 gpm       |
| Peak Service Flow Rate           | 7.0 gpm              | 8.0 gpm        | 10.0 gpm       | 12 gpm         |
| Micron Rating                    | 3-5 micron           | 3-5 micron     | 3-5 micron     | 3-5 micron     |
| Backwash Flow Rate               | 5.0 gpm              | 7.0 gpm        | 10.0 gpm       | 14.0 gpm       |
| Filter Media Volume - Cubic Feet | 0.75 ft <sup>3</sup> | 1.0 ft         | 1.5 ft         | 2.0 ft         |
| Filter Tank Size                 | 8x44                 | 9x48           | 10x54          | 12x52          |
| Tank Jacket                      | Yes                  | Yes            | Yes            | No             |
| Shipping Weight                  | 90 lbs               | 135 lbs        | 205 lbs        | 255 lbs        |

| Specifications                   | WG185NNF75           | WG185NNF10 | WG185NNF15 | WG185NNF20 | WG185NNF30 | WG185NNF10CALC | WG185NNF15CALC |
|----------------------------------|----------------------|------------|------------|------------|------------|----------------|----------------|
|                                  | 2174                 | 2175       | 2176       | 2177       | 2226       | 2227           | 2228           |
| Normal Service Flow Rate         | 2.0 gpm              | 3.0 gpm    | 5.0 gpm    | 6.0 gpm    | 7.0 gpm    | 3.0 gpm        | 5.0 gpm        |
| Peak Service Flow Rate           | 3.5 gpm              | 5.0 gpm    | 8.0 gpm    | 10.0 gpm   | 12.0 gpm   | 5.0 gpm        | 8.0 gpm        |
| Backwash Flow Rate               | 3.5 gpm              | 4.0 gpm    | 5.0 gpm    | 7.0 gpm    | 10.0 gpm   | 4.0 gpm        | 5.0 gpm        |
| Filter Media Volume - Cubic Feet | 0.75 ft <sup>3</sup> | 1.0 ft     | 1.5 ft     | 2.0 ft     | 3.0 ft     | 1.0 ft         | 1.5 ft         |
| Filter Tank Size                 | 8x44                 | 9x48       | 10x54      | 12x52      | 14x65      | 9x48           | 10x54          |
| Tank Jacket / Media Loaded       | Yes                  | Yes        | Yes        | No         | No         | Yes            | Yes            |
| Shipping Weight                  | 93 lbs               | 120 lbs    | 164 lbs    | 207 lbs    | 330 lbs    | 120 lbs        | 164 lbs        |

For low pH applications

| Specifications  | WG185ISF75           | WG185ISF10 | WG185ISF15               | WG185ISF20 | WG185ISF30 |
|---|----------------------|------------|--------------------------|------------|------------|
|   | 2162                 | 2163       | 2164                     | 2165       | 2197       |
| Normal Service Flow Rate  | 3.0 gpm              | 3.0 gpm    | 4.0 gpm                  | 5.0 gpm    | 6.0 gpm    |
| Peak Service Flow Rate  | 4.0 gpm              | 5.0 gpm    | 8.0 gpm                  | 10.0 gpm   | 12.0 gpm   |
| Backwash Flow Rate  | 3.5 gpm              | 4.0 gpm    | 5.0 gpm                  | 7.0 gpm    | 10.0 gpm   |
| Compensated Iron Removal Capacity                                   | 4,500 ppm            | 6,000 ppm  | 9,500 ppm                | 12,000 ppm | 18,000 ppm |
| KMnO4 per Regen   | 4 oz                 | 4 oz       | 4 oz                     | 8 oz       | 8 oz       |
| Filter Media Volume - Cubic Feet                                    | 0.75 ft <sup>3</sup> | 1.0 ft     | 1.5 ft                   | 2.0 ft     | 3.0 ft     |
| Filter Tank Size  | 8x44                 | 9x48       | 10x54                    | 12x52      | 14x65      |
| Tank Jacket / Media Loaded  | Yes                  | Yes        | Yes                      | No         | No         |
| Shipping Weight   | 113 lbs              | 129 lbs    | 179 lbs                  | 233 lbs    | 352 lbs    |
| Maximum Combination of Iron X 1, Manganese X 2, H <sub>2</sub> S X3 | 10.0 ppm             |            | Maximum Hydrogen Sulfide |            | 3.0 ppm    |
| Maximum Iron (Ferrous)  | 7.0 ppm              |            | Maximum Manganese        |            | 5.0 ppm    |
| Bacterial Iron  | 0.0 ppm              |            | Minimum pH               |            | 7.0        |

| All Filters             |  |
|-------------------------|--|
| Plumbing Connections    | Includes 3/4" 90° Elbows & 1" Straight NPT |
| Electrical Requirements | Input 120V 60 Hz - Output 12V 650mA        |
| Water Temperature       | Min 39 - Max. 100 degrees Fahrenheit       |
| Water Pressure          | Min. 20 - Max. 125 psi                     |

# WaterGroup 185 Series Water Filters

Problem water is no problem with our full line of WaterGroup 185 Water Filters. Eliminate iron, sediment, bad tastes, stains and odors, as well as, color caused by organics. The high-efficiency control valve monitors water usage and flushes the system automatically, readying it for operation again.

- ➔ **Taste & Odor Filters (ACF):** Chlorine and organic matter can make your water smell and taste terrible. The WaterGroup 185 Taste & Odor filter uses high-quality granular activated carbon to absorb the problem-causing substances.
- ➔ **Chloramine Removal Filters (CLAF):** Chloramines are now commonly used to disinfect municipal water supplies causing taste & odor problems. To remove chloramines a special catalytically enhanced carbon is required.
- ➔ **Multi Media Filters (MM):** Cloudy water means you likely have suspended silt or sediment. Restore your water to crystal clear as the WaterGroup 185 Multi-Media filter traps particulate matter as small as 20 microns.
- ➔ **Nexsand Turbidity Filters (Ultra MF):** Remove suspended solids, Ferric Hydroxide (Red Water Iron) or Sediment from your well or water system down to 5 Microns. Nexsand has proven extremely effective and will double the service flow of Multi Media or Sand Filters.
- ➔ **Neutralizing Filters (NNF):** The WaterGroup 185 Neutralizing filters raise the pH of acidic water to neutralize corrosiveness protecting fixtures, pipes and appliances.
- ➔ **Iron & Sulfur Filters (ISF):** Water comes in contact with manganese greensand causing oxidization into solids which can be trapped in the filter bed



Chloramine (CLAF) Units use Two Tank System for effective reduction of chloramines

## Features:

- ➔ Exclusive NSF Certified control valve with reliable electronic sensors, adjustable cycle time and proven piston, seal & spacer design
- ➔ NSF Certified fibreglass pressure tank
- ➔ Tank jackets reduce condensation.
- ➔ User-friendly backlit LCD display
- ➔ Simple set up and programming with no confusing codes or symbols to remember
- ➔ Automatic Vacation Mode prevents media cementing
- ➔ "No Touch" LCD information display rotates key info like last regeneration date, current flow rate & peak flow rate
- ➔ Unique, compact one piece bypass with integrated turbine meter
- ➔ Time saving quick connect fittings on bypass, drain & brine line. Even the power cord has quick connects
- ➔ Drain line o-ring. No need for Teflon
- ➔ Audible Cycle Advance Alarm
- ➔ 48 hour self charging battery back-up
- ➔ Meter Immediate, Meter Delayed, and Meter with Day Over ride
- ➔ Includes hose clamp and 10' of drain tubing

# WaterGroup 465 BIF Chemical Free iron Filter



## Features:

- ➔ Natural oxidation removes iron, manganese and sulphur without chemicals, air pumps or a venturi
- ➔ Low maintenance two tank system
- ➔ Regenerates less frequently than traditional iron filters using up to 50% less water than manganese greensand filters
- ➔ NSF Certified electronic control valve
- ➔ NSF Certified fibreglass pressure tanks
- ➔ Meter Immediate, Meter Delayed, Meter with Day Override, Vacation and Calendar Clock mode
- ➔ Adjustable cycle times
- ➔ Unique bypass with an integrated space saving turbine meter and sample port on the inlet. One-piece design avoids meter jamming
- ➔ Time saving quick connect fittings on bypass
- ➔ Quick connect drain line o-ring eliminates need for Teflon
- ➔ Power cord even has quick connect for easy valve spin on
- ➔ Hose clamp and 10' of drain tubing included



| Item # | Model        | Media Cu Ft | Flow Rate USGPM |      |          | Mineral Tank Size | Air Contact Tank | Pipe Size Inches | Ship Weight Lbs |
|--------|--------------|-------------|-----------------|------|----------|-------------------|------------------|------------------|-----------------|
|        |              |             | Service         | Peak | Backwash |                   |                  |                  |                 |
| 2198   | WG465BIF75   | 0.75        | 2.0             | 5.0  | 3.5      | 8 x 44            | 8 x 44           | 3/4"             | 132             |
| 2199   | WG465BIF10   | 1.0         | 3.0             | 6.0  | 4.0      | 10 x 44           | 8 x 44           | 3/4"             | 150             |
| 2200   | WG465BIF15   | 1.5         | 4.0             | 10.0 | 5.0      | 10 x 54           | 10 x 54          | 3/4"             | 188             |
| 2205   | WG465BIFMN75 | 0.75        | 2.0             | 5.0  | 3.5      | 8 x 44            | 8 x 44           | 3/4"             | 132             |
| 2206   | WG465BIFMN10 | 1.0         | 3.0             | 6.0  | 4.0      | 10 x 44           | 8 x 44           | 3/4"             | 150             |
| 2207   | WG465BIFMN15 | 1.5         | 4.0             | 10.0 | 5.0      | 10 x 54           | 10 x 54          | 3/4"             | 188             |

\*MN Models for low pH and/or high manganese applications

# 95 BIF Series Two Tank Iron Filter System



## Remove Stubborn Iron, Manganese & Hydrogen Sulfide Without Chemicals

Incoming raw water passes through a compressed pocket of air contained in the first tank. The air precipitates the iron into solid form and is removed when it passes through the filters media bed contained in the second tank. The media acts as a catalyst in the reaction between iron and oxygen that also causes the iron to precipitate into a solid.

As more water passes through the unit the air becomes depleted and the media becomes overloaded with the iron. Periodic automatic regeneration replenishes the supply of air and cleans the media of filtered iron. The media is not consumed in the iron removal process and therefore is much more economical than many other iron removal processes.

### Features:

- ➔ Natural oxidation removes iron, manganese and H<sub>2</sub>S without chemicals, air pumps or a venturi
- ➔ System regenerates less frequently using up to 50% less water than manganese greensand filters
- ➔ Exclusive Canature 95 Series control valve with reliable electronic sensors, piston, seals and spacer technology
- ➔ Water proof power head enclosure
- ➔ High flow rates for large residential & commercial applications
- ➔ Time saving quick connects for easy installation
- ➔ Easy access sample ports with quick connect clips

| Specifications  | 95BIF-100  | 95BIF-150   | 95BIF-200   | 95BIF-300   | 95BIF-400   | 95BIF-500   |
|---|--|-------------|-------------|-------------|-------------|-------------|
|   | 2208   | 2209        | 2210        | 2211        | 2212        | 2213        |
| *MN Models for low pH 6.0 - 6.9 & Manganese up to 1.0 ppm | 95BIFMN-100  | 95BIFMN-150 | 95BIFMN-200 | 95BIFMN-300 | 95BIFMN-400 | 95BIFMN-500 |
|   | 2214   | 2215        | 2216        | 2217        | 2218        | 2219        |
| Typical Service Flow Rate                                 | 3.0 gpm  | 4.0 gpm     | 5.0 gpm     | 6.0 gpm     | 7.0 gpm     | 9.0 gpm     |
| Peak Flow Rate  | 6.0 gpm  | 10.0 gpm    | 12.0 gpm    | 14.0 gpm    | 16.0 gpm    | 18.0 gpm    |
| Backwash Flow Rate  | 5.0 gpm  | 5.0 gpm     | 7.0 gpm     | 10.0 gpm    | 14.0 gpm    | 21.0 gpm    |
| Filter Media Volume - Cubic Feet                          | 1.0 ft   | 1.5 ft      | 2.0ft       | 3.0 ft      | 4.0 ft      | 5.0 ft      |
| Filter Tank Size  | 10x44  | 10x54       | 12x52       | 14x65       | 16x65       | 18x65       |
| Air Contact Tank Size                                     | 8x44   | 10x54       | 12x52       | 14x65       | 14x65       | 14x65       |
| Shipping Weight   | 150 lbs  | 188 lbs     | 248 lbs     | 368 lbs     | 443 lbs     | 518 lbs     |
| Media Loaded  | Yes  | Yes         | No          | No          | No          | No          |
| Maximum Iron  | 30.0 ppm   |             |             |             |             |             |
| Hydrogen Sulfide  | 5.0 ppm  |             |             |             |             |             |
| Mangansese  | BIF Model 0.0 ppm / BIFMN Models up to 1.0 ppm     |             |             |             |             |             |
| Iron Bacteria Removal                                     | Yes  |             |             |             |             |             |
| pH  | BIF Models pH 7.0 - 8.5 / BIFMN Models pH 6.0 -6.9 |             |             |             |             |             |
| Plumbing Connections                                      | 3/4", 1", 1 1/4", 1 1/2"                           |             |             |             |             |             |
| Electrical Requirements                                   | Input 120V 60 Hz - Output 12V 650mA                |             |             |             |             |             |
| Water Temperature   | Min 39 - Max. 100 degrees Fahrenheit               |             |             |             |             |             |
| Water Pressure  | Min. 20 - Max. 125 psi                             |             |             |             |             |             |

# AIO Chem Free Iron Filter

The AIO Chemical Free Iron filter is intended to be an effective and economical way to remove iron from water without the use of messy and dangerous chemicals or expensive pumps or an external venturi. The AIO valve uses a patented construction to create an air bubble at the upper portion of the tank to oxidize any ferrous iron prior to being filtered by the media. It can also used to remove low concentrations of dissolved hydrogen sulfide and manganese from water.

## How does the AIO (Air Induction Oxidization) filter work?

This filter works by adding oxygen to the incoming water by passing it through a bubble of compressed air. The water is then passed through a special filter bed

The special media not only increases the pH of the water to enhance iron removal but also acts as a physical barrier to trap iron precipitate.

As more water passes through this iron filter, the oxygen in the unit is used up, and the media gets loaded with iron. The regeneration process then begins in order to replenish the supply of oxygen, and to backwash the precipitated iron trapped in the media bed. The iron removal efficiency will be more effective with high pH water.

The filter is fitted with an inlet check valve to prevent any air from flowing backwards out of the filter tank.

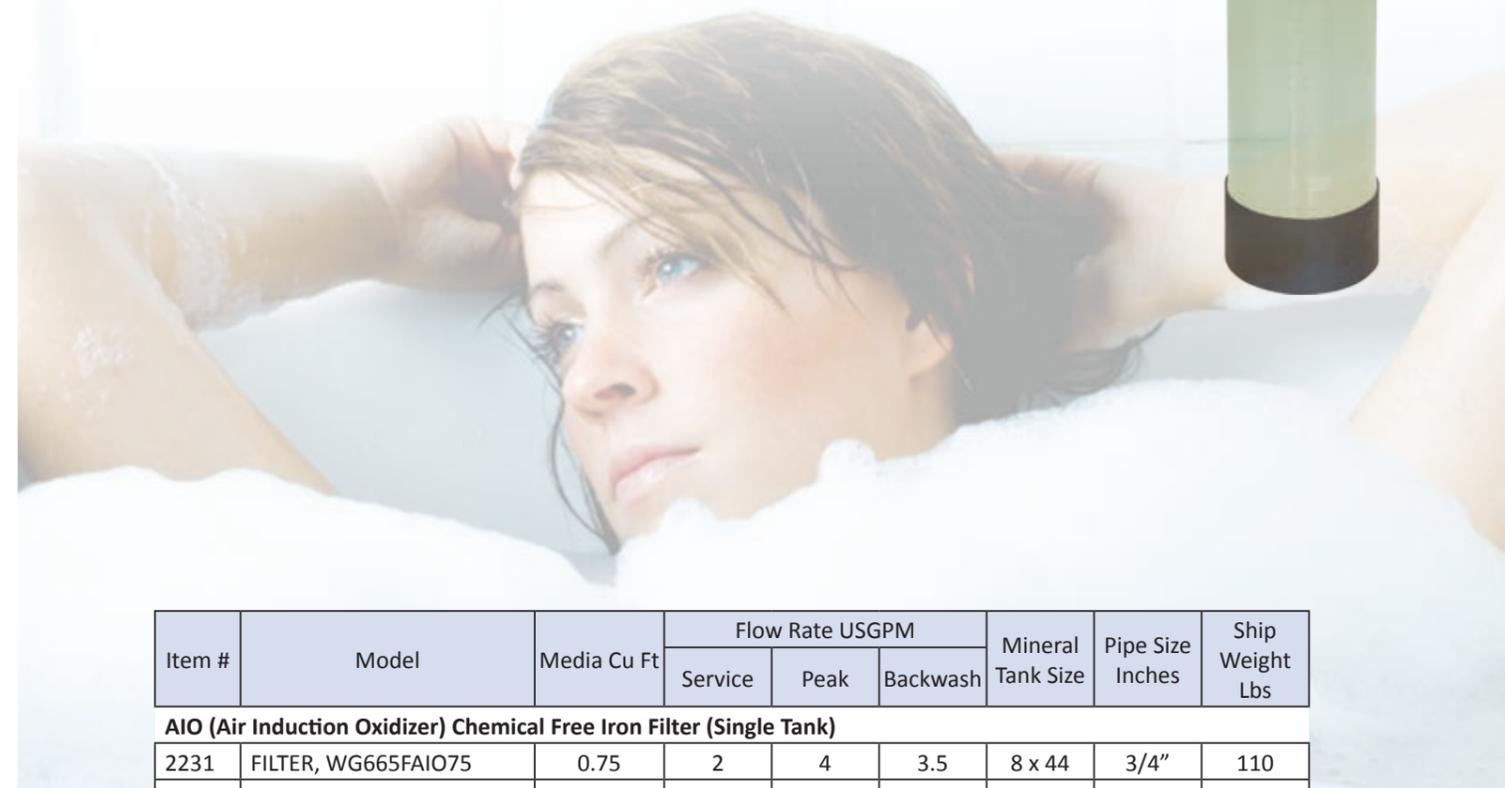

| Item #  | Model                | Media Cu Ft | Flow Rate USGPM |      |          | Mineral Tank Size | Pipe Size Inches | Ship Weight Lbs |
|---|----------------------|-------------|-----------------|------|----------|-------------------|------------------|-----------------|
|   |                      |             | Service         | Peak | Backwash |                   |                  |                 |
| <b>AIO (Air Induction Oxidizer) Chemical Free Iron Filter (Single Tank)</b> |                      |             |                 |      |          |                   |                  |                 |
| 2231  | FILTER, WG665FAIO75  | 0.75        | 2               | 4    | 3.5      | 8 x 44            | 3/4"             | 110             |
| 2232  | FILTER, WG665FAIO10  | 1.0         | 3               | 6    | 4        | 9 x 48            | 3/4"             | 145             |
| 2233  | FILTER, WG665FAIO15  | 1.5         | 4               | 10   | 5        | 10 x 54           | 3/4"             | 250             |
| 2235  | FILTER, WG665FAIO75M | 0.75        | 2               | 4    | 3.5      | 8 x 44            | 3/4"             | 110             |
| 2236  | FILTER, WG665FAIO10M | 1.0         | 3               | 6    | 4        | 9 x 48            | 3/4"             | 145             |
| 2237  | FILTER, WG665FAIO15M | 1.5         | 4               | 10   | 5        | 10 x 54           | 3/4"             | 250             |

# Hydrogen Sulfide Reduction AIO Filter

## Does Your Water Stink?

Hydrogen sulfide (H<sub>2</sub>S) is a nuisance. It adds an objectionable sulfur-like taste and "rotten egg" odor to drinking water. Left untreated, it can also lead to corrosion in drainage pipes and concrete sewers.

### Features:

- ➔ Combines aeration with catalytic carbon technology to effectively reduce sulfur from water.
- ➔ No more bad taste or odor.
- ➔ No Chemicals to buy, mix or add
- ➔ No weekly water tests to perform
- ➔ Simple, Fully Automatic regeneration with Air



# WG NRV (Non-Regenerating Valve) Whole House Carbon Filter

## Economical Reduction of Chlorine, Chloramines and other bad taste & Odors.

### Features:

- ➔ Economical whole-house carbon filtration solution for reducing chlorine (TO models), chloramines (TOK models) and other bad tastes and odors
- ➔ Factory installed one-piece bypass with incorporated meter
- ➔ Time saving quick connect fittings (90° 3/4" NPT Elbows and 1" Straight NPT) included for faster, easier installation. Optional quick connect SharkBite® fittings also available.
- ➔ Five year warranty on Distribution Head
- ➔ Ten Year Warranty on NSF Certified tank



*Economical non-back-washing distribution head with convenient quick connect fittings*



| Item #  | Model                | Cat Carbon Cu Ft | Flow Rate USGPM |      |          | Mineral Tank Size | Pipe Size Inches | Ship Weight Lbs |
|---|----------------------|------------------|-----------------|------|----------|-------------------|------------------|-----------------|
|   |                      |                  | Service         | Peak | Backwash |                   |                  |                 |
| <b>AIO (Air Induction Oxidizer) Filter For Hydrogen Sulfide Reduction (Single Tank)</b> |                      |                  |                 |      |          |                   |                  |                 |
| 2238  | FILTER, WG665FAIOC75 | 0.75             | 2               | 4    | 3.5      | 8 x 44            | 3/4"             | 110             |
| 2239  | FILTER, WG665FAIOC10 | 1.0              | 3               | 6    | 4        | 9 x 48            | 3/4"             | 145             |
| 2240  | FILTER, WG665FAIOC15 | 1.5              | 4               | 10   | 5        | 10 x 54           | 3/4"             | 250             |

| Specifications                   | NRV TO-100   | NRV TO-150     | NRV TOK-100    | NRV TOK-150    |
|----------------------------------|--|----------------|----------------|----------------|
|                                  | 15054073   | 15054074       | 15054075       | 15054076       |
| <b>Service Flow Rates</b>        |  |                |                |                |
| Normal                           | 5.0 gpm  | 7.0 gpm        | 5.0 gpm        | 7.0 gpm        |
| Peak                             | 7.0 gpm  | 10.0 gpm       | 7.0 gpm        | 10.0 gpm       |
| Filter Media Volume - Cubic Feet | 1.0 ft   | 1.5 ft         | 1.0 ft         | 1.5 ft         |
| Filter Tank Size                 | 9x48   | 10x54          | 9x48           | 10x54          |
| Media Type                       | Coconut Carbon   | Coconut Carbon | Coconut Carbon | Coconut Carbon |
| Media Loaded                     | Yes  | Yes            | Yes            | Yes            |
| KDF Protector                    | No   | No             | Yes            | Yes            |
| Tank Jacket                      | No   | No             | No             | No             |
| Shipping Weight                  | 60 lbs   | 78 lbs         | 60 lbs         | 78 lbs         |
| Plumbing Connections             | Includes 3/4" 90° Elbows & 1" Straight NPT. Bypass Included. |                |                |                |
| Electrical Requirements          | None   |                |                |                |
| Water Temperature                | Min 39 - Max. 100 degrees Fahrenheit                         |                |                |                |
| Water Pressure                   | Max. 125 psi   |                |                |                |

# Specialty Systems

## Soften & Filter Problems From Your Water

Many ground water supplies often have multiple problems that are not only an issue from an aesthetic standpoint but in terms of cost when pipes become clogged, fixtures stained and laundry discolored.

Combination units provide one solution for multiple problems saving you space and money

### WaterGroup 185 Series Specialty Combination Systems

WaterGroup offers a variety of specialty systems to fix a variety of water problems commonly found in combination in one water supply.

#### Types of Specialty Systems:

##### SIMTAN Series

Softener, Iron, Manganese & Tannin Removal

##### ST Series

Softener, Tannin and Color Combination Removal

##### IronGuard SIM Series

Softener, Iron and Manganese Combination Removal

##### TAN Series

Uses anion exchange resin to remove color caused by organic decay

##### HTO Series

Softener, Taste and Odor Removal

##### HEDP Series

Dual Pass Softener for High Hardness (> 75 gpg) Applications

##### NeutraSoft Series

Softens and adjusts low pH water



SIMTAN Series



SIM /ST Series



7 Year Warranty Control Valve



Lifetime Warranty Pressure tank



Easy Feeder plus 64 oz bottle of Res Care. Included with iron removal systems

#### SIMTAN Series Specifications

| Specifications                          | WG185SIMTAN10  | WG185SIMTAN15 | WG185SIMTAN20 | WG185SIMTAN30 |
|---|--|---------------|---------------|---------------|
| Purolite 850 Models*                    | 2180   | 2181          | 2182          | 2183          |
| Purolite 860 Models*                    | 2184   | 2185          | 2186          | 2187          |
| <b>Factory Settings - High Capacity</b> |  |               |               |               |
| Salt Used - Per Regeneration            | 12.0 lbs   | 18.0 lbs      | 24.0 lbs      | 36.0 lbs      |
| Water Used - Regeneration               | 64.3 gal   | 90.3 gal      | 124.6 gal     | 196.2 gal     |
| Hardness Removal - Grains               | 30,000   | 45,000        | 60,000        | 90,000        |
| Tannins Removal                         | 2000 ppm   | 3000 ppm      | 4000 ppm      | 6000 ppm      |
| Tank #1 Resin Quantity - Cubic Feet     | 1.0 ft   | 1.5 ft        | 2.0 ft        | 3.0 ft        |
| Tank #2 Resin Quantity - Cubic Feet     | 1.0 ft   | 1.5 ft        | 2.0 ft        | 3.0 ft        |
| Tank Size                               | 9x48   | 10x54         | 12x52         | 14x65         |
| Tank Jacket / Media Loaded              | Yes  | Yes           | No            | No            |
| Brine Tank / Cabinet Size (Inches)      | 18.1 x 34.5  | 20.3 x 37.4   | 20.3 x 37.4   | 23.0 x 40.5   |
| Salt Storage Capacity                   | 240 lbs  | 350 lbs       | 350 lbs       | 420 lbs       |
| Recommended Service Flow Rate           | 3.0 gpm  | 4.5 gpm       | 6.0 gpm       | 9.0 gpm       |
| Flow Rate @ 15 psi Pressure Drop        | 7.3 gpm  | 7.5 gpm       | 8.3 gpm       | 9.3 gpm       |
| Flow Rate @ 25 psi Pressure Drop        | 10.0 gpm   | 10.1 gpm      | 11.1 gpm      | 11.4 gpm      |
| Back Wash Flow Rate                     | 2.0 gpm  | 2.4 gpm       | 3.5 gpm       | 5.0 gpm       |
| Shipping Weight                         | 125 lbs  | 158 lbs       | 161 lbs       | 247 lbs       |
| Regeneration Type                       | Co-Current / Down Flow                               |               |               |               |
| Maximum Hardness                        | 75 Grains Per Gallon                                 |               |               |               |
| Maximum Tannins                         | 3.0 ppm (Contact Customer Service for higher levels) |               |               |               |
| Maximum Iron (Ferrous)                  | 10.0 ppm   |               |               |               |
| Maximum Manganese                       | 5.0 ppm  |               |               |               |
| Resin Type                              | Aquafine Cation / Anion Exchange Resin               |               |               |               |

#### ST Series Specifications

| Specifications                          | WG185ST45-860                          | WG185ST60-860 | WG185ST90-860 |
|---|--|---------------|---------------|
|   | 2179                                   | 2141          | 2142          |
| <b>Factory Settings - High Capacity</b> |  |               |               |
| Salt Used - Per Regeneration            | 18.0 lbs                               | 24.0 lbs      | 36.0 lbs      |
| Water Used - Regeneration               | 74.4 gal                               | 101.4 gal     | 166 gal       |
| Resin Quantity - Cubic Feet             | 1.5 ft                                 | 2.0 ft        | 3.0 ft        |
| Tank Size                               | 10x54                                  | 12x52         | 14x65         |
| Tank Jacket / Media Loaded              | Yes                                    | No            | No            |
| Brine Tank / Cabinet Size (Inches)      | 20.3 x 37.4                            | 20.3 x 37.4   | 23.0 x 40.5   |
| Salt Storage Capacity                   | 350 lbs                                | 350 lbs       | 420 lbs       |
| Recommended Service Flow Rate           | 3.0 gpm                                | 3.0 gpm       | 6.0 gpm       |
| Flow Rate @ 15 psi Pressure Drop        | 11.2 gpm                               | 12.2 gpm      | 12.6 gpm      |
| Flow Rate @ 25 psi Pressure Drop        | 15.1 gpm                               | 16.2 gpm      | 16.6 gpm      |
| Back Wash Flow Rate                     | 2.4 gpm                                | 3.5 gpm       | 5.0 gpm       |
| Shipping Weight                         | 158 lbs                                | 175 lbs       | 247 lbs       |
| Regeneration Type                       | Co-Current / Down Flow                 |               |               |
| Maximum Hardness                        | 20 Grains Per Gallon                   |               |               |
| Maximum Tannins                         | 1.0 ppm                                |               |               |
| Resin Type                              | Aquafine Cation / Anion Exchange Resin |               |               |

#### All Specialty Systems

|                         |  |
|-------------------------|--|
| Plumbing Connections    | Includes 3/4" 90° Elbows & 1" Straight NPT |
| Electrical Requirements | Input 120V 60 Hz - Output 12V 650mA        |
| Water Temperature       | Min 39 - Max. 100 degrees Fahrenheit       |
| Water Pressure          | Min. 20 - Max. 125 psi                     |

# 185 IronGuard SIM Series



## Enjoy Iron-Free Soft Water

Combining proven water softener capabilities with the ability to remove clear and red water iron, the Iron Guard SIM system provides an effective and economical solution to hard and iron contaminated water. In addition, Iron Guard Plus, is specially designed for application in low pH (acidic) water. Hard water contains dissolved calcium and magnesium which build up inside your water heater, plumbing fixtures and appliances. The minerals also react with soap to form a scum which appears as bathtub ring, greys your laundry and leaves your hair dull and your skin itchy. Iron water leaves yellow, orange or brown stains on your laundry, sinks, tubs and toilets.

Iron Guard contains a bed of fine mesh ion exchange resin beads. As water passes through the bed, calcium and magnesium, the hardness minerals, and any clear or red water iron are removed and held by the resin. The Iron Guard Plus bed contains calcium carbonate in addition to the fine mesh ion exchange resin. This media combines to raise low pH water to enable the resin to remove hardness and red water iron.

Eventually, the resin beads become saturated and must be regenerated. A brine solution is drawn into the bed to drive out the accumulated minerals. This process is called ion exchange. After the minerals and brine are rinsed out with fresh water, the regenerated resin is ready to soften your water again. The demand regeneration control valve includes a metering system which monitors your soft water use, regenerating only when necessary based on your water usage. Consequently, you save salt, water and money.

| Specifications                                 | WG185SIM30   | WG185SIM45  | WG185SIM60  | WG185SIM90  | WG185SIM30+ |
|--|--|-------------|-------------|-------------|-------------|
|  | 2137   | 2138        | 2139        | 2178        | 2140        |
| <b>Factory Settings - Iron &amp; Manganese</b> |  |             |             |             |             |
| Salt Used - Per Regeneration                   | 12.0 lbs   | 18.0 lbs    | 24.0 lbs    | 36.0 lbs    | 36.0 lbs    |
| Water Used - Regeneration                      | 52.2 gal   | 74.4 gal    | 101.4 gal   | 166 gal     | 166 gal     |
| Hardness Removal - Grains                      | 30,000   | 45,000      | 60,000      | 90,000      | 90,000      |
| Resin Quantity - Cubic Feet                    | 1.0 ft   | 1.5 ft      | 2.0 ft      | 3.0 ft      | 3.0 ft      |
| Tank Size                                      | 9x48   | 10x54       | 12x52       | 14x65       | 14x65       |
| Tank Jacket / Media Loaded                     | Yes  | Yes         | No          | No          | No          |
| Brine Tank / Cabinet Size (Inches)             | 18.1 x 34.5  | 20.3 x 37.4 | 20.3 x 37.4 | 23.0 x 40.5 | 23.0 x 40.5 |
| Salt Storage Capacity                          | 240 lbs  | 350 lbs     | 350 lbs     | 420 lbs     | 420 lbs     |
| Flow Rate @ 15 psi Pressure Drop               | 11.0 gpm   | 11.2 gpm    | 12.2 gpm    | 12.6 gpm    | 12.6 gpm    |
| Flow Rate @ 25 psi Pressure Drop               | 15.0 gpm   | 15.1 gpm    | 16.2 gpm    | 16.6 gpm    | 16.6 gpm    |
| Back Wash Flow Rate                            | 2.1 gpm  | 2.4 gpm     | 3.5 gpm     | 5.0 gpm     | 5.0 gpm     |
| Shipping Weight                                | 125 lbs  | 158 lbs     | 175 lbs     | 247 lbs     | 247 lbs     |
| Regeneration Type                              | Co-Current / Down Flow                             |             |             |             |             |
| Maximum Hardness                               | 75 Grains Per Gallon                               |             |             |             |             |
| Maximum Iron (Ferrous)                         | 10 ppm   |             |             |             |             |
| Maximum Manganese                              | 5 ppm  |             |             |             |             |
| Resin Type                                     | Aquafine High Efficiency Cation Ion Exchange Resin |             |             |             |             |

# 185 TAN



This system uses Anion exchange resin to remove color caused by organic decay - greatly improving aesthetics and preventing costly staining.-



| Specifications                          | WG185TAN10   | WG185TAN15  | WG185TAN20  | WG185TAN30  |
|---|--|-------------|-------------|-------------|
| Purolite 850 Models*                    | 2229   | 2143        | 2144        | 2145        |
| Purolite 860 Models*                    | 2230   | 2146        | 2147        | 2148        |
| <b>Factory Settings - High Capacity</b> |  |             |             |             |
| Salt Used - Per Regeneration            | 12.0 lbs   | 18.0 lbs    | 24.0 lbs    | 36.0 lbs    |
| Water Used - Regeneration               | 64.3 gal   | 90.3 gal    | 124.6 gal   | 196.2 gal   |
| Tannins Removal                         | 2000 ppm   | 3000 ppm    | 4000 ppm    | 6000 ppm    |
| Resin Quantity - Cubic Feet             | 1.0 ft   | 1.5 ft      | 2.0 ft      | 3.0 ft      |
| Tank Size                               | 9x48   | 10x54       | 12x52       | 14x65       |
| Tank Jacket / Media Loaded              | Yes  | Yes         | No          | No          |
| Brine Tank / Cabinet Size (Inches)      | 18.1 x 34.5  | 20.3 x 37.4 | 20.3 x 37.4 | 23.0 x 40.5 |
| Salt Storage Capacity                   | 240 lbs  | 350 lbs     | 350 lbs     | 420 lbs     |
| Recommended Service Flow Rate           | 3.0 gpm  | 4.5 gpm     | 6.0 gpm     | 9.0 gpm     |
| Flow Rate @ 15 psi Pressure Drop        | 11.0 gpm   | 11.2 gpm    | 12.2 gpm    | 12.6 gpm    |
| Flow Rate @ 25 psi Pressure Drop        | 15.0 gpm   | 15.1 gpm    | 16.2 gpm    | 16.6 gpm    |
| Back Wash Flow Rate                     | 2.0 gpm  | 2.4 gpm     | 3.5 gpm     | 5.0 gpm     |
| Shipping Weight                         | 122 lbs  | 155 lbs     | 158 lbs     | 244 lbs     |
| Regeneration Type                       | Co-Current / Down Flow                               |             |             |             |
| Maximum Tannins                         | 3.0 ppm (Contact Customer Service for higher levels) |             |             |             |
| Plumbing Connections                    | Includes 3/4" 90°Elbows & 1" Straight NPT            |             |             |             |
| Resin Type                              | Canature Anion Resin                                 |             |             |             |
| Electrical Requirements                 | Input 120V 60 Hz - Output 12V 550mA                  |             |             |             |
| Water Pressure                          | Min. 20 - Max. 125 psi                               |             |             |             |

# 185 HTO

Rid your water of hardness & bad tastes and odor caused by chlorine, chloramines or organic matter.

The unique two tank system keeps the two media beds separate and allows for more carbon contact improving chlorine, chloramines and organic removal.

Because the carbon may need to be replaced before the softening resin, the two tank system allows for replacement without having to change the resin bed unlike many traditional mixed bed systems. Same benefit as separate systems but with cost of only one control valve.

### Features:

- ➔ Dedicated softening & carbon filtration tanks provide truly refined water
- ➔ NSF Certified control valve with electronic sensors, adjustable cycles & proven piston, seal & spacer design
- ➔ Reverse Flow regeneration preserves unused portion of softening bed from unnecessary exchange saving salt
- ➔ Precision brining calculates the exact amount of brine required to regenerate saving up to 30% more salt
- ➔ Backwash Frequency Preset for clean municipal water saves water by matching backwash to water quality need
- ➔ Soft Water brine tank refill keeps tank & injectors clean
- ➔ Automatic system refresh flushes stagnant water
- ➔ NSF Certified fibreglass pressure tank
- ➔ WQA Gold Seal Certified cation resin
- ➔ User-friendly backlit LCD display



| Specifications                       | WG185HTO25                                   | WG185HTO38  | WG185HTO50  | WG185HTO75  |
|--------------------------------------|--|-------------|-------------|-------------|
|                                      | 2188   | 2189        | 2190        | 2191        |
| <b>Factory Settings</b>              |  |             |             |             |
| Salt Used - Per Regeneration         | 6.0 lbs                                      | 9.0 lbs     | 12.0 lbs    | 18.0 lbs    |
| Water Used - Regeneration            | 86.4 gal                                     | 148 gal     | 162.4 gal   | 224.8 gal   |
| Hardness Removal - Grains            | 25,000                                       | 37,500      | 50,000      | 75,000      |
| Tank #1 Carbon Quantity - Cubic Feet | 1.0 ft                                       | 1.50 ft     | 2.0 ft      | 3.0 ft      |
| Tank #2 Resin Quantity - Cubic Feet  | 1.0 ft                                       | 1.50 ft     | 2.0 ft      | 3.0 ft      |
| Tank Size                            | 9x48   | 10x54       | 12x52       | 14x65       |
| Tank Jacket / Media Loaded           | Yes  | Yes         | No          | No          |
| Brine Tank / Cabinet Size (Inches)   | 18.1 x 34.5                                  | 18.1 x 34.5 | 20.3 x 37.4 | 23.0 x 40.5 |
| Salt Storage Capacity                | 240 lbs                                      | 240 lbs     | 350 lbs     | 420 lbs     |
| Flow Rate @ 15 psi Pressure Drop     | 7.2 gpm                                      | 7.4 gpm     | 9.0 gpm     | 9.2 gpm     |
| Flow Rate @ 25 psi Pressure Drop     | 10.0 gpm                                     | 10.1 gpm    | 11.9 gpm    | 12.1 gpm    |
| Back Wash Flow Rate                  | 2.4 gpm                                      | 3.5 gpm     | 4.0 gpm     | 5.0 gpm     |
| Shipping Weight                      | 154 lbs                                      | 171 lbs     | 214 lbs     | 232 lbs     |
| Regeneration Type                    | Counter Current / Up Flow                    |             |             |             |
| Plumbing Connections                 | Includes 3/4" 90°Elbows & 1" Straight NPT    |             |             |             |
| Resin Type                           | Canature 8% High Capacity Ion Exchange Resin |             |             |             |
| Carbon Type                          | Catalytic Carbon                             |             |             |             |
| Electrical Requirements              | Input 120V 60 Hz - Output 12V 650mA          |             |             |             |
| Water Temperature                    | Min 39 - Max. 100 degrees Fahrenheit         |             |             |             |
| Water Pressure                       | Min. 20 - Max. 125 psi                       |             |             |             |

# 185 HEDP

On very hard water supplies (> 75 gpg), a common problem with single tank water softeners is the occurrence of hardness leakage or 'slippage' as the extreme hardness will find a channel through the resin bed.

The WaterGroup High-Efficiency Dual Pass (HEDP) Water Softener uses a two tank system to prevent this problem. The first tank acts as the workhorse by significantly reducing the water hardness. The second tank acts as a 'polisher' and prevents slippage as the overpowering high hardness condition has been significantly reduced. This also increases the contact time with the softening resin meaning more consistent, softer water.

Salt efficiency is even more important on high hardness situations. The Novo HEDP offers salt-efficient reverse flow regeneration with precision brining for ultimate salt savings.

### Features:

- ➔ Two tank system provides softer, more consistent water quality and prevents hardness slippage which can occur in single tank systems
- ➔ Perfect for high hardness (typically > 75 gpg) residential and light commercial applications such as boiler feed systems
- ➔ More cost effective than larger single tank systems
- ➔ Reverse Flow Regeneration preserves unused portion of softening bed from unnecessary exchange saving salt



| Specifications                      | WG185HEDP50                                  | WG185HEDP75 | WG185HEDP100 | WG185HEDP125 |
|-------------------------------------|--|-------------|--------------|--------------|
|                                     | 2192   | 2193        | 2194         | 2195         |
| <b>Factory Settings</b>             |  |             |              |              |
| Salt Used - Per Regeneration        | 12.0 lbs                                     | 18.0 lbs    | 24.0 lbs     | 30.0 lbs     |
| Water Used - Regeneration           | 86.4 gal                                     | 148 gal     | 162.4 gal    | 224.8 gal    |
| Hardness Removal - Grains           | 50,000                                       | 75,000      | 100,000      | 125,000      |
| Tank #1 Resin Quantity - Cubic Feet | 1.0 ft                                       | 1.50 ft     | 2.0 ft       | 2.5 ft       |
| Tank #2 Resin Quantity - Cubic Feet | 1.0 ft                                       | 1.50 ft     | 2.0 ft       | 2.5 ft       |
| Tank Size                           | 9x48   | 10x54       | 12x52        | 13x54        |
| Tank Jacket / Media Loaded          | Yes  | Yes         | No           | No           |
| Brine Tank / Cabinet Size (Inches)  | 20.3 x 37.4                                  | 23.0 x 40.5 | 23.0 x 40.5  | 23.0 x 40.5  |
| Salt Storage Capacity               | 350 lbs                                      | 420 lbs     | 420 lbs      | 420 lbs      |
| Flow Rate @ 15 psi Pressure Drop    | 7.2 gpm                                      | 7.4 gpm     | 9.0 gpm      | 9.2 gpm      |
| Flow Rate @ 25 psi Pressure Drop    | 10.0 gpm                                     | 10.1 gpm    | 11.9 gpm     | 12.1 gpm     |
| Back Wash Flow Rate                 | 2.0 gpm                                      | 2.4 gpm     | 3.5 gpm      | 4.0 gpm      |
| Shipping Weight                     | 184 lbs                                      | 201 lbs     | 244 lbs      | 262 lbs      |
| Regeneration Type                   | Counter Current / Up Flow                    |             |              |              |
| Plumbing Connections                | Includes 3/4" 90°Elbows & 1" Straight NPT    |             |              |              |
| Resin Type                          | Canature 8% High Capacity Ion Exchange Resin |             |              |              |
| Electrical Requirements             | Input 120V 60 Hz - Output 12V 650mA          |             |              |              |
| Water Temperature                   | Min 39 - Max. 100 degrees Fahrenheit         |             |              |              |
| Water Pressure                      | Min. 20 - Max. 125 psi                       |             |              |              |

# 185 NeutraSoft Two Tank Water Conditioning System

## Neutralize Corrosiveness & Remove Hardness to Protect Fixtures, Pipes & Appliances

Acidic waters on contact slowly dissolve the Calcite media contained in the first tank to raise the pH which reduces the potential leaching of copper, lead and other metals typically found in plumbing systems.

As the Calcite neutralizes the water, it will increase the hardness of the water. The second tank contains cation exchange resin to remove the hardness leaving you with pH balanced, luxuriously soft water.



### Features:

- ➔ Economical two tank system is operated using one control valve. Simplifies installation and lowers cost.
- ➔ Dome hole neutralizing tank allows for easy replenishment of consumable calcite media
- ➔ Exclusive WG 185UF Series control valve with reliable electronic sensors, piston, seals and spacer technology
- ➔ High-efficiency upflow regeneration for ultimate salt savings and softer water
- ➔ Time saving quick connect fittings for faster, easier installation
- ➔ Factory installed one-piece bypass with incorporated meter
- ➔ Fully adjustable cycle times
- ➔ Meter Immediate, Meter Delayed, Meter with Day Override
- ➔ Integrated turbine meter
- ➔ 48 hour self charging battery back-up keeps time-of-day stored while program settings are kept in permanent memory
- ➔ Large user friendly color display shows time of day, total remaining capacity, and flow indication
- ➔ Simple electronics and programming.
- ➔ Lifetime Warranty on NSF Certified tank
- ➔ Seven year warranty on NSF Certified control valve

| Specifications                     | WG185HNU15                                   |
|------------------------------------|--|
|                                    | 2196   |
| Service Flow Rates                 |  |
| Normal                             | 5.0 gpm                                      |
| Peak                               | 8.0 gpm                                      |
| Backwash Flow Rate                 | 5.0 gpm                                      |
| Filter Media Volume - Cubic Feet   | 1.5 ft                                       |
| Resin Quantity - Cubic Feet        | 1.5 ft                                       |
| Tank Size                          | 10x54  |
| Tank Jacket / Media Loaded         | No   |
| Brine Tank / Cabinet Size (Inches) | 18.1 x 34.5                                  |
| Salt Storage Capacity              | 240 lbs                                      |
| Shipping Weight                    | 311 lbs                                      |
| Regeneration Type                  | Counter Current / Up Flow                    |
| Plumbing Connections               | Includes 3/4" 90° Elbows & 1" Straight NPT   |
| Resin Type                         | Canature 8% High Capacity Ion Exchange Resin |
| pH Adjustment Media                | Canature Calcite                             |
| Electrical Requirements            | Input 120V 60 Hz - Output 12V 650mA          |
| Water Temperature                  | Min 39 - Max. 100 degrees Fahrenheit         |
| Water Pressure                     | Min. 20 - Max. 125 psi                       |



*Dome hole port on tank allows for easy replenishment of Calcite neutralizing media*

**AQUA FLO**  
PLATINUM  
**AQUA FLO**

Reverse Osmosis  
Ultra Filtration  
Under Sink Filtration  
Designer Faucets  
& Accessories





# Aqua Flo Platinum QCRO & QCUF Drinking Water Systems

## Customized Drinking Water

Water conditions can vary even in the same community. The Aqua Flo Platinum QCRO System can be configured to meet your specific requirements. There are ten interchangeable filters with a variety of treatment options that can be tailored to local water conditions, so your water is the best it can be.

If you're concerned about RO reject water or RO drain line makes installation difficult, we offer UltraFiltration (UF).\* The UF does not have a drain line to run, your cost is lesser than RO and there is no waste.

The innovative QC twist and lock design makes service simple. Twist off the old cartridge and twist on the new. No messy sump removal. Aqua Flo Platinum HP systems make drinking water better and life easier.

\* Check with water treatment specialist to recommend you an RO or UF system depending on your untreated water quality.

**AQUA FLO**  
PLATINUM



“The innovative QC twist and lock design makes service simple.”

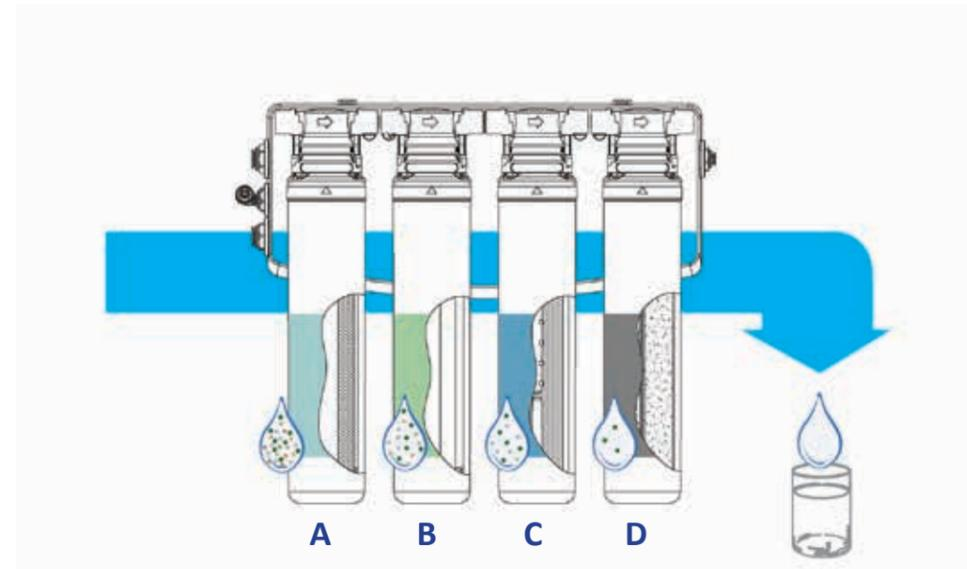

Quick glance on how Aqua Flo Platinum QCRO and QCUF works on water

**A Sediment Filters.** Screens out sediments and particles.

**B Carbon Filters.** Improve water's taste and odor, including chlorine odor reduction.

**C Reverse Osmosis or Ultra filtration.** Reverse Osmosis Membrane reduce dissolved substances. Several membranes capacities are available. Ultra Filtration membrane reduce undissolved solids down to 0.1 Micron

**D Several filter options are available** depending on your local conditions and requirements.

### Standard System Specifications\*

| Model                 | QCRO4V-50                    | QCRO4V-75                    | QCUF                      |
|-----------------------|------------------------------|------------------------------|---------------------------|
| Number of Stages      | 4                            | 4                            | 4                         |
| Stage 1 (Pre-Filter)  | Sediment Filter              | Sediment Filter              | Sediment Filter           |
| Stage 2 (Pre-Filter)  | Activated Carbon Filter      | Activated Carbon Filter      | Sediment Filter           |
| Stage 3 (Membrane)    | Thin Film Composite Membrane | Thin Film Composite Membrane | Ultra filtration Membrane |
| Stage 4 (Post-Filter) | Activated Carbon Filter      | Activated Carbon Filter      | Activated Carbon Filter   |
| Output (GPD)†         | 50                           | 75                           | 720                       |

\*Customized systems available upon request.

### Conditions for Use

|                         |                             |
|-------------------------|-----------------------------|
| Feed Water Pressure *   | 276-690 kPa (40-100 psi)    |
| Temperature             | 4-38° C (40-100° F)         |
| Community/Private       | Chlorinated/Non-Chlorinated |
| pH Range                | 3.0 - 11.0                  |
| Maximum TDS Level       | 2000 mg/L                   |
| Turbidity**             | <1.0 NTU                    |
| Maximum SDI ***         | <4.0                        |
| Hardness (CaCo3)        | <171 mg/L (<10gpg)          |
| Iron (Fe)               | <0.1 mg/L                   |
| Manganese (Mn)          | <0.05                       |
| Hydrogen Sulfide (H2S)  | 0                           |
| Residual Chlorine (Cl2) | <2.0                        |

\*\* Nephelometric Turbidity Unit  
\*\*\* Silt Density Index: Value stated in SDI units  
† Manufacturer's output specification only with inlet conditions of 345 kPa (50 psig), 25°C (77°F), going to atmosphere.  
Notes:  
\* Pressure Regulator is recommended for feed water pressures exceeding 552 kPa (80 psig). The performance of a reverse osmosis membrane is highly dependent upon pressure, temperature and TDS. The actual volume of product water and rejection percentage will vary with differences from the test conditions that membrane ratings are based upon. These drinking water systems are not intended to be used for the treatment of water that is microbiologically unsafe or of unknown quality.  
Storage tank capacity is dependent on pressure. Example: with a 7 psi precharge, the drawdown volume is 2.16 gal at 60 psi, 1.79 gal at 40 psi for the storage tank shown

Easy maintenance of service components including line check valve and autoshut off

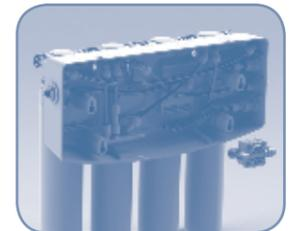

## Filter Cartridge and Single Stage Standalone System Specifications

|                                      | Sediment Filter  | Carbon Block Filter     |           | GAC Carbon Filter                | pH Booster Filter Cartridge                               | UF (Hollow Fiber) Membrane         | Carbon Block - 1 Mic Filter                    | Scale Reduction |
|--------------------------------------|------------------|-------------------------|-----------|----------------------------------|---|------------------------------------|--|-----------------|
| <b>Purpose</b>                       | Sediment Removal | Chlorine Taste and Odor |           | Polishing - Taste and Odor       | Raise pH of water and removal of chlorine, taste and odor | Ultra Fine Filtration              | Chlorine Taste and Odor, Particulate Reduction | Scale Inhibitor |
| <b>Type</b>                          | Polypropylene    | Carbon Block            |           | Granular Activated Carbon Filter | pH Booster and Remineralizer                              | Hollow Fiber Mechanical Filtration | Carbon Block                                   | Scale Reduction |
| <b>Micron</b>                        | 5                | 5                       | 50        | -                                | -   | 0.2                                | 1  |                 |
| <b>Capacity*</b>                     | 2000 gallons     |                         |           |                                  | To be changed every 6 months                              | To be changed every 12 months      | 750 Gallons                                    | 1500 gallons    |
| <b>Minimum Flow Rate @ 60psi</b>     | 0.5 gal/min      |                         |           |                                  |   |                                    |  |                 |
| <b>Single Stage System Model #**</b> | SEDQC1/4         | CBQC1/4                 | CB50QC1/4 | GACQC1/4                         | PHQC1/4   | UFQC1/4                            | CB1QC1/4                                       | SCALE-QC1/4     |

\* May vary depending on water quality \*\* Single Stage Standalone System Port Connection Size - 1/4" Quick Connect

## RO Membrane

|                                       |                              |
|---------------------------------------|------------------------------|
| <b>Purpose</b>                        | TDS Reduction                |
| <b>Type</b>                           | Thin film Composite Membrane |
| <b>Recovery</b>                       | 25%                          |
| <b>TDS Reduction %</b>                | 95%                          |
| <b>Rating</b>                         | 50 and 75 GPD                |
| <b>Minimum Flow Rate @ 60psi</b>      | 0.5 gal/min                  |
| <b>Quick Change Filter Dimensions</b> | 7.54 x 30.9 (2.96" x 12.17") |
| <b>Inlet/Outlet Connections</b>       | 1/4" Quick Connect           |
| <b>Working Temperature Range</b>      | 4-38° C (40-100° F)          |
| <b>Working Pressure Range</b>         | 207-828 kPa (30-120 psi)     |

| PART #  | DESCRIPTION   |
|---|---|
| <b>Aqua Flo Platinum QCRO (Quick Change) Reverse Osmosis</b>      |   |
| 1340302-60  | QCRO4V-50 4 STAGE, 50GPD, METAL TANK, STD CHROME AG FAUCET                            |
| 1340302-60-A  | QCRO4V-50 4 STAGE, 50GPD, METAL TANK, 50 MICRON CARBON, STD CHROME AG FAUCET          |
| 1340302-60-D  | QCRO4V-50 4 STAGE, 50GPD, METAL TANK, DELUXE CHROME AG VS888 FAUCET                   |
| 1340303-60  | QCRO4V-75 4 STAGE, 75GPD, METAL TANK, STD CHROME AG FAUCET                            |
| 1340303-60-A  | QCRO4V-75 4 STAGE, 75GPD, METAL TANK, 50 MICRON CARBON, STD CHROME AG FAUCET          |
| 1340303-60-D  | QCRO4V-75 4 STAGE, 75GPD, METAL TANK, DELUXE CHROME AG VS888 FAUCET                   |
| <b>Aqua Flo Platinum QCUF (Quick Change) Ultra Filtration</b>     |   |
| 1340201-60  | QCUF 4 STAGE, ULTRAFILTRATION, STD FAUCET   |
| 1340201-60-D  | QCUF 4 STAGE, ULTRAFILTRATION, DELUXE CHROME AG VS888 FAUCET                          |
| 1340201-60-A  | QCUF 4 STAGE, ULTRAFILTRATION, STD FAUCET, 50 MICRON CARBON                           |
| 1340201-60-A-D  | QCUF 4 STAGE, ULTRAFILTRATION, DELUXE CHROME AG VS888 FAUCET, 50 MICRON CARBON        |
| 1340201-60-A-D-S  | QCUF 4 STAGE, ULTRAFILTRATION, DELUXE BRIGHT NICKEL AG VS888 FAUCET, 50 MICRON CARBON |
| <b>Aqua Flo Platinum QC Single Filters (c/w Mounting Bracket)</b> |   |
| 41407001-14   | SEDQC1/4 SEDIMENT FILTER  |
| 41407002-14   | CBQC1/4 CARBON BLOCK FILTER   |
| 41407006-14   | CB50QC1/4 CARBON BLOCK FILTER - 50 MICRON   |
| 41407004-14   | GACQC1/4 GAC CARBON FILTER  |
| 41407007-14   | PHQC1/4 pH BOOSTER FILTER   |
| 41407005-14   | UFQC1/4 ULTRA FILTRATION (HOLLOW FIBRE) MEMBRANE                                      |
| 41407009-14   | CB1QC1/4 CARBON BLOCK FILTER - 1 MICRON   |
| 41407010-14   | SCALEQC1/4 SCALELESS FILTER   |
| <b>Aqua Flo Platinum Quick Change Replacement Filters</b>         |   |
| 41407001  | SEDIMENT FILTER   |
| 41407002  | CARBON BLOCK FILTER   |
| 41407006  | CARBON BLOCK FILTER -50 MICRON  |
| 41407004  | GAC CARBON FILTER   |
| 41407007  | pH BOOSTER FILTER   |
| 41407005  | UF (HOLLOW FIBER) MEMBRANE  |
| 41407009  | CARBON BLOCK - 1 MICRON   |
| 41407010  | SCALELESS   |
| 41407003  | RO MEMBRANE 50 GPD  |
| 41407008  | RO MEMBRANE 75 GPD  |
| 41407011  | ANNUAL REPLACEMENT FILTER KIT FOR QCRO (2 SEDIMENT / 3 CARBON BLOCK)                  |

\*Note: Two Carbon filters required on most standard RO and UF system configurations

# Aqua Flo Platinum 1240 Series

Aqua Flo Platinum 1240's advanced reverse osmosis drinking water systems are a natural and economical solution for providing your family with high quality drinking water. With a space-saving ultra slim profile, the system tucks neatly under your kitchen sink providing bottled water quality right from your very own tap.

All systems are backed by a two year limited warranty. The Smartap® water quality monitor found on the Push Button designated models is backed by a five year limited warranty.

## All models feature:

- ➔ High quality reverse osmosis membrane
- ➔ 75 gallons per day
- ➔ Sediment pre-filtration
- ➔ Pre & Post Carbon block filtration
- ➔ 3/8" tubing from RO to tank and faucet for higher flow
- ➔ Chrome faucet
- ➔ Simple snap fit cover for ease of service
- ➔ New slim profile with integrated mounting bracket for easy, space saving installation
- ➔ Quick connect fittings
- ➔ Color coded tubing for ease of installation
- ➔ Plastic 3.0 gal Storage Tank



4VTFC75GPB



4VTFC75G

NOTE: All units ship with Plastic storage tank.

**AQUA FLO**  
PLATINUM

| PART #  | DESCRIPTION  |
|---|--|
| <b>Aqua Flo Platinum 1240 Series Reverse Osmosis Drinking Water Systems</b> |  |
| 1240203-60  | 4VTFC75G   |
| 1240303-60  | 4VTFC75G - PB  |
| 1240202-60A   | 4VTFC50G, 50 MICRON CARBON BLOCK   |
| <b>Aqua Flo Platinum 1240 Series Replacement Cartridges &amp; Membranes</b> |  |
| 41400076  | SEDIMENT/CARBON 'DUAL PURPOSE' FILTER FOR 3 VESSEL MODELS ONLY, BLUE CAP |
| 41400008  | STRING WOUND SEDIMENT FILTER FOR 4 VESSEL MODELS ONLY, BLACK CAP         |
| 41400009  | PRE-CARBON FOR 4 VESSEL & POST CARBON FOR 3 & 4 VESSEL MODELS, BLUE CAP  |
| 33001068  | 25 GPD TFC MEMBRANE, YELLOW CASE, BLACK TAPE, FOR 1230/1240 SERIES       |
| 33001033  | 50 GPD TFC MEMBRANE, YELLOW CASE, BLACK TAPE, FOR 1230/1240 SERIES       |
| 33001056  | 75 GPD TFC MEMBRANE, YELLOW CASE, BLACK TAPE, FOR 1230/1240 SERIES       |

# Aqua Flo Platinum 1240 Series

## Conditions for Use

| Source Water Supply Profile      |                               | Chemical Parameters                                | Max mg/L*      |
|----------------------------------|-------------------------------|--|----------------|
| Community / Private              | Chlorinated / Non-Chlorinated | Hardness (CaCO <sub>3</sub> )                      | <256 (<15 gpg) |
| Feed Water Pressure <sup>1</sup> | 242 - 690 kPa (35-100 psig)   | Iron (Fe)  | <0.1           |
| Temperature                      | 4° - 38°C (40° - 100°F)       | Manganese (Mn)                                     | <0.05          |
| pH Range                         | 3.0 - 11.0                    | Hydrogen Sulfide (H <sub>2</sub> S)                | 0.00           |
| Maximum TDS Level                | 2000 mg/L                     | Residual Chlorine (Cl <sub>2</sub> )               | <2.0           |
| Turbidity**                      | <1.0 NTU                      | ** Nephelometric Turbidity Unit * mg/L = ppm       |                |
| Maximum SDI***                   | <4.0                          | *** Silt Density Index. Value stated in SDI units. |                |

**Notes:**

- 1 Pressure Regulator is recommended for feed water pressures exceeding 552 kPa (80 psig).
- The performance of a reverse osmosis membrane is highly dependent upon pressure, temperature and TDS. The actual volume of product water and rejection percentage will vary with differences from the test conditions that membrane ratings are based upon.
- These drinking water systems are not intended to be used for the treatment of water that is microbiologically unsafe or of unknown quality.
- Storage tank capacity is dependent on pressure. Example: with a 7 psi precharge, the drawdown volume is 2.16 gal at 60 psi, 1.79 gal at 40 psi for the storage tank shown.
- This product is manufactured under one or more of the following U.S. patents: 5,045,197; 5,057,212; 5,221,473

## Booster Pump ( R/O feed water line booster pump)

Raises the water pressure and maintains it at the ideal level for the system to operate at maximum efficiency. Recommended for use on supplies with low pressure or high concentrations of total dissolved solids (TDS). The pump is self-priming and whisper-quiet. It runs on a 24VAC transformer (included) from a standard 120VAC electrical outlet.

System includes: Flexible mounting plate, quick connect fittings and a pressure shut-off switch.

**Item #: 70030001**  
**Model: RO Booster with Pressure Switch and Transformer for 25 to 75 Gallon per day Systems**

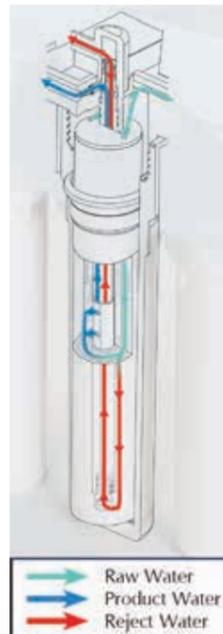

“Raises the water pressure and maintains it at the ideal level ...”

# Aqua Flo Reverse Osmosis Systems



## Fast, Simple & Sanitary Maintenance!

Quick connect disposable cartridges and membrane make for easy 'Do-It-Yourself' maintenance. With built in auto water shut-offs there is no need to turn off the water supply prior to maintenance.

Because traditional systems require the disinfection of the permanent housing canisters and involve more direct human contact, maintenance can take as much as an hour and if not done properly can result in a contaminated system.

Disposable cartridges changes in seconds and reduce contamination risk!

| PART #  | DESCRIPTION                                      |
|---|--|
| <b>Aqua Flo 475 Series Drinking Water Systems</b> |  |
| 20010023  | 475 PRO Series RO system                         |
| 20010024  | 475 PRO Series RO system w/BP                    |
| 20010025  | 475 PRO Series RO system (Air gap faucet)        |
| 20010026  | 475 PRO Series RO system w/BP (Air gap faucet)   |
| <b>Replacement Filters &amp; RO Membrane</b>      |  |
| 65010086  | SED-10 (Sediment Filter - 5 Micron)              |
| 65010088  | COC-10 Coconut Carbon (Pre & Post 10 Micron)     |
| 70010014  | RO Membrane 75 GPD TFC                           |
| 65010087  | CB-10 Carbon Block (Optional Filter - 10 Micron) |
| 65010089  | GAC-10 Granular Carbon (Optional Filter)         |

## Features:

- Four stage filtration: 5 micron sediment pre-filter, 10 micron coconut carbon pre & post filters, quick connect 75 GPD NSF Certified TFC membrane
- Bayonet-style 1/4 turn quick connect disposable cartridges with auto water shut-off
- Includes faucet and 3.0 gallon NSF Certified storage tank. (Designer faucets available)
- 3/8" tubing for high product flow rate from tank to faucet
- Quick connect fittings, inlet saddle and drain saddle, labelled tubing for easy installation
- Booster pump model with inlet solenoid raises water pressure to ideal level for maximum efficiency. Recommended on rural supplies with low pressure or high TDS
- Two year warranty (excluding consumable filter cartridges and RO membrane)
- Dimensions:  
 13"w x 14 1/2"h x 4 1/2" d No Pump  
 14 1/4"w x 16 1/2"h x 6 1/4" d Pump Model



**Change filters in seconds without turning off water! No tools required!**

**Booster Pump Model**



| Feed Water Guidelines |           |
|-----------------------|-----------|
| Maximum TDS           | 2000 ppm  |
| Hardness              | <7gpg     |
| Iron (Fe)             | <0.2ppm   |
| Manganese (Mn)        | <0.05ppm  |
| Hydrogen Sulfide      | 0.0ppm    |
| Turbidity             | <1.0NTU   |
| Feed Water Pressure   | 40-100psi |
| Temperature           | 40-100°F  |
| pH Range              | 3.0-11.0  |

# Aqua Flo Under Sink Filtration Systems

## 475QC Filters

The 475 Quick Change Filter Series offers 3, 2 & Single Stage options to provide solutions for a variety of water problems including sediment, rust, bad taste & odor.

### Features & Benefits:

- ➔ Low cost alternative to RO
- ➔ No reject water (100% water used)
- ➔ Leaves nutrients in water
- ➔ Ultra Filtration on system removes lead, VOC (pesticides, herbicides, chemicals), THM, chlorine, taste and odor and sediment down to 0.2 microns.
- ➔ Installation is quick and easy
- ➔ Quick change bayonet-style disposable cartridges are more sterile and can be changed in seconds
- ➔ Includes standard chrome faucet, inlet saddle valve, and 5ft 1/4" tubing
- ➔ No storage tank required
- ➔ Dimensions:
  - 3 stage - 11.8"w x 14.3"h x 4.5"d
  - 2 stage - 6.3"w x 13.4"h x 3.9"d
  - 1 stage - 2.8"w x 12.4"h x 3.2"d



**Change filters in seconds without turning off water! No tools required!**

| 475 QC Series Filter Systems |   |          |          |          |
|------------------------------|---|----------|----------|----------|
| PART #                       | DESCRIPTION                                 | Filter 1 | Filter 2 | Filter 3 |
| 20010201                     | 475QC-3 TRIPLE STAGE ULTRA FILTER           | SED      | UF       | COC      |
| 20010202                     | 475QC-2 DOUBLE STAGE DUAL FILTER            | SED      | COC      |          |
| 20010203                     | 475QC-1C SINGLE STAGE COCONUT CARBON FILTER | COC      |          |          |
| 20010204                     | 475QC-1S SINGLE STAGE SEDIMENT FILTER       | SED      |          |          |
| 20010205                     | 475QC-1G SINGLE STAGE GAC FILTER            | GAC      |          |          |

| 475 QC Series Replacement Filters |  |        |           |                    |
|-----------------------------------|--|--------|-----------|--------------------|
| PART #                            | DESCRIPTION                                | MICRON | FLOW RATE | CAPACITY (GALLONS) |
| 65010086                          | SEDIMENT FILTER SED-10 BLUE (475 Q SERIES) | 5      | 1 GPM     | 900                |
| 65010088                          | CARBON FILTER COC-10 PURPLE (475 Q SERIES) | 10     | 1 GPM     | 1,500              |
| 65010089                          | CARBON FILTER GAC-10 YELLOW (475 Q SERIES) | -      | 0.7 GPM   | 1,500              |
| 65010093                          | ULTRA FILTER UF-10 BLACK (475 Q SERIES)    | 0.2    | 0.7 GPM   | 1,500              |

# Aqua Flo Economy Reverse Osmosis System



| PART #  | DESCRIPTION                                 |
|---|---|
| <b>Aqua Flo Economy Drinking Water System</b> |   |
| 20010030                                      | 4 stage 75 GPD RO system                    |
| 20010031                                      | 4 stage 75 GDP RO system w Booster Pump     |
| 20010034                                      | 4 stage 75 GPD RO system (Air Gap)          |
| 20010035                                      | 4 stage 75 GDP RO system w Booster (AirGap) |
| <b>Replacement Filters &amp; RO Membrane</b>  |   |
| Item #  | Description                                 |
| 26081   | 5 Micron Pre-Filter - 10" Sediment          |
| 26273   | Pre & Post Filter - 10" Carbon              |
| 92022   | 75 GPD TFC Membrane                         |

### Booster Pump Model also includes:

- ➔ Pump mounted on RO to maintain constant water pressure
- ➔ Raises water pressure to ideal level for maximum efficiency
- ➔ Use on rural supplies with low pressure or highTDS
- ➔ Exclusive Auto Flush feature extends membrane life
- ➔ Self-priming and whisper quiet
- ➔ 24VAC transformer (included) from a standard 120VAC electrical outlet
- ➔ Flexible mounting plate, quick connect fittings and pressure shut-off switch

| Feed Water Guidelines |           |
|-----------------------|-----------|
| Maximum TDS           | 2000 ppm  |
| Hardness              | <7ppg     |
| Iron (Fe)             | <0.2ppm   |
| Hydrogen Sulfide      | 0.0ppm    |
| Turbidity             | <1.0NTU   |
| Feed Water Pressure   | 40-100psi |
| Temperature           | 40-100°F  |
| pH Range              | 3.0-11.0  |

Note: Pretreatment suggested if conditions exceed parameters. Must be installed on potable water.



### Features:

- ➔ Heavy duty glass filled polypropylene construction provides double the strength, toughness & durability compared to most other RO's which are typically constructed with ABS.
- ➔ TFC 75 GPD reverse osmosis membrane provides up to 99% Total Dissolved Solids (TDS) rejection
- ➔ Pre-filters 10" five (5) micron Spun Polypropylene Sediment Cartridge and 10" Activated Carbon Cartridge
- ➔ Post filter: 10" Activated Carbon Cartridge
- ➔ Choose from air gap or non-air gap chrome plated faucets
- ➔ 3.0 Gallon NSF Certified plastic storage tank
- ➔ 3/8" outlet tubing for higher flows
- ➔ Automatic shut-off valve
- ➔ Exclusive serviceable check valve eliminates spring 'chatter' noise common in other RO's
- ➔ Quick connect fittings for ease of installation
- ➔ Powder coated bracket
- ➔ Dual purpose wrench for use on membrane cap and filter housing
- ➔ Dimensions:
  - 15.0"w x 14.5"h x 6.1"d No Pump
  - 15.0"w x 17.7"h x 6.9"d Pump Model



#80010058 JG Undersink 3/8" connection angle stop / shut off  
#80010059 JG Undersink 1/4" connection angle stop / shut off

# Reverse Osmosis Storage Tanks

Flexwave is a line of RO accumulators and storage tanks for residential and light commercial applications.

Flexwave tanks are made in the USA and built to comply with NSF/ANSI Std 61. All Flexwave tanks have a 5 year warranty.



# 70031000 Quick Connect Ball Valve Assembly reduces 1" tank connection to John Guest Quick Connect RO ball valve 1/4" to 3/8" tubing.



Larger sizes available. Please contact Customer Service for details.  
 Tank precharge 20 PSI  
 Maximum Pressure 125 PSI  
 Maximum working temperature, internal & external 120F

## Materials of Construction

Tank top and bottom domes injection molded copolymer polypropylene. Shell extruded Polypropylene. Outer shell composite construction with fiberglass coated with epoxy resin. Base is injection molded high-impact ABS. 100% butyl diaphragm connected to a copolymer polypropylene bottom water chamber which allows for complete evacuation of the water chamber.

## Dimensions & Capacities

| Model  | Item # | Total Tank Volume |        | Height |    | Diameter |    | Connection | Total Weight |      |
|--------|--------|-------------------|--------|--------|----|----------|----|------------|--------------|------|
|        |        | Gallons           | Litres | In     | Cm | In       | Cm |            | In           | Lbs  |
| FWRO15 | 92372  | 15 Gal            | 56.8   | 25.6   | 65 | 16.5     | 42 | 1" NPT     | 19           | 8.6  |
| FWRO22 | 92374  | 22 Gal            | 83.3   | 34.1   | 87 | 16.5     | 42 | 1" NPT     | 25           | 11.3 |

## Quick Sizing Chart

| Model  | Item # | Total Tank Volume |        | Total Drawdown |        |         |        |
|--------|--------|-------------------|--------|----------------|--------|---------|--------|
|        |        |                   |        | 10/50          |        | 10/60   |        |
|        |        | Gallons           | Litres | Gallons        | Litres | Gallons | Litres |
| FWRO15 | 92372  | 15 Gal            | 56.8   | 9.3            | 35.2   | 10      | 37.9   |
| FWRO22 | 92374  | 22 Gal            | 83.3   | 13.6           | 51.5   | 14.7    | 55.6   |

# Designer Faucets

Designer RO faucets are a stylish addition to any kitchen. The NSF Certified lead-free ceramic disk faucets are available in many attractive finishes to coordinate with any decor. The faucets feature lead-free plastic water passages and lead-free brass gooseneck spouts that swivel 360 degrees for ease of use.



VS905

VS888

| PART #   | DESCRIPTION                      |
|----------|----------------------------------|
| 87588    | Faucet, VS888, Antique Brass     |
| 87589    | Faucet, VS888, Antique Wine      |
| 87581    | Faucet, VS888, Brushed Nickel    |
| 70040052 | Faucet, VS888, Oil Rubbed Bronze |
| 87580    | Faucet, VS888, Polished Chrome   |
| 87585    | Faucet, VS888, Satin Nickel      |
| 87584    | FAUCET, VS888, BLACK             |
| 70040045 | Faucet, VS905, Antique Brass     |
| 70040054 | Faucet, VS905, Antique Wine      |
| 87583    | Faucet, VS905, Brushed Nickel    |
| 87587    | Faucet, VS905, Oil Rubbed Bronze |
| 87582    | Faucet, VS905, Polished Chrome   |
| 87586    | Faucet, VS905, Satin Nickel      |
| 87591    | Stand, Display                   |
| 92710    | Faucet Colour Sample Display     |

| Specifications         | VS888                            | VS905                            |
|------------------------|----------------------------------|----------------------------------|
| Height                 | 11.5" (292mm)                    | 11.075" (281.32mm)               |
| Spout Reach            | 5.7" (146mm)                     | 4.75" (120mm)                    |
| Mounting Hole Diameter | 1/2" (12.5mm)                    | 1/2" (12.5mm)                    |
| Base Diameter          | 1.73" (44mm)                     | 1.76" (44.8mm)                   |
| Connection             | 1/4" compression nut fitting     | 1/4" compression nut fitting     |
| Operating Pressure     | 125 PSI/8.3BAR                   | 125 PSI/8.3BAR                   |
| Flow Rate              | 1.0 gpm/3.785lpm @35 PSI/2.32BAR | 1.0 gpm/3.785lpm @35 PSI/2.32BAR |
| Temp Rating            | 4°C/40°F to 70°C/158°F           | 4°C/40°F to 70°C/158°F           |
| Warranty               | 2 Years                          | 2 Years                          |

\* All mounting hardware included. A 3/8" quick connect faucet adapter fitting (#80010017) can be purchased separately.

## Color Sample Display #70040059



# RO Booster Pumps

## PAB8800 Series High Flow Booster Pump

### Key Operational Benefits:

- ➔ Boosts pressure 40 to 120 psi (adjustable)
- ➔ Used with membranes 50 to 120 GPD
- ➔ 15,000+ operating hours (estimated)
- ➔ Quiet – less than 52 DBA
- ➔ Can run dry without damage



### Features:

- ➔ Toughest, most durable pump on the market
- ➔ Adjustable max. outlet psi (regardless of feed pressure)
- ➔ Expels trapped air (no more air locks)
- ➔ Can be mounted with pump head up or horizontal
- ➔ More flow at extremely low inlet pressures
- ➔ New motor venting system to remove moisture
- ➔ EMI/RFI electronic noise suppression
- ➔ 100% final performance tested
- ➔ Available in 12VDC and 24VDC

## Aquatec 5800 Demand Pump

**OPERATION:** The 5800 pump can draw water from a holding tank and pressurize it, or boost the pressure from a low pressure source. They are designed to operate intermittently, but most versions can run continuously for several hour intervals. The pumps can be operated in demand mode controlled by an integral pressure switch, or in delivery mode controlled by an external power switching device. An integral bypass may be used to limit pressure.

**POWER:** 115V PSI: 60 GPM: 0.9

**MOUNTING:** A steel mounting base with four hollow rubber grommets is standard and included at no extra cost. The pump may be mounted in any position.

**FITTINGS:** The 5800 pump is offered with integral John Guest style quick connect fitting for 3/8" OD semi rigid tubing.



## KemFlo MD1050 Booster Pump

**DESCRIPTION:** 110/230 VAC, 75 GPD Booster pump 1.0 L.min, suitable for applications with 24VDC transformer

**SPECIFICATIONS:** Kemflo MD Series booster pump with 3/8" FNPT, made from NSF grade material high power flow rate and quality.

Meet ROHS standard.



| Item #   | Model                              |
|----------|------------------------------------|
| 92325    | KF - BOOSTER PUMP - MD1050         |
| 92317-1  | AQUATEC MODEL PAB8800 BOOSTER PUMP |
| 92341    | AQUATEC MODEL PD5800 DEMAND PUMP   |
| 70030035 | RO-75 BOOSTER PUMP                 |



**PORA**

PURA  
Ultraviolet  
Disinfection  
Systems



# PURA™ Ultraviolet Disinfection Systems

PURA Ultraviolet Disinfection Systems offer a broad range of solutions with features and flow rates to satisfy most applications.

The PURA UVB, UV20 and UVBB models offer a combination of UV disinfection and filtration in convenient, bracket mounted, all-in-one packages.

The PURA Gen 5 & 6 Series offer more advanced, axial-flow stainless steel systems with advanced monitoring.

The AB UV offers an entry level stainless steel UV system for lower price points.

The UV1-EPCB and UV ADDON Series offer smaller solutions for lower flow rate applications.



These systems are for the supplemental treatment of disinfected drinking water which has been treated or other drinking water which has been tested and deemed acceptable for human consumption by the state or local health agency having jurisdiction. These systems are designed to reduce normally occurring nonpathogenic nuisance organisms and is not intended for the treatment of contaminated water.

## Conditions For Use - All Lines

| Source Water Supply Profile      |                             | Chemical Parameters  | Max mg/L      |
|----------------------------------|-----------------------------|--|---------------|
| Feed Water Pressure <sup>1</sup> | 20 – 75psig (138 – 517kPa)  | Hardness (CaCO <sub>3</sub> )  | < 120 (7 gpg) |
| Feed Water Temperature           | 38° – 105°F (3.3° – 40.5°C) | Iron (Fe)  | < 0.3         |
| pH Range                         | 6.5 – 9.5                   | Manganese (Mn)   | < 0.05        |
| Total Dissolved Solids           | < 1500 mg/L                 | <sup>1</sup> Water Pressure must not exceed 75 psig (517 kPa) or a pressure regulator must be installed. |               |
| Total Suspended Solids           | < 10 mg/L                   |  |               |
| Turbidity                        | < 5 NTU                     |  |               |

The contaminants and other substances reduced by this water treatment device are not necessarily in your water. In addition, the presence of certain contaminants in your drinking water does not necessarily pose a health risk.

U.S. Patent #4,971,687

# PURA™ Gen 5 Residential Systems: Genesis H2O: Ultraviolet Disinfection System

## A Security System For Your Water

UV technology provides additional security for your water supply. It is proven to control microbiological (bacteria & virus) issues in water including **E.coli**, **Cryptosporidium**, and **Giardia Lamblia** without the use of chemicals.

## Gen 5 Residential Systems

### Features:

- Five models available (Gen5-3, 6, 10, 15 & 20)
- Colour user interface with full diagnostics and warnings including QR codes
- “Future-proof” expandability port for future upgrades and options
- Designed & manufactured to ASME pressure vessel standards
- Axial flow, 316L stainless steel reactor, polished reactors with integral sensor port to allow for sensor upgradeability in the future (comes standard with visual glow plug)
- Flow rates stated at 95% UVT at a dose of 30mJ/cm2
- User friendly bayonet style lamp connector (Quick ¼ turn removal. No extra tools required.)
- Reliable, industry proven low pressure (LP) coated UV lamps with ceramic bases for durability and a 9000 hour life (1 year)
- Constant current electronic controller (one controller for all systems) in a splash-proof case
- Warranty (refer to Owner’s Manual for complete details including conditions & exclusions):
  - Reactor Chamber – Ten (10) Year Limited
  - Electronics – Three (3) Year Limited
  - UV Lamps – One (1) Year Limited
  - Quartz Sleeves – One (1) Year Limited



### PURA GEN 5

| Item #   | Model                                |
|----------|--------------------------------------|
| 40030001 | UV STERILIZER PURA GEN 5-3 (3 gpm)   |
| 40030002 | UV STERILIZER PURA GEN 5-6 (6 gpm)   |
| 40030003 | UV STERILIZER PURA GEN 5-10 (10 gpm) |
| 40030004 | UV STERILIZER PURA GEN 5-15 (15 gpm) |
| 40030005 | UV STERILIZER PURA GEN 5-20 (20 gpm) |

| Parameter           | Level              |
|---------------------|--------------------|
| Hardness            | < 7 gpg (120 mg/L) |
| Iron (Fe)           | < 0.3ppm (mg/L)    |
| Manganese (Mn)      | < 0.05ppm (mg/L)   |
| Tannins             | < 0.1ppm (mg/L)    |
| Turbidity           | < 1 NTU            |
| Transmittance (UVT) | > 75%              |



# PURA™ Gen 6 Residential Systems

## A Security System For Your Water

UV technology provides additional security for your water supply. It is proven to control microbiological (bacteria & virus) issues in water including *E.coli*, *Cryptosporidium*, and *Giardia Lamblia* without the use of chemicals.

## Gen 6 Residential Systems

### Features:

- ➔ Four models available (Gen 6-6 , 10, 15 & 20)
- ➔ True 254nm Teflon® based UV sensor continuously measures UV output and visually displays output via controller
- ➔ Colour user interface with full diagnostics and warnings including QR codes
- ➔ “Future-proof” expandability port for future upgrades and options
- ➔ Axial flow, 304 stainless reactors
- ➔ Designed & manufactured to ASME pressure vessel standards
- ➔ Flow rates stated at 95% UVT at a dose of 30mJ/cm2
- ➔ User friendly bayonet style lamp connector (Quick ¼ turn removal. No extra tools required.)
- ➔ True gland seal retaining nut with positive stop
- ➔ Reliable, industry proven low pressure (LP) coated UV lamps with ceramic bases for durability and a 9000 hour life (1 year)
- ➔ Constant current electronic controller (one controller for all systems) in a splash-proof case
- ➔ Warranty (refer to Owner's Manual for complete details including conditions & exclusions):
  - Reactor Chamber - Ten (10) Year Limited
  - Electronics - Three (3) Year Limited
  - UV Lamps - One (1) Year Limited
  - Quartz Sleeves - One (1) Year Limited
  - UV Sensors - One (1) Year Limited

### PURA GEN 6

| Item #   | Model                                |
|----------|--------------------------------------|
| 40030006 | UV STERILIZER PURA GEN 6-6 (6 gpm)   |
| 40030007 | UV STERILIZER PURA GEN 6-10 (10 gpm) |
| 40030008 | UV STERILIZER PURA GEN 6-15 (15 gpm) |
| 40030009 | UV STERILIZER PURA GEN 6-20 (20 gpm) |

| Parameter           | Level              |
|---------------------|--------------------|
| Hardness            | < 7 gpg (120 mg/L) |
| Iron (Fe)           | < 0.3ppm (mg/L)    |
| Manganese (Mn)      | < 0.05ppm (mg/L)   |
| Tannins             | < 0.1ppm (mg/L)    |
| Turbidity           | < 1 NTU            |
| Transmittance (UVT) | > 75%              |



| MODEL                                   | GENESIS H2O EQUIPMENT SPECIFICATIONS   |  |   |  |  |
|---|--|--|---|--|--|
|   | GENESIS-5, Residential UV systems  |  |   |  |  |
|   | GEN5-3   | GEN5-6                                     | GEN5-10   | GEN5-15  | GEN5-20  |
| Flow Rate (@ 16 mJ/cm² @ 95% UVT)       | 6 GPM<br>23 lpm<br>1.4 m³/hr.  | 11 GPM<br>41 lpm<br>2.5 m³/hr.             | 20 GPM <sup>1</sup><br>77 lpm <sup>1</sup><br>4.6 m³/hr. <sup>1</sup> | 30 GPM <sup>2</sup><br>113.6 lpm <sup>2</sup><br>6.8 m³/hr. <sup>2</sup> | 39.2 GPM <sup>2</sup><br>150 lpm <sup>2</sup><br>8.9 m³/hr. <sup>2</sup> |
| Flow Rate (@ 30 mJ/cm² @ 95% UVT)       | 3 GPM<br>11.4 lpm<br>0.7 m³/hr.  | 6 GPM<br>22.7 lpm<br>1.4 m³/hr.            | 11 GPM<br>41 lpm<br>2.5 m³/hr.  | 15 GPM<br>56.8 lpm<br>3.4 m³/hr.   | 21 GPM<br>79 lpm<br>4.8 m³/hr.   |
| Flow Rate (@ 40 mJ/cm² @ 95% UVT)       | 2.4 GPM<br>9.1 lpm<br>0.5 m³/hr.   | 4.4 GPM<br>17 lpm<br>1.0 m³/hr.            | 8.3 GPM<br>31 lpm<br>1.9 m³/hr.                                       | 12 GPM<br>45.4 lpm<br>2.7 m³/hr.   | 16 GPM<br>59 lpm<br>3.6 m³/hr.   |
| Port Size                               | ½" MNPT  | ¾" MNPT                                    | ¾" MNPT   | 1" MNPT  | 1" MNPT  |
| Electrical                              | 90-265V/50-60Hz.   |  |   |  |  |
| Plug Type                               | North American, NEMA 5-15, 3-wire for all 110V   |  |   |  |  |
| Lamp Watts                              | 15   | 22   | 39  | 50   | 42   |
| Power (watts)                           | 20   | 30   | 49  | 62   | 51   |
| Replacement Lamp                        | RL-290   | RL-470                                     | RL-820  | RL-999   | RL-850   |
| Replacement Sleeve                      | RQ-290   | RQ-470                                     | RQ-820  | RQ-999   | RQ-850   |
| Reactor Dimensions                      | 2.5 x 14.3"<br>(6.4 x 36.4 cm)   | 2.5 x 21.3"<br>(6.4 x 54.2 cm)             | 2.5 x 35.2"<br>(6.4 x 89.5 cm)  | 2.5 x 40.0"<br>(6.4 x 101.6 cm)  | 3.5 x 36.1"<br>(8.9 x 91.7 cm)   |
| Chamber Material                        | Polished 304 Stainless Steel, A249 Pressure Rated Tubing   |  |   |  |  |
| Controller Dimensions                   | 6.8 x 3.6 x 3" (171.5 x 92.1 x 76.2 mm)  |  |   |  |  |
| Operating Pressure                      | 0.7-10.3 bar (10-150 psi)  |  |   |  |  |
| Operating Water Temperature             | 2-40° C (36-104° F)  |  |   |  |  |
| UV Monitor Port (upgradeability)        | No   | Yes  |   |  |  |
| Solenoid Output                         | Yes, but requires optional solenoid module   |  |   |  |  |
| 4-20 mA Output                          | Yes, but requires optional 4-20 mA module  |  |   |  |  |
| Lamp Change Reminder (audible & visual) | Yes  |  |   |  |  |
| Lamp-Out Indicator (audible & visual)   | Yes  |  |   |  |  |
| Shipping Weight                         | 3.3 kg. (7.3 lbs.)<br>3 kg. (7 lbs.) cubed   | 4.2 kg. (9.3 lbs.)<br>5 kg. (9 lbs.) cubed | 6.8 kg. (15.0 lbs.)<br>7 kg. (15 lbs.) cubed                          | 8.0 kg. (17.6 lbs.)<br>8 kg. (17 lbs.) cubed                             | 7.5 kg. (16.5 lbs.)<br>10 kg. (22 lbs.) cubed                            |
| Note:                                   | 1. based on flow velocity of 8.2 ft/sec (2.5 m/sec.), flow rate limited to 13.6 gpm (50 lpm) (3.1 m³/hr.) for ¾" port.<br>2. based on flow velocity of 8.2 ft/sec (2.5 m/sec.), flow rate limited to 22.1 gpm (84 lpm) (5.0 m³/hr.) for 1" port. |  |   |  |  |

### Sample Screens



NSF Certified Models Available. Contact Customer Service For Details.

\* See price list for specific item numbers

### Options



#### UV Sensor Module

Allows the 254nm UV wavelength to be measured and displayed via the GEN-H5 controller. The sensor plugs directly into the controller and is mounted in the sensor port located on all PURA Gen 5 units.



#### Solenoid Module

Used to power a remote normally closed solenoid valve (not included). Solenoid valve will close on lamp failure or when low UV conditions are detected by the sensor. Available in 110V MODSOL1 (Item # 40040006)

### REPLACEMENT PARTS

| System        | Lamps               | Sleeves             | Controller             |
|---------------|---------------------|---------------------|------------------------|
| Pura Gen 5-3  | RL-290<br>#40040013 | RQ-290<br>#40040040 | RC-B56.01<br>#40040066 |
| Pura Gen 5-6  | RL-470<br>#40040014 | RQ-470<br>#40040043 | RC-B56.01<br>#40040066 |
| Pura Gen 5-10 | RL-820<br>#40040015 | RQ-820<br>#40040045 | RC-B56.01<br>#40040066 |
| Pura Gen 5-15 | RL-999<br>#40040017 | RQ-999<br>#40040048 | RC-B56.01<br>#40040066 |
| Pura Gen 5-20 | RL-850<br>#40040016 | RQ-850<br>#40040046 | RC-B56.01<br>#40040066 |



| GENESIS H2O EQUIPMENT SPECIFICATIONS                |  |  |  |   |
|---|--|--|--|---|
| GENESIS-6, Residential monitored UV systems         |  |  |  |   |
| MODEL   | GEN6-6   | GEN6-10                                      | GEN6-15                                      | GEN6-20                                       |
| UV Flow Rate<br>(@ 16 mJ/cm <sup>2</sup> @ 95% UVT) | 11 GPM   | 20 GPM <sup>1</sup>                          | 30 GPM <sup>2</sup>                          | 39.2 GPM <sup>2</sup>                         |
|   | 41 lpm   | 77 lpm <sup>1</sup>                          | 113.6 lpm <sup>2</sup>                       | 150 lpm <sup>2</sup>                          |
|   | 2.5 m <sup>3</sup> /hr.  | 4.6 m <sup>3</sup> /hr. <sup>1</sup>         | 6.8 m <sup>3</sup> /hr. <sup>2</sup>         | 8.9 m <sup>3</sup> /hr. <sup>2</sup>          |
| UV Flow Rate<br>(@ 30 mJ/cm <sup>2</sup> @ 95% UVT) | 6 GPM  | 11 GPM                                       | 15 GPM                                       | 21 GPM  |
|   | 22.7 lpm   | 41 lpm                                       | 56.8 lpm                                     | 79 lpm  |
|   | 1.4 m <sup>3</sup> /hr.  | 2.5 m <sup>3</sup> /hr.                      | 3.4 m <sup>3</sup> /hr.                      | 4.8 m <sup>3</sup> /hr.                       |
| UV Flow Rate<br>(@ 40 mJ/cm <sup>2</sup> @ 95% UVT) | 4.4 GPM  | 8.3 GPM                                      | 12 GPM                                       | 16 GPM  |
|   | 17 lpm   | 31 lpm                                       | 45.4 lpm                                     | 59 lpm  |
|   | 1.0 m <sup>3</sup> /hr.  | 1.9 m <sup>3</sup> /hr.                      | 2.7 m <sup>3</sup> /hr.                      | 3.6 m <sup>3</sup> /hr.                       |
| Port Size   | ¾" MNPT  | ¾" MNPT                                      | 1" MNPT                                      | 1" MNPT                                       |
| Electrical  | 90-265V/50-60Hz.   |  |  |   |
| Plug Type   | North American, NEMA 5-15, 3-wire for all 110V   |  |  |   |
| Lamp Watts  | 22   | 39   | 50   | 42  |
| Power (watts)                                       | 30   | 49   | 62   | 51  |
| Replacement Lamp                                    | RL-470   | RL-820                                       | RL-999                                       | RL-850  |
| Replacement Sleeve                                  | RQ-470   | RQ-820                                       | RQ-999                                       | RQ-850  |
| Reactor Dimensions                                  | 2.5 x 21.3"<br>(6.4 x 54.2 cm)   | 2.5 x 35.2"<br>(6.4 x 89.5 cm)               | 2.5 x 40.0"<br>(6.4 x 101.6 cm)              | 3.5 x 36.1"<br>(8.9 x 91.7 cm)                |
| Chamber Material                                    | Polished 304 Stainless Steel, A249 Pressure Rated Tubing   |  |  |   |
| Controller Dimensions                               | 6.8 x 3.6 x 3" (171.5 x 92.1 x 76.2 mm)  |  |  |   |
| Operating Pressure                                  | 0.7-10.3 bar (10-150 psi)  |  |  |   |
| Operating Water Temperature                         | 2-40° C (36-104° F)  |  |  |   |
| UV Intensity Monitor                                | Yes  |  |  |   |
| Solenoid Output                                     | Yes, but requires optional solenoid module   |  |  |   |
| 4-20 mA Output                                      | Yes, but requires optional 4-20 mA module  |  |  |   |
| Lamp Change Reminder (audible & visual)             | Yes  |  |  |   |
| Lamp-Out Indicator (audible & visual)               | Yes  |  |  |   |
| Shipping Weight                                     | 4.2 kg. (9.3 lbs.)<br>5 kg. (9 lbs.) cubed   | 6.8 kg. (15.0 lbs.)<br>7 kg. (15 lbs.) cubed | 8.0 kg. (17.6 lbs.)<br>8 kg. (17 lbs.) cubed | 7.5 kg. (16.5 lbs.)<br>10 kg. (22 lbs.) cubed |
| Note:   | 1. based on flow velocity of 8.2 ft/sec (2.5 m/sec.), flow rate limited to <b>13.6 gpm</b> (50 lpm) (3.1 m <sup>3</sup> /hr.) for ¾" port<br>2. based on flow velocity of 8.2 ft/sec (2.5 m/sec.), flow rate limited to <b>22.1 gpm</b> (84 lpm) (5.0 m <sup>3</sup> /hr.) for 1" port |  |  |   |

### Sample Screens



NSF Certified Models Available. Contact Customer Service For Details.

\* See price list for specific item numbers

### Options



#### UV Sensor Module

Allows the 254nm UV wavelength to be measured and displayed via the GEN-H5 controller. The sensor plugs directly into the controller and is mounted in the sensor port located on all Pura Gen 6 units.



#### Solenoid Module

Used to power a remote normally closed solenoid valve (not included). Solenoid valve will close on lamp failure or when low UV conditions are detected by the sensor. Available in 110V MODSOL1 (Item # 40040006)

### REPLACEMENT PARTS

| System        | Lamps               | Sleeves             | Controller             |
|---------------|---------------------|---------------------|------------------------|
| Pura Gen 6-6  | RL-470<br>#40040014 | RQ-470<br>#40040043 | RC-B56.01<br>#40040066 |
| Pura Gen 6-10 | RL-820<br>#40040015 | RQ-820<br>#40040045 | RC-B56.01<br>#40040066 |
| Pura Gen 6-15 | RL-999<br>#40040017 | RQ-999<br>#40040048 | RC-B56.01<br>#40040066 |
| Pura Gen 6-20 | RL-850<br>#40040016 | RQ-850<br>#40040046 | RC-B56.01<br>#40040066 |

# PURA™ Gen H5 Residential Crossover High Flow Systems

## A Security System For Your Water

UV technology provides additional security for your water supply. It is proven to control microbiological (bacteria & virus) issues in water including *E. coli*, *Cryptosporidium*, and *Giardia Lamblia* without the use of chemicals.

## Gen H5 Residential Crossover High Flow Systems

### Features:

- ➔ Five models available (Gen H5-5, 10, 15, 25 & 40)
- ➔ Colour user interface with full diagnostics and warnings including QR codes
- ➔ "Future-proof" expandability port for future upgrades and options
- ➔ Axial flow, 316L stainless steel reactor, polished reactors with integral sensor port to allow for sensor upgradeability in the future (comes standard with visual glow plug)
- ➔ Designed & manufactured to ASME pressure vessel standards
- ➔ Flow rates stated at 95% UVT at a dose of 30mJ/cm<sup>2</sup>
- ➔ User friendly bayonet style lamp connector (Quick ¼ turn removal. No extra tools required.)
- ➔ True gland seal retaining nut with positive stop
- 0 Reliable, industry proven low pressure, high-output (LP-HO) coated UV lamps with ceramic bases for durability and a 10,000 hour life
- 0 Universal input, constant current electronic controller (one controller for all systems) in a splash-proof case
- 0 Warranty (refer to Owner's Manual for complete details including conditions & exclusions):
  - Reactor Chamber - Ten (10) Year Limited
  - Electronics - Three (3) Year Limited
  - UV Lamps - One (1) Year Limited
  - Quartz Sleeves - One (1) Year Limited

### PURA GEN H5

| Item #   | Model                                 |
|----------|---------------------------------------|
| 40030010 | UV STERILIZER PURA GEN H5-5 (5 gpm)   |
| 40030011 | UV STERILIZER PURA GEN H5-10 (10 gpm) |
| 40030012 | UV STERILIZER PURA GEN H5-15 (15 gpm) |
| 40030013 | UV STERILIZER PURA GEN H5-25 (25 gpm) |
| 40030014 | UV STERILIZER PURA GEN H5-40 (40 gpm) |

| Parameter           | Level              |
|---------------------|--------------------|
| Hardness            | < 7 gpg (120 mg/L) |
| Iron (Fe)           | < 0.3ppm (mg/L)    |
| Manganese (Mn)      | < 0.05ppm (mg/L)   |
| Tannins             | < 0.1ppm (mg/L)    |
| Turbidity           | < 1 NTU            |
| Transmittance (UVT) | > 75%              |



| GENESIS H2O EQUIPMENT SPECIFICATIONS                      |   |  |   |  |  |
|---|---|--|---|--|--|
| GENH-5, Residential Crossover UV systems, non-monitored   |   |  |   |  |  |
| MODEL   | GENH5-5   | GENH5-10   | GENH5-15  | GENH5-25   | GENH5-40   |
| Flow Rate (Industry Standard)                             | 4 GPM<br>15.1 lpm<br>0.9 m <sup>3</sup> /hr.  | 10 GPM<br>37.9 lpm<br>2.3 m <sup>3</sup> /hr.              | 14 GPM<br>53 lpm<br>3.2 m <sup>3</sup> /hr.                 | 25 GPM <sup>2</sup><br>95 lpm<br>5.7 m <sup>3</sup> /hr.   | 40 GPM<br>151 lpm<br>9.1 m <sup>3</sup> /hr.               |
| Alternate flow @ 16 mJ/cm <sup>2</sup> (US Public Health) | 8 GPM<br>30.3 lpm<br>1.8 m <sup>3</sup> /hr.  | 19 GPM <sup>3</sup><br>71.9 lpm<br>4.3 m <sup>3</sup> /hr. | 27 GPM <sup>3</sup><br>102.2 lpm<br>6.1 m <sup>3</sup> /hr. | 47 GPM <sup>3</sup><br>178 lpm<br>10.7 m <sup>3</sup> /hr. | 78 GPM <sup>3</sup><br>295 lpm<br>17.7 m <sup>3</sup> /hr. |
| Alternate flow @ 40 mJ/cm <sup>2</sup> (NSF/EPA)          | 3 GPM<br>11.4 lpm<br>0.7 m <sup>3</sup> /hr.  | 7 GPM<br>26.5 lpm<br>1.6 m <sup>3</sup> /hr.               | 11 GPM<br>41 lpm<br>2.5 m <sup>3</sup> /hr.                 | 19 GPM<br>72 lpm<br>4.3 m <sup>3</sup> /hr.                | 31 GPM<br>117 lpm<br>7 m <sup>3</sup> /hr.                 |
| Port Size   | 1/2" MNPT   | 3/4" MNPT  | 1" MNPT   | 1" MNPT  | 1 1/2" MNPT  |
| Electrical  | 90-265V/50-60Hz. (IEC power cords required)   |  |   |  |  |
| Power Plug  | North American, NEMA 5-15, 3-wire for all 110V  |  |   |  |  |
| Lamp Watts  | 18  | 34   | 45  | 67   | 101  |
| Power (watts)   | 20 (19 @ 230V)  | 38 (36 @ 230V)   | 57 (48 @ 230V)  | 73 (72 @ 230V)   | 115 (108 @ 230V)   |
| Replacement Lamp  | RL-210HO  | RL-330HO   | RL-420HO  | RL-600HO   | RL-950HO   |
| Replacement Sleeve  | RQ-210  | RQ-330   | RQ-420  | RQ-600   | RQ-950   |
| Reactor Dimensions  | 3.5 x 11.7"<br>(8.9 x 29.8 cm)  | 3.5 x 16.5"<br>(8.9 x 41.8 cm)                             | 3.5 x 20.0"<br>(8.9 x 50.8 cm)                              | 3.5 x 26.9"<br>(8.9 x 68.3 cm)                             | 3.5 x 40.7"<br>(8.9 x 103.4 cm)                            |
| Chamber Material  | 316L Stainless Steel, A249 Pressure Rated Tubing, Polished & Passivated   |  |   |  |  |
| Controller Dimension                                      | 8.6 x 4.2 x 3.5" (217.4 x 107.5 x 88.7 mm)  |  |   |  |  |
| Operating Pressure  | 0.7-10.3 bar (10-150 psi)   |  |   |  |  |
| Optimum Water Temperature                                 | 2-40° C (36-104° F)   |  |   |  |  |
| UV Monitor Port (upgradeability)                          | Yes, includes visual glow plug  |  |   |  |  |
| Solenoid Output   | Yes, but requires optional solenoid module  |  |   |  |  |
| 4-20 mA Output  | Yes, but requires optional 4-20 mA module   |  |   |  |  |
| Lamp Change Reminder (audible & visual)                   | Yes   |  |   |  |  |
| Lamp-Out Indicator (audible & visual)                     | Yes   |  |   |  |  |
| Shipping Weight   | 4.5 kg. (9.9 lbs.)<br>4 kg. (8 lbs.) cubed  | 5.4 kg. (11.9 lbs.)<br>5 kg. (11 lbs.) cubed               | 6.0 kg. (13.2 lbs.)<br>6 kg. (13 lbs.) cubed                | 7.2 kg. (15.9 lbs.)<br>8 kg. (16 lbs.) cubed               | 9.7 kg. (21.4 lbs.)<br>11 kg. (24 lbs.) cubed              |
| Note:   | 1. based on flow velocity of 8.2 ft/sec (2.5 m/sec.), flow rate limited to <b>13.6 gpm</b> (50 lpm) (3.1 m <sup>3</sup> /hr.) for 3/4" port<br>2. based on flow velocity of 8.2 ft/sec (2.5 m/sec.), flow rate limited to <b>22.1 gpm</b> (84 lpm) (5.0 m <sup>3</sup> /hr.) for 1" port<br>3. based on flow velocity of 8.2 ft/sec (2.5 m/sec.), flow rate limited to <b>52 gpm</b> (197 lpm) (11.8 m <sup>3</sup> /hr.) for 1 1/2" port |  |   |  |  |

\* See price list for specific item numbers

### Sample Screens



NSF Certified Models Available. Contact Customer Service For Details.

# PURA™ Gen H6 Residential Crossover High Flow Systems

## A Security System For Your Water

UV technology provides additional security for your water supply. It is proven to control microbiological (bacteria & virus) issues in water including *E.coli*, *Cryptosporidium*, and *Giardia Lamblia* without the use of chemicals.

## Gen H6 Residential Crossover High Flow Systems

### Features:

- ➔ Five models available (Gen H6-5, 10, 15, 25 & 40)
- ➔ True 254nm Teflon® based UV sensor continuously measures UV output via the controller
- ➔ Colour user interface with full diagnostics and warnings including QR codes
- ➔ "Future-proof" expandability port for future upgrades and options
- ➔ Axial flow, 316L stainless steel reactor
- ➔ Designed & manufactured to ASME pressure vessel standards
- ➔ Flow rates stated at 95% UVT at a dose of 30mJ/cm<sup>2</sup>
- ➔ User friendly bayonet style lamp connector (Quick 1/4 turn removal. No extra tools required.)
- ➔ True gland seal retaining nut with positive stop
- ➔ Reliable, industry proven low pressure, high-output (LP-HO) coated UV lamps with ceramic bases for durability and a 10,000 hour life
- ➔ Universal input, constant current electronic controller (one controller for all systems) in a splash-proof case
- ➔ Warranty (refer to Owner's Manual for complete details including conditions & exclusions):

- Reactor Chamber - Ten (10) Year Limited
- Electronics - Three (3) Year Limited
- UV Lamps - One (1) Year Limited
- Quartz Sleeves - One (1) Year Limited
- UV Sensors - One (1) Year Limited

### PURA GEN H6

| Item #   | Model                                 |
|----------|---------------------------------------|
| 40030015 | UV STERILIZER PURA GEN H6-5 (5 gpm)   |
| 40030016 | UV STERILIZER PURA GEN H6-10 (10 gpm) |
| 40030017 | UV STERILIZER PURA GEN H6-15 (15 gpm) |
| 40030018 | UV STERILIZER PURA GEN H6-25 (25 gpm) |
| 40030019 | UV STERILIZER PURA GEN H6-40 (40 gpm) |

| Parameter           | Level              |
|---------------------|--------------------|
| Hardness            | < 7 gpg (120 mg/L) |
| Iron (Fe)           | < 0.3ppm (mg/L)    |
| Manganese (Mn)      | < 0.05ppm (mg/L)   |
| Tannins             | < 0.1ppm (mg/L)    |
| Turbidity           | < 1 NTU            |
| Transmittance (UVT) | > 75%              |



## Options



### UV Sensor Module

Allows the 254nm UV wavelength to be measured and displayed via the GEN-H5 controller. The sensor plugs directly into the controller and is mounted in the sensor port located on all PURA Gen H5 units.



### Solenoid Module

Used to power a remote normally closed solenoid valve (not included). Solenoid valve will close on lamp failure or when low UV conditions are detected by the sensor. Available in 110V MODSOL1 (Item # 40040006)

### REPLACEMENT PARTS

| System         | Lamps                 | Sleeves             | Controller               |
|----------------|-----------------------|---------------------|--------------------------|
| Pura Gen H5-5  | RL-210HO<br>#40040018 | RQ-210<br>#40040039 | RCHO-B56.12<br>#40040074 |
| Pura Gen H5-10 | RL-330HO<br>#40040019 | RQ-330<br>#40040041 | RCHO-B56.12<br>#40040074 |
| Pura Gen H5-15 | RL-420HO<br>#40040020 | RQ-420<br>#40040042 | RCHO-B56.12<br>#40040074 |
| Pura Gen H5-25 | RL-600HO<br>#40040021 | RQ-600<br>#40040044 | RCHO-B56.12<br>#40040074 |
| Pura Gen H5-40 | RL-950HO<br>#40040022 | RQ-950<br>#40040047 | RCHO-B56.12<br>#40040074 |



| MODEL   | GENESIS H2O EQUIPMENT SPECIFICATIONS                                    |  |   |  |  |
|---|---|--|---|--|--|
|   | GENH-6, Residential Crossover monitored UV systems                      |  |   |  |  |
| Flow Rate (Industry Standard)                             | 4 GPM<br>15.1 lpm<br>0.9 m <sup>3</sup> /hr.                            | 10 GPM<br>37.9 lpm<br>2.3 m <sup>3</sup> /hr.              | 14 GPM<br>53 lpm<br>3.2 m <sup>3</sup> /hr.                 | 25 GPM <sup>2</sup><br>95 lpm<br>5.7 m <sup>3</sup> /hr.   | 40 GPM<br>151 lpm<br>9.1 m <sup>3</sup> /hr.               |
| Alternate flow @ 16 mJ/cm <sup>2</sup> (US Public Health) | 8 GPM<br>30.3 lpm<br>1.8 m <sup>3</sup> /hr.                            | 19 GPM <sup>1</sup><br>71.9 lpm<br>4.3 m <sup>3</sup> /hr. | 27 GPM <sup>2</sup><br>102.2 lpm<br>6.1 m <sup>3</sup> /hr. | 47 GPM <sup>2</sup><br>178 lpm<br>10.7 m <sup>3</sup> /hr. | 78 GPM <sup>3</sup><br>295 lpm<br>17.7 m <sup>3</sup> /hr. |
| Alternate flow @ 40 mJ/cm <sup>2</sup> (NSF/EPA)          | 3 GPM<br>11.4 lpm<br>0.7 m <sup>3</sup> /hr.                            | 7 GPM<br>26.5 lpm<br>1.6 m <sup>3</sup> /hr.               | 11 GPM<br>41 lpm<br>2.5 m <sup>3</sup> /hr.                 | 19 GPM<br>72 lpm<br>4.3 m <sup>3</sup> /hr.                | 31 GPM<br>117 lpm<br>7 m <sup>3</sup> /hr.                 |
| Port Size   | 1/2" MNPT   | 3/4" MNPT  | 1" MNPT   | 1" MNPT  | 1 1/2" MNPT  |
| Electrical  | 90-265V/50-60Hz. (IEC power cords required)                             |  |   |  |  |
| Power Plug  | North American, NEMA 5-15, 3-wire for all 110V                          |  |   |  |  |
| Lamp Watts  | 18  | 34   | 45  | 67   | 101  |
| Power (watts)   | 20 (19 @ 230V.)   | 38 (36 @ 230V.)  | 57 (48 @ 230V.)   | 73 (72 @ 230V.)  | 115 (108 @ 230V.)  |
| Replacement Lamp  | RL-210HO  | RL-330HO   | RL-420HO  | RL-600HO   | RL-950HO   |
| Replacement Sleeve  | RQ-210  | RQ-330   | RQ-420  | RQ-600   | RQ-950   |
| Reactor Dimensions  | 3.5 x 11.7"<br>(8.9 x 29.8 cm)  | 3.5 x 16.5"<br>(8.9 x 41.8 cm)                             | 3.5 x 20.0"<br>(8.9 x 50.8 cm)                              | 3.5 x 26.9"<br>(8.9 x 68.3 cm)                             | 3.5 x 40.7"<br>(8.9 x 103.4 cm)                            |
| Chamber Material  | 316L Stainless Steel, A249 Pressure Rated Tubing, Polished & Passivated |  |   |  |  |
| Controller Dimension                                      | 8.6 x 4.2 x 3.5" (217.4 x 107.5 x 88.7 mm)                              |  |   |  |  |
| Operating Pressure  | 0.7-10.3 bar (10-150 psi)   |  |   |  |  |
| Optimum Water Temperature                                 | 2-40° C (36-104° F)   |  |   |  |  |
| UV Intensity Monitor                                      | Yes   |  |   |  |  |
| Solenoid Output   | Yes, but requires optional solenoid module                              |  |   |  |  |
| 4-20 mA Output  | Yes, but requires optional 4-20 mA module                               |  |   |  |  |
| Lamp Change Reminder (audible & visual)                   | Yes   |  |   |  |  |
| Lamp-Out Indicator (audible & visual)                     | Yes   |  |   |  |  |
| Shipping Weight   | 4.5 kg. (9.9 lbs.)<br>4 kg. (8 lbs.) cubed                              | 5.4 kg. (11.9 lbs.)<br>5 kg. (11 lbs.) cubed               | 6.0 kg. (13.2 lbs.)<br>6 kg. (13 lbs.) cubed                | 7.2 kg. (15.9 lbs.)<br>8 kg. (16 lbs.) cubed               | 9.7 kg. (21.4 lbs.)<br>11 kg. (24 lbs.) cubed              |

**Sample Screens**



**NSF Certified Models Available. Contact Customer Service For Details.**

# PURA™ Gen 5 UV/Filter Rack System

## A Combination Water System For Your Entire Home or Cottage

Combining ultraviolet disinfection (UV) with whole-house filtration provides your home or cottage with clean, great-tasting water that you can rely on. UV is proven to control microbiological (bacteria & virus) issues in water including *E.coli*, *Cryptosporidium*, and *Giardia Lamblia* without the use of chemicals. Combining UV disinfection with whole-house sediment and/or carbon pre-treatment filters improves UV performance and the taste, smell and clarity of your water.



**Features:**

- ➔ Four models provide a range of flow rate and filter combination options suitable for your specific needs
- ➔ Models for 8 & 13 gpm flow rates
- ➔ All systems include 5 micron sediment removal pretreatment required for proper UV performance
- ➔ Optional 'high-flow' carbon filters to treat bad tastes and odors
- ➔ Pressure relief, high-flow polypropylene filter housings
- ➔ Colour user interface with full diagnostics and warnings including QR codes
- ➔ "Future-proof" expandability port for future upgrades and options
- ➔ Designed & manufactured to ASME pressure vessel standards
- ➔ Axial flow, 316L stainless steel polished reactors designed & manufactured to ASME pressure vessel standards
- ➔ Flow rates stated at 95% UVT at a dose of 30mJ/cm2
- ➔ User friendly bayonet style lamp connector (Quick 1/4 turn removal. No extra tools required.)
- ➔ Reliable, industry proven low pressure (LP) coated UV lamps with ceramic bases for durability and a 9000 hour life (1 year)
- ➔ Constant current electronic controller in a splash-proof case

**Options**



**UV Sensor Module**  
Allows the 254nm UV wavelength to be measured and displayed via the GEN-H5 controller. The sensor plugs directly into the controller and is mounted in the sensor port located on all GenH6 units.



**Solenoid Module**  
Used to power a remote normally closed solenoid valve (not included). Solenoid valve will close on lamp failure or when low UV conditions are detected by the sensor. Available in 110V MODSOL1 (Item # 40040006)

**REPLACEMENT PARTS**

| System         | Lamps                 | Sleeves             | Controller               |
|----------------|-----------------------|---------------------|--------------------------|
| Pura Gen H6-5  | RL-210HO<br>#40040018 | RQ-210<br>#40040039 | RCHO-B56.12<br>#40040074 |
| Pura Gen H6-10 | RL-330HO<br>#40040019 | RQ-330<br>#40040041 | RCHO-B56.12<br>#40040074 |
| Pura Gen H6-15 | RL-420HO<br>#40040020 | RQ-420<br>#40040042 | RCHO-B56.12<br>#40040074 |
| Pura Gen H6-25 | RL-600HO<br>#40040021 | RQ-600<br>#40040044 | RCHO-B56.12<br>#40040074 |
| Pura Gen H6-40 | RL-950HO<br>#40040022 | RQ-950<br>#40040047 | RCHO-B56.12<br>#40040074 |

**GEN 5 UV / FILTER RACK SYSTEM**

| Item #   | Model  |
|----------|--|
| 40030050 | UV STERILIZER / FILTER RACK SYSTEM PURA GEN 5 - 8R1    |
| 40030051 | UV STERILIZER / FILTER RACK SYSTEM PURA GEN 5 - 8R12   |
| 40030052 | UV STERILIZER / FILTER RACK SYSTEM PURA GEN H5 - 13R2  |
| 40030053 | UV STERILIZER / FILTER RACK SYSTEM PURA GEN H5 - 13R22 |

| Parameter           | Level              |
|---------------------|--------------------|
| Hardness            | < 7 gpg (120 mg/L) |
| Iron (Fe)           | < 0.3ppm (mg/L)    |
| Manganese (Mn)      | < 0.05ppm (mg/L)   |
| Tannins             | < 0.1ppm (mg/L)    |
| Turbidity           | < 1 NTU            |
| Transmittance (UVT) | > 75%              |

| PURA   |  |  |  |  |
|--|--|--|--|--|
| GENESIS H2O EQUIPMENT SPECIFICATIONS                 |  |  |  |  |
| GENESIS-5 Rack Mount Whole-House Combination Systems |  |  |  |  |
| MODEL  | GEN5-8R1   | GEN5-8R12                                      | GENH5-13R2                                       | GENH5-13R22                                      |
| Flow Rate<br>(@ 30 mJ/cm <sup>2</sup> @ 95% UVT)     | 8.0 GPM<br>30.3 lpm<br>1.8 m <sup>3</sup> /hr.           | 8.0 GPM<br>30.3 lpm<br>1.8 m <sup>3</sup> /hr. | 13.0 GPM<br>49.2 lpm<br>2.95 m <sup>3</sup> /hr. | 13.0 GPM<br>49.2 lpm<br>2.95 m <sup>3</sup> /hr. |
| 1st Filter Housing                                   | 10" 5 Micron Sediment                                    | 10" 5 Micron Sediment                          | 20" 5 Micron Sediment                            | 20" 5 Micron Sediment                            |
| 2nd Filter Housing                                   | N/A  | 20" High Capacity Carbon                       | N/A  | 20" High Capacity Carbon                         |
| Port Size  | 1" MNPT  |  |  |  |
| Electrical   | 90-265V/50-60Hz.   |  |  |  |
| Plug Type  | North American, NEMA 5-15, 3-wire for all 110V           |  |  |  |
| Lamp Watts   | 20 (standard-output lamp)                                |  | 45 (high-output lamp)                            |  |
| Power (watts)  | 23   | 23   | 57   | 57   |
| Max Current (amps)                                   | 1  |  |  |  |
| Chamber Dimensions                                   | 3.5 x 20.0" (8.9 x 50.8 cm)                              |  |  |  |
| Chamber Material                                     | Polished 316 Stainless Steel, A249 Pressure Rated Tubing |  |  |  |
| Controller Dimensions                                | 6.8 x 3.6 x 3" (17.2 x 9.2 x 7.6 cm)                     |  | 8.6 x 4.2 x 3.5" (21.7 x 10.8 x 8.9 cm)          |  |
| Operating Pressure                                   | 0.7-10.3 bar (10-150 psi)                                |  |  |  |
| Operating Water Temperature                          | 2-40° C (36-104° F)                                      |  |  |  |
| UV Monitor   | Optional (requires additional UV Sensor Module)          |  |  |  |
| Solenoid Output                                      | Yes, but requires optional solenoid module               |  |  |  |
| Dry Contacts   | Yes, but requires optional remote alarm module           |  |  |  |
| 4-20 mA Output                                       | Yes, but requires optional 4-20 mA module                |  |  |  |
| Lamp Change Reminder (audible & visual)              | Yes  |  |  |  |
| Lamp-Out Indicator (audible & visual)                | Yes  |  |  |  |
| Shipping Weight                                      | 18.5 lbs (8.4 Kg)  | 31.5 lbs (14.3 Kg)                             | 31.5 lbs (14.3 Kg)                               | 34.2 lbs (15.5 Kg)                               |

### Sample Screens



**NSF Certified Models Available. Contact Customer Service For Details.**

# PURA™ ABUV Series Ultraviolet Disinfection Systems

## PURA ABUV Series™

The PURA® ABUV Series is an entry level. Ultraviolet Water Disinfection System. The system will provide you with disinfected drinking water for years to come. These systems have been designed with high quality construction and innovative features.

Disinfection of water using ultraviolet light at a wavelength at 254nm is a chemical free way of destroying the DNA of microorganisms rendering them unable to replicate or cause infection. Installation of the system is straight forward and simple. Maintenance includes changing the lamp once a year and cleaning the quartz sleeve periodically.

The PURA® ABUV models are tested and certified by NSF against Standard 55 for Class B disinfection.

### Features:

- ➔ Lamp Failure Visual and Audible Alarm
- ➔ Lamp Change Reminder
- ➔ Countdown Lamp Timer
- ➔ 15V / 60Hz North American 3-Prong Grounded Plug

### Conditions for Use

Depending on the chemistry of the water to be disinfected by a PURA® Ultraviolet Water Disinfection System, additional pretreatment may be necessary. The following table outlines the basic parameters that need to be tested and treated should your water fall outside these parameters. An additional 5 micron sediment and housing is recommended as a minimum pretreatment to guard against any large particles that may mask the ultraviolet light and also assist with startup procedures.



| Dimensions    |            |            |             |  |
|---------------|------------|------------|-------------|--|
| A inches (cm) | 17.32 (44) | 23 (58.5)  | 31.5 (80)   |  |
| B inches (cm) | 2.5 (6.35) | 2.5 (6.35) | 2.5 (6.35)  |  |
| C inches (cm) | 4.33 (11)  | 4.33 (11)  | 4.45 (11.3) |  |
| D inches (cm) | 21.65 (55) | 27.56 (70) | 36.61 (93)  |  |

### Options



**UV Sensor Module**  
Allows the 254nm UV wavelength to be measured and displayed via the GEN-5 UV controller. The sensor plugs directly into the controller and is mounted in the sensor port located on all GenH6 units.



**Solenoid Module**  
Used to power a remote normally closed solenoid valve (not included). Solenoid valve will close on lamp failure or when low UV conditions are detected by the sensor. Available in 110V MODSOL1 (Item # 40040006)



**4-20mA Module** Used for signal transfer to a remote device such as a data logger or computer)



**Remote Alarm (Dry Contact) Module** Used for signal transfer to a remote alarm or dry contacts.

| Specifications   |                           |             |              |
|--|---------------------------|-------------|--------------|
| Item #   | 8880                      | 8881        | 8882         |
| Model #  | Buv-6                     | Buv-8       | Buv-12       |
| NSF Rated Flow Rate @ 16mJ/cm <sup>2</sup> @ 70% UVT - usgpm (l/min) | 5.5 (20.79)               | 7.8 (29.48) | 12 (45.36)   |
| Flow Rate @ 16 mJ/cm <sup>2</sup> @ 96% UVT - usgpm (l/min)          | 12 (45.36)                | 18.8 (71)   | 26 (98.28)   |
| Flow Rate @ 30 mJ/cm <sup>2</sup> @ 96% UVT - usgpm (l/min)          | 6.4 (24.2)                | 10 (37.8)   | 13.9 (52.5)  |
| Flow Rate @ 40 mJ/cm <sup>2</sup> @ 96% UVT - usgpm (l/min)          | 4.8 (18.14)               | 7.5 (28.35) | 10.4 (39.31) |
| Lamp Power (Watt)  | 21                        | 29          | 40           |
| Max. Current (Amp)   | 0.4                       | 0.4         | 0.5          |
| Inlet and Outlet Size NPT  | 1/2"                      | 3/4"        | 1"           |
| Weight lbs (kg)  | 6 (2.67)                  | 8 (3.57)    | 12 (5.36)    |
| Operating Pressure psi (kPa)   | 10-100 psi (69-689 kPa)   |             |              |
| Operating Temperature Range  | 36 to 104° F (2 to 40° C) |             |              |
| Electrical   | 100-240V - 50/60Hz        |             |              |
| Electrical Plug  | North American            |             |              |

# PURA™ Ultraviolet Disinfection Systems



## UVB Series™

PURA Product's patented UVB Series is designed to provide disinfected water at a flow rate of 2 gallons per minute. In addition to disinfection, water is filtered through our 0.5 micron Extended Pass Carbon Block (EPCB) filter. Our double and triple models provide you with additional filtration with sediment and activated carbon filters.

This compact All-in-One system installs with ease and can be used anywhere that clean, clear, good tasting disinfected water is needed. It is ideal for point-of-use applications like under the kitchen sink, office water coolers, water vending machines, boats, recreational vehicles, etc.

### Features:

- ➔ Electronic lamp indicator (LED)
- ➔ Standard voltage 115V

### Options:

- ➔ 220V/50Hz (2-Prong Euro plug)
- ➔ 12V DC
- ➔ Lamp Out Circuit (LOC) - (normally open) Safety monitor for alarm
- ➔ Lamp Out Circuit (LOC) - (normally closed) Safety monitor for solenoid shut off
- ➔ Three year warranty except on electrical components which are covered for a period of one year.

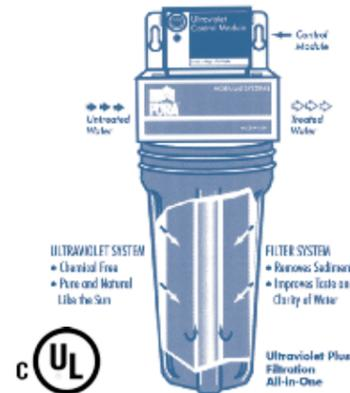

## Specifications & Performance UVB Series

| Item #   | Model Description         | # of sumps | Sump Type | Sump 1              | Sump 2                 | Sump 3         | Lamp # | Power Used | Flow Rates <sup>(1)</sup> GPM (L/min) | Dimensions H x W x D In. (cm)    | Shipping Weight Lbs. (Kg) | Inlet/Outlet Size |
|----------|---------------------------|------------|-----------|---------------------|------------------------|----------------|--------|------------|---------------------------------------|----------------------------------|---------------------------|-------------------|
| 15610111 | UVB1-EPCB                 | 1          | #10       | EPCB Carbon/UV      | none                   | none           | #11    | 14 Watts   | 2 (7.6)                               | 15 x 5.5 x 5.5 (38.1 x 14 x 14)  | 10.0 (4.5)                | 3/8" NPT          |
| 15610411 | UVB1-EPCB Normally Closed | 1          | #10       | EPCB Carbon/UV      | none                   | none           | #11    | 14 Watts   | 2 (7.6)                               | 15 x 5.5 x 5.5 (38.1 x 14 x 14)  | 10.0 (4.5)                | 3/8" NPT          |
| 15610511 | UVB1-EPCB Normally Open   | 1          | #10       | EPCB Carbon/UV      | none                   | none           | #11    | 14 Watts   | 2 (7.6)                               | 15 x 5.5 x 5.5 (38.1 x 14 x 14)  | 10.0 (4.5)                | 3/8" NPT          |
| 15620121 | UVB2-EPCB/SD              | 2          | #10       | 5 Micron Sed Filter | EPCB Carbon/UV         | none           | #11    | 14 Watts   | 2 (7.6)                               | 15 x 11 x 5.5 (38.1 x 27.9 x 14) | 15.0 (6.8)                | 3/8" NPT          |
| 15630131 | UVB3-EPCB/GC/SD           | 3          | #10       | 5 Micron Sed Filter | Granular Carbon Filter | EPCB Carbon/UV | #11    | 14 Watts   | 2 (7.6)                               | 15 x 16 x 5.5 (38.1 x 40.6 x 14) | 24.0 (10.9)               | 3/8" NPT          |

Note: (1) All flow rates shown will provide a UV dose of no less than 16,000 mW-s/cm<sup>2</sup> or greater.

# PURA™ Ultraviolet Disinfection Systems

## UV20 Series™

The PURA Product's UV20 Series is designed to provide disinfected water at a flow rate of 8 - 10 gallons per minute. This system is ideal for whole house water treatment. In addition to disinfection, the double and triple models provide filtration for the removal of sediment and chemical contaminants.

This ultraviolet water treatment system makes a perfect companion to water softeners, distillers, reverse osmosis and ozone systems. The UV20 Series has proven to be PURA Product's most popular product line and has created an industry standard in whole house disinfection.

### Features:

- ➔ Electronic lamp indicator (LED)
- ➔ Standard voltage 115V

### Options:

- ➔ 220V/50Hz (2-Prong Euro plug)
- ➔ 12V DC
- ➔ Lamp Out Circuit (LOC) - (normally open) Safety monitor for alarm
- ➔ Lamp Out Circuit (LOC) - (normally closed) Safety monitor for solenoid shut off
- ➔ Three year warranty except on electrical components which are covered for a period of one year.



## Specifications & Performance UV20 Series

| Item Number | Model Description            | # of sumps | Sump Type | Sump 1              | Sump 2                 | Sump 3 | Lamp # | Power Used | Flow Rates <sup>(1)</sup> GPM (L/min) | Dimensions H x W x D In. (cm)    | Shipping Weight Lbs. (Kg) | Inlet/Outlet Size |
|-------------|------------------------------|------------|-----------|---------------------|------------------------|--------|--------|------------|---------------------------------------|----------------------------------|---------------------------|-------------------|
| 15710100    | UV20-1                       | 1          | #20       | UV                  | none                   | none   | #20    | 22 Watts   | 10 (38)                               | 25 x 5.5 x 5.5 (63.5 x 14 x 14)  | 16.0 (7.3)                | 3/4" NPT          |
| 15710400    | UV20-1 Normally Closed       | 1          | #20       | UV                  | none                   | none   | #20    | 22 Watts   | 10 (38)                               | 25 x 5.5 x 5.5 (63.5 x 14 x 14)  | 16.0 (7.3)                | 3/4" NPT          |
| 15710500    | UV20-1 Normally Open         | 1          | #20       | UV                  | none                   | none   | #20    | 22 Watts   | 10 (38)                               | 25 x 5.5 x 5.5 (63.5 x 14 x 14)  | 16.0 (7.3)                | 3/4" NPT          |
| 15720121    | UV20-2 SD                    | 2          | #20       | 5 Micron Sed Filter | UV                     | none   | #20    | 22 Watts   | 10 (38)                               | 25 x 11 x 5.5 (63.5 x 27.9 x 14) | 23.0 (10.4)               | 3/4" NPT          |
| 15720421    | UV20-2 SD Normally Closed    | 2          | #20       | 5 Micron Sed Filter | UV                     | none   | #20    | 22 Watts   | 10 (38)                               | 25 x 11 x 5.5 (63.5 x 27.9 x 14) | 23.0 (10.4)               | 3/4" NPT          |
| 15720521    | UV20-2 SD Normally Open      | 2          | #20       | 5 Micron Sed Filter | UV                     | none   | #20    | 22 Watts   | 10 (38)                               | 25 x 11 x 5.5 (63.5 x 27.9 x 14) | 23.0 (10.4)               | 3/4" NPT          |
| 15730131    | UV20-3 SD/CB                 | 3          | #20       | 5 Micron Sed Filter | 10 Micron Carbon Block | UV     | #20    | 22 Watts   | 8 (30)                                | 25 x 16 x 5.5 (63.5 x 40 x 14)   | 33.0 (15.0)               | 3/4" NPT          |
| 15730431    | UV20-3 SD/CB Normally Closed | 3          | #20       | 5 Micron Sed Filter | 10 Micron Carbon Block | UV     | #20    | 22 Watts   | 8 (30)                                | 25 x 16 x 5.5 (63.5 x 40 x 14)   | 33.0 (15.0)               | 3/4" NPT          |
| 15730531    | UV20-3 SD/CB Normally Open   | 3          | #20       | 5 Micron Sed Filter | 10 Micron Carbon Block | UV     | #20    | 22 Watts   | 8 (30)                                | 25 x 16 x 5.5 (63.5 x 40 x 14)   | 33.0 (15.0)               | 3/4" NPT          |

Note: (1) All flow rates shown will provide a UV dose of no less than 16,000 mW-s/cm<sup>2</sup> or greater.

# PURA™ Ultraviolet Disinfection Systems

## UV BigBoy™ Series

The UV BigBoy Series is the most versatile commercial ultraviolet disinfection system on the market today. This 15 to 60 GPM series is manufactured with versatility in mind, and is virtually unlimited in the possible filter configurations and manifold sequences. The series is designed with the same traditional style that PURA has made an industry standard - worldwide.

One advantage of the UV BigBoy Series is the convenient manifold mounting rack. The rack can be used to configure up to four UV chambers in parallel or in series. This allows the user to achieve either a higher UV dosage or higher flow rate (up to 60 GPM).

This mounting rack configuration provides easy access for cleaning and maintenance to the individual units without the need to shut down the entire water distribution line. The standard LED lamp monitor provides a visual verification the lamp is in operation.

The UV BigBoy Series, with its capacity, versatility and cost, to be the world's most flexible, complete water disinfection system in its class.



### Features:

- ➔ Electronic lamp indicator (LED)
- ➔ Standard voltage 115V

### Options:

- ➔ 220V/50Hz (2-Prong Euro plug)
- ➔ 12V DC
- ➔ Lamp Out Circuit (LOC) - (normally open) Safety monitor for alarm
- ➔ Lamp Out Circuit (LOC) - (normally closed) Safety monitor for solenoid shut off
- ➔ Three year warranty except on electrical components which are covered for a period of one year.

## Specifications & Performance UV BigBoy Series

| Item #   | Model Description         | # of sumps | Sump Type | Sump 1              | Sump 2                 | Sump 3 | Lamp # | Power Used | Flow Rates <sup>(1)</sup> GPM (L/min) | Dimensions In. (cm) H x W x D         | Shipping Wgt. Lbs. (Kg) | Inlet/Outlet Size |
|----------|---------------------------|------------|-----------|---------------------|------------------------|--------|--------|------------|---------------------------------------|---------------------------------------|-------------------------|-------------------|
| 15810100 | UVBB-1                    | 1          | #20BB     | UV                  | none                   | none   | #20    | 22 Watts   | 15 (57)                               | 28 x 7.5 x 9.0<br>(71.1 x 19 x 22.9)  | 18.0<br>(8.2)           | 1-1/2" NPT        |
| 15810400 | UVBB-1<br>Normally Closed | 1          | #20BB     | UV                  | none                   | none   | #20    | 22 Watts   | 15 (57)                               | 28 x 7.5 x 9.0<br>(71.1 x 19 x 22.9)  | 18.0<br>(8.2)           | 1-1/2" NPT        |
| 15810500 | UVBB-1<br>Normally Open   | 1          | #20BB     | UV                  | none                   | none   | #20    | 22 Watts   | 15 (57)                               | 28 x 7.5 x 9.0<br>(71.1 x 19 x 22.9)  | 18.0<br>(8.2)           | 1-1/2" NPT        |
| 15820121 | UVBB-2                    | 2          | #20BB     | 5 Micron Sed Filter | UV                     | none   | #20    | 22 Watts   | 15 (57)                               | 28 x 15 x 9.0<br>(71.1 x 38.1 x 22.9) | 35.0<br>(15.9)          | 1-1/2" NPT        |
| 15820421 | UVBB-2<br>Normally Closed | 2          | #20BB     | 5 Micron Sed Filter | UV                     | none   | #20    | 22 Watts   | 15 (57)                               | 28 x 15 x 9.0<br>(71.1 x 38.1 x 22.9) | 35.0<br>(15.9)          | 1-1/2" NPT        |
| 15820521 | UVBB-2<br>Normally Open   | 2          | #20BB     | 5 Micron Sed Filter | UV                     | none   | #20    | 22 Watts   | 15 (57)                               | 28 x 15 x 9.0<br>(71.1 x 38.1 x 22.9) | 35.0<br>(15.9)          | 1-1/2" NPT        |
| 15830131 | UVBB-3                    | 3          | #20BB     | 5 Micron Sed Filter | 10 Micron Carbon Block | UV     | #20    | 22 Watts   | 15 (57)                               | 28 x 23 x 9.0<br>(71.1 x 58.4 x 22.9) | 54.0<br>(24.5)          | 1-1/2" NPT        |
| 15830431 | UVBB-3<br>Normally Closed | 3          | #20BB     | 5 Micron Sed Filter | 10 Micron Carbon Block | UV     | #20    | 22 Watts   | 15 (57)                               | 28 x 23 x 9.0<br>(71.1 x 58.4 x 22.9) | 54.0<br>(24.5)          | 1-1/2" NPT        |
| 15830531 | UVBB-3<br>Normally Open   | 3          | #20BB     | 5 Micron Sed Filter | 10 Micron Carbon Block | UV     | #20    | 22 Watts   | 15 (57)                               | 28 x 23 x 9.0<br>(71.1 x 58.4 x 22.9) | 54.0<br>(24.5)          | 1-1/2" NPT        |

## Specifications & Performance UV BigBoy Series

| Item #   | Model Description | # of sumps | Sump Type | Sump 1               | Sump 2               | Sump 3               | Sump 4 | Lamp # | Power Used | Flow Rates <sup>(1)</sup> GPM (L/min) | Dimensions In. (cm) H x W x D | Shipping Wgt. Lbs. (Kg) | Inlet/Outlet Size |
|----------|-------------------|------------|-----------|----------------------|----------------------|----------------------|--------|--------|------------|---------------------------------------|-------------------------------|-------------------------|-------------------|
| 15018001 | UVBB-R1           | 4          | #20BB     | empty <sup>(2)</sup> | empty <sup>(2)</sup> | empty <sup>(2)</sup> | UV     | #20    | 22 Watts   | 15 (57)                               | 45x34x18 (114x86x45)          | 65.0 (29.5)             | 1-1/2" NPT        |
| 15018201 | UVBB-R2           | 4          | #20BB     | empty <sup>(2)</sup> | empty <sup>(2)</sup> | UV                   | UV     | #20    | 44 Watts   | 30 (114)                              | 45x34x18 (114x86x45)          | 75.0 (34.0)             | 1-1/2" NPT        |
| 15018401 | UVBB-R4           | 4          | #20BB     | UV                   | UV                   | UV                   | UV     | #20    | 88 Watts   | 60 (227)                              | 45x34x18 (114x86x45)          | 91.0 (41.3)             | 1-1/2" NPT        |

# PURA™ Ultraviolet Disinfection Systems

## UV1-EPCB Series™

PURA Product's UV1-EPCB Series is a bright example of PURA Product's patented All-In-One concept. This product combines both ultraviolet disinfection with carbon filtration all in a very attractive and compact system.

The UV-1 Series is rated for 1 gallon per minute and uses either a 0.5 micron (EPCB) carbon block filter or a 10 micron (EPCB 10) carbon block filter. This easy to install system can be used as a stand alone or in conjunction with other water treatment products.

### Features:

- ➔ Compact Size
- ➔ Standard voltage 115V

### Options:

- ➔ 220V/50Hz (2-Prong Euro plug)
- ➔ 12V DC

## Specifications & Performance UV1-EPCB Series

| Item #   | Model Description | # of sumps | Sump Type | Sump Content   | Lamp # | Power Used | Flow Rates <sup>(1)</sup> GPM (L/min) | Dimensions In. (cm) H x W x D            | Shipping Wgt. Lbs. (Kg) | Inlet/Outlet Size |
|----------|-------------------|------------|-----------|----------------|--------|------------|---------------------------------------|--|-------------------------|-------------------|
| 15910111 | UV1-EPCB          | 1          | #10SL     | EPCB Carbon/UV | #10    | 10 Watts   | 1 (3.8)                               | 13.5 x 5.0 x 5.0<br>(34.3 x 12.7 x 12.7) | 7.0<br>(3.2)            | 1/2" NPT          |

Notes: EPCB refers to Extended Pass Carbon Block filter  
(1) All flow rates shown will provide a UV dose of no less than 16,000 mW-s/cm<sup>2</sup> or greater.

## UV ADDON Series™

PURA Product's UV ADDON Series is designed to be an easy addition to water treatment systems that require ultraviolet disinfection (RO systems, holding tanks, water dispensers, recirculating systems and more). The ADDON systems are available with a 1 GPM or 3 GPM flow rate. They are constructed using a 304 grade stainless steel body with a molded head that includes 3/8" quick connect fittings on the inlet/outlet. This versatile system also includes a heavy duty mounting bracket, but will also fit standard 2" RO mounting clips. The UV ADDON Series can be used almost anywhere and is equipped with a unique power supply that makes installation simple, space requirements mini-

### Features:

- ➔ 3/8" quick connect fittings
- ➔ Standard voltage 115V

### Options:

- ➔ 220V/50Hz (2-Prong Euro plug)
- ➔ 12V DC

## Specifications & Performance UV ADDON Series

| Item #   | Model Description | # of sumps | Sump Type | Sump Content | Lamp # | Power Used | Flow Rates <sup>(1)</sup> GPM (L/min) | Dimensions In. (cm) H x W x D         | Shipping Wgt. Lbs. (Kg) | Inlet/Outlet Size |
|----------|-------------------|------------|-----------|--------------|--------|------------|---------------------------------------|---------------------------------------|-------------------------|-------------------|
| 15510100 | UV ADDON-1        | 1          | 304 SS    | UV           | #10    | 10 Watts   | 1 (3.8)                               | 12 x 4 x 3.5<br>(30.5 x 10.2 x 8.9)   | 5.0<br>(2.3)            | 3/8" QC           |
| 15530100 | UV ADDON-3        | 1          | 304 SS    | UV           | #20    | 22 Watts   | 3 (11.4)                              | 22.5 x 4 x 3.5<br>(57.2 x 10.2 x 8.9) | 7.0<br>(3.2)            | 3/8" QC           |



# AQUA FLO

Aqua Flo  
Point-of-Use  
Filtration Products



# Aqua Flo Point-of-Use Water Filters

WaterGroup offers a wide range of point-of-use filtration solutions.

## AQUA FLO

**Aqua Flo Economy** - A full line of quality POU products at a great price point.

**There are two considerations when making a choice of filtration systems:**

- 1) type of housing
- 2) type of Filter Cartridge

### Housings:

Housings come in different sizes, colors, materials of construction and offer different features. Here is a quick breakdown:

- Size - You need to consider the constraints of your install space first but in general the larger the diameter and longer the housing the more flow rate it can handle and higher removal capacity of the cartridge meaning less frequent cartridge changes.
- Color - Housings are usually transparent or opaque. Transparent housings allow for visual inspection when determining to change the cartridges. They are not suitable for outdoor applications however.
- Materials of Construction - Plastic housings are standard for residential applications and temperatures up to 100°F (38°C). Stainless Steel housings, while more expensive, are more durable and can filter higher temperature liquids.
- Features - Some models of plastic housings come with a shut-off valve built into the head of the housing allowing for easier service and installation.



### Cartridges:

There is an overwhelming selection of cartridges to choose from. We have selected a range of cartridges to cover most water quality needs. The two most common applications are for sediment removal and for taste & odor removal (various types of carbon filtration).

A micron rating is also common for most cartridges. One micron is equivalent to 0.000039 inches (the diameter of a human hair is 50 to 70 microns). Choosing the right micron rating is a balance between performance and cartridge life. If you chose a smaller micron rating and the cartridge is loading up too fast then a higher micron rated cartridge may provide a better balance.

# Aqua Flo Filters



The Aqua Flo range of filters and replacement cartridges improves water quality in the home, farm

## \*Carbon Block (CB) Cartridge Filter

The CB cartridge filter is suitable for high capacity chlorine and bad taste and odor reduction from

drinking water. These filters are also used for sediment filtration, making them a great choice for pre-filtering water for reverse osmosis applications. They make an ideal choice for a wide range of residential, food service, commercial and industrial applications.

### Features:

- High Dirt-Holding Tolerance Maximizes Utilization of the Carbon Block
- High porosity maximizes utilization of the carbon block

| Item # | Model #     | Maximum Size | Micron | Capacity (Gallons)     | Flow Rate (gpm) |
|--------|-------------|--------------|--------|------------------------|-----------------|
| 26192  | CCB-1-10*   | 2.5" X 10"   | 1      | 10,000 gallons @ 1 gpm | 1 gpm           |
| 26193  | CCB-5-10*   | 2.5" X 10"   | 5      | 6,000 gallons @ 1 gpm  | 1 gpm           |
| 26194  | CB-0.5-10   | 2.5" X 10"   | 0.5    | 20,000 gallons @ 1 gpm | 1 gpm           |
| 26195  | CB-5-10     | 2.5" X 10"   | 5      | 6,000 gallons @ 1 gpm  | 1 gpm           |
| 26196  | CB-10-10    | 2.5" X 10"   | 10     | 3,000 gallons @ 1 gpm  | 1 gpm           |
| 26197  | CB-0.5-20   | 2.5" X 20"   | 0.5    | 45,000 gallons @ 2 gpm | 2 gpm           |
| 26198  | CB-5-20     | 2.5" X 20"   | 5      | 12,000 gallons @ 2 gpm | 2 gpm           |
| 26199  | CB-10-20    | 2.5" X 20"   | 10     | 6,000 gallons @ 2gpm   | 2 gpm           |
| 26201  | CB-0.5-10BV | 4.5" X 10"   | 0.5    | 50,000 gallons @ 2 gpm | 2 gpm           |
| 26202  | CB-5-10BV   | 4.5" X 10"   | 5      | 22,000 gallons @ 2 gpm | 2 gpm           |
| 26203  | CB-10-10BV  | 4.5" X 10"   | 10     | 15,000 gallons @ 2gpm  | 2 gpm           |
| 26204  | CB-0.5-20BV | 4.5" X 20"   | 0.5    | 150,000 gallons @ 4gpm | 4 gpm           |
| 26205  | CB-5-20BV   | 4.5" X 20"   | 5      | 40,000 gallons @ 4 gpm | 4 gpm           |
| 26206  | CB-10-20BV  | 4.5" X 20"   | 10     | 30,000 gallons @ 4 gpm | 4 gpm           |

## \*Dual Gradient (DG) Density Cartridge Filters

DG cartridge filters are made from 100% polypropylene. The progressively loose structure from inside to outside enhance cartridge performance in reduction of dirt, dust and other particles. The two separate gradient layers of the filter enhances the performance such that it achieves a much higher dirt-loading capacity compared to similar size sediment cartridge filters including spun and string-wound. They make an ideal sediment reduction choice for a wide range of residential, food service, commercial and industrial applications.



### Features:

- No Fiber release and media migration
- Designed for purity, bacteria and chemical resistance
- Two Separate Gradient density layers enhance cartridge performance
- Three times the dirt-holding capacity than other traditional sediment filters

| Item # | Model #       | Maximum Size | Micron | Flow Rate (gpm) |
|--------|---------------|--------------|--------|-----------------|
| 26207  | DG-25-1-10BV  | 4.5" X 10"   | 25/1   | 10 gpm          |
| 26208  | DG-50-5-10BV  | 4.5" X 10"   | 50/5   | 10 gpm          |
| 26209  | DG-75-25-10BV | 4.5" X 10"   | 75/25  | 10 gpm          |
| 26210  | DG-25-1-20BV  | 4.5" X 20"   | 25/1   | 20 gpm          |
| 26211  | DG-50-5-20BV  | 4.5" X 20"   | 50/5   | 20 gpm          |
| 26212  | DG-75-25-20BV | 4.5" X 20"   | 75/25  | 20 gpm          |

## Impregnated Carbon Cellulose (ICC) Dual Purpose Filter

The ICC cartridge filter has a dual benefit for sediment filtration and reduction of chlorine and bad taste and odor from drinking water. These carbon wrap sediment cartridges consists of polypropylene melt blown core with carbon impregnated outer layer wrap. It is an economical solution for general water filtration requirements. This filter has high dirt-loading capacity and is recommended for chlorinated water supplies. These dual-purpose cartridges are well suited for residential applications, and are great polishing filters for closedloop water stream systems. The netting and reinforced support provide strength to the filter.



### Features:

- Provides sediment filtration as well as taste/odor /chlorine reduction
- High dirt loading capacity
- External netting for additional strength

| Item # | Model #     | Maximum Size | Micron | Capacity (Gallons)    | Flow Rate (gpm) |
|--------|-------------|--------------|--------|-----------------------|-----------------|
| 26278  | ICC-5-10    | 2.5" X 10"   | 5      | 2,500 gallons @ 1 gpm | 5 gpm           |
| 26189  | ICC-20-20BV | 4.5" X 20"   | 20     | 7,500 gallons @ 4 gpm | 10 gpm          |

# Aqua Flo Filters



## Pleated Polyester Reusable (PR) Cartridge Filter

PR cartridge filters are made from reusable polyester fibers which are pleated to maximize dirt holding capacity. These cartridge filters are multipurpose.

### Features:

- Pleated design maximizes dirt-holding capacity
- Durable, versatile and reusable
- Polyester media is bacteria and chemical resistant
- Nominal 30-micron rating and nominal 50-micron rating

| Item # | Model #    | Maximum Size | Micron | Capacity (Gallons) | Flow Rate (gpm) |
|--------|------------|--------------|--------|--------------------|-----------------|
| 26242  | PR-30-10BV | 4.5" X 10"   | 30     | 24,000 @ 10.0 gpm  | 10 gpm          |
| 26243  | PR-50-10BV | 4.5" X 10"   | 50     | 24,000 @ 10.0 gpm  | 10 gpm          |
| 26244  | PR-30-20BV | 4.5" X 20"   | 30     | 48,000 @ 10.0 gpm  | 20 gpm          |

## \*Radial Flow (RF) Granular Activated Carbon Cartridge Filters

The RF cartridge filters are the solution for effective reduction of chlorine and bad taste and odor. These filters provide low pressure drop and carbon fines released from the filter are much less compared to the same size GAC style cartridge filter.



### Features:

- Ideal for POE (whole house) and other high flow rate applications
- Unique design reduces carbon fines in filtered water
- Very low pressure drop

| Item # | Model # | Maximum Size | Micron | Capacity (Gallons)     | Flow Rate (gpm) |
|--------|---------|--------------|--------|------------------------|-----------------|
| 26253  | RF-20   | 2.5" X 20"   | N/A    | 6,000 gallons @ 2 gpm  | 4 gpm           |
| 26254  | RF-10   | 2.5" X 10"   | N/A    | 3,000 gallons @ 1 gpm  | 1 gpm           |
| 26255  | RF-10BV | 4.5" X 10"   | N/A    | 35,000 gallons @ 2 gpm | 4 gpm           |
| 26256  | RF-20BV | 4.5" X 20"   | N/A    | 70,000 gallons @ 4 gpm | 8 gpm           |

## \*Spun Poly Bonded (SPB) Cartridge Filters

The SPB filters are manufactured from 100% polypropylene which is resistant to chemical and less prone to bacterial attack. Also they do not impart any taste and odor to the water.



### Features:

- Use on chlorinated or non-chlorinated supplies.
- Designed for purity, bacteria and chemical resistance
- Spun fibers form a true gradient
- Density from outer to inner surfaces

| Item # | Model #  | Maximum Size | Micron | Flow Rate (gpm) |
|--------|----------|--------------|--------|-----------------|
| 26213  | SPB-1-10 | 2.5" X 10"   | 1      | 4 gpm           |
| 26222  | SPB-5-10 | 2.5" X 10"   | 5      | 5 gpm           |
| 26221  | SPB-5-20 | 2.5" X 20"   | 5      | 10 gpm          |

## \*Granular Activated (CGAC) Carbon Cartridge Filter

The CGAC cartridge filters are effective in reduction of chlorine and other bad taste and odor from drinking water.

CGACC cartridge filter contain coconut shell based activated carbon which is an environment friendly but also effective in reducing certain compounds\* better than the coal based granular activated carbon filter cartridges.



### Features:

- Effective taste/odor/ chlorine reduction
- Designed for maximum adsorption
- Post filter to reduce carbon fines

| Item # | Model #   | Maximum Size | Micron                   | Flow Rate (gpm)     |
|--------|-----------|--------------|--------------------------|---------------------|
| 26185  | CGACC-10  | 2.5" X 10"   | 7,500 gallons @ 1 gpm    | 1 gpm @ 7 psi drop  |
| 26277  | CGAC-10   | 2.5" X 10"   | 5,000 gallons @ 1.0 gpm  | 1 gpm @ 7 psi drop  |
| 26186  | CGAC-20   | 2.5" X 20"   | 10,000 gallons @ 2.0 gpm | 2 gpm @ 15 psi drop |
| 26187  | CGAC-BV   | 4.5" X 10"   | 12,500 gallons @ 2.0 gpm | 2 gpm @ 5 psi drop  |
| 26188  | CGAC-20BV | 4.5" X 20"   | 25,000 gallons @ 4.0 gpm | 4 gpm @ 5 psi drop  |



# Aqua Flo Filters



## Polypropylene Melt Blown (PPMB) Filter Cartridges

The PPMB cartridge filters are made by thermally bonding polypropylene microfibers for higher filtration efficiency performance. The polypropylene material is chemical resistant and not prone to bacterial attack. They will also not add any taste, color and odor to the water. They are available in wide variety of sizes and micron ratings.

| Item # | Model #      | Maximum Size | Micron | Flow Rate (gpm) |
|--------|--------------|--------------|--------|-----------------|
| 26269  | PPMB-5-10    | 2.5" X 10"   | 5      | 3 gpm           |
| 26223  | PPMB-10-10   | 2.5" X 10"   | 10     | 4 gpm           |
| 26224  | PPMB-25-10   | 2.5" X 10"   | 25     | 5 gpm           |
| 26225  | PPMB-50-10   | 2.5" X 10"   | 50     | 8 gpm           |
| 26226  | PPMB-1-20    | 2.5" X 20"   | 1      | 4 gpm           |
| 26227  | PPMB-5-20    | 2.5" X 20"   | 5      | 7 gpm           |
| 26228  | PPMB-10-20   | 2.5" X 20"   | 10     | 9 gpm           |
| 26229  | PPMB-25-20   | 2.5" X 20"   | 25     | 11 gpm          |
| 26230  | PPMB-50-20   | 2.5" X 20"   | 50     | 15 gpm          |
| 26231  | PPMB-1-40    | 2.5" X 40"   | 1      | 8 gpm           |
| 26232  | PPMB-5-40    | 2.5" X 40"   | 5      | 14 gpm          |
| 26233  | PPMB-20-40   | 2.5" X 40"   | 20     | 20 gpm          |
| 26234  | PPMB-1-10BV  | 4.5" X 10"   | 1      | 6 gpm           |
| 26235  | PPMB-5-10BV  | 4.5" X 10"   | 5      | 10 gpm          |
| 26236  | PPMB-10-10BV | 4.5" X 10"   | 10     | 11 gpm          |
| 26237  | PPMB-20-10BV | 4.5" X 10"   | 20     | 14 gpm          |
| 26238  | PPMB-1-20BV  | 4.5" X 20"   | 1      | 12 gpm          |
| 26239  | PPMB-5-20BV  | 4.5" X 20"   | 5      | 20 gpm          |
| 26240  | PPMB-10-20BV | 4.5" X 20"   | 10     | 20 gpm          |
| 26241  | PPMB-20-20BV | 4.5" X 20"   | 20     | 20 gpm          |

### Features:

- Constructed from high quality polypropylene filter media for higher filtration efficiency
- Thermally bonded micro-fiber construction for high strength
- Available in micron ratings from 1 to 50 and lengths from 10"- 40

## \*String Wound (SW) Polypropylene Cartridge Filters

SW cartridge filters are manufactured from polypropylene cord which is wound around the polypropylene core. These cartridge filters are economical solution for reduction of sediment, sand, rust and scale particles from the drinking water.

| Item # | Model #  | Maximum Size | Micron | Flow Rate (gpm) |
|--------|----------|--------------|--------|-----------------|
| 26273  | SW-5-10  | 2.5" X 10"   | 5      | 5 gpm           |
| 26246  | SW-10-10 | 2.5" X 10"   | 10     | 7 gpm           |
| 26247  | SW-30-10 | 2.5" X 10"   | 30     | 10 gpm          |
| 26249  | SW-50-10 | 2.5" X 10"   | 50     | 10 gpm          |
| 26250  | SW-1-20  | 2.5" X 20"   | 1      | 15 gpm          |
| 26251  | SW-5-20  | 2.5" X 20"   | 5      | 15 gpm          |
| 26252  | SW-30-10 | 4.5" X 10"   | 30     | 20 gpm          |

### Features:

- String wound filters reduces sediment from a variety of liquids
- Low pressure drop
- Withstand high temperatures
- Wide chemical compatibility



## Pleated Polyester Cartridge (PPC) Filter

The PPC cartridge filters are made from resin impregnated cellulose and polyester fibers. They are constructed with thermally bonded media with end caps and inner core heat sealed together.

### Features:

- Special formulation of resin impregnated cellulose and polyester fibers
- Provides higher wet strength than regular cellulose cartridges
- High flow rate and high dirt holding capacity
- Wide Variety on sizes and micron ranges available

| Item # | Model #     | Maximum Size | Micron | Flow Rate (gpm) |
|--------|-------------|--------------|--------|-----------------|
| 26174  | PPC-1-10    | 2.5" X 10"   | 1      | 5 gpm           |
| 26175  | PPC-5-10    | 2.5" X 10"   | 5      | 7 gpm           |
| 26176  | PPC-1-20    | 2.5" X 20"   | 1      | 10 gpm          |
| 26177  | PPC-5-20    | 2.5" X 20"   | 5      | 13 gpm          |
| 26178  | PPC-5-10BB  | 4.5" X 10"   | 5      | 18 gpm          |
| 26179  | PPC-20-10BB | 4.5" X 10"   | 20     | 20 gpm          |
| 26180  | PPC-5-20BB  | 4.5" X 20"   | 5      | 20 gpm          |
| 26181  | PPC-20-20BB | 4.5" X 20"   | 20     | 35 gpm          |

# Aqua Flo Filters



## Pleated Cellulose (PC) Filter Cartridges

The PC cartridge filters are made from pleated cellulose media and are recommended for general water filtration requirements.

### Features:

- Pleated design maximizes dirt-holding capacity
- Designed for general water filtration purposes
- Nominal 20-micron rating
- Cellulose based material

| Item # | Model #    | Maximum Size | Micron | Flow Rate (gpm) |
|--------|------------|--------------|--------|-----------------|
| 26276  | PC-20-10   | 2.5" X 10"   | 20     | 10 gpm          |
| 26182  | PC-20-20   | 2.5" X 20"   | 20     | 15 gpm          |
| 26183  | PC-20-10BV | 4.5" X 10"   | 20     | 20 gpm          |
| 26184  | PC-20-20BV | 4.5" X 20"   | 20     | 35 gpm          |

# Aqua Flo Filter Housings

Model#s P-H-PR-10-34, P-H-PR-10-34-C/B, P-H-PR-10BV-1, P-H-PR-10BV-34, P-H-PR-B-10-34, P-H-PR-B-10-34-C/BL, P-H-VIH-10-34-C/BL

**NOTE:** This filter housing does NOT include a filter cartridge. Choose the appropriate filter cartridge for your needs and install in housing according to the Cartridge Replacement instructions before proceeding with installation. See cartridge selection chart.

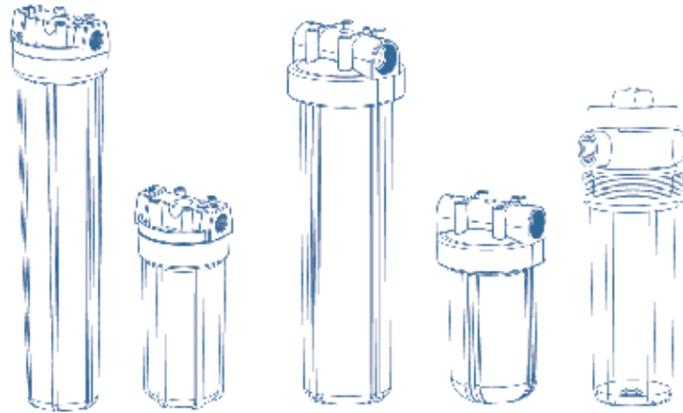

## Specification

### Parts Included:

- ➔ Filter housing
- ➔ Housing wrench
- ➔ Bracket with mounting hardware

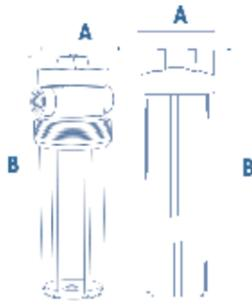

**Tools Required**

- 2 adjustable wrenches
- file
- pipe threader
- 2 pipe wrenches
- pencil
- pipe cutter or hacksaw

**Materials Required (not included)**  
Depends on type, size, and location of pipe on which filter will be installed. Measure the pipe to determine what size nipples, union, and valve you will need. Depending on the pipe size, you will also need to purchase the appropriate size fittings. Consult your local hardware store to learn more about your particular installation needs.

**NOTE:** Galvanized fittings must be used with galvanized pipe.

**Optional Materials**

- jumper wire

## Filter Housing Specifications

| Category          | Part # | Model #             | Housing Material                  | Housing O-Ring Material | Size          | In/Out | Temperature Range (Deg F) | Operating Pressure Range (psi) | City Water/Well Water |
|-------------------|--------|---------------------|-----------------------------------|-------------------------|---------------|--------|---------------------------|--------------------------------|-----------------------|
| Housing (w/PR)    | 26051  | P-H-PR-10-34        | Polypropylene (blue) & AS (clear) | EPDM                    | 2.5"X10"      | 3/4"   | 40 to 140                 | 30-100                         | Both                  |
| Housing (w/PR)    | 26052  | P-H-PR-10-34-C/BL   | Polypropylene (blue) & AS (clear) | EPDM                    | 2.5"X10"      | 3/4"   | 40 to 140                 | 30-100                         | Both                  |
| Housing (w/PR)    | 26053  | P-H-PR-10BV-1       | Polypropylene (blue) & AS (clear) | EPDM                    | 4.5"X10"      | 1"     | 40 to 140                 | 30-100                         | Both                  |
| Housing (w/PR)    | 26055  | P-H-PR-10BV-34      | Polypropylene (blue) & AS (clear) | EPDM                    | 4.5"X10"      | 3/4"   | 40 to 140                 | 30-100                         | Both                  |
| Housing (w/PR)-3G | 26056  | P-H-PR-B-10-34      | Polypropylene (blue) & AS (clear) | EPDM                    | 2.5"X10" (3G) | 3/4"   | 40 to 140                 | 30-100                         | Both                  |
| Housing (w/PR)-3G | 26058  | P-H-PR-B-10-34-C/BL | Polypropylene (blue) & AS (clear) | EPDM                    | 2.5"X10" (3G) | 3/4"   | 40 to 140                 | 30-100                         | Both                  |
| Housing -VIH/PR   | 26060  | P-H-VIH-10-34-C/BL  | Polypropylene (blue) & AS (clear) | EPDM                    | 2.5"X10"      | 3/4"   | 40 to 140                 | 30-100                         | Both                  |

\*SS = stainless steel threads

# Aqua Flo Filter Housings

| Cartridge Selection (For Filter Housing Model # H-PR-10BV-34 and H-PR-10BV-1) |                            |   |                                       |
|---|----------------------------|---|---------------------------------------|
| Select the Cartridge Filter for your water needs                              | PR-50-10BV (Part# 26243)   | PPC-5-10BV (Part# 26178)                | RF-10BV (Part# 26255)                 |
| <b>Filter Type</b>  | Pleated Polyester Reusable | Pleated Cellulose Cartridge - Polyester | Radial Flow Granular Activated Carbon |
| <b>Scale and Rust Particles</b>   | X                          | X                                       |                                       |
| <b>Coarse Sand</b>  | X                          | X                                       |                                       |
| <b>Sand/Dirt/Silt</b>   |                            | X                                       |                                       |
| <b>Fine Dirt/Silt/Sand</b>  |                            | X                                       |                                       |
| <b>Extra Fine Dirt/Silt/Sand</b>  |                            | X                                       |                                       |
| <b>Bad Taste &amp; Odor</b>   |                            |   | X                                     |
| <b>Aesthetic Chlorine: Taste &amp; Odor</b>                                   |                            |   | X                                     |
| <b>Filter Life (in months)*</b>   | 6                          | 6                                       | 6                                     |
| <b>Micron Rating (Nominal) +</b>  | 50                         | 5                                       |                                       |
| <b>Service Flow Rate gpm (lpm)**</b>  | 10 (37)                    | 18 (66)                                 | 4(15)                                 |

\*NOTE: Filter cartridge life varies depending on usage and water conditions

\*\*NOTE: Flow rates measured at 60 psi (4.1 bar)

The smaller the micron rating, the smaller the size particle the cartridge will filter. For comparison purposes, the human hair has a diameter of approximately 70 microns. Particles smaller than 40 microns are not visible with the human eye.

| Cartridge Selection (For Filter Housing Model # H-PR-20BV-34, H-PR-20BV-1 & H-PR-20BV-15) |                            |   |                                       |
|---|----------------------------|---|---------------------------------------|
| Select the Cartridge Filter for your water needs  | PR-30-20BV (Part# 26244)   | PPC-5-20BV (Part# 26180)                | RF-20BV (Part# 26256)                 |
| <b>Filter Type</b>  | Pleated Polyester Reusable | Pleated Cellulose Cartridge - Polyester | Radial Flow Granular Activated Carbon |
| <b>Scale and Rust Particles</b>   | X                          | X                                       |                                       |
| <b>Coarse Sand</b>  | X                          | X                                       |                                       |
| <b>Sand/Dirt/Silt</b>   |                            | X                                       |                                       |
| <b>Fine Dirt/Silt/Sand</b>  |                            | X                                       |                                       |
| <b>Extra Fine Dirt/Silt/Sand</b>  |                            | X                                       |                                       |
| <b>Bad Taste &amp; Odor</b>   |                            |   | X                                     |
| <b>Aesthetic Chlorine: Taste &amp; Odor</b>   |                            |   | X                                     |
| <b>Filter Life (in months)*</b>   | 6                          | 6                                       | 6                                     |
| <b>Micron Rating (Nominal) +</b>  | 30                         | 5                                       |                                       |
| <b>Service Flow Rate gpm (lpm)**</b>  | 20 (76)                    | 20 (76)                                 | 4 (15)                                |

\*NOTE: Filter cartridge life varies depending on usage and water conditions

\*\*NOTE: Flow rates measured at 60 psi (4.1 bar)

The smaller the micron rating, the smaller the size particle the cartridge will filter. For comparison purposes, the human hair has a diameter of approximately 70 microns. Particles smaller than 40 microns are not visible with the human eye.

# Aqua Flo Filter Housings

| Cartridge Selection (For Filter Housing Model # H-PR-10-34, WCT34SS & WVIH34SS) Cartridge Filter Size 2.5" X 10" |   |                                       |                             |                            |                                 |                                |                                |   |                        |                        |
|--|---|---------------------------------------|-----------------------------|----------------------------|---------------------------------|--------------------------------|--------------------------------|---|------------------------|------------------------|
| Select the Cartridge Filter for your water needs   | PPC-5-10 (Part# 26175)                  | RF-10 (Part# 26254)                   | PC-20-10 (Part# 26276)      | SW-10-10 (Part# 26246)     | WSW30 or SW-30-10 (Part# 26247) | WSW05 or SW-5-10 (Part# 26273) | WC-10 or CGAC-10 (Part# 26277) | WT10 or ICC-5-10 (Part # 26278)             | SPB-5-10 (Part# 26222) | SPB-1-10 (Part# 26213) |
| <b>Filter Type</b>   | Pleated Cellulose Cartridge - Polyester | Radial Flow Granular Activated Carbon | Pleated Cellulose Cartridge | String Wound Polypropylene | String Wound Polypropylene      | String Wound Polypropylene     | Granular Activated Carbon      | Dual Purpose - Carbon Impregnated Cellulose | Spun Poly Bonded       | Spun Poly Bonded       |
| <b>Scale and Rust Particles</b>  | X                                       |                                       | X                           | X                          | X                               | X                              |                                | X   | X                      | X                      |
| <b>Coarse Sand</b>   | X                                       |                                       | X                           | X                          | X                               | X                              |                                | X   | X                      | X                      |
| <b>Sand/Dirt/Silt</b>  | X                                       |                                       | X                           | X                          | X                               | X                              |                                | X   | X                      | X                      |
| <b>Fine Dirt/Silt/Sand</b>   | X                                       |                                       |                             | X                          |                                 | X                              |                                | X   | X                      | X                      |
| <b>Extra Fine Dirt/Silt/Sand</b>   | X                                       |                                       |                             |                            |                                 | X                              |                                | X   | X                      | X                      |
| <b>Bad Taste &amp; Odor</b>  |   | X                                     |                             |                            |                                 |                                | X                              | X   |                        |                        |
| <b>Aesthetic Chlorine: Taste &amp; Odor</b>  |   | X                                     |                             |                            |                                 |                                | X                              | X   |                        |                        |
| <b>Filter Life (in months)*</b>  | 6                                       | 6                                     | 6                           | 6                          | 6                               | 6                              | 6                              | 6   | 6                      | 6                      |
| <b>Micron Rating (Nominal) +</b>   | 5                                       |                                       | 20                          | 10                         | 30                              | 5                              | -                              | 5   | 5                      | 5                      |
| <b>Service Flow Rate gpm (lpm)**</b>   | 5 (26)                                  | 1 (3.7)                               | 10 (37)                     | 7 (26)                     | 10 (37)                         | 5 (18)                         |                                |   | 5 (5.6)                | 4 (5.6)                |

\*NOTE: Filter cartridge life varies depending on usage and water conditions

\*\*NOTE: Flow rates measured at 60 psi (4.1 bar)

The smaller the micron rating, the smaller the size particle the cartridge will filter. For comparison purposes, the human hair has a diameter of approximately 70 microns. Particles smaller than 40 microns are not visible with the human eye.

| Cartridge Selection (For Filter Housing Model # H-PR-20-34) |   |                                       |                             |                        |
|---|---|---------------------------------------|-----------------------------|------------------------|
| Select the Cartridge Filter for your water needs            | PPC-5-20 (Part# 26177)                  | RF-20 (Part# 26253)                   | PC-20-20 (Part# 26182)      | SPB-5-20 (Part# 26221) |
| <b>Filter Type</b>  | Pleated Cellulose Cartridge - Polyester | Radial Flow Granular Activated Carbon | Pleated Cellulose Cartridge | Spun Poly Bonded       |
| <b>Scale and Rust Particles</b>                             | X                                       |                                       | X                           | X                      |
| <b>Coarse Sand</b>  | X                                       |                                       | X                           | X                      |
| <b>Sand/Dirt/Silt</b>                                       | X                                       |                                       | X                           | X                      |
| <b>Fine Dirt/Silt/Sand</b>                                  | X                                       |                                       |                             | X                      |
| <b>Extra Fine Dirt/Silt/Sand</b>                            | X                                       |                                       |                             | X                      |
| <b>Bad Taste &amp; Odor</b>                                 |   | X                                     |                             |                        |
| <b>Aesthetic Chlorine: Taste &amp; Odor</b>                 |   | X                                     |                             |                        |
| <b>Filter Life (in months)*</b>                             | 6                                       | 6                                     | 6                           | 6                      |
| <b>Micron Rating (Nominal) +</b>                            | 5                                       |                                       | 20                          | 5                      |
| <b>Service Flow Rate gpm (lpm)**</b>                        | 13 (49)                                 | 4 (15)                                | 15 (55)                     | 10 (37)                |

\*NOTE: Filter cartridge life varies depending on usage and water conditions

\*\*NOTE: Flow rates measured at 60 psi (4.1 bar)

The smaller the micron rating, the smaller the size particle the cartridge will filter. For comparison purposes, the human hair has a diameter of approximately 70 microns. Particles smaller than 40 microns are not visible with the human eye.

# Aqua Flo Filter Accessories

## 26007 Sump Wrench (new style)

Wrench with six notches. Fits AquaFlo sumps manufactured since January 1993.

## 92289 Sump Wrench (old style)

Wrench with four notches. Fits Aqua Flo sumps manufactured prior to 1993.



## 26023 Mounting Bracket

Convenient bracket with eight screws for mounting the WC34 filter.



## 26049 Aqua Flo Sump and O-Ring

Convenient bracket with eight screws for mounting the WC34 filter.

## 26022 O-Ring

Buna O-ring seals filter sump and head.



# Stainless Steel Housings



## Features:

- ➔ Low cost alternative to RO heavy-duty units for smaller filtration systems and point-of-use applications
- ➔ Brushed 304 stainless steel sump with a cast brass / nickel plated head
- ➔ Ideal for high-pressure / hot water applications
- ➔ Utilizes double open-end cartridges

## Materials of Construction

|                 |                             |
|-----------------|-----------------------------|
| Housing         | Brushed 304 Stainless Steel |
| Head            | Brass / Nickel Plated       |
| Max Temperature | 300°F (149°C)               |
| Pipe Size       | 3/4" NPT                    |
| Sealing Gaskets | Buna-N, Cellulose Fiber     |

| Category            | Part# | Model #    | Size             | Temperature Range (Deg F) | Operating Pressure Range (psi) | City Water/Well Water |
|---------------------|-------|------------|------------------|---------------------------|--------------------------------|-----------------------|
| Housing - SS        | 36146 | P-SS-1     | 2.5"X10"         | 32 to 206.6               | 0 to 300                       | Both                  |
| Housing - SS        | 36147 | P-SS-2     | 2.5"X20"         | 32 to 206.6               | 0 to 300                       | Both                  |
| Housing - SS        | 36148 | P-SS-3     | 2.5"X30"         | 32 to 206.6               | 0 to 300                       | Both                  |
| Housing - SS        | 36145 | P-SS-SF    | 2.5"X10"         | 32 to 206.6               | 0 to 300                       | Both                  |
| Housing - SS - STBC | 36219 | P-SS-BC-12 | 12-10" or 4-30"  | 32 to 206.6               | 0 to 300                       | Both                  |
| Housing - SS - STBC | 36220 | P-SS-BC-16 | 16-10" or 4-40"  | 32 to 206.6               | 0 to 300                       | Both                  |
| Housing - SS - STBC | 36221 | P-SS-BC-20 | 20-10" or 5-40"  | 32 to 206.6               | 0 to 300                       | Both                  |
| Housing - SS - STBC | 36222 | P-SS-BC-4  | 4-10"            | 32 to 206.6               | 0 to 300                       | Both                  |
| Housing - SS - STBC | 36223 | P-SS-BC-8  | 8-10" or 4 - 20" | 32 to 206.6               | 0 to 300                       | Both                  |

## #65020053 Side Stream Filter Assembly

Pre-Assembled SS-1 Housing with stainless steel shutoffs and stainless steel flow indicator.

Side stream filters are primarily used for filtering a portion of the water in a closed loop boiler system to protect the boiler, controls and circulating pumps

Dimensions: 14 1/8" (h) x 20 3/4" (w) x 4 1/8" (d)



Chemical Feed Pumps  
Pro Chemicals  
Test Kits  
Mazzei Injectors  
John Guest Fittings



# Chemical Feed Pumps

## 45 Pump Series Single Head Adjustable Rate

### How it Works

Stenner's adjustable metering pump is built with three detachable components: the motor, feed rate control and pump head. Outputs are dependent upon three factors: the rpm of the motor gears, the percentage setting on the feed rate control and the size of the peristaltic pump tube. All Stenner metering pumps have a 3-point roller design in the pump head, which acts as a check valve to prevent back flow, siphoning, overdosing and loss of prime.

The motor shaft rotates at a fixed rpm which drives the adjustable feed rate control to intermittently engage the roller assembly within the pump head. The chemical solution in the pump tube is captured between the rollers as they rotate and compress the tube. As the rollers advance, the squeezed tube section regains its original form and generates a vacuum, creating the self-priming feature that delivers a constant flow unaffected by the outlet pressure.

### Advantages:

- ➔ Self-priming up to 25 feet does not lose prime
- ➔ Can pump off-gassing solutions
- ➔ Solutions contained in tube, not exposed to pump components or air
- ➔ Sub-assemblies fit together without tools, easy service or conversion to another model
- ➔ Pump head universal to all Stenner pumps
- ➔ Can run dry without damage
- ➔ Will not clog from dirt or debris
- ➔ Reproducible outputs within 2%
- ➔ Adjustable feed rate control from 5% - 100% in 2.5% increments
- ➔ Pump tubes accept a variety of chemical
- ➔ 1 Year Guarantee from date of manufacture



**STENNER PUMPS**

*the patented mechanical feed rate control allows the pump's output to be scaled from 5% to 100% with the simple turn of the dial.*

# Chemical Feed Pumps

### 45MHP2

100 psi (6.9 bar)  
max 3 gpd (11 lpd)

### Outputs @ 60Hz

Gallons per day: 0.2 to 3.0  
Gallons per hour: 0.01 to 0.13  
Liters per day: 0.8 to 11.4  
Liters per hour: 0.03 to 0.48  
Ounces per minute: 0.02 to 0.27  
Milliliter per minute: 0.56 to 7.92

### Outputs @ 50Hz

Liters per day: 0.6 to 9.1  
Liters per hour: 0.03 to 0.38  
Milliliters per minute: 0.31 to 6.32

### Maximum Operating Temperature

12° F (52° C)

### Amp Draw

1.7 120V; 0.9 220V, 230V, 250V

### Dimensions (l x w x h)

10.6 x 5.3 x 6.0 in  
(26.9 x 13.4 x 15.2 cm)

### Shipping Weight

9 lbs (4 kg)

### 45MHP10

100 psi (6.9 bar)  
10 gpd (38 lpd)

### Outputs @ 60Hz

Gallons per day: 0.5 to 10.0  
Gallons per hour: 0.02 to 0.42  
Liters per day: 1.9 to 37.9  
Liters per hour: 0.08 to 1.58  
Ounces per minute: 0.04 to 0.89  
Milliliter per minute: 1.32 to 26.32

### Outputs @ 50Hz

Liters per day: 1.5 to 30.3  
Liters per hour: 0.06 to 1.26  
Milliliters per minute: 1.04 to 21.04

### Discharge Pressure

26-100 psi (1.7-6.9 bar)

### Voltage

120V 60Hz; 220V 60Hz  
230V 50Hz; 250V 50Hz International

### Motor

shaded pole; 26 rpm; 1/30 HP

### Suction Lift

25' (7.6 m)

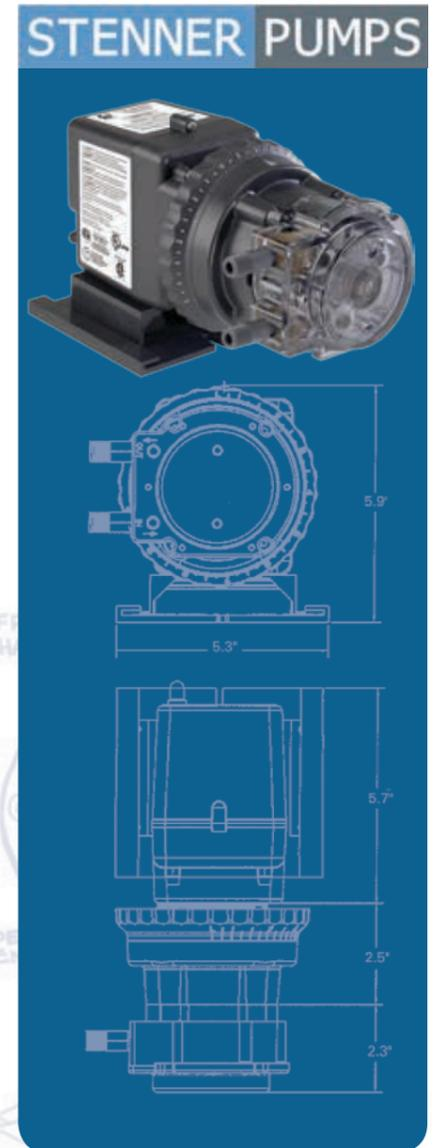

| Item # |       | Model   | Tube | Feed Rate Setting: Outputs per day in US Gallons @ 60Hz |     |     |     |     |     |     |     |     |     |    |
|--------|-------|---------|------|---|-----|-----|-----|-----|-----|-----|-----|-----|-----|----|
| CDN #  | US #  |         |      | L   | 1   | 2   | 3   | 4   | 5   | 6   | 7   | 8   | 9   | 10 |
| 11873  | 11873 | 45MHP2  | #1   | 0.2   | 0.3 | 0.6 | 0.9 | 1.2 | 1.5 | 1.8 | 2.1 | 2.4 | 2.7 | 3  |
| 11874  | 11810 |         |      | 0.5   | 1   | 2   | 3   | 4   | 5   | 6   | 7   | 8   | 9   | 10 |
| 11876  | 11809 | 45MHP10 | #2   | 0.5   | 1   | 2   | 3   | 4   | 5   | 6   | 7   | 8   | 9   | 10 |
| 11879  | 11808 |         |      |   |     |     |     |     |     |     |     |     |     |    |

| Item # | Description             |
|--------|-------------------------|
| 11873  | 45MHP2-110v, ¼" tubing  |
| 11874  | 45MHP2-220v, ¼" tubing  |
| 11876  | 45MHP10-110v, ¼" tubing |
| 11879  | 45MHP10-220v, ¼" tubing |

# Chemical Feed Pumps

## 85 Pump Series Single Head Adjustable Rate

### How it Works

Stenner's fixed output metering pump is built with two detachable components: the motor and pump head. Outputs are dependent upon the rpm of the motor gears and the size of the peristaltic pump tube.

The fixed rate pump has no output adjustment. All Stenner metering pumps have a 3-point roller design in the pump head, which acts as a check valve to prevent back flow, siphoning, overdosing and loss of prime.

The motor's output shaft rotates at a fixed rpm which drives the roller assembly within the pump head. The chemical solution in the pump tube is captured between the rollers as they rotate and compress the tube. As the rollers advance, the squeezed tube section regains its original form and generates a vacuum, creating the self-priming feature that delivers a constant flow unaffected by the outlet pressure.

### Advantages:

- ➔ Self-priming up to 25 feet and does not lose prime
- ➔ Can pump off-gassing solutions
- ➔ Solutions contained in tube, not exposed to pump components or air
- ➔ Subassemblies fit together without tools; easy service or conversion to another model
- ➔ Pump head universal to all Stenner pumps
- ➔ Can run dry without damage
- ➔ Will not clog from dirt or debris
- ➔ Reproducible outputs within 2%
- ➔ Adjustable feed rate control from 5%-100% in 2.5% increments
- ➔ Pump tubes accept a variety of chemicals

### Outputs @ 60Hz

Gallons per day: 0.8 to 17.0  
 Gallons per hour: 0.03 to 0.71  
 Liters per day: 3.0 to 64.4  
 Liters per hour: 0.13 to 2.68  
 Ounces per minute: 0.07 to 1.51  
 Milliliter per minute: 2.08 to 44.65

### Outputs @ 50Hz

Liters per day: 2.4 to 51.5  
 Liters per hour: 0.10 to 2.15  
 Milliliters per minute: 1.67 to 35.76

### Discharge Pressure

26-100 psi (1.7-6.9 bar)

### Voltage

Voltage 120V 60Hz; 220V 60Hz/230V 50Hz; 250V 50Hz International

### Motor

shaded pole; 44 rpm;  
 1/30 HP

### Suction Lift

25' (7.6 m)

### Maximum Operating Temperature

125° F (52° C)

### Amp Draw

1.7 120V; 0.9 220V, 230V, 250V

### Dimensions (l x w x h)

10.6 x 5.3 x 6.0 in  
 (26.9 x 13.4 x 15.2 cm)

### Shipping Weight

9 lbs (4 kg)



STENNER PUMPS

# Chemical Feed Pumps

### Materials of Construction

All Housings: Lexan® polycarbonate plastic  
 Pump tube & check valve duckbill: Santoprene® FDA approved

Pump tube: Tygothane® FDA approved

Checkvalve duckbill (w/Tygothane tube): Pellathane®

Suction/discharge tubing & ferrules (1/4" & 6 mm):

LDPE polyethylene,

NSF/FDA approved

Tube fittings, connecting nuts, check valve fitting,

weighted strainer: Type 1 Rigid PVC-NSF listed

All fasteners: Stainless Steel

Lexan® is a registered trademark of General Electric.

Santoprene® is a registered trademark of Advanced

Elastomer system

Tygothane® is a registered trademark of Saint-Gobain

Performance Plastics

Pellathane® is a registered trademark of The Dow

Company

### Agency listings

Santoprene®: UL, CSA, CE, NSF-50, NSF-61

Tygothane®: UL, CSA, CE

### Accessories shipped with each pump

3 connecting nuts 1/4" or 3/8"

3 ferrules 1/4" & 6 mm or 2 ferrules 3/8"

1 injection check valve

1 weighted strainer

1 20' roll of suction/discharge tubing 1/4" or 3/8" white or UV

black or 6 mm (Europe) white

1 spare pump tube

1 mounting bracket

1 installation manual

STENNER PUMPS



| Item # | Model | Tube      | Feed Rate Setting: Outputs per day in US Gallons @ 60Hz |     |     |     |     |     |     |     |     |     |     |  |
|--------|-------|-----------|---|-----|-----|-----|-----|-----|-----|-----|-----|-----|-----|--|
| CDN #  | US #  |           | L   | 1   | 2   | 3   | 4   | 5   | 6   | 7   | 8   | 9   | 10  |  |
| 11880  | 11852 | 85MHP5 #1 | 0.3   | 0.5 | 1.0 | 1.5 | 2.0 | 2.5 | 3.0 | 3.5 | 4.0 | 4.5 | 5.0 |  |
| 11872  | 11853 |           |   |     |     |     |     |     |     |     |     |     |     |  |

| Item # | Description             |
|--------|-------------------------|
| 11880  | STENNER-PUMP-85MHP5-110 |
| 11872  | STENNER-PUMP-85MHP5-220 |

PARTIAL HOLE IS BROKEN THROUGH WITH PHILLIPS HEAD #2 SCREWDRIVER.  
 PLASTIC SPILL RECOVERY TUBE IS INSERTED IN HOLE.

# Flow Switch (Low Flow Rate – SPDT)

## Description:

For use on liquid lines using water, ethylene glycol solutions, or other liquids not corrosive to the brass or phosphor bronze parts. The SPDT contact switch is activated by a low flow rate; however, it has a large flow capacity with a minimum pressure drop.

## Applications:

- ➔ Water purification and treatment systems
- ➔ Booster pumps
- ➔ Fast shutdown on high input boilers to guard against circulation failure
- ➔ Cooling systems for electronic tubes, bearings, and compressors

F61KD-4



| Item #   | Description                                 | Inlet and Outlet Size Female NPT | Enclosure NEMA Type | Adjustment Range - GPM (L/Min)   |                                 | Maximum Liquid Temp | Minimum Liquid Temp | Maximum Liquid Pressure |
|----------|---|----------------------------------|---------------------|----------------------------------|---------------------------------|---------------------|---------------------|-------------------------|
|          |   |                                  |                     | R to Y Closes Flow Increase      | R to Y Opens Flow Decrease      |                     |                     |                         |
| 99000070 | F61KD-4C Flow Switch (Low Flow Rate - SPDT) | 3/4" x 3/4" (19mm x 19mm)        | 1                   | Min 0.6 (2.27)<br>Max 1.1 (4.17) | Min 0.3 (1.14)<br>Max 0.9 (3.4) | 250°F (121°C)       | 32°F (0°C)          | 150 psig (1034 kPa)     |

| Dimensions                    |  |
|-------------------------------|--|
| 5 1/32" h x 4" w x 2 13/16" d |  |
| 127mm x 102mm x 71mm          |  |

| Electrical                         | 120 VAC            |
|------------------------------------|--------------------|
| Horsepower                         | 1                  |
| AC Full Load A                     | 16                 |
| AC Locked Rotor A                  | 96                 |
| Non-Inductive or Resistance Load A | 16                 |
| Pilot Duty                         | 125 VA, 24/277 VAC |

# Pulsafeeder Kopkit



## Kopkit®

Available for every model, the KOPkit provides an economically priced package of parts required for routine maintenance. The kit typically contains new valve cartridges with o-rings, head, diaphragm, secondary o-ring seal, head screws and washers.

# Stenner Pump Control Module

## How It Works:

The Pump Control Module (PCM) is a component of the proportional feed system, which delivers repeatable doses regardless of the system's flow rate. The system is used in applications requiring proportional chemical injection.

The proportional feed system, Stenner refers to as the PCM system consists of three components:

- ➔ PCM – pump control module
- ➔ Single head fixed output pump (45 or 85 model)
- ➔ Dry contact water meter

The water meter sends a pulse signal to the PCM which activates the pump to deliver the desired dose based on water volume. The PCM turns on the pump for the set duration determined to inject the solution into the water line.

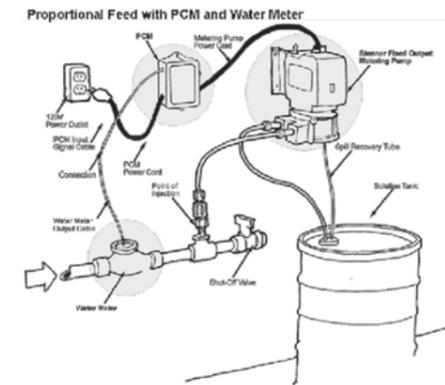

# Water Meters

## Features:

- ➔ Reed switch
- ➔ Dry contact
- ➔ Power not required

## Material:

- ➔ Body: Cast bronze
- ➔ Internal: Engineered thermoplastic
- ➔ Magnet: Alnico

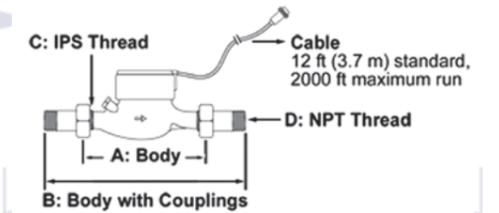

| Size   | A Body            | B Body w Couplings | C IPS Thread    | D NPT Thread    |
|--------|-------------------|--------------------|-----------------|-----------------|
| 3/4"   | 7 1/2" (19.1 cm)  | 12 5/8" (32.1 cm)  | 1" (2.5 cm)     | 3/4" (1.9 cm)   |
| 1"     | 10 1/4" (26.0 cm) | 15 5/8" (36.7 cm)  | 1 1/4" (3.2 cm) | 1" (2.5 cm)     |
| 1 1/2" | 11 3/4" (29.9 cm) | 17 5/8" (44.8 cm)  | 2" (5.1 cm)     | 1 1/2" (3.8 cm) |
| 2"     | 11 3/4" (29.9 cm) | 17 5/8" (44.8 cm)  | 2 1/2" (6.4 cm) | 2" (5.1 cm)     |

| Water Meters |   | Min Flow             | Max Flow | Max Operating Temp | Max Operating Pressure |
|--------------|---|----------------------|----------|--------------------|------------------------|
| Item #       | Description   | (Gallons Per Minute) |          |                    |                        |
| 80060050     | Meter, Contacting Stenner WM0751G 3/4" 1Gallon/Pulse      | 0.22                 | 22       | 105 F (40 C)       | 150 psi                |
| 80060051     | Meter, Contacting Stenner WM1001G 1" 1Gallon/Pulse        | 0.44                 | 52       | 105 F (40 C)       | 150 psi                |
| 80060052     | Meter, Contacting, 1.5" 1.0 GPC, 404(Gal/Contact)         | 0.88                 | 88       | 105 F (40 C)       | 150 psi                |
| 80060053     | Meter, Contacting, 2.0" 1.0 GPC, 504(Gal/Contact)         | 1.98                 | 132      | 105 F (40 C)       | 150 psi                |
| 27399        | Timer, Stenner, Pump Control Module 5, 0.5 to 5.0 seconds |                      |          |                    |                        |

# Retention Tanks

Made from a unique 3 piece internal construction that allows for consistent engineered dome profiles and integrally bonded connections that lead to longer tank life. Its heavy duty base is molded out of ABS for maximum strength and durability. And, It has a removable schedule 80 PVC bottom connection that can be "accessorized" for increased installation flexibility.

- ➔ Durable PVC water connection.
- ➔ Flexwave tanks are made in the USA and built to comply with NSF/ANSI Std 61
- ➔ 5 year warranty



## FWC Contact Retention Tanks - Dimensions & Capacities

| Model     | Item #  | Total Tank Volume |        | Height |       | Diameter |      | Socket Glue Connection | FPT    | Total Weight |       |
|-----------|---------|-------------------|--------|--------|-------|----------|------|------------------------|--------|--------------|-------|
|           |         | Gallons           | Litres | In     | Cm    | In       | Cm   |                        |        | Lbs          | Kilos |
| FWC 30    | 33201-1 | 30                | 114    | 42.5   | 108   | 16.5     | 41.8 | 1 1/4"schd-80          | 1 1/4" | 23.0         | 10.4  |
| FWC 40    | 33202-1 | 40                | 151    | 53.4   | 135.6 | 16.5     | 41.8 | 1 1/4"schd-80          | 1 1/4" | 31.0         | 14.1  |
| FWC 40 SQ | 33203-1 | 40                | 151    | 36.9   | 93.8  | 21.4     | 54.2 | 1 1/4"schd-80          | 1 1/4" | 33.1         | 15.0  |
| FWC 80    | 33204-1 | 80                | 303    | 64.1   | 162.8 | 21.4     | 54.2 | 1 1/4"schd-80          | 1 1/4" | 60.0         | 27.0  |
| FWC 120   | 33205-1 | 120               | 454    | 71.5   | 181.6 | 24.2     | 61.4 | 1 1/4"schd-80          | 1 1/4" | 83.5         | 38.0  |

Maximum working temperature, internal & external 120F. Materials of Construction: Tank top and bottom domes injection molded copolymer polypropylene. Shell extruded polypropylene. Outer shell composite construction with fiberglass coated with epoxy resin. Base is injection molded ABS. Top and side ports are stainless steel reinforced.

## BAF Mixing Tank - Dimensions & Capacities

| Model   | Item # | Total Tank Volume |        | Height |     | Diameter |      | Thread Connection | Outlet Connection at top of tank | Total Weight |       |
|---------|--------|-------------------|--------|--------|-----|----------|------|-------------------|----------------------------------|--------------|-------|
|         |        | Gallons           | Litres | In     | Cm  | In       | Cm   |                   |                                  | Lbs          | Kilos |
| BAF 80  | 33217  | 80                | 303    | 64.1   | 163 | 21.4     | 54.4 | 1 1/4"NPT         | 1 1/4" FPT                       | 23.0         | 10.4  |
| BAF 120 | 33211  | 119               | 450    | 71.5   | 182 | 21.4     | 54.4 | 1 1/4"NPT         | 1 1/4" FPT                       | 31.0         | 14.1  |

Maximum working pressure 100 PSI. Maximum working temperature, internal & external 120F. Materials of Construction: Copolymer polypropylene wrapped with fiberglass coated with epoxy resin. Base is rigid ABS. Inner baffle is a copolymer polypropylene with a PVC sch 40 standpipe and diffuser cap. Top port is stainless steel reinforced and bottom connections are a 1 1/4" NPT schedule 80- connection

# Mixing Tanks



The Mixmaster(BAF) Series tanks are a retention tank with an internal baffle and diffuser which improves mixing and increases the retention time improving the effectiveness of chemical treatment of water for disinfection or mineral removal. Great for killing bacteria or for agricultural applications.

- ➔ Polypropylene tank reinforced with fiberglass sealed with epoxy resin.
- ➔ Cross- link polyethylene upper and lower water chamber. Standpipe and diffuser 1-1/4"pvc sch 40

# Chemicals



## Sani-System Liquid Sanitizer Concentrate

Sani-System is the only EPA & NSF approved sanitizer for use in water softeners and reverse osmosis units. It's proven to kill 99.99% of harmful bacteria without the use of chlorine, oxidizers or acids that can harm system equipment parts and resin. The exact pre-measured doses of concentrated

### Simple to Use:

For water softeners it is as simple as pouring into the brine well or brine tank and manually regenerating the unit. For reverse osmosis units, simply remove the cartridges and place the packet contents in the first housing and flush. Sani-System is the only sanitizer on the market proven by the WQA to safely sanitize an RO unit membrane.

### User Benefits:

- ➔ Faster, easier and safer than other alternative sanitizers
- ➔ Easy & reliable single dose packages
- ➔ 99.99% effective kill rate against harmful bacteria
- ➔ Only sanitizer on market proven by WQA to sanitize membrane

### Technical Information:

- ➔ Sani-System is a clear liquid and will react to oxidizers
- ➔ Routine storage. Rubber gloves are suggested when handling. Read all relevant MSDS before handling.
- ➔ Do not mix with other chemicals
- ➔ Certified to NSF/ANSI 60 Standards

| Item # | Description   |
|--------|---|
| 50035  | Sani-System RO Sanitizer 0.25 fl.oz (24 Packets)            |
| 50032  | Sani-System Water Softener Sanitizer 0.5 fl.oz (24 Packets) |



# Chemicals

## Pro Chemicals

Pro Chemicals provides a diverse portfolio of water softener cleaners designed to clean, restore and maintain the life of water softeners. These products are formulated to treat water softeners with iron or for daily preventative maintenance.

### Rust Out® Water softener Cleaner/iron remover

Rust Out® chemically removes iron and rust build-up that coats the resin bead and fouls the water softener. Rust Out changes rust and iron into a clear solution that easily rinses away and does not contain harsh or abrasive chemicals that damage fiberglass, porcelain or acrylic finishes. The advanced formula contains more than five chemicals that are formulated to clean, restore and maintain the life of water softeners. Rust Out can also be used to clean tough rust stains from toilets, sinks, tubs, white clothes and exterior surfaces.



| Item # | Description               |
|--------|---------------------------|
| 45126  | Rust Out - 1.5 lb. Bottle |
| 45127  | Rust Out - 5 lb. Bottle   |
| 45128  | Rust Out - 50 lb Pail     |

### Res Care® liquid Resin Cleaning Solution

Res Care® is a specially formulated liquid cleaner designed to remove limited iron, manganese, silt, metal particles and organic compounds that cause softener inefficiencies. Regular use of Res Care will restore the softener back to peak efficiency and maintain the life of the unit. For best results use a Res Care Automatic Feeder or manually add during regeneration to prevent mineral build-up.



| Item #   | Description                                  |
|----------|--|
| 45147    | Res Care - 1 gal. (128 oz) Bottle            |
| 80030022 | Res Care - 64 oz Bottle (Easy Feeder Refill) |
| 45148    | Res Care - 1 qt. (32 oz) Bottle              |

# Chemicals

## Easy Feeder

The Pro Easy Feeder automatically dispenses the right amount of Pro Res Care Cleaning Solution to maintain water softener efficiency. The Pro Easy Feeder is non-electric and easy to install and use. For use with 64 oz bottles of Res Care.

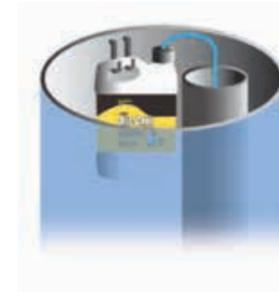

| Item #   | Description                     |
|----------|---------------------------------|
| 55030005 | Easy Feeder - 0.5 oz/day Feeder |
| 55030006 | Easy Feeder - 1.0 oz/day Feeder |



### Pot® Perm Greensand Iron Filter Regenerant

The Pro Easy Feeder automatically dispenses the right amount of Pro Res Care Cleaning Solution to maintain water softener efficiency. The Pro Easy Feeder is non-electric and easy to install and use. For use with 64 oz bottles of Res Care.

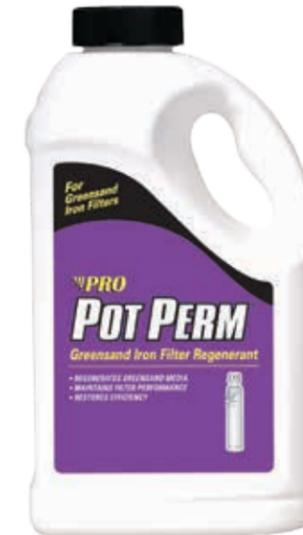

| Item #  | Description              |
|---------|--------------------------|
| 45143   | Pot Perm - 5 Lb. Bottle  |
| 45145-1 | Pot Perm - 10 Lb. Bottle |
| 50010   | Pot Perm - 55 Lb. Bottle |

# Chemicals

## Ban T® Alkaline Water Neutralizer

Ban T® (formerly called Pro-Citric Acid) is specifically formulated to effectively lower pH and remove iron and other contaminants from fouled water softeners. Ban T should be used as preventative maintenance on all water softeners in areas with moderate iron content to clean, restore and maintain the life of the softener. Ban T is an environmentally-friendly cleaning agent that removes hard water deposits and moderate iron staining from household fixtures.



| Item # | Description            |
|--------|------------------------|
| 45138  | Ban T - 1.5 lb. Bottle |



## Neutra 7® Acid Water Neutralizer®

Neutra 7® (formerly called Pro Soda Ash) is a proprietary alkaline blend which neutralizes acid water and keeps the injection point clean. This helps to eliminate corrosion of piping, pressure tanks, water heaters and fixtures without the hassle of constant cleaning of calcium build-up.

| Item # | Description             |
|--------|-------------------------|
| 45157  | Neutra 7 - 7 Lb. Bottle |
| 45158  | Neutra 7 - 40 Lb. Pail  |

# Hach Test Kits



#202300



#49018



#66751



#4918370



**NEW Dealer Combination Kit – Hardness, iron, sulphur, pH, Manganese, TDS**

| Item #    | Description                                       |
|-----------|---|
| 49145300  | 5B HARDNESS KIT - 0-30 GPG                        |
| 301227    | BUFFER SOLUTION HARDNESS 3 ,100 ML MDB 42432      |
| 49225401  | CN65 TOTAL/FREE CHLORINE KIT                      |
| 492060300 | DPD FREE CHLORINE PP 5ML PK/100.,14077-99         |
| 492060400 | DPD TOTAL CHLORINE PP 5ML PK/100. 14076-99        |
| 49183701  | HA62A HARDNESS, IRON, pH KIT                      |
| 301228    | HARDNESS 2 TEST SOLUTION,100 ML MDB 42532         |
| 301226    | HARDNESS 3 TEST SOLUTION,100 ML MDB               |
| 49018     | HS-C HYDROGEN SULPHIDE KIT (0 - 5 MG/L)           |
| 66751     | METER TDS MYRON L 0-5000 PPM 512M5                |
| 49146700  | MN5 MANGANESE (0-3 MG/L) KIT                      |
| 80050020  | PAPER, HYDROGEN SULFIDE 100                       |
| 66761     | PH/TEMP METER, pH-200, 0-14 pH                    |
| 80050007  | PH/TEMP WATERPROOF HYDRO TESTER, PH-80            |
| 4998366   | PILLOW, BUFFER CITRATE POWDER PK/100              |
| 301233    | PILLOW, FERROUS IRON REAGENT POWDER PK/100        |
| 4985199   | PILLOW, HARDNESS INDICATOR POWDER PK/100 Manver 2 |
| 4998499   | PILLOW, SODIUM PERIODATE POWDER PK/100            |
| 33004     | SOAP TEST KIT                                     |
| 4942411   | SOLUTION, HARDNESS 1, 500 ML                      |
| 4942511   | SOLUTION, HARDNESS 2, 500 ML                      |
| 4942616   | SOLUTION, HARDNESS 3, 500 ML                      |
| 49193701  | TA3 TANNIN - LIGNIN KIT                           |
| 49022     | TABLETS, ALKASELTZER 36                           |
| 80050008  | TDS-4 POCKET SIZE METER, HM DIGITAL               |
| 49016     | TEST KIT COMBINATION DEALER 2496101               |
| 202300    | TEST KIT, HA-77 HARDNESS & IRON                   |
| 80050052  | UNIVER 3 POWDER 28.3 GRAMS 213-20H                |
| 301518    | UNIVER 3 POWDER PILLOWS,PK/100                    |
| 80050038  | WIDE RANGE 4 pH SOLUTION                          |



**#49145300 hach 5b hardness test Kit 1 – 30 gpg**  
Trust the original Hach test kit! Simple drop count Titration measures hardness as CaCo3 (1 gpg = 17.1 mg / l). 100 tests.

# Spectrum Test Kits (U.S. Only)



|                     | Basic       | Standard    | Deluxe      |
|---------------------|-------------|-------------|-------------|
| <b>Components</b>   | <b>2403</b> | <b>2401</b> | <b>2404</b> |
| Sturdy Plastic Case | X           | X           | X           |
| Hardness Test       | X           | X           | X           |
| Iron Test           |             | X           | X           |
| pH Test             |             | X           | X           |
| Chlorine test       |             |             | X           |
| TDS Meter           |             |             | X           |

## REPLACEMENT SOLUTION CROSS REFERENCE CHART

|   | Basic       | Standard    | Deluxe      |
|---|-------------|-------------|-------------|
| <b>Solutions</b>  | <b>2403</b> | <b>2401</b> | <b>2404</b> |
| Hardness #1 Solution<br>2 oz. & 16 oz. Refill               | X           | X           |             |
| Hardness #2 Solution<br>2 oz. & 16 oz. Refill               | X           | X           |             |
| Hardness #3 Solution<br>2 oz. & 16 oz. Refill               | X           | X           |             |
| Hardness #1 Solution<br>1/2 oz. & 16 oz. Refill             |             |             | X           |
| Hardness #2 Solution<br>1/2 oz. & 16 oz. Refill             |             |             | X           |
| Hardness #3 Solution<br>1/2 oz. & 16 oz. Refill             |             |             | X           |
| Iron Reagent Foil Pack, 5ml<br>50 pack & 100 pack           |             | X           | X           |
| pH Solution Wide Range<br>1 oz. & 16 oz. Refill             |             | X           |             |
| pH Solution Wide Range<br>1/2 oz. & 16 oz. Refill           |             |             | X           |
| Chlorine Indicator Solution(OTO)<br>1/2 oz. & 16 oz. Refill |             |             | X           |



Deluxe Kit Hardness, Iron, pH, Chlorine & TDS



Basic Kit Hardness



Standard Kit Hardness, Iron, pH & Chlorine

# Mazzei Injectors

Mazzei® Injectors are high-efficiency, venturi-type, differential pressure injectors with internal mixing vanes. When a sufficient pressure difference exists between the inlet and outlet ports of the injector, a vacuum is created inside the injector body, which initiates suction of a liquid or gas through the suction port.

| Item #   | Description   |
|----------|---|
| 80040001 | Injector, Mazzei, 384-PP, 1/2" Inlet / Outlet             |
| 80040002 | Injector, Mazzei, 484A-PP, 3/4" Inlet / Outlet            |
| 80040003 | Injector, Mazzei, Bypass Kit 384-PP, 1/2" Inlet / Outlet  |
| 80040004 | Injector, Mazzei, Bypass Kit 484A-PP, 3/4" Inlet / Outlet |

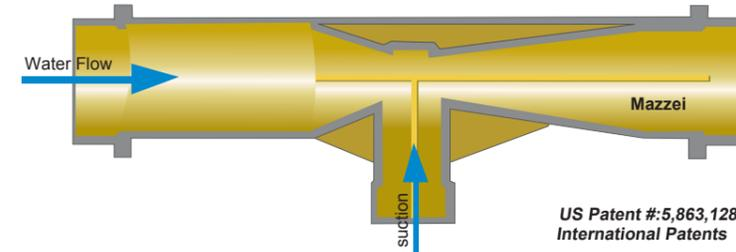

## How a Mazzei® Injector Works

When pressurized water enters the injector inlet, it is constricted toward the injection chamber and changes into a high-velocity jet stream. The increase in velocity through the injection chamber results in a decrease in pressure, thereby enabling an additive material to be drawn through the suction port and entrained into the water stream. As the jet stream is diffused toward the injector outlet, its velocity is reduced and it is reconverted into pressure energy (but at a pressure lower than injector inlet pressure).

Mazzei® Injectors are extremely efficient. They operate over a wide range of pressures and require only a minimal pressure differential between the inlet and outlet sides to initiate a vacuum at the suction port.

## Mattson / Witt K7225 Eductor

Used for iron removal - the K7225 Eductor is used in combination with an aeration tank and a backwashable filter containing special media adds a controlled amount of air to the water supply just before it enters the aeration tank. As the water sprays into the aeration tank it picks up more air. The oxygen in the air starts the natural iron removal process by oxidizing the iron and causing it to come out of solution. The iron can then be more easily filtered.



| Description                             |
|---|
| Eductor PVC 1" FXF 0-15 GPM Single Port |

# Tubing & Fittings (John Guest Quick Connect)

## Polypropylene Fittings

The PP Range of inch-size push-in fittings is offered for tube sizes 1/4" O.D. to 1/2" O.D. The fittings are manufactured in white polypropylene with food grade EPDM O-rings. They have been developed to satisfy the compatibility needs for a wide range of applications.

## Working Pressures and Temperatures

Water Max. 150 psi at 70°F (Max. 10 Bar at 20°C)

Max. 60 psi at 140°F (Max. 4 Bar at 60°C)

Min. 33°F/1°C



## Polypropylene Shut-Of Valve

The PPSV Range of Shut-Off Valve is offered for tube sizes 1/4" O.D. and 3/8" O.D., produced in polypropylene and fitted with EPDM O-rings. Polypropylene has the advantage of being more chemically resistant than acetal. The valves are for use with potable water. For use with other potable liquids please contact our Technical Support Department for guidance. The valves are not to be used with compressed air, explosive gases, petroleum spirits and other fuels or for heating systems.



## Working Pressures and Temperatures

Water Max. 150 psi at 70°F (Max. 10 bar at 20°C)

Max. 60 psi at 140°F (Max. 4 bar at 60°C)

Min. 33°F/1°C



## Polypropylene Fittings

The John Guest PE Range of plastic tubing is produced in Linear Low Density Polyethylene for cold and intermittent hot water applications. Our tubing is made from FDA compliant materials and is NSF International Standard 51 & 61 certified. John Guest LLDPE Tubing provides excellent resistance to environmental stress cracking as measured by ASTM D-1693 (10% IGEPAL). John Guest Polyethylene tubing is designed for use with John Guest Super Speedfit push-in fittings, John Guest Shut-Off Valves and virtually all standard tubing connectors.

# Tubing & Fittings (John Guest Quick Connect)

| Part # | Model Description |
|--------|-------------------|
|--------|-------------------|

## Male Connector - NPTF Thread

|           |                              |
|-----------|------------------------------|
| CI010821W | 1/4" X 1/8"-WHITE, (10 Pack) |
| CI010822W | 1/4" X 1/4"-WHITE, (10 Pack) |
| CI010823W | 1/4" X 3/8"-WHITE, (10 Pack) |
| CI011222W | 3/8" X 1/4"-WHITE, (10 Pack) |
| PI010821S | 1/4" X 1/8", (10 Pack)       |
| PI010822S | 1/4" X 1/4", (10 Pack)       |
| PI010823S | 1/4" X 3/8", (10 Pack)       |
| PI011221S | 3/8" X 1/8", (10 Pack)       |
| PI011222S | 3/8" X 1/4", (10 Pack)       |
| PI011223S | 3/8" X 3/8", (10 Pack)       |
| PI011224S | 3/8" X 1/2", (10 Pack)       |
| PI011623S | 1/2" X 3/8", (10 Pack)       |
| PI011624S | 1/2" X 1/2", (10 Pack)       |
| PI012026S | 5/8" X 3/4", (10 Pack)       |
| PP010822W | 1/4" X 1/4"-WHITE, (10 Pack) |
| PP010823W | 1/4" X 3/8"-WHITE, (10 Pack) |
| PP011222W | 3/8" X 1/4"-WHITE, (10 Pack) |
| PP011223W | 3/8" X 3/8", (10 Pack)       |
| PP011224W | 3/8" X 1/2", (10 Pack)       |
| PP011623W | 1/2" X 3/8", (10 Pack)       |
| PP011624W | 1/2" X 1/2", (10 Pack)       |

## Male Connector - Flare Male Connector (tube X thread)

|           |                        |
|-----------|------------------------|
| PI0108F4S | 1/4" X 1/4", (10 Pack) |
| PI0112F4S | 3/8" X 1/4", (10 Pack) |
| PI0112F6S | 3/8" X 3/8", (10 Pack) |
| PI0112F8S | 3/8" X 1/2", (10 Pack) |
| PI0116F8S | 1/2" X 1/2", (10 Pack) |

## Union Tee (for use when branching of - RO faucets & tanks)

|         |                         |
|---------|-------------------------|
| CI0208W | 1/4" - WHITE, (10 Pack) |
| CI0212W | 3/8" - WHITE, (10 Pack) |
| PI0208S | 1/4", (10 Pack)         |
| PI0212S | 3/8", (10 Pack)         |
| PI0216S | 1/2", (10 Pack)         |
| PP0208W | 1/4", (10 Pack)         |
| PP0212W | 3/8", (10 Pack)         |

## Reducing Tee (tube x tube x branch)

|             |                               |
|-------------|-------------------------------|
| PI301208S   | 3/8" X 3/8" X 1/4", (10 Pack) |
| PI301612S   | 1/2" X 1/2" X 3/8", (10 Pack) |
| PP30121208W | 3/8" X 3/8" X 1/4", (10 Pack) |
| PP301612W   | 1/2" X 1/2" X 3/8", (10 Pack) |

## Union Elbow (tube)

|         |                         |
|---------|-------------------------|
| CI0308W | 1/4" - WHITE, (10 Pack) |
| CI0312W | 3/8" - WHITE, (10 Pack) |
| PI0308S | 1/4", (10 Pack)         |
| PI0312S | 3/8", (10 Pack)         |
| PI0316S | 1/2", (10 Pack)         |
| PP0308W | 1/4", (10 Pack)         |
| PP0312W | 3/8", (10 Pack)         |
| PP0316W | 1/2", (10 Pack)         |

## Fixed Elbow (NPTF Thread - tube X thread)

|           |                                |
|-----------|--------------------------------|
| CI480821W | 1/4" X 1/8" - WHITE, (10 Pack) |
| CI480822W | 1/4" X 1/4" - WHITE, (10 Pack) |
| CI480823W | 1/4" X 3/8" - WHITE, (10 Pack) |
| CI481222W | 3/8" X 1/4" - WHITE, (10 Pack) |
| PI480821S | 1/4" X 1/8", (10 Pack)         |
| PI480822S | 1/4" X 1/4", (10 Pack)         |
| PI480823S | 1/4" X 3/8", (10 Pack)         |
| PI481222S | 3/8" X 1/4", (10 Pack)         |
| PI481223S | 3/8" X 3/8", (10 Pack)         |
| PI482024S | 5/8" X 1/2", (10 Pack)         |
| PP480821W | 1/4" X 1/8", (10 Pack)         |
| PP480822W | 1/4" X 1/4", (10 Pack)         |
| PP480823W | 1/4" X 3/8", (10 Pack)         |
| PP481222W | 3/8" X 1/4", (10 Pack)         |
| PP481223W | 3/8" X 3/8", (10 Pack)         |

## Reducing Elbow (tube X tube)

|           |                        |
|-----------|------------------------|
| PI211208S | 3/8" X 1/4", (10 Pack) |
| PI211612S | 1/2" X 3/8", (10 Pack) |
| PP211208W | 3/8" X 1/4", (10 Pack) |
| PP211612W | 1/2" X 3/8", (10 Pack) |

## Plug In/Stem Elbow (stem X tube)

|           |                                |
|-----------|--------------------------------|
| CI220808W | 1/4" X 1/4" - WHITE, (10 Pack) |
| CI221208W | 3/8" X 1/4" - WHITE, (10 Pack) |
| CI221212W | 3/8" X 3/8" - WHITE, (10 Pack) |
| PI220808S | 1/4" X 1/4", (10 Pack)         |
| PI221208S | 3/8" X 1/4", (10 Pack)         |
| PI221212S | 3/8" X 3/8", (10 Pack)         |
| PI221616S | 1/2" X 1/2", (10 Pack)         |
| PP220808W | 1/4" X 1/4", (10 Pack)         |
| PP221208W | 3/8" X 1/4", (10 Pack)         |
| PP221212W | 3/8" X 3/8", (10 Pack)         |
| PP221616W | 1/2" X 1/2", (10 Pack)         |

# Tubing & Fittings (John Guest Quick Connect)

## Union Connector (tube X tube)



|         |                         |
|---------|-------------------------|
| CI0408W | 1/4" - WHITE, (10 Pack) |
| CI0412W | 3/8" - WHITE, (10 Pack) |
| PI0408S | 1/4", (10 Pack)         |
| PI0412S | 3/8", (10 Pack)         |
| PI0416S | 1/2", (10 Pack)         |
| PP0408W | 1/4", (10 Pack)         |
| PP0412W | 3/8", (10 Pack)         |
| PP0416W | 1/2", (10 Pack)         |

## Reducing Union (union X tube X tube)



|           |                        |
|-----------|------------------------|
| PI201208S | 3/8" X 1/4", (10 Pack) |
| PI201612S | 1/2" X 3/8", (10 Pack) |
| PP201208W | 3/8" X 1/4", (10 Pack) |
| PP201612W | 1/2" X 3/8", (10 Pack) |

## Stem Adaptor (NPTF Thread - stem X thread)



|           |                                |
|-----------|--------------------------------|
| CI050821W | 1/4" X 1/8" - WHITE, (10 Pack) |
| CI050822W | 1/4" X 1/4" - WHITE, (10 Pack) |
| CI051222W | 3/8" X 1/4" - WHITE, (10 Pack) |
| CI051223W | 3/8" X 3/8" - WHITE, (10 Pack) |
| PI050821S | 1/4" X 1/8", (10 Pack)         |
| PI050822S | 1/4" X 1/4", (10 Pack)         |
| PI051222S | 3/8" X 1/4", (10 Pack)         |
| PI051223S | 3/8" X 3/8", (10 Pack)         |
| PI051623S | 1/2" X 3/8", (10 Pack)         |
| PI051624S | 1/2" X 1/2", (10 Pack)         |
| PP050821W | 1/4" X 1/8", (10 Pack)         |
| PP050822W | 1/4" X 1/4", (10 Pack)         |
| PP051222W | 3/8" X 1/4", (10 Pack)         |
| PP051223W | 3/8" X 3/8", (10 Pack)         |
| PP051623W | 1/2" X 3/8", (10 Pack)         |
| PP051624W | 1/2" X 1/2", (10 Pack)         |

## Stem Reducer (stem X thread)



|           |                                |
|-----------|--------------------------------|
| CI061208W | 3/8" X 1/4" - WHITE, (10 Pack) |
| PI061208S | 3/8" X 1/4", (10 Pack)         |
| PI061612S | 1/2" X 3/8", (10 Pack)         |
| PP061208W | 3/8" X 1/4", (10 Pack)         |
| PP061612W | 1/2" X 3/8", (10 Pack)         |

## Bulkhead Union (tube X mounting hole diameter)



|         |                                |
|---------|--------------------------------|
| CI1208W | 1/4" - 0.67 - WHITE, (10 Pack) |
| PI1208S | 1/4" - 0.67, (10 Pack)         |
| PI1212S | 3/8" - 0.83, (10 Pack)         |
| PI1216S | 1/2" - 1.06, (10 Pack)         |
| PP1208W | 1/4" - 0.67, (10 Pack)         |
| PP1212W | 3/8" - 0.83, (10 Pack)         |

|         |                        |
|---------|------------------------|
| PP1216W | 1/2" - 1.06, (10 Pack) |
|---------|------------------------|

## Reducing Bulkhead Union (tube X tube X mounting hole diameter)



|           |                               |
|-----------|-------------------------------|
| PI121208S | 3/8" X 1/4" - 0.83, (10 Pack) |
| PP121208W | 3/8" X 1/4" - 0.83, (10 Pack) |

## Faucet Connector UNS Thread (tube X thread)



|           |                         |
|-----------|-------------------------|
| CI3208U7S | 1/4" X 7/16", (10 Pack) |
| CI3212U7S | 3/8" X 7/16", (10 Pack) |
| PP3208U7W | 1/4" X 7/16", (10 Pack) |
| PP3212U7W | 3/8" X 7/16", (10 Pack) |

## Stem to Hose Barb (stem X hose barb)



|           |                        |
|-----------|------------------------|
| PI250808S | 1/4" X 1/4", (10 Pack) |
| PI251208S | 3/8" X 1/4", (10 Pack) |
| PI251212S | 3/8" X 3/8", (10 Pack) |
| PI251216S | 3/8" X 1/2", (10 Pack) |
| PP251212W | 3/8" X 3/8", (10 Pack) |
| PP251216W | 3/8" X 1/2", (10 Pack) |
| PP251612W | 1/2" X 3/8", (10 Pack) |
| PP251616W | 1/2" X 1/2", (10 Pack) |

## Stem to Hose Barb Long Version (stem X hose barb)



|            |                        |
|------------|------------------------|
| PI251212SL | 3/8" X 3/8", (10 Pack) |
| PI290808S  | 1/4" X 1/4", (10 Pack) |
| PI291208S  | 3/8" X 1/4", (10 Pack) |

## Female Connector NPTF Thread (tube X thread)



|           |                        |
|-----------|------------------------|
| PI450822S | 1/4" X 1/4", (10 Pack) |
| PI451222S | 3/8" X 1/4", (10 Pack) |
| PP450822W | 1/4" X 1/4", (10 Pack) |
| PP451222W | 3/8" X 1/4", (10 Pack) |

## Female Flare Connector FFL (tube X thread)



|           |                        |
|-----------|------------------------|
| PI4512F4S | 3/8" X 1/4", (10 Pack) |
| PI4512F6S | 3/8" X 3/8", (10 Pack) |

## Plug (stem)

|         |                 |
|---------|-----------------|
| PI0808S | 1/4", (10 Pack) |
| PI0812S | 3/8", (10 Pack) |
| PI0816S | 1/2", (10 Pack) |
| PP0808W | 1/4", (10 Pack) |
| PP0812W | 3/8", (10 Pack) |
| PP0816W | 1/2", (10 Pack) |

## End Stop (tube)



|         |                 |
|---------|-----------------|
| PI4608S | 1/4", (10 Pack) |
| PI4612S | 3/8", (10 Pack) |

# Tubing & Fittings (John Guest Quick Connect)

|           |                             |
|-----------|-----------------------------|
| PEI202820 | 3/4 x 1/2 Reducing Coupler, |
|-----------|-----------------------------|

## PEX Plug-in Elbow



|           |   |
|-----------|---|
| PEI222020 | PEX Plug-In Elbow, 1/2" Stem - 1/2" Pipe, |
| PEI222828 | PEX Plug-In Elbow, 3/4" Stem - 3/4" Pipe, |

## PEX Reducing Tee



|          |  |
|----------|--|
| PEI3028A | PEX Reducing Tee 3/4" x 3/4" x 1/2" CTS, |
| PEI3028B | PEX Reducing Tee 3/4" x 1/2" x 1/2" CTS, |
| PEI3028C | PEX Reducing Tee 1/2" x 1/2" x 3/4" CTS, |
| PEI3028D | PEX Reducing Tee 3/4" x 1/2" x 3/4" CTS, |

## PEX Stackable Tee



|           |   |
|-----------|---|
| PEI532020 | PEX Stackable Tee 1/2" CTS x 1/2" Stem x 1/2" CTS |
| PEI532820 | PEX Stackable Tee 3/4" CTS x 3/4" Stem x 1/2" CTS |
| PEI532828 | PEX Stackable Tee 3/4" CTS x 3/4" Stem x 3/4" CTS |

## PEX Miscellaneous



|             |  |
|-------------|--|
| PEIBTC2034  | PEX Female Swivel Elbow, 1/2" CTS x 1/2" NPS             |
| PEIBTC20C75 | PEX Female Ballcock Elbow, 1/2" CTS x 7/8"-15/16 UNS     |
| PEISTC2034  | PEX Female Swivel Connector, 1/2" CTS x 1/2" NPS         |
| PEISTC20C75 | PEX Female Ballcock Connector, 1/2" CTS x 7/8"-15/16 UNS |

# Water Conditioning Glossary

**Absorption** - The process in which one substance is taken into the body of another substance, termed the absorbent. An example is the absorption of water into soil.

**Acid** - A substance which releases hydrogen ions when dissolved in water. Most acids will dissolve the common metals and will react with a base to form a neutral salt and water.

**Activated Carbon** - A granular material usually produced by the roasting of cellulose base substances, such as wood or coconut shells, in the absence of air. It has a very porous structure and is used in water conditioning as an adsorbent of organic matter and certain dissolved gases. Sometimes called "activated charcoal."

**Adsorption** - The process in which matter adheres to the surface of the adsorbent.

**Aeration** - The process in which air is brought into intimate contact with water, often by spraying water through air or by bubbling air through water. Aeration may be used to add oxygen to the water for oxidation of matter such as iron or to cause the release of dissolved gases such as carbon dioxide or hydrogen sulfide from the water.

**Alkalinity** - The quantitative capacity of a water or water solution to neutralize an acid. It is usually measured by titration with a standard acid solution of sulfuric acid and expressed in terms of its calcium carbonate equivalent.

**Anion** - A negatively charged ion in solution such as bicarbonate, chloride or sulfate.

**Anion Exchange** - An ion exchange process in which anions in solution are exchanged for other anions from an ion exchanger. In demineralization, for example, bicarbonate, chloride and sulfate anions are removed from solution in exchange for a chemically equivalent number of hydroxide anions from the anion exchange resin.

**Aquifer** - A layer or zone below the surface of the earth which is capable of yielding a significant volume of water.  
**Atom** - The smallest particle of an element that can exist either alone or in combination with smaller particles of the same element or of a different element.

**Attrition** - The process in which solids are worn down or ground down by friction, often between particles of the same material. Filter media and ion exchange materials are subject to attrition during backwashing, regeneration and service.

**Backwash** - The process in which beds of filter or ion exchange media are subjected to flow opposite to service flow direction to loosen the bed and to flush suspended matter collected during the service run to waste.  
**Bacteria** - Unicellular micro-organisms which typically reproduce by cell division. Although usually classed as plants, bacteria contain no chlorophyll.

**Bacteriostatic** - A feature of a carbon filter that is supposed to inhibit the growth of bacteria within the filter - usually by the addition of silver.

**Base** - A substance which releases hydroxyl ions when dissolved in water. Bases react with acids to form a neutral salt and water.

**Bed** - The ion exchange or filter media in a column or other tank or operational vessel.

**Bed Depth** - The height of the ion exchange or filter media in the vessel after preparation for service.

**Boiling Point** - The temperature at which a substance will change from a liquid state to a gaseous or vapor state.

**Brackish Water** - Water containing between 1000 and 1500 mg/l of dissolved solids is generally considered to be brackish.

**Brine (R.O.)** - Same as reject water. One of two streams of fluids generated by a reverse osmosis unit. It contains the impurities removed from the feed water.

**Brine (Softening)** - A strong solution of salt(s), such as sodium chloride, and water used in the regeneration of ion exchange water softeners but also applied to the mixed sodium, calcium and magnesium chloride waste solution from regeneration.

**Calcium (Ca)** - One of the principal elements making up the earth's crust, the compounds of which, when dissolved, make the water hard. The presence of calcium in water is a factor contributing to the formation of scale and insoluble soap curds which are a means of clearly identifying hard water.

**Calcium Hypochlorite (CaCl<sub>2</sub>O<sub>2</sub>)** - A chemical compound used as a bleach and a source of chlorine water treatment; specifically useful because it is stable as a dry powder and can be formed into tablets.

**Capacity** - An expression of the quantity of an undesirable material which can be removed by a water conditioner between servicing of the media (i.e. cleaning, regeneration or replacement) as determined under standard test conditions. For ion exchange water softeners, the capacity is expressed in grains of hardness removal between successive regenerations and is related to the pounds of salt used in regeneration. For filters, the capacity may be expressed in the length of time or total gallons delivered between servicing.

**Caustic Soda** - The common name for sodium hydroxide.

**Cation** - An ion with a positive electrical charge, such as calcium, magnesium and sodium.

**Cation Exchange** - Ion exchange process in which cations in solution are exchanged for other cations from an ion exchanger.

**Cellulose Acetate (CA) and Cellulose Triacetate (CTA)** - A family of synthetic materials based on cellulose used to make reverse osmosis membranes. While CTA is superior to CA, under adverse water conditions both are effective in removing a wide spectrum of impurities from water. The disadvantage of cellulose-type membranes is that they are subject to bacterial attack, particularly in unchlorinated water supplies. CTA has superior bacterial resistance.

# Water Conditioning Glossary

**Channeling** - The flow of water or other solution in a limited number of passages in a filter or ion exchange bed instead of distributed flow through all passages in the bed.

**Chloramines** - Chemical complexes formed from the reaction between ammonia and chlorine. They are presently being used to disinfect municipal water supplies because, unlike chlorine, they do not combine with organics in the water to form potentially dangerous carcinogens such as trihalomethanes (THMs). Chloramines can exist in three forms, the proportions of which depend on the physical and chemical properties of the water. Water containing chloramines may not be used for fish or kidney dialysis equipment.

**Chlorides (Cl)** - an ion which forms acids when combined with hydrogen and salts when combined with metal ions. Chlorides can be corrosive and impart a salty taste to water.

**Chlorine (Cl<sub>2</sub>)** - A gas widely used in the disinfection of water and an oxidizing agent for organic matter, iron, etc.

**Coagulant** - A material, such as alum, which will form a gelatinous precipitate in water and cause the agglomeration of finely divided particles into larger particles which can then be removed by settling and/or filtration.

**Colloid** - Very finely divided solid particles which will not settle out of a solution; intermediate between a true dissolved particle and a suspended solid which will settle out of solution. The removal of colloidal particles usually requires coagulation to form larger particles which may be removed by sedimentation and/or filtration.

**Compensated Hardness** - A calculated value based on the total hardness - the magnesium to calcium ratio and the sodium concentration of a water. It is used to correct for the reductions in hardness removal capacity caused by these factors in cation exchange water softeners. No single method of calculation has been widely accepted.

**Conductivity** - The quality or power to carry electrical current. In water, the conductivity is related to the concentration of ions capable of carrying electrical current.

**Contact Time** - The length of time water is in direct contact with activated carbon (R.O.) or chlorine (chlorination system.) This is a major factor in determining how effectively impurities will be removed.

**Corrosion** - The destructive disintegration of a metal by electrochemical means.

**Cycle Time** - The amount of time in seconds elapsed between pump start and pump shut-down.

**Dechlorination** - The removal of excess chlorine residual, often after super-chlorination.

**Deionization (DI)** - The removal of all ionized minerals and salts (both organic and inorganic) from a solution by a two-phase ion exchange procedure. First, positively charged ions are exchanged for a chemically equivalent amount of hydrogen ions. Second, negatively charged

ions are removed by an ion exchange resin for a chemically equivalent amount of hydrogen ions. The hydrogen and hydroxide ions introduced in this process unite to form water molecules. The term is often used interchangeably with demineralization.

**Disinfection** - A process in which pathogenic, disease producing bacteria are killed. May involve disinfecting agents such as chlorine or physical processes such as heating.

**Dissolved Solids** - The weight of matter in true solution in a stated volume of water. Includes both inorganic and organic matter and is usually determined by weighing the residue after evaporation of the water at 105°F or 180°C.

**Distillation** - The process in which a liquid, such as water, is converted into its vapor state by heating and the vapor cooled and condensed to the liquid state and collected. Used to remove solids and other impurities from water. Multiple distillations are required for extreme purity.  
**DNA** - Deoxyribonucleic acid constituting the genetic material of the chromosome in a cell, responsible for reproductive characteristics.

**Drawdown** - The amount of water delivered by the storage tank between pump shut-down and pump start.

**E Coli (Escherichia Coli)** - One of the members of the coliform group of bacteria indicating fecal contamination.

**Effluent** - The stream emerging from a unit, system or process such as the softened water from an ion exchange softener.

**Exhaustion** - The state of an ion exchange material in which it is no longer capable of effective function due to the depletion of the initial supply of exchangeable ions. The exhaustion point may be defined in terms of a limiting concentration of matter in the effluent or, in the case of demineralization, in terms of electrical conductivity.

**Fecal** - Matter containing or derived from animal or human waste.

**Feed Pressure** - The pressure at which water is supplied to the R.O. module.

**Feed Water** - A term which refers to the water supply that is put into a water treatment system for processing (removal of impurities.)

**Flocculation** - The agglomeration of finely divided suspended solids into larger, usually gelatinous, particles. The development of a 'floc' after treatment with a coagulant by gentle stirring or mixing.

**Flow Control** - A device designed to limit the flow of water or regenerant to a predetermined value over a broad range of inlet water pressures.

**Flow Rate** - The quantity of water or regenerant which passes a given point in a specified unit of time, often expressed in gallons per minute.

**Flux** - The flow rate of water through reverse osmosis membranes, per square foot of surface.

**Fouling** - The process in which undesirable foreign matter accumulates in a bed of filter media or ion exchanger,

# Water Conditioning Glossary

clogging pores and coating surfaces and thus inhibiting or retarding the proper operation of the bed.

**Freeboard** - The vertical distance between a bed of filter media or ion exchange material and the overflow or collector for backwash water. The height above the bed of granular media available for bed expansion during backwashing. May be expressed either as a linear distance or a percentage of bed depth.

**Grain (gr)** - A unit of weight equal to 1/7000 of a pound or 0.0648 gram.

**Grain per Gallon (gpg)** - A common basis for reporting water analysis in the United States and Canada. One grain per U.S. gallon equals 17.12 milligrams per liter (mg/l) or parts per million (ppm). One grain per British (Imperial) gallon equals 14.3 mg/l or ppm.

**Greensand** - A natural mineral, primarily composed of complex silicates, which can be coated with manganese oxide to form a catalytic absorptive surface. This surface is used to attract ferrous iron and manganese as well as to absorb dissolved oxygen which is used to oxidize iron, manganese or hydrogen sulfide.

**Hardness** - A characteristic of natural water due to the presence of dissolved calcium and magnesium. Water hardness is responsible for most scale formation in pipes and water heaters and forms insoluble "curd" when it reacts with soaps. Hardness is usually expressed in grains per gallon (gpg), parts per million (ppm) or milligrams per liter (mg/l), all as calcium carbonate equivalent.

**Hard Water** - Water with a total hardness of 1 gpg or more as calcium carbonate equivalent.

**Hydrologic Cycle** - The natural water cycle, including precipitation of water from the atmosphere as rain or snow, flow of water over or through the earth and evaporation or transpiration to water vapor in the atmosphere.

**Hydrogen Sulfide (H<sub>2</sub>S)** - A gas characterized by an offensive odor, commonly referred to as "rotten egg" odor. Flammable and poisonous in high concentrations, corrosive to most metals and can even tarnish silver. Detectable by most people in concentrations as low as 0.5 ppm.

**Hydrocharger** - Trade name of a particular type of air induction or injector valve.

**Hydrolysis** - The chemical degradation of an R.O. membrane in water due to certain conditions such as high pH. Cellulose based membranes are quite susceptible to hydrolysis while the TFC type are virtually immune.

**Influent** - The stream entering a unit, stream or process, such as the hard water entering an ion exchange water softener.

**Ion** - An atom, or group of atoms, which function as a unit and have a positive or negative electrical charge due to the gain or loss of one or more electrons.

**Ion Exchange** - A reversible process in which ions are released from an insoluble permanent material in

exchange for other ions in a surrounding solution; the direction of the exchange depends upon the affinities of the ion exchanger for the ions present and the concentrations of the ions in the solution.

**Iron (Fe)** - An element often found dissolved in ground water (in the form of ferrous iron) in concentrations usually ranging from 0-10 ppm (mg/l). It is objectionable in water supplies because of the staining caused after oxidation and precipitation (as ferric hydroxide); because of the tastes; and because of unsightly colors produced when iron reacts with tannins in beverages such as coffee and tea.

**Iron Bacteria** - Organisms which are capable of utilizing ferrous iron, either from the water or from steel pipe in their metabolism and precipitating ferric hydroxide in their sheaths and gelatinous deposits. These organisms tend to collect in pipelines and tanks during periods of low flow and to break loose in slugs of turbid water to create staining, taste and odor problems.

**Magnesium (Mg)** - One of the elements making up the earth's crust, the compounds of which, when dissolved in water, make the water hard. The presence of magnesium in water is a factor contributing to the formation of scale and insoluble soap curds.

**Manganese (Mn)** - An element sometimes found dissolved in ground water, usually with dissolved iron but in lower concentrations. Causes black stains and other problems similar to iron.

**Manganese Greensand** - Greensand which has been processed to incorporate in its pores and on its surface the higher oxides of manganese. The product has a mild oxidizing power and is often used in the oxidation and precipitation of iron, manganese and/or hydrogen sulfide and their removal from water.

**Mechanical Filtration** - The process of removing suspended particles from water by a straining action. The finest mechanical filters can remove bacteria as small as 0.2 microns.

**Media** - The selected materials in a filter that form the barrier to the passage of certain suspended solids or dissolved minerals. (Singular of media is medium).

**Milligrams per Liter (mg/l)** - A unit concentration of matter used in reporting the results of water and wastewater analysis. In dilute water solutions, it is practically equal to parts per million but varies from the ppm in concentrated solutions such as brine. As most analysis are performed on measured volumes of water, the mg/l is a more accurate expression of the concentration and is the preferred unit of measure.

**Micron** - A linear measure equal to one millionth of a meter or .00003937 inch. The symbol for the micron is the Greek letter "μ".

**Micron Rating** - The term applied to a filter or filter medium to indicate the particle size above which all suspended solids will be removed throughout the rated capacity. As used in industry standards, this is an "absolute" not "nominal" rating. (Refer to S-200, Recommended

# Water Conditioning Glossary

Industry Standards for Household & Commercial Water Filters.)

**Mineral** - A term applied to inorganic substances such as rocks and similar matter found in the earth strata as opposed to organic substances such as plant and animal matter. Minerals normally have definite chemical composition and crystal structure. The term is also applied to matter derived from minerals such as the inorganic ions found in water. The term has been incorrectly applied to ion exchangers, even though most of the modern materials are organic ion exchange resins.

**Mineral Salts** - The form in which minerals from dissolved rock exist in water. Same as Total Dissolved Solids. This is the so-called inorganic form of minerals. In excess, they cause water to have a disagreeable taste. Some are harmful to human health.

**Molecular Weight** - The sum of the atomic weights of the individual atoms (from a periodic chart) that make up a molecule of a particular substance (e.g. H<sub>2</sub>O) H=1 atomic weight, O=16 atomic weight, therefore, molecular weight = 2 + 16 = 18.) Cellulose based membranes can remove substances as light as MW of 300, while TFC type membranes remove substances as light as MW of 200.

**Nanometer** - A measure of a wavelength in the electromagnetic spectrum. One nanometer equals 109 meter.

**Neutralization** - In general, the addition of either an acid or a base to a solution as required to produce a neutral solution. The use of alkaline or basic materials to neutralize the acidity of some waters is common practice in water conditioning.

**Organic Iron** - A ferrous iron molecule which is enveloped in an organically complex molecule that resists oxidation. May be present in water that contains a great deal of colored colloidal turbidity.

**Organics** - Any of the compounds whose chemical structure is based on carbon (e.g. carbon dioxide, wood, sugar, protein, plastics, methane, THM, TCE, etc.)

**Osmosis** - A process of diffusion of a solvent, such as water through a semipermeable membrane, which will transmit the solvent but impede most dissolved substances. The normal flow of solvent is from the dilute solution to the concentrated solution. (See Reverse Osmosis).

**Osmotic Pressure** - The pressure created by the tendency of water to flow in osmosis. Every 100 ppm of TDS generates about 1 pound per square inch (psi) of osmotic pressure. This osmotic pressure must first be overcome by the water pressure for the reverse osmosis membrane to be effective.

**Oxidation** - A chemical process in which electrons are removed from an atom, ion or compound. The addition of oxygen is a specific form of oxidation. Combustion is an extremely rapid form of oxidation while the rusting of iron is a slow form.

**Oxidizing Agents** - Any substance that oxidizes another substance and is itself reduced in the process.

Common examples include: oxygen, chlorine, potassium permanganate, hydrogen peroxide, iodine and ozone.

**Ozone (O<sub>3</sub>)** - An unstable form of oxygen occurring naturally in the upper atmosphere or artificially produced because of its strong oxidizing or disinfection characteristics.

**Particle Size** - As used in industry standards, the size of a particle suspended in water as determined by its smallest dimension, usually expressed in microns.

**Parts per Million (ppm)** - A common basis for reporting the results of water and waste water analysis, indicating the number of parts by weight of water or other solvent. In dilute water solutions, one part per million is practically equal to one milligram per liter, which is the preferred unit. 17.12 ppm equals one grain per U.S. gallon.

**Pathogen** - An organism which may cause disease.

**PCB** - Polychlorinated Biphenyls - A highly toxic organic contaminant found in water supplies which is suspected of causing cancer in humans.

**pH** - or the potential of hydrogen ion activity or concentration. pH is a measure of the intensity of the acidity or alkalinity of water on a scale from 0 to 14, with 7 being neutral. When acidity is increased, the hydrogen ion concentration increases, resulting in a lower pH value. Similarly, when alkalinity is increased, the hydrogen ion concentration decreases, resulting in higher pH. The pH value is an exponential function so that pH is 10 times as alkaline as pH 9 and 100 times as alkaline as pH 8. Similarly, a pH 4 is 100 times as acid as pH 6 and 1000 times as acid as pH 7.

**Potassium Chloride (KCl)** - a compound consisting of potassium and chloride, becoming increasingly popular as a substitute for sodium chloride in regenerating water softeners.

**Potassium Permanganate (KMnO<sub>4</sub>)** - A powerful oxidizing agent consisting of dark purple crystals with blue metallic sheen. Explosive in contact with sulfuric acid or hydrogen peroxide. Increases flammability of combustible materials. Used to renew the black manganese oxide coating on greensand media.

**Precipitate** - To cause a dissolved substance to form a solid particle which can be removed by settling or filtering such as in the removal of dissolved iron by oxidation, precipitation and filtration. The term is also used to refer to the solid formed and the condensation of water in the atmosphere to form rain or snow.

**Pre-treatment** - Whatever alterations of the raw feed water are required to prevent damage to the reverse osmosis membrane.

**Product Water** - The pure water that has been separated from the feed water stream by the reverse osmosis membrane.

**Pumping Rate** - The amount of actual water that can be drawn from a pressure system expressed in gallons per minute (gpm) obtained by dividing the drawdown (gallons) by the cycle time (seconds) and multiplying the result by 60 (seconds.)







# WaterGroup

**Canada West**  
**655 Park St.**  
**Regina, SK S4N 5N1**

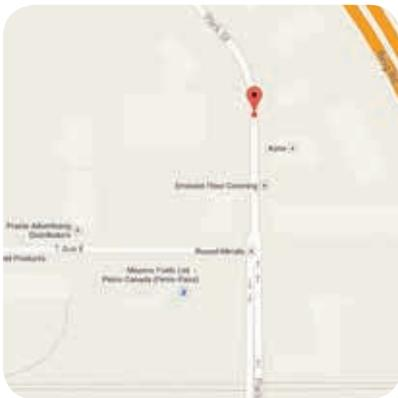

**Canada East**  
**490 Pinebush Rd Unit 1**  
**Cambridge ON N1T 0A5**



**U.S.A.**  
**8437 10th Ave North**  
**Golden Valley, MN 55427**



**U.S.A.**  
**760 Mayflower Park Dr**  
**Suite 110**  
**Carmel, IN 46032**



**CALL US TOLL-FREE**

**1-877-288-9888**

[www.watergroup.com](http://www.watergroup.com)

Regina, SK • Cambridge, ON • Carmel, IN • Golden Valley, MN