



SUNTEMP

**BASEBOARD
RADIATION**

Imperial 700-A1





SUNTEMP

Imperial 700-A1

Beautiful? Obviously. But first and foremost, **IMPERIAL 700-A1** has a heating job to do. And never before has baseboard radiation been so well equipped to do it!

Tops in all categories. . . comfort . . .
silence . . . convenience . . . strength . . .
safety . . . cleanliness . . . styling . . .
efficiency . . . economy.

Not just by words, but by such solid facts. . .

COMBINED BACK PANEL AND TOP

Lends itself to either flush or recessed installation, with usual measuring and leveling eliminated.

DAMPER-LOUVER

Regulated at a touch from full open to closed...or to any point between...for true perimeter heat control. Painting after installation will not hamper its operation.

RETURN TUBE HANGER

The improved bracket design now provides an area to tuck a return tube inside, concealed from view. The return tube hanger locates in pre-punched slot and hole to accurately locate and support the tube.

SLIDING SUPPORT BRACKET

Permits easy installation of the bracket anywhere along the back panel. Provides radius pivot that holds damper-louver. Also supports heating element, front panel and return pipe line.

EXPANDED COPPER TUBE END

Need for couplings is eliminated by expansion of one end of tubing to receive small end of the next element.

HEATING ELEMENT WITH HEAVY-GAUGE CHANNELIZED FINS... AND DEEP-DRAWN FIN COLLARS

SUPER STRONG... Heavy channelized fins are most rigid. Deep-drawn collars bond strongest.

SUPER SILENT... Channels end "oil-can" ping noises. Cradles end lateral expansion noises.

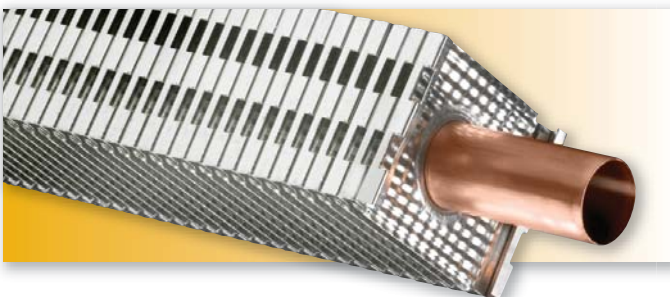

BACK PANEL EXTENDED BOTTOM

Provides track for support bracket...for finished floor appearance...a bonus which eliminates an area of dust accumulation and the need for special molding.

LOCKING FRONT PANEL

The enclosure front attaches to the support bracket by means of a positive latch. This prevents dislodging accidentally or by playful children. Now available in 18 gauge.

HEATING ELEMENT

With deep-drawn collars instead of holes, the channelized fins sheath the expanded copper tubing for strongest mechanical bond and maximum thermal contact. These deeply channelized fins with double bent boxed ends have 36% more heating surface and absorb the outward expansion of the tubing to prevent pinging noises.

EXPANSION CRADLE

Made of durable polypropylene, it isolates the heating element from contact with the front panel, back panel and support bracket. Its smooth gliding surface eliminates noises caused by lateral expansion of tubing. Small dimples engage into the small openings on the side of the element to help lock onto the fins.

SUPER SAFE... Double bent boxed ends prevent cut fingers for complete safety.

SUPER EFFICIENT... 36% more fin radiating surface. Maximum tube-to-fin heat transfer.

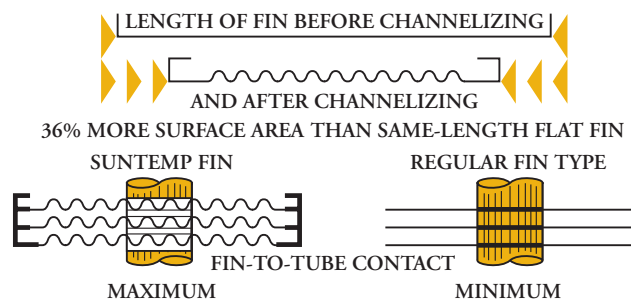

RATINGS

IMPERIAL 700-A1-3/4" HEATING CAPACITIES

WATER FLOW RATE LB./HR.	HOT WATER — BTU/HR./LIN. FT. 										
	150°	160°	170°	180°	190°	200°	210°	215°	220°	230°	240°
2000 lbs./hr.	390	450	530	590	660	730	790	820	860	930	990
500lbs./hr.	370	430	500	560	620	690	750	780	810	880	940

IMPERIAL 700-A1-1/2" HEATING CAPACITIES

WATER FLOW RATE LB./HR.	HOT WATER — BTU/HR./LIN. FT.										
	150°	160°	170°	180°	190°	200°	210°	215°	220°	230°	240°
2000 lbs./hr.	410	480	550	610	680	740	810	840	880	950	1010
500lbs./hr.	390	450	520	580	640	700	770	800	830	900	960

PRESSURE DROP — INCHES/LIN. FT.

TUBE SIZE	1 GPM	4 GPM
3/4"	.047	.525
1/2"	.260	2.880

NOTES:

All the ratings noted include a 15% addition for heating effect. These ratings are based on active length, which is total length less 4^{3/4}".

The use of ratings at 4 GPM (2000 lbs. per hour) is limited to installations where the water flow rate through the baseboard unit is equal to or greater than 4 GPM.

Where the water flow rate through the baseboard is not known, the rating of 1 GPM (500 lbs. per hour) must be used. Suntemp Imperial heating elements are constructed of 3/4" and 1/2" nominal copper tubing, mechanically expanded within aluminum fins. IMPERIAL 700-A1-3/4" fin dimensions are 2" x 2^{13/32}" x .010; fins are spaced 51.1 fins per lineal foot. IMPERIAL 700-A1-1/2" fin dimensions are 2^{1/8}" x 2^{1/8}" x .008; fins are spaced 52 fins per lineal foot. External finish of element: unpainted, tubing and fins.



ENCLOSURE FITS ANY DÉCOR

It's low—7^{7/8}"...and narrow—2^{13/16}" Satin-white baked finish. Front outlet prevents wall streaking. Easy to clean rounded-edge surfaces.



TAB-ON ACCESSORIES

Easy, speedy no-tool installation. Standard and hinged types available. All tab type accessories stay where they were put.



HEAT CONTROL DAMPER-LOUVER

Can be operated, by a touch, from any point along its length. Deflects air through front outlet so walls can not get dirt-streaked. Painting, after installation, does not hamper its later operation. Also, features a concealed return tube.

DIMENSIONS

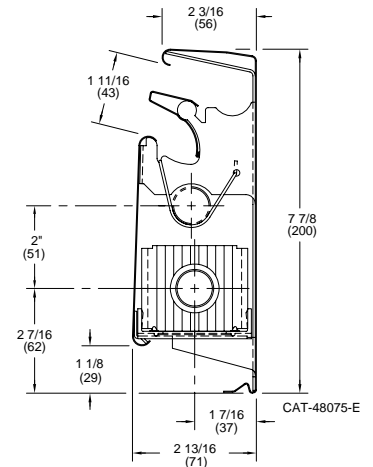

NOTE: DIMENSIONS IN "()" ARE SHOWN IN MILLIMETERS.

ENCLOSURE LENGTHS	2' - 14'
ELEMENT LENGTHS	3' - 8'

NOTE: Consult factory for palletized quantities.

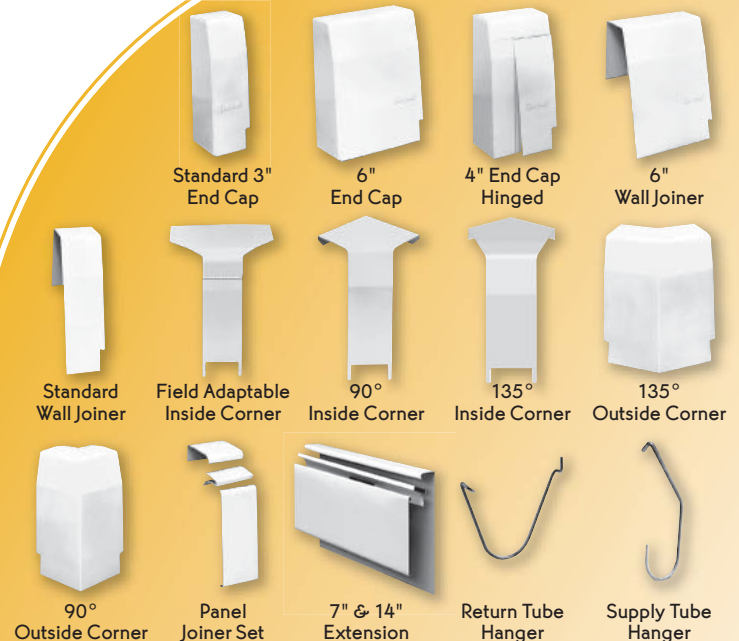

PACKAGING

IMPERIAL 700-A1 COMPLETE UNIT SINGLE PACK

IMPERIAL 700-A1 ENCLOSURE ONLY SINGLE PACK

IMPERIAL 700-A1-³/₄" & IMPERIAL 700-¹/₂" ELEMENT ONLY FOUR UNIT PACK

CATALOG NUMBER		UNIT LENGTH	SPLICE PLATES	CATALOG NUMBER		UNIT LENGTH	SPLICE PLATES	CATALOG NUMBER		UNIT LENGTH
3/4"	1/2"			3/4"	1/2"			3/4"	1/2"	
SUS-14	SUS-14-2	14'	—	SCS-14	14'	—		SH700-A-8	SH700-B-8	4-8'
SUS-13	SUS-13-2	13'	—	SCS-13	13'	—		SH700-A-7	SH700-B-7	4-7'
SUS-12	SUS-12-2	12'	—	SCS-12	12'	—		SH700-A-6	SH700-B-6	4-6'
SUS-11	SUS-11-2	11'	—	SCS-11	11'	—		SH700-A-5	SH700-B-5	4-5'
SUS-10	SUS-10-2	10'	—	SCS-10	10'	—		SH700-A-4	SH700-B-4	4-4'
SUS-9	SUS-9-2	9'	—	SCS-9	9'	—		SH700-A-3	SH700-B-3	4-3'
SUS-8	SUS-8-2	8'	1	SCS-8	8'	1		SH700-A-2	SH700-B-2	4-2'
SUS-7	SUS-7-2	7'	—	SCS-7	7'	—				
SUS-6	SUS-6-2	6'	1	SCS-6	6'	1				
SUS-5	SUS-5-2	5'	1	SCS-5	5'	1				
SUS-4	SUS-4-2	4'	—	SCS-4	4'	—				
SUS-3	SUS-3-2	3'	—	SCS-3	3'	—				
SUS-2	SUS-2-2	2'	—	SCS-2	2'	—				

STANDARD ACCESSORIES

HINGED ACCESSORIES

CATALOG NUMBER	DESCRIPTION	QTY.	CATALOG NUMBER	DESCRIPTION	QTY.	CATALOG NUMBER	DESCRIPTION	QTY.
SEL3	3" End Cap, Left Hand	16	SOP	135° Outside Corner	AO	SPH	Supply Tubing Support Hanger	AO
SER3	3" End Cap, Right Hand	16	SWL3	3" Wall Joiner, Left Hand	12	ST-TUP	Touch-up Spray Paint	6
SBL	6" End Cap, Left Hand	8	SWR3	3" Wall Joiner, Right Hand	12	SSS	Element Expansion Cradle	12
SBR	6" End Cap, Right Hand	8	SAL	6" Wall Joiner, Left Hand	AO			
HEL	4" End Cap, Left Hand	16	SAR	6" Wall Joiner, Right Hand	AO			
HER	4" End Cap, Right Hand	16	SPJ	2" Panel Joiner Set (3 pcs.)	24			
SIC	90° Inside Corner	10	ST-7	7" Telescope Extension Set (3 pcs.)	AO			
SCP	135° Inside Corner	12	ST-14	14" Telescope Extension Set (3 pcs.)	AO			
FIC	Field Adaptable Inside Corner	AO	SSB	Support Bracket & Element Expansion Cradle	AO			
SOC	90° Outside Corner	12	RTH	Return Tubing Hanger	AO			

NOTE: AO = Quantity as Ordered



260 North Elm Street • Westfield, MA 01085 • Tel: (413) 564-5555 • Fax: (413) 572-3764