

Coil-Connect® Kits

Installation, Operation and Maintenance

Introduction

A Coil-Connect® kit is a collection of valves and fittings used to connect and control the primary heat or cooling source within a coil, which is part of a fancoil or air handling unit.

The valves and unions are multi-functional, eliminating the need for additional components, thus saving space.

Some of the components needed can be supplied by NIBCO® in the kit. Additional components, including braided hoses are of a general nature which can also be supplied by NIBCO®, or by others.

The kits are designed to aid the installation of 2-port or 3-port control valves, which are generally specified or supplied by others with female threaded connections.

The kits consist of a combination valve with various features on the supply to the coil, a flow balancing valve and union on the return and various valves or pipes in the bypass.

All products required for coil connection are individually packaged and labelled and each kit is packaged and labelled.

Flexible braided hoses are available from NIBCO® in lengths from 12" to 36"

Coil-Connect® kits can be supplied fully assembled if specified, requiring just 4 connections to be made during field installation.

Kits are available with threaded or solder end valves and fittings.

A full range of drawings are available showing the content of the individual kit and a typical assembly.

Pressure/Temperature Ratings

Check that each component in the kit is suitable for the pressure/temperature rating of the individual circuit/system before commencing installation.

Solder Ends - ASME B16.22

All solder valves and unions in sizes ½" to 2" have the following specific maximum pressure/temperature ratings. Each of the unique individual ratings are listed below and are based on product testing using solder Alloy Sb5 (95-5 tin antimony):

Model	Pressure Rating	Maximum Temperature Rating
S-1800	600 PSI CWP @ 100°F	250°F @ 200 PSI
S-1805	600 PSI CWP @ 100°F	250°F @ 150 PSI
S-1810	300 PSI CWP @ 160°F	260°F @ 150 PSI
S-1820 & S-1830	600 PSI CWP @ 100°F	250°F @ 200 PSI
S-1880	300 PSI CWP @ 160°F	260°F @ 150 PSI

Please Note:

1. The system rated pressure shall be that of the lowest rated fitting, tube or joint, please refer to ASME B16.22 for details.
2. The system pressure/temperature rating varies depending upon the type of solder used when making the joint, please refer to ASME B16.22 for details.

Coil-Connect® Kits

Installation, Operation and Maintenance

Pressure/Temperature Ratings

NPT Threaded Ends - ASME B1.20.1

All threaded valves and unions in sizes ½" to 2" have the following specific minimum and maximum pressure/temperature ratings which are unique to each individual item:

Model	Pressure Rating	Maximum Temperature Rating
T-1800	600 PSI CWP @ 100°F	250°F @ 200 PSI
T-1805	600 PSI CWP @ 100°F	250°F @ 150 PSI
T-1810	300 PSI CWP @ 160°F	260°F @ 150 PSI
T-1820 & T-1830	600 PSI CWP @ 100°F	250°F @ 200 PSI
T-1880 & T-1880SO	300 PSI CWP @ 160°F	260°F @ 150 PSI

Press Ends

All press end valves and unions in sizes ½" to 2" have the following specific minimum and maximum pressure/temperature ratings which are unique to each individual item:

Model	Pressure Rating	Maximum Temperature Rating
PC-1800	200 PSI CWP @ 230°F	250°F @ 150 PSI
PC-1805	200 PSI CWP @ 230°F	250°F @ 150 PSI
PC-1810	200 PSI CWP @ 230°F	250°F @ 150 PSI
PC-1820 & PC-1830	200 PSI CWP @ 230°F	250°F @ 150 PSI
PC-1880 & PC-1880SO	200 PSI CWP @ 230°F	250°F @ 150 PSI

Flexible Braided Hoses

Refer to the submittal drawing or catalog for pressure/temperature rating as these vary with size.

Limits of Use

The valve and union pressure/temperature rating is shown in "Pressure/Temperature Ratings" and they must be installed in a system where the normal pressure and temperature does not exceed this rating.

The valves and unions are intended for non-shock operating conditions.

Water hammer, impacts, stress loads, corrosive or erosive external environmental elements and the transport of fluids with abrasive properties should be avoided.

Layout and Siting

Prior to installation, Coil-Connect® kit location should be considered. Installation location shall allow easy service access for the union nuts, the insertion of a test probes and operation of the drain valve and strainer. It should also be recognised that the connection of a drain hose may be occasionally required.

Coil-Connect® Kits Installation, Operation and Maintenance

Typical Coil-Connect® Kits and Installations

Threaded Kit

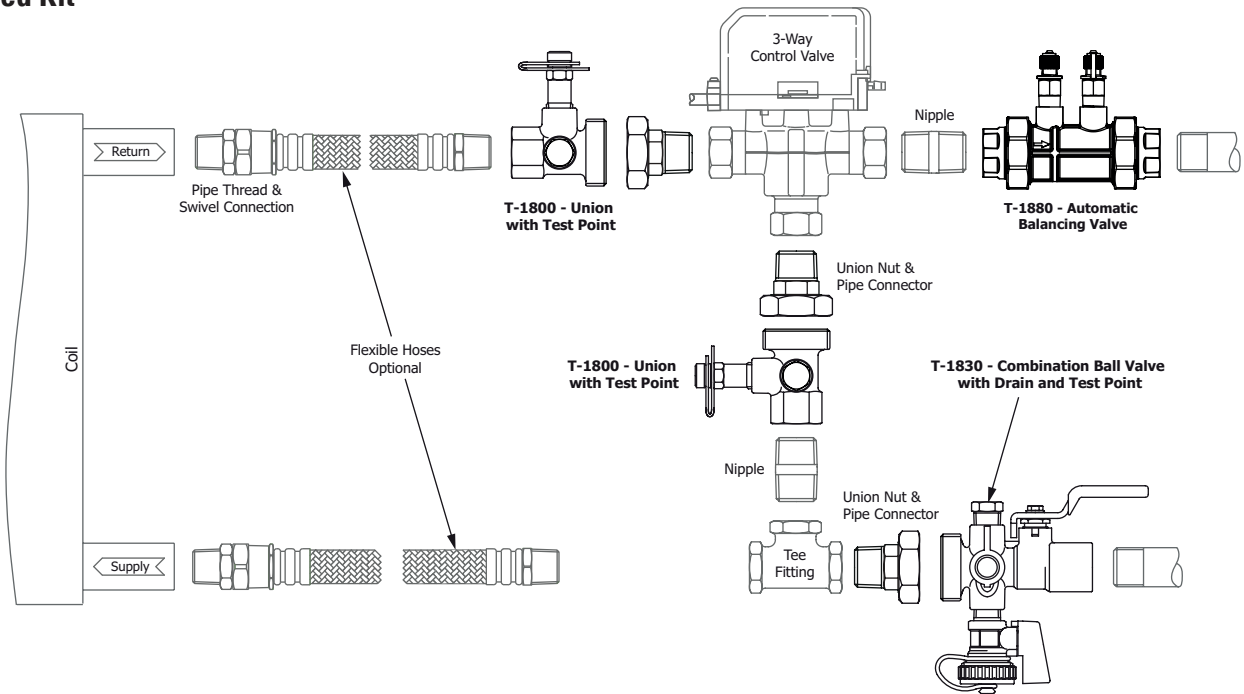

Solder Kit

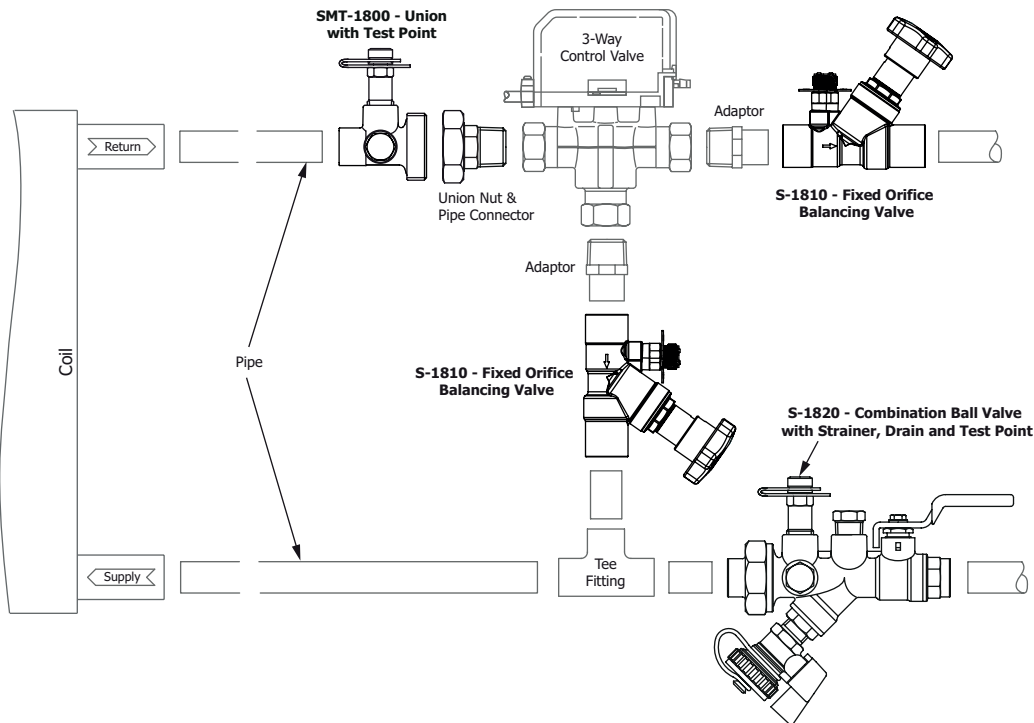

Coil-Connect® Kits

Installation, Operation and Maintenance

Installation - General

The valves and unions are precision manufactured products and should not be subjected to misuse.

The valves and unions should only be unpacked immediately prior to installation to avoid damage or foreign particles entering through the end ports.

Adjacent pipework should be checked for cleanliness and freedom from debris before installation.

Before proceeding with the installation, the union nut and pipe connector must be removed from the body.

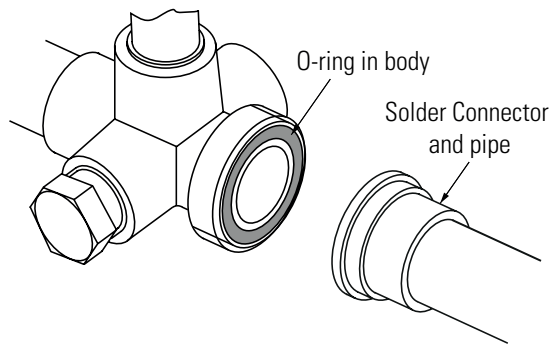

Ensure the body o-ring does not get damaged or lost. Under no circumstances should attempts be made to solder a valve or union into the pipeline without first removing the union nut and solder connector from the body. This connector should be soldered to the tube away from the valve. The warning label on the plastic bag should be read and understood.

When installing threaded valves, thread sealing liquids or tape should be used on the pipe threads but excessive use should be avoided. The use of hemp-style material should be avoided since this may cause over stressing of the female ends of the valve.

When installing press end valves or fittings the end of the copper pipe must be deburred to prevent damage to the O-ring in the press end.

No thread sealing liquids or tape should be used when making the joint.

Make the press joint using the NIBCO® PRESS SYSTEM® TOOL using the correct sized jaws.

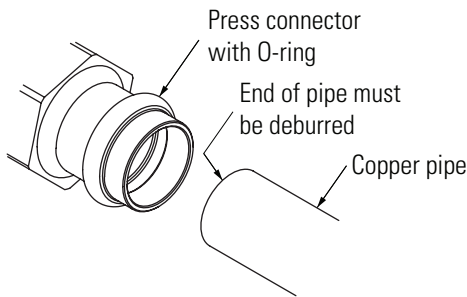

Workmanship

Coil-Connect® kits must be assembled and installed by suitably qualified personnel, using good practices to make the joints and assemble the kits.

A suitable solder and flux must be used to meet local and national regulations.

Remove any burrs from the inside and outside diameter of pipes, tubes and fittings.

Installation

- Remove the pipe connector/union nuts from the valves and unions.
- Assemble the pipe connector/union nut assemblies into the control valves and tee fitting and make water tight joints.
- Assemble the nipples and adaptors into the control valves and flow control valves and make water tight joints.
- Assemble the flexible hoses into the union and tee fitting.

Coil-Connect® Kits

Installation, Operation and Maintenance

Installation

- The flexible hose lengths should be selected to avoid unnecessary bending and twisting.
- For solder connections using copper tube, measure and cut the tube lengths carefully to keep the bypass parallel to the coil.
- Cut the appropriate length of pipe for the bypass to maintain the approximate center distance between the supply and return branches to that of the coil centers.
- Care should be taken when soldering copper tube into the component solder cups.
- Excessive heat should be avoided to prevent damage to the tube or balancing component.

Ensure the body o-ring does not get damaged or lost. Under no circumstances should attempts be made to solder a valve or union into the pipeline without first removing the union nut and solder connector from the body. This connector should be soldered to the tube away from the valve.

- For threaded kits using flexible hoses the distance between the supply and return branches can be kept to a minimum, the flexible hoses overcoming the difference in centers with the coil.
- Assemble and hand tighten all the sub-assemblies together using union connectors ensuring that the body o-ring is in place and the orientation of the valves is with the drain valve vertically down and the valves with strainer and drain have the strainer below the horizontal center line as shown.
- Using a correctly fitting wrench or spanner, further tighten the union nut ¼ turn. Excessive force is not required.
- Using the NIBCO® PRESS SYSTEM® TOOL using the correct sized jaws when making press joints.
- Fit the assembled kit to the coil and supply pipework.

Additional Technical Information

For additional technical information on installation see the individual IOMs supplied with the product or which are available from NIBCO®.

Operation

This IOM is not intended as a guide to system balancing, which should be conducted by a specialist balancing engineer.

The operation of NIBCO® Coil-Connect® valves will be described along with additional functions.

The valves can be supplied with additional pressure test points and manual air vents to aid the balancing process.

The pressure loss through the coil (differential pressure Δp) can be determined by using any pressure test points in the supply and return branches.

The selection of the flow cartridges for the automatic balancing valve should have been made by the system designer, the cartridge should be installed into the body after flushing but prior to system balancing.

Probe Insertion

For safety reasons, all manometer probe insertions of the P/T port must be carried out with the system cold.

Remove the screwed cap and insert the test probe into the P/T port. A silicone oil or grease should be lightly applied to the shaft of the probe before insertion. No other type of lubricant should be used. Always refit the screwed cap.

Coil-Connect® Kits

Installation, Operation and Maintenance

1800 Union

The valve is fitted with a P/T port complete with a blue colored strap and captive cap. For safety reasons, all manometer probe insertions of the P/T port must be carried out with the system cold.



1810 Fixed Orifice Balancing Valve

When used for balancing water distribution systems, the valve will always be in the fully open position at the commencement of any flushing or commissioning procedure.

Regulate the valve by rotating the handwheel clockwise. To close the valve, rotate the handwheel clockwise until a positive stop is felt. Over tightening is not required. To open the valve, rotate the handwheel counter clockwise until a positive stop is felt. Further effort is not necessary. When in the fully open position it is recommended to rotate the handwheel clockwise ½ turn.

During the commissioning stage, all entrained air must be removed from the system before accurate measurements of differential pressure signals can be taken at the P/T ports.

There are two P/T ports, each fitted with a colored strap and captive cap.

- Upstream (HP) Red
- Downstream (LP) Blue

For safety reasons, all manometer probe insertions of the P/T ports must be carried out with the system cold.

Refer to the flow data manual for individual flow charts, Cvs and Cv values.

Valve Setting

Setting of the valve will be displayed by the two figures shown in the windows on the side of the handwheel assembly:

- Window closest to the valve body (Sliding numbers 0-4) illustrates the number of full turns
- Window closest to the handwheel (rotating numbers 0-9) illustrates the tenths of a turn Position 0-0 indicates that the valve is fully closed.

Coil-Connect® Kits

Installation, Operation and Maintenance

1810 Fixed Orifice Balancing Valve Continued

When the required flow has been achieved, the memory stop feature is set as follows:

- Pry open the center handwheel cap using a small screwdriver or similar tool. Insert the 3mm hexagon key provided into the opening and while holding the handwheel in its desired position, tighten the inner hexagon screw clockwise until it stops. Care should be taken not to over tighten this screw.
- Replace the plastic cap. Tampering with the valve setting may be prevented by sealing the cap to the upper part of the handwheel by using the existing slots and an appropriate wire or nylon seals.
- The valve may be fully closed at any time. However when re-opened, it will stop exactly at the previously set point. Opening movement should cease when resistance is felt. Over tightening is not required and should be avoided.

The valve is provided with a data tag that indicates:

- Fig. number of the valve: T-1810 or S-1810
- Nominal size
- Flow coefficient Cvs

On the tag there is room to write the required initial setting of the valve, indicating either the setting reading, the design flow rate or the pressure signal.

This tag can be fixed to the handwheel with the plastic zip tie provided. The plastic tie is long enough to be used with insulated piping systems and still provide a clear identification of the valve.

1805 Fixed Orifice Balancing Valve

When used for balancing water distribution systems, the valve will always be in the fully open position at the commencement of any flushing or commissioning procedure.

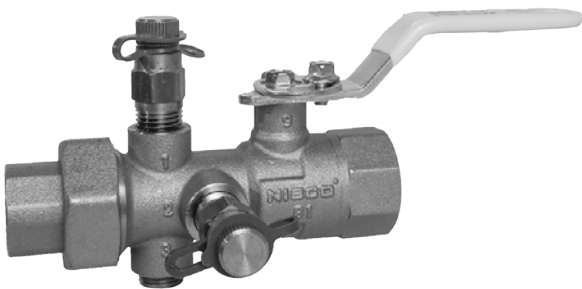

Regulate the valve by rotating the lever clockwise. To close the valve, rotate the lever clockwise until the lever contacts the stop lug on the body; attempting to rotate the lever beyond this point will not improve the sealing capabilities of the valve and may cause damage.

To open the valve, rotate the lever counter clockwise until the lever contacts the stop lug on the body.

During the commissioning stage, all entrained air must be removed from the system before accurate measurements of differential pressure signals can be taken at the P/T ports.

During the commissioning stage, all entrained air must be removed from the system before accurate measurements of differential pressure signals can be taken at the P/T ports.

Coil-Connect® Kits

Installation, Operation and Maintenance

1805 Fixed Orifice Balancing Valve Continued

There are two P/T ports, each fitted with a colored strap and captive cap.

- Upstream (HP) Red
- Downstream (LP) Blue

For safety reasons, all manometer probe insertions of the P/T ports must be carried out with the system cold.

Refer to the flow data manual for individual flow charts, Cvs and Cv values.

Valve Setting

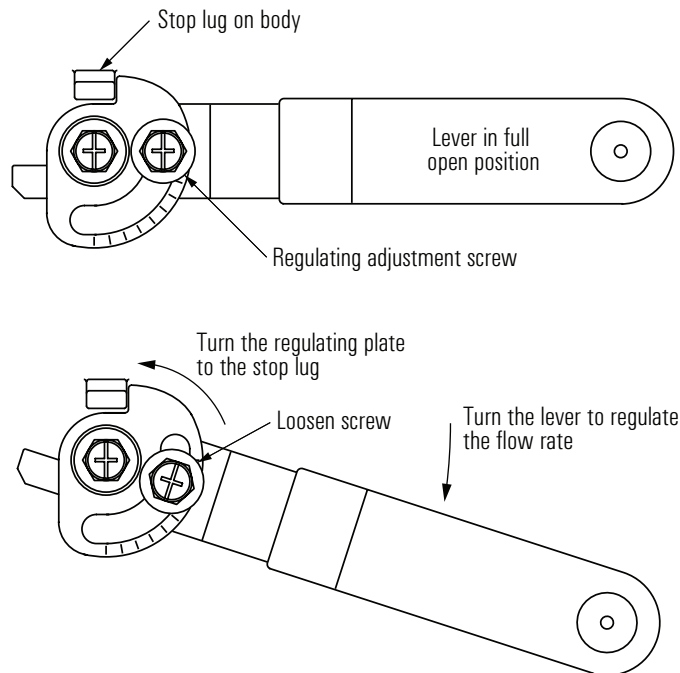

The regulating plate rotates around the lever retaining screw and is fixed to the lever by the regulating adjustment screw.

- The approximate position open is indicated by the incremental markings on the regulating plate.
- To regulate the flow loosen the regulating adjustment screw and turn the lever to the required position.
- The flow is determined by measuring the signal across the venturi using the red and blue PT ports and converting the signal to a flow rate using the flow charts available from NIBCO®.
- Slowly close the valve whilst reading the differential pressure gauge or manometer until the desired flow rate is achieved.
- The valve may be fully closed at any time. However when re-opened, it will stop exactly at the previously set point. Opening movement should cease when the stop lug is contacted.

Coil-Connect® Kits

Installation, Operation and Maintenance

1805 Fixed Orifice Balancing Valve Continued

Valve Setting

When the required flow has been achieved, the memory stop feature is set as follows:

- Without disturbing the lever position, carefully rotate the regulating plate counter clockwise until it contacts the stop lug on the body.
- Fully re-tighten the regulating adjustment screw.
- Operate the valve to the fully closed position and re-open to the set position to check the operation and setting.

NOTE: excessive force is not required and should be avoided when setting the valve in the regulated position. Cease turning the lever when a positive stop is felt.

1820 Combination Ball Valve with Strainer

The valve is opened and closed by operating the lever through 90° to a positive stop. Excessive force is not required. The open position is with the lever in line with the pipeline.

The valve is fitted with a P/T port complete with a blue colored strap and captive cap. For safety reasons, all manometer probe insertions of the P/T port must be carried out with the system cold.



The valve is provided with a drain valve, which after installation should be vertically below the main valve and at its lowest point. This is a 90° operation ball valve providing positive isolation. The drain valve should always be set in the closed position – this is when the small lever is at 90° to the axis of the valve.

Ensure eye protection and gloves are worn before commencing any draining work.

The drain valve can also be used as a blow down valve. With the valve in the closed position and the cap removed the valve may be opened and the pressure in the system will flush out debris within the strainer screen.

When any draining or flushing is to be carried out, always ensure the drain valve is in the closed position before the cap is removed. It is recommended that a suitable female threaded fitting attached to a hose is available which should be screwed onto the drain valve and a suitable receptacle or draining location used for collecting or directing the flush or drained water.

Always refit the screwed cap to the drain valve.

Coil-Connect® Kits

Installation, Operation and Maintenance

1830 Combination Ball Valve with Drain

The valve is opened and closed by operating the lever through 90° to a positive stop. Excessive force is not required. The open position is with the lever in line with the pipeline.

The valve is fitted with a P/T port complete with a blue colored strap and captive cap. For safety reasons, all manometer probe insertions of the P/T port must be carried out with the system cold.



A drain valve is provided and after installation the drain valve should be vertically below the main valve. This is a 90° operation ball valve providing positive isolation. The drain valve should always be set in the closed position – this is when the small lever is at 90° to the axis of the valve.

Ensure eye protection and gloves are worn before commencing any draining work.

When any draining is to be carried out, always ensure the drain valve is in the closed position before the cap is removed. It is recommended that a suitable female threaded fitting attached to a hose is available which should be screwed onto the drain valve and a suitable receptacle or draining location used for collecting or directing the drained water.

Always refit the screwed cap to the drain valve.

1880 Automatic Balancing Valve

There is nothing to operate with the 1880 Automatic balancing valve.

The system should be flushed without the cartridge fitted, the last thing to do before the system is balanced is fit the cartridge and identification tag.

Fitting the Cartridge

The flow cartridge is supplied separately in a box. Check that the flow data shown on the box label corresponds with the flow requirement of the ABV in the particular location.

Ensure the system is de-pressurized and drained.

Disconnect the union nuts and remove the valve body.



Open the cartridge box and remove the cartridge, spring retainer and data label. Confirm that the data label corresponds to the box label.

Coil-Connect® Kits

Installation, Operation and Maintenance

1880 Automatic Balancing Valve Continued

Fitting the Cartridge



Insert the fixed housing end of the cartridge into the valve body in the direction of the flow arrow and press fully into position.

It should be possible to manually depress the spring loaded piston when in position.

Insert the spring clip into the body so the square corners of the spring click into the groove.

Apply the adhesive data label to the metal tag.

Check that the body o-rings are in place and re-install the body to the pipework ensuring the direction arrow on the body coincides with the direction of flow.

T-1880SO Automatic Balancing Valve with Ball Valve

The T-1880SO is a T-1880 automatic balancing valve connected to a ball valve for isolation

Maintenance

The 1800 union, 1810 balancing valve, 1805 balancing valve, 1830 combination valve and the 1880 automatic balancing valve should not require any regular maintenance.

The 1820 combination valve with strainer and drain valve should have the screen in the strainer checked and cleaned periodically using the drain valve to flush any debris from the screen.

If the flushing operation fails to clear the strainer screen satisfactorily, it may be necessary to occasionally remove the strainer screen for cleaning.

Close the combination valve and the nearest downstream valve and drain that part of the system until water flow has stopped. Using a correctly sized spanner or wrench remove the cap from the body (there is no need to separately remove the drain valve).

The strainer screen may come out with the cap otherwise, carefully withdraw the strainer screen from the body.

The screen may be washed in a container of water or subjected to a jet of water.

Coil-Connect® Kits

Installation, Operation and Maintenance

Notes: