



UA17

Parts List
07-September-2017



*This parts list is current as of the above revision date.
See <http://www.rheempartslists.net/92-42801-UA17.pdf> for the current revision.*

Condensing Units

Table of Contents

Model Explanation	Page 3
Parts Numbers	
Panels	Page 4
Electrical-Fan Group	Page 5
Coil Parts	Page 6
Compressor Group	Page 7
Accessories	Page 8
Drawings/Photographs	
Exploded View	Page 9
Control Box (1)	Page 10
Control Box (2)	Page 10
Valve Mounting, Compressor	Page 11
Notes	Page 12

MODEL NUMBER EXPLANATION

U	A	1	7	1	8	A	J	2	C	B
1	2	3		4		5	6	7	8	9

- | | |
|--------------------------------------------------------------------------------------------------------------------------------------------------------------------------------------------------------------------------------------------------------------------------------------------------------------------------|----------------------------------------------------------------------------------------------------------------------------------------------------------------------------------------------------------------------------------------------------------------------------------------------------------------------------------------------------------------------------------------|
| <p>(1) Brand
R = Rheem
U = Ruud</p> <p>(2) Product Category
A = Air Conditioner</p> <p>(3) Seer
17 = 17 SEER</p> <p>(4) COOLING CAPACITY (BTU/HR)
018 = 18,000
024 = 24,000
030 = 30,000
036 = 36,000
042 = 42,000
048 = 48,000
060 = 60,000</p> | <p>(5) MAJOR SERIES
A = First Design Series</p> <p>(6) VOLTAGE
J = 208-230/1/60
C = 208-230/3/60
D = 460/3/60
Y = 575/3/60</p> <p>(7) TYPE
2 = Two Stage</p> <p>(8) CONTROLS
C = Communicating
N = Non-Communicating</p> <p>(9) MINOR SERIES
A = First Design Series
B = Second Design Series (LPC/HPC)</p> |
|--------------------------------------------------------------------------------------------------------------------------------------------------------------------------------------------------------------------------------------------------------------------------------------------------------------------------|----------------------------------------------------------------------------------------------------------------------------------------------------------------------------------------------------------------------------------------------------------------------------------------------------------------------------------------------------------------------------------------|

SERIAL NUMBER EXPLANATION

W	0	8	1	3	9	9	9	9
(1)	(2)		(3)		(4)			

- (1) **PLANT CODE**
W = West Nuevo Laredo
- (2) **WEEK OF PRODUCTION**
- (3) **YEAR OF PRODUCTION**
- (4) **PRODUCTION NUMBER**

Note: For Compressor Identification Number, see Compressor Code on Rating Plate

No.	Notes	MODEL COOLING CAPACITY VARIATION	UA17 24 AJ2CB	UA17 36 AJ2CB	UA17 48 AJ2CB	UA17 60 AJ2CB
SHEET METAL PARTS, MISCELLANEOUS						
1		Front Panel	AE-104456-25	AE-104456-28	AE-104456-49	AE-104456-49
2		Left Panel (Badge Panel)	AE-104456-41	AE-104456-42	AE-104456-58	AE-104456-58
		Badge	91-105392-02	91-105392-02	91-105392-02	91-105392-02
		Left Panel Louver Label	91-104695-01	91-104695-01	91-104696-01	91-104696-01
3		Back Panel	AE-104456-26	AE-104456-29	AE-104456-50	AE-104456-50
4		Right Panel	AE-104456-25	AE-104456-28	AE-104456-49	AE-104456-49
5		Base Pan	68-104457-02	68-104457-02	68-104457-03	68-104457-03
6		Control Box (Before W1017)	AE-104461-01	AE-104461-01	AE-104461-01	AE-104461-01
6		Control Box (On or After W1017)	10-106433-01	10-106433-01	10-106433-01	10-106433-01
7		Control Box Cover (Before W1017)	AS-104462-01H	AS-104462-01H	AS-104462-01H	AS-104462-01H
7		Control Box Cover (On or After W1017)	AS-104462-02H	AS-104462-02H	AS-104462-02H	AS-104462-02H
8		Control Box Bracket (Before W1017)	AS-104460-04H	AS-104460-05H	AS-104460-11H	AS-104460-11H
8		Control Box Bracket (On or After W1017)	AS-104460-14H	AS-104460-15H	AS-104460-16H	AS-104460-16H
9		Service Door	AS-104525-01H	AS-104525-01H	AS-104525-01H	AS-104525-01H
10		Center Post (2)	AS-104459-07H	AS-104459-09H	AS-104459-13H	AS-104459-13H
11		Corner Post	AS-104469-04H (2)	AS-104469-05H (2)	AS-104469-07H (2)	AS-104469-07H (2)
12		Corner Post	AS-104469-04H (1)	AS-104469-05H (1)	AS-104469-07H (1)	AS-104469-07H (1)
13		Top Panel (Black)	AS-104458-02J	AS-104458-02J	AS-104458-03J	AS-104458-03J
14		Venturi	68-104464-06	68-104464-04	68-104464-07	68-104464-07
15		Grille (before W3817)	95-104620-02	95-104620-02	95-104620-03	95-104620-03
15		Grille (on or after W3817)	95-104620-02	95-104620-02	95-104620-04	95-104620-04
		Center Cap - Blank (for Grille, before W3817)	91-101123-00	91-101123-00	91-101123-00	91-101123-00
		Center Cap - Blank (for Grille, on or after W3817)	91-101123-00	91-101123-00	91-106416-00	91-106416-00
		Center Cap (for Grille, before W3817)	91-101123-22	91-101123-22	91-101123-22	91-101123-22
		Center Cap (for Grille, on or after W3817)	91-101123-22	91-101123-22	91-101123-32	91-101123-32
		Service Valve - Suction	See Coil Group			
		Service Valve - Liquid	See Coil Group			
		Touch-up Paint - Granite/Steel Gray (Aerosol)	PD523018	PD523018	PD523018	PD523018
		Touch-up Paint - Granite/Steel Gray (Paint Pens)	PD523019	PD523019	PD523019	PD523019
		Touch-up Paint - Ruud Black (Aerosol)	PD523201	PD523201	PD523201	PD523201
		Touch-up Paint - Ruud Black (Paint Pens)	PD523202	PD523202	PD523202	PD523202

No.	Notes	MODEL COOLING CAPACITY VARIATION	UA17 24 AJ2CB	UA17 36 AJ2CB	UA17 48 AJ2CB	UA17 60 AJ2CB
ELECTRICAL/FAN GROUP						
20	Stk	Fan Motor (Before W1017)	51-102870-05	51-101774-03	51-105035-01	51-105035-01
20	Stk	Fan Motor (On or After W1017)	51-102870-09	51-101774-40	51-105035-01	51-105035-01
21	Stk	Fan Blade	70-102345-08	70-102345-01	70-102345-09	70-102345-09
22	Stk	Contactora	42-102664-05	42-102664-05	42-102664-10	42-102664-10
23		Capacitor	See Compressor Group			
23a		Capacitor Strap	AE-104562-01	AE-104562-01	AE-104562-01	AE-104562-01
25		Crankcase Heater	See Compressor Group			
26		Grounding Lug	45-19000-01	45-19000-01	45-19000-01	45-19000-01
		Low Ambient Control	See Accessories Group			
27	Stk	Low Pressure Control	47-103670-02	47-103670-02	47-103670-04	47-103670-04
27a		Valve Body - Low Pressure Control	61-18542-01	61-18542-01	61-18542-01	61-18542-01
28	Stk	High Pressure Control	47-102290-01	47-102290-01	47-102290-01	47-102290-01
		Wiring Harness - Thermostat (Before W0117)	45-101891-08	45-101891-08	45-101891-08	45-101891-08
		Wiring Harness - Thermostat (On or After W0117)	45-101891-11	45-101891-11	45-101891-11	45-101891-11
		Locking Push Mount Tie (for securing thermostat wires)	64-25340-02	64-25340-02	64-25340-02	64-25340-02
		Control - Identity EEPROM	47-102738-105	47-102738-106	47-102738-107	47-102738-108
		Ambient Sensor	47-102709-06	47-102709-06	47-102709-06	47-102709-06
29		Control Board - EcoNet	47-105395-01	47-105395-01	47-105395-01	47-105395-01
		Compressor Wiring Harness (Low Voltage)	See Compressor Group			
		Compressor Plug Harness	See Compressor Group			

No.	Notes	MODEL COOLING CAPACITY VARIATION	UA17 24 AJ2CB	UA17 36 AJ2CB	UA17 48 AJ2CB	UA17 60 AJ2CB
COIL GROUP						
30	Stk	Condenser Coil	AS-105394-03	AS-105419-03	AS-105427-03	AS-105427-03
31		Service Valve - Suction	61-104914-03	61-104914-03	61-104914-04	61-104914-04
32		Service Valve - Liquid	61-104914-01	61-104914-01	61-104914-01	61-104914-01
33a		Valve Core	61-18551-01	61-18551-01	61-18551-01	61-18551-01
33b		Valve Cap	83-100635-01	83-100635-01	83-100635-01	83-100635-01
27	Stk	Low Pressure Control	See Electrical Group			
28	Stk	High Pressure Control	See Electrical Group			
	Stk	Filter Drier	83-22755-06	83-22755-06	83-22755-06	83-22755-06

No.	Notes	MODEL COOLING CAPACITY VARIATION	UA17 24 AJ2CB	UA17 36 AJ2CB
COMPRESSOR GROUP				
		Compressor ID:	9081	9082
40	Stk	Compressor	55-23156-35S	55-23156-36S
		Compressor Grommet (4)	56-18518-04	56-18518-04
		Compressor Bolt (4)	63-20072-07	63-20072-07
23	Stk	Capacitor - Compressor/Fan	43-101666-23	43-101665-36
	1	Compressor Plug Harness - includes Current Sensing Transformer (CT), See Note 1	45-100834-14	45-100834-14
	Stk	Compressor Wiring Harness (Low Voltage - Molded Plug) - Before W0117	45-101723-05	45-101723-05
	Stk	Compressor Wiring Harness (Low Voltage - Molded Plug) - On or After W0117	45-101723-05	45-101723-07
25		Crankcase Heater	N/A	44-103663-13
		Filter Drier	See Coil Group	

No.	Notes	MODEL COOLING CAPACITY VARIATION	UA17 48 AJ2CB	UA17 60 AJ2CB
COMPRESSOR GROUP				
		Compressor ID:	9083	9084
40	Stk	Compressor	55-23156-37S	55-23156-34S
		Compressor Grommet (4)	56-18518-06	56-18518-06
		Compressor Bolt (4)	63-20072-07	63-20072-07
23	Stk	Capacitor - Compressor/Fan	43-101666-66	43-101666-25
	1	Compressor Plug Harness - includes Current Sensing Transformer (CT), See Note 1	45-100834-15	45-100834-15
	Stk	Compressor Wiring Harness (Low Voltage - Molded Plug)	45-101723-05	45-101723-05
25		Crankcase Heater	44-103663-13	44-103663-13
		Filter Drier	See Coil Group	

No.	Notes	MODEL COOLING CAPACITY VARIATION	UA17 24 AJ2CB	UA17 36 AJ2CB	UA17 48 AJ2CB	UA17 60 AJ2CB
ACCESSORIES						
		Low Ambient Control	RXAD-A08	RXAD-A08	RXAD-A08	RXAD-A08
		Heat Pump Riser	686020	686020	686020	686020
		Compressor Crankcase Heater	44-17402-49	44-17402-49	44-101884-05	44-101884-05
		Compressor Sound Cover	68-23427-26	68-23427-26	68-25217-10	68-25217-10
		Compressor Hard Start Kit	SK-A1	SK-A1	SK-A1	SK-A1

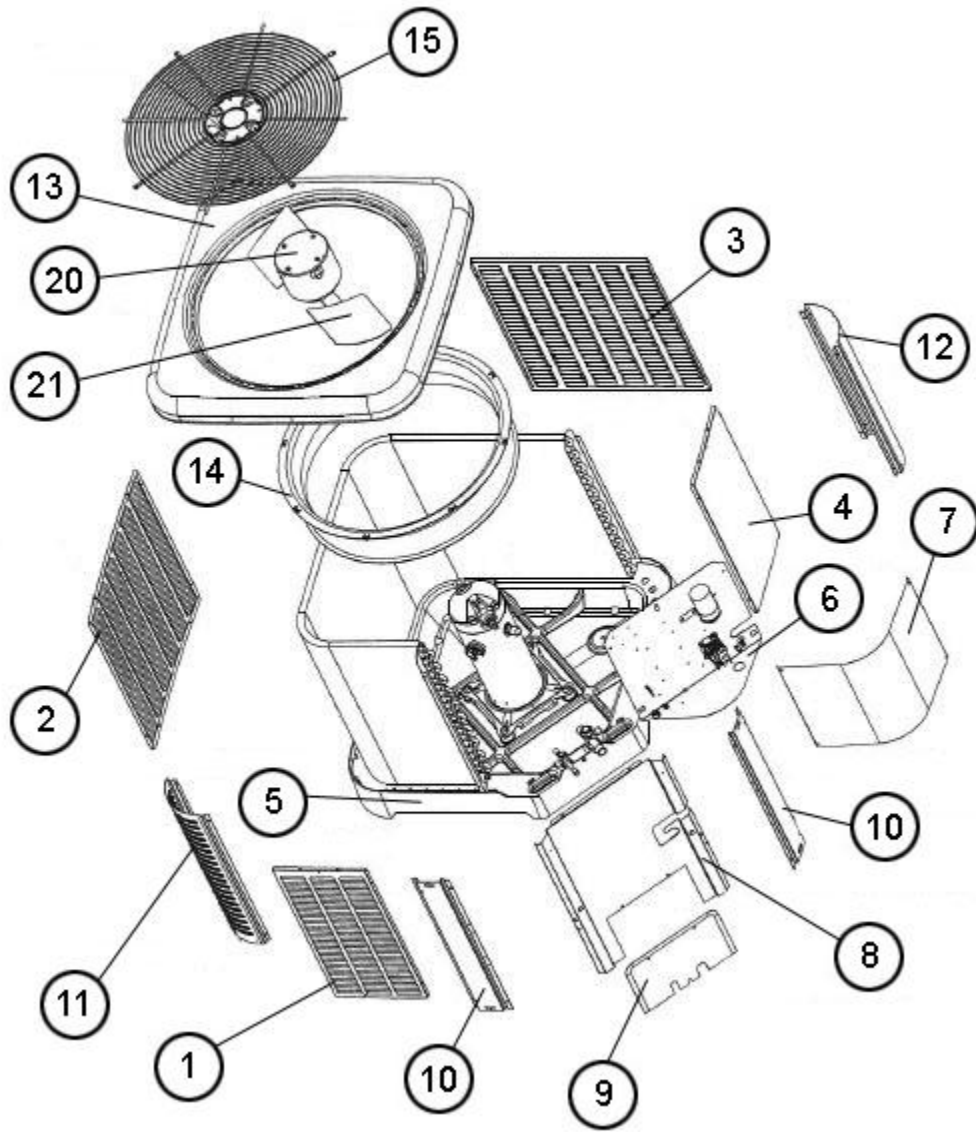

Exploded View

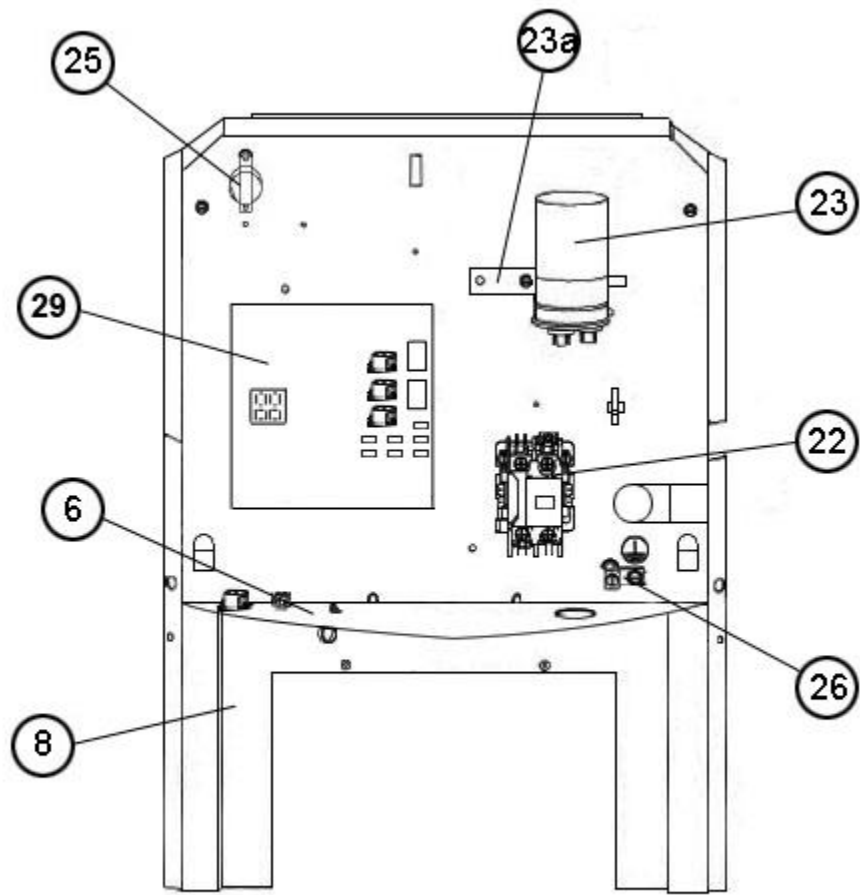

Control Box (1)

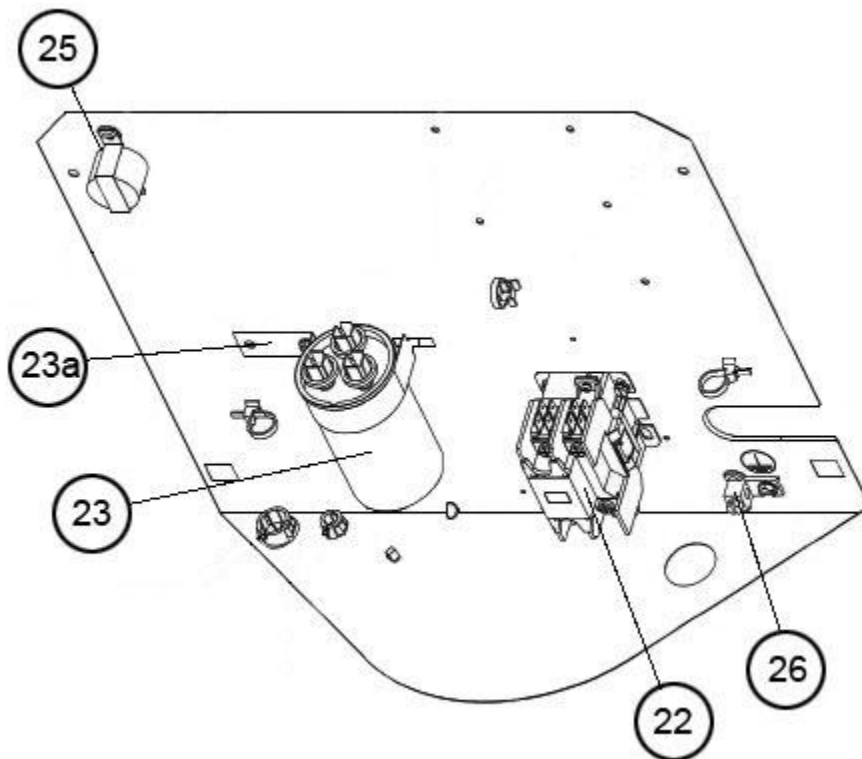

Control Box (2)

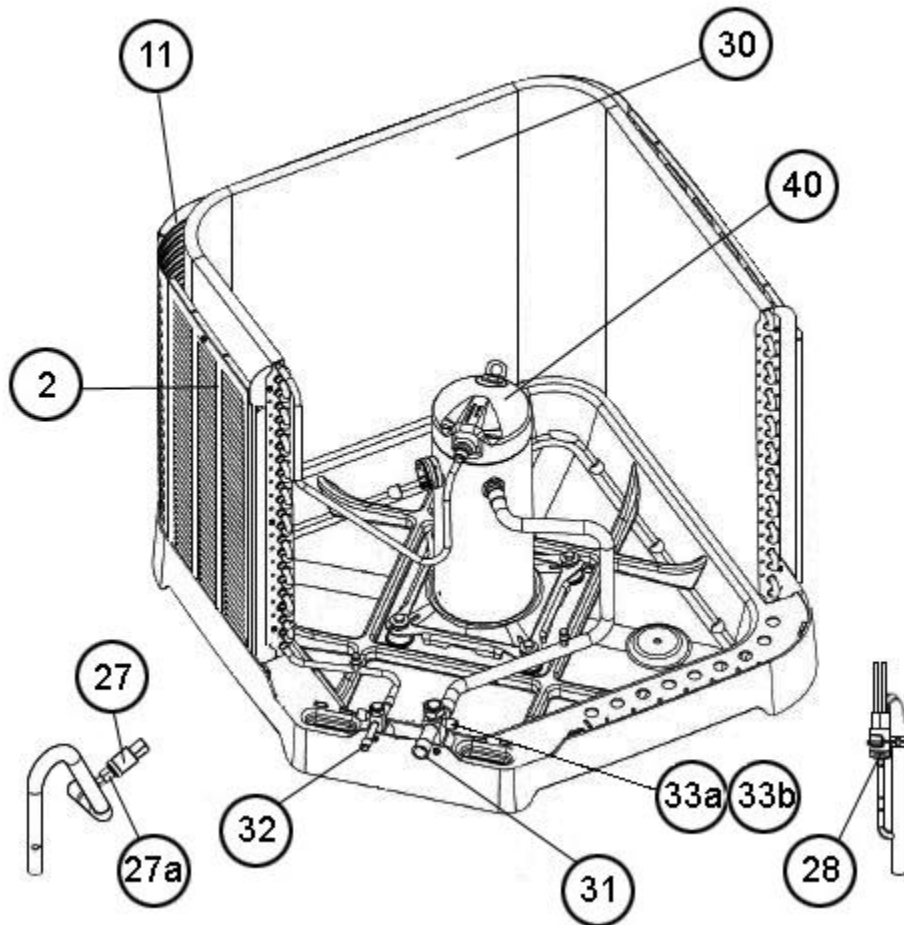

Valve Mounting, Compressor

NOTES

Stk It is recommended that stock be maintained for this part.

N/A Not Applicable

- 1 The Current Sensing Transformer (CT) is integral with the Compressor Plug Harness. To replace a defective CT, order the Compressor Plug Harness.