

Product information presented here reflects conditions at time of publication. Consult factory regarding discrepancies or inconsistencies.



MAIL TO: P.O. BOX 16347 • Louisville, KY 40256-0347
SHIP TO: 3649 Cane Run Road • Louisville, KY 40211-1961
TEL: (502) 778-2731 • 1 (800) 928-PUMP • FAX: (502) 774-3624

Visit our web site:
zoellerpumps.com

REPLACEMENT PARTS LIST FOR MODELS:

M53 AUTOMATIC 115V
D53 AUTOMATIC 230V
N53 NONAUTOMATIC 115V
E53 NONAUTOMATIC 230V

Consult factory for all other models.

TO ORDER REPLACEMENT PARTS:
PLEASE FURNISH THE FOLLOWING INFORMATION:

- Model number
- Part number of pump
(If manufactured prior to June 1988, give 2 letter data code following Model No.)
- Part number and description of part

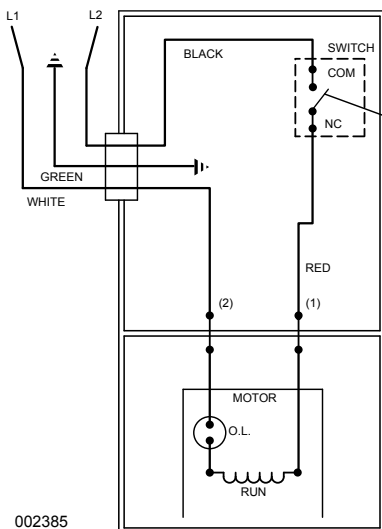

WIRING DIAGRAM FOR MODELS
"M53-A" and "D53-A"
9/81 (VM) thru 8/86 (US)

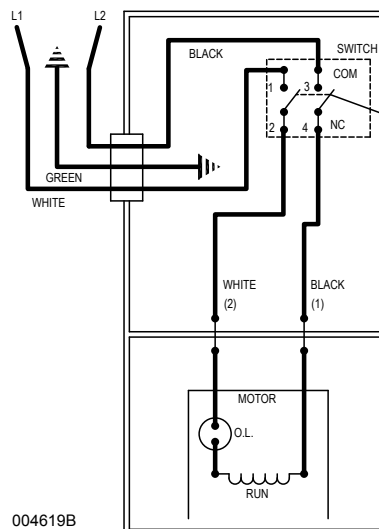

WIRING DIAGRAM FOR MODELS
"M53-B", "M53-C" and "M53-D"
"D53-B", "D53-C", and "D53-D"
9/86 (VS) thru Current

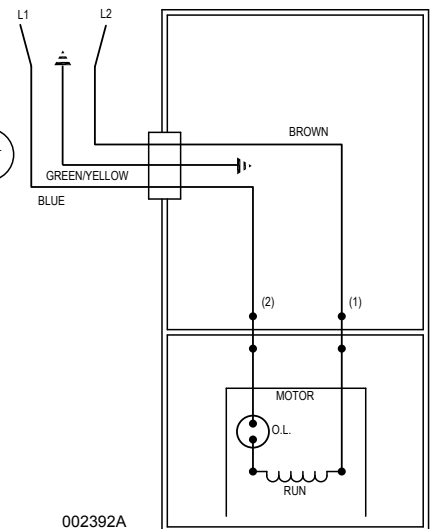

WIRING DIAGRAM FOR MODELS
"N53-A", "N53-B" and "N53-C"
"E53-A", "E53-B", and "E53-C"
9/81 (VM) thru Current

REPLACEMENT PARTS LIST FOR MODELS "M53" and "D53".

See back page for illustration.

		MODELS:		M53-A	M53-B	M53-C	M53-D	D53-A	D53-B	D53-C	D53-D
REF NO.	DESCRIPTION	QTY	NOTES	9/81 VM thru 8/86 US	9/86 VS thru 8/87 UT	9/87 VT thru 6/92	7/92 thru Current	9/81 VM thru 8/86 US	9/86 VS thru 8/87 UT	9/87 VT thru 6/92	7/92 thru Current
1	• Gasket, Case/Cover	1		034046	034046	034046	034046	034046	034046	034046	034046
2	• Clamp, Strain Relief-Red	1		004200	004200	004200	004200	004200	004200	004200	004200
3	• Seal, Cord-Asm "60"	1		002326	004322	004322	004322	002326	004322	004322	004322
4	Cord Term & Seal 115V/A	1	1,3	002321	004700	004700	004700	002320	004707	004707	004707
5	Stator Regal-Beloit	1	2	054040	054040	054040	007951	N/A	N/A	N/A	007952
	Stator 115V/1Ph Emerson			N/A	N/A	N/A	012095	N/A	N/A	N/A	012096
6	• Screw, #8-32 X 2.563 RHPI-Stlbo	2		001914	001914	001914	001914	001914	001914	001914	001914
7	Rotor Asm Regal-Beloit	1	2	054032	054032	054032	054032	054032	054032	054032	054032
	Rotor Asm 115/230V/1Ph Emerson			N/A	N/A	N/A	012095	N/A	N/A	N/A	012096
8	• Seal, Mtr Hsg	1		034007	034007	034007	034007	034007	034007	034007	034007
9	• Washer, Trst-Nyl.875X.504X.050"	1		002140	002140	002140	002140	002140	002140	002140	002140
10	• Oil, Dielectric-(19 Oz Can)	1		002588	002588	002588	002588	002588	002588	002588	002588
11	Housing, Pump-Mach	1		057018	057018	057018	057018	057018	057018	057018	057018
12	• Seal Asm, Shaft-Blister Pak	1		267027	267027	267027	267027	267027	267027	267027	267027
13	Impeller-Plas 53	1		003644	003644	003644	003644	003644	003644	003644	003644
14	Base Asm	1		002690	002690	002690	002690	002690	002690	002690	002690
15	Plate, Strainer-Plastic	1		001082	001082	N/A	N/A	001082	001082	N/A	N/A
16	Case Handle & Arm Asm "50"	1	3,6	054092	004703	004703	004703	054093	004703	004703	004703
17	• Plug, Test-White	2		034090	034090	034090	034090	034090	034090	034090	034090
18	• Arm & Seal Asm "50"	1	3	054080	004704	004704	004704	054080	004704	004704	004704
19	Case & Switch "50"	1	3,6,7	054051	004702	004702	004702	054053	004702	004702	004702
20	Guard "50/1050"	1	3	034016	004645	004645	004645	034016	004645	004645	004645
21	• Seal, Thru Wall Term	2		003402	003402	003402	003402	003402	003402	003402	003402
22	Housing, Mtr-& Term Asm "50"	1		003177	004712	004712	004712	003177	004712	004712	004712
23	Float-Polypropylene	1		034019	034019	034019	034019	034019	034019	034019	034019
24	Rod Asm, Fit	1		054062	054062	054062	054062	054062	054062	054062	054062
25	Guide Asm, Fit Rod	1		034086	034086	034086	034086	034086	034086	034086	034086
26	Switch Asm "50"	1	3	034061	004705	004705	004705	034061	004705	004705	004705
▫	Wire Asm-F-P(1)Wire Rs2.25"Lg	1		002231	N/A	N/A	N/A	002231	N/A	N/A	N/A
27	• Screw, #10-24 X.75 RHM-SI SS	16		001885	001885	001885	001885	001885	001885	001885	001885
28	• Screw, #6-32x.438Rhsltp"1"Stlzi	2		001877	004644	004644	004644	001877	004644	004644	004644
29	• Screw, #6-32x.25RHM SI Tc Stlgr	1		001877	001877	001877	001877	001877	001877	001877	001877
30	• Sem, 10-12x.5HH-SIShmt Scr Tp A	3		003229	003229	N/A	N/A	003229	003229	N/A	N/A
▫	Rebuild Kit "53/1053/55"	1		003181	004706	004706	004706	003181	004706	004706	004706

• Items included in Rebuild Kit.

▫ Not Shown in Illustration.

§ Not sold separately.

NOTES:

- 1) Strain Relief (Item 2) can be purchased separately, but is included with Cord, Terminal & Seal Assembly (Item 4) and with Seal, Cord Assembly (Item 3).
- 2) Emerson stators (identified by green epoxy insulation) are no longer available. A stator and rotor combination by Regal-Beloit who took over the GE line of motors must be purchased to replace the individual Emerson stator or rotor for date code 7/92 to current. Emerson motors replacement prior to 7/92 is no longer available. 230 volt stators for Emerson and Regal-Beloit are no longer available prior to 7/92.
- 3) To insure proper replacement, customer must identify if switch is a General Electric switch.
- 4) See FM0160 Parts Price Sheet for listing of parts prices.
- 5) "NA" indicates, not applicable.
- 6) If an "X" follows Model No., or Date Mfg. on ID tag, consult factory for ordering any parts.
- 7) For pumps with date code prior to 9/86 the replacement case and switch will have a new style switch.

REPLACEMENT PARTS LIST FOR MODELS "N53" and "E53".

See back page for illustration.

MODELS:				N53	N53-A	N53-B	N53-C	E53	E53-A	E53-B	E53-C
REF NO.	DESCRIPTION	QTY	NOTES	9/81 VM thru 8/86 US	9/86 VS thru 8/87 UT	9/87 VT thru 6/92	7/92 thru Current	9/81 VM thru 8/86 US	9/86 VS thru 8/87 UT	9/87 VT thru 6/92	7/92 thru Current
1	• Gasket,Case/Cover	1		034046	034046	034046	034046	034046	034046	034046	034046
2	• Clamp,Strain Relief-Red	1	1	004200	004200	004200	004200	004200	004200	004200	004200
3	• Seal,Cord-Asm "60"	1	1,3	002326	004322	004322	004322	002326	004322	004322	004322
4	Cord Term & Seal 115V/Na	1	1	002319	004708	004708	004708	002318	004709	004709	004709
5	Stator Regal-Beloit	1	2	054040	054040	054040	007951	N/A	N/A	N/A	007952
	Stator 115V/1Ph Emerson	1	2	N/A	N/A	N/A	012095	N/A	N/A	N/A	012096
6	• Screw,#8-32 X 2.563 RHPI-Stlbo	2		001914	001914	001914	001914	001914	001914	001914	001914
7	Rotor Asm Regal-Beloit	1	2	054032	054032	054032	054032	054032	054032	054032	054032
	Rotor Asm 115/230V/1Ph Emerson	1	2	N/A	N/A	N/A	012095	N/A	N/A	N/A	012096
8	• Seal,Mtr Hsg	1		034007	034007	034007	034007	034007	034007	034007	034007
9	• Washer,Trst-Nyl.875X.504X.050"	1		002140	002140	002140	002140	002140	002140	002140	002140
10	• Oil,Dielectric-(19 Oz Can)	1		002588	002588	002588	002588	002588	002588	002588	002588
11	Housing,Pump-Mach	1		057018	057018	057018	057018	057018	057018	057018	057018
12	• Seal Asm,Shaft-Blister Pak	1		267027	267027	267027	267027	267027	267027	267027	267027
13	Impeller-Plas 53	1		003644	003644	003644	003644	003644	003644	003644	003644
14	Base Asm	1		002690	002690	002690	002690	002690	002690	002690	002690
15	Plate,Strainer-Plastic	1		001082	001082	N/A	N/A	001082	001082	N/A	N/A
16	Cover & Handle "50"	1		034067	034067	034067	034067	034067	034067	034067	034067
17	• Plug,Test-White	2		034090	034090	034090	034090	034090	034090	034090	034090
18	• Seal,Thru Wall Term	2		003402	003402	003402	003402	003402	003402	003402	003402
19	Housing,Mtr-& Term Asm "50"	1		003177	004712	004712	004712	003177	004712	004712	004712
20	• Screw,#10-24 X.75 RHM-SI SS	16		001885	001885	001885	001885	001885	001885	001885	001885
21	• Sem,10-12x.5HH-SIShtmt Scr Tp A	3		003229	003229	N/A	N/A	003229	003229	N/A	N/A
22	• Screw,#6-32x.25RHM SI Tc Stlgr	1		001877	001877	001877	001877	001877	001877	001877	001877
⌘	Rebuild Kit "53/1053/55"	1		003181	004706	004706	004706	003181	004706	004706	004706

• Items included in Rebuild Kit.

⌘ Not Shown in Illustration.

§ Not sold separately.

NOTES:

- 1) Strain Relief (Item 2) can be purchased separately, but is included with Cord, Terminal & Seal Assembly (Item 4) and with Seal, Cord Assembly (Item 3).
- 2) Emerson stators (identified by green epoxy insulation) are no longer available. A stator and rotor combination by Regal-Beloit who took over the GE line of motors must be purchased to replace the individual Emerson stator or rotor for date code 7/92 to current. Emerson motors replacement prior to 7/92 is no longer available. 230 volt stators for Emerson and Regal-Beloit are no longer available prior to 7/92.
- 3) When ordering these parts, customer must identify if switch is a General Electric switch.
- 4) See FM0160 Parts Price Sheet for listing of parts prices.
- 5) "NA" indicates, not applicable.
- 6) If an "X" follows Model No., or Date Mfg. on ID tag, consult factory for ordering any parts.

REPLACEMENT PARTS ILLUSTRATION FOR MODELS "M53" AND "D53"

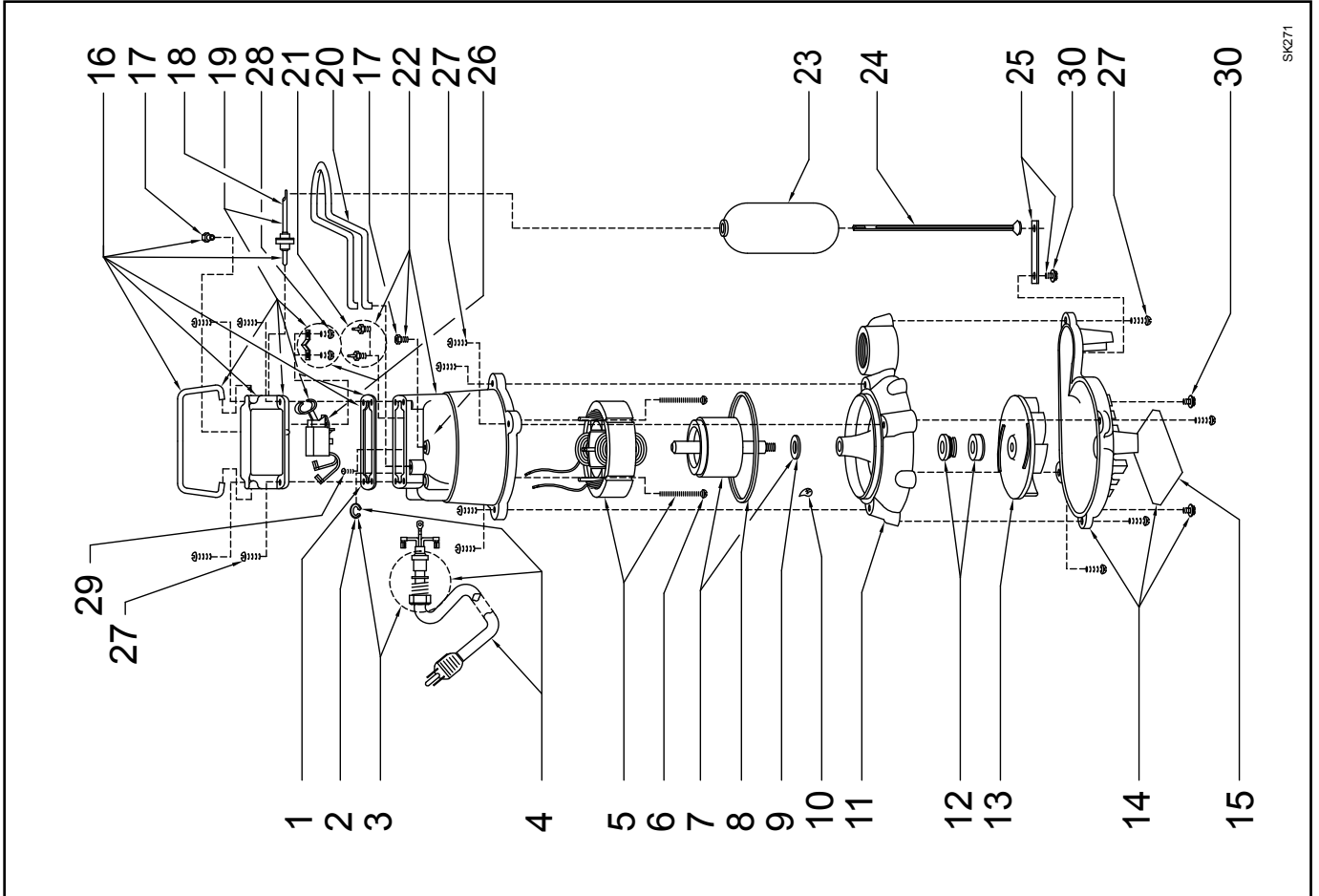

SK271

REPLACEMENT PARTS ILLUSTRATION FOR MODELS "N53" AND "E53"

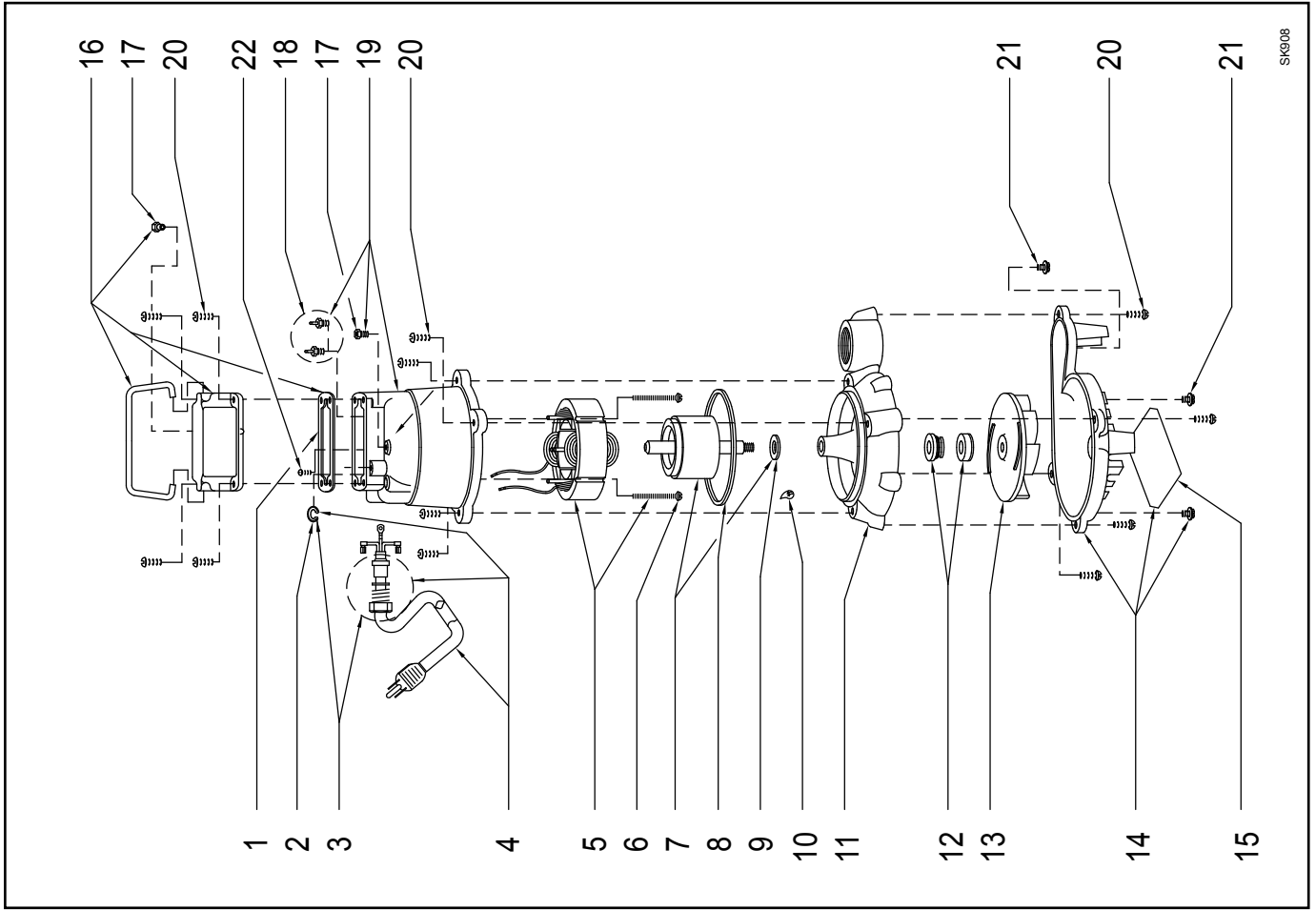

SK908