

ProPEX® Engineered Polymer (EP) Tee

Submittal information

Revision H: May 23, 2019

Project information

Job name:

Location:

Part no. ordered:

Engineer:

Date submitted:

Contractor:

Submitted by:

Manufacturer's representative:

Approved by:

Technical data

Material:	Engineered polymer (EP)
Maximum temperature (no pressure):	320°F (160°C)
Maximum working temperature/pressure:	210°F (99°C) at 150 psi (1,034 kPa)

Product information and application use

ProPEX® engineered polymer (EP) tees make diverting connections for Uponor crosslinked polyethylene (PEX-a) tubing for use in hot and cold domestic potable water systems, residential fire sprinkler systems and hydronic radiant heating and cooling systems. Each end of the tee is manufactured with an Uponor ProPEX fitting for connections to Uponor AquaPEX® or Wirsbo hePEX™ tubing.¹

Note: Branch size is listed last in the part descriptions.

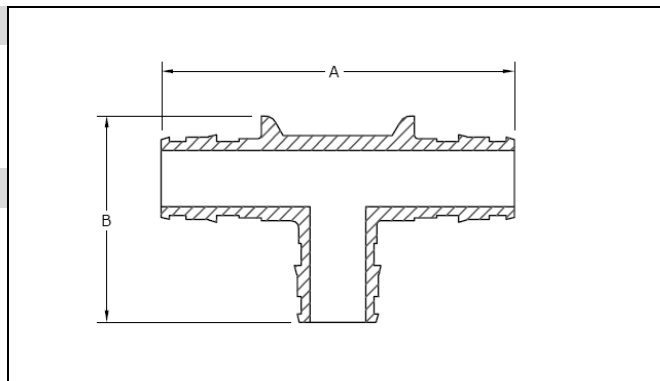

✓ Description	Part number	A	B	Weight	Equivalent length (ft.) through	Equivalent length (ft.) branch	Cv through	Cv branch
ProPEX EP Tee, ½" PEX x ½" PEX x ½" PEX	Q4755050	2.50"	1.53"	0.02 lbs.	1.0	6.3	7.7	3.4
ProPEX EP Tee, ¾" PEX x ¾" PEX x ¾" PEX*	Q4757575	3.30"	1.94"	0.05 lbs.	1.5	15.6	15.7	5.4
ProPEX EP Tee, 1" PEX x 1" PEX x 1" PEX*	Q4751010	4.10"	2.47"	0.07 lbs.	1.3	12.7	30.5	11.3
ProPEX EP Tee, 1¼" PEX x 1¼" PEX x 1¼" PEX*	Q4751313	4.80"	3.22"	0.15 lbs.	3.8	8.6	34.0	23.9
ProPEX EP Tee, 1½" PEX x 1½" PEX x 1½" PEX	Q4751515	5.80"	3.82"	0.25 lbs.	1.8	10.6	63.7	31.0
ProPEX EP Tee, 2" PEX x 2" PEX x 2" PEX	Q4752000	7.45"	4.79"	0.38 lbs.	0.8	15.5	150.7	52.5
ProPEX EP Tee, 2½" PEX x 2½" PEX x 2½" PEX	Q4752500	10.56"	5.45"	1.14 lbs.	2.7	22.3	197.2	81.5
ProPEX EP Tee, 3" PEX x 3" PEX x 3" PEX	Q4753000	12.26"	6.37"	1.86 lbs.	2.8	23.9	286.6	122.8

Installation

Use the appropriate ProPEX Ring for PEX-a tubing. Refer to the Uponor Professional Plumbing Installation Guide, AquaSAFE™ Residential Fire Sprinkler Installation Guide or Uponor Radiant Installation Handbook for additional information.

Standards

ASTM E84; ASTM E119; ASTM E814; ASTM F877; ASTM F1960; CAN/CSA B137.5; NSF 14; NSF 61

Codes

IBC; IMC; IPC; IRC; NPC of Canada; NSPC; UMC; UPC

Listings

cNSFus-pw; *cNSFus-pw-fs; cQAlus P321; HUD MR 1269; ICC-ES-PMG-1006; ICC-ES-PMG-1012; *UL 1821; *ULC/ORD-C199P; U.P. Code

Related applications

PEX-a plumbing systems
 Hydronic radiant heating and cooling systems
 Snow and ice melting systems
 Turf conditioning systems
 Permafrost prevention systems
 AquaSAFE™ fire safety systems

Contact information

Uponor, Inc.
 5925 148th Street West
 Apple Valley, MN 55124 USA
 Phone: 800.321.4739
 Fax: 952.891.2008
 uponorpro.com

Uponor Ltd.
 6510 Kennedy Road
 Mississauga, ON L5T 2X4 CANADA
 Phone: 888.994.7726
 Fax: 800.638.9517
 uponorpro.com

¹ProPEX® is a registered trademark of Uponor, Inc. ProPEX™ is a trademark of Uponor Ltd.