



RELIABILITY BUILT IN™

**Limited One Year Warranty
(Commercial Applications)**

T&S warrants to the original purchaser (other than for purposes of resale) that such product is free from defects in material and workmanship for a period of one (1) year from the date of purchase. During this one-year warranty period, if the product is found to be defective, T&S shall, at its options, repair and/or replace it. To obtain warranty service, products must be returned to...

*T&S Brass and Bronze Works, Inc.
Attn: Warranty Repair Department
2 Saddleback Cove
Travelers Rest, SC 29690*

Shipping, freight, insurance, and other transportation charges of the product to T&S and the return of repaired or replaced product to the purchaser are the responsibility of the purchaser. Repair and/or replacement shall be made within a reasonable time after receipt by T&S of the returned product. This warranty does not cover Items which have received secondary finishing or have been altered or modified after purchase, or for defects caused by physical abuse to or misuse of the product, or shipment of the products.

Any express warranty not provided herein, and any remedy for Breach of Contract which might arise, is hereby excluded and disclaimed. Any implied warranties of merchantability or fitness for a particular purpose are limited to one year in duration. Under no circumstances shall T&S be liable for loss of use or any special consequential costs, expenses or damages.

Some states do not allow limitations on how long and implied warranty lasts or the exclusion or limitation of incidental or consequential damages, so the above limitations or exclusions may not apply to you. Specific rights under this warranty and other rights vary from state to state.

Attention California Residents:

"WARNING: This product contains chemicals known to the State of California to cause cancer, and birth defects or other reproductive harm."

P/N: 098-009518-45 Rev.3
Date: 08-15-16
Drawn: TEH
Checked: JRM 09-29-16
Approved: JHB 10-08-16

Installation and Maintenance Instructions



Surgical Sink and Service Sink Faucets with Built-In Stops B-0665-BST Series

ES

Español:

Instrucciones de instalación y mantenimiento

FR

Français:

Instructions pour l'installation et la maintenance

DE

Deutsch:

Installations- und Wartungsanleitungen

CN

中文:

安装与维护说明

Exploded View

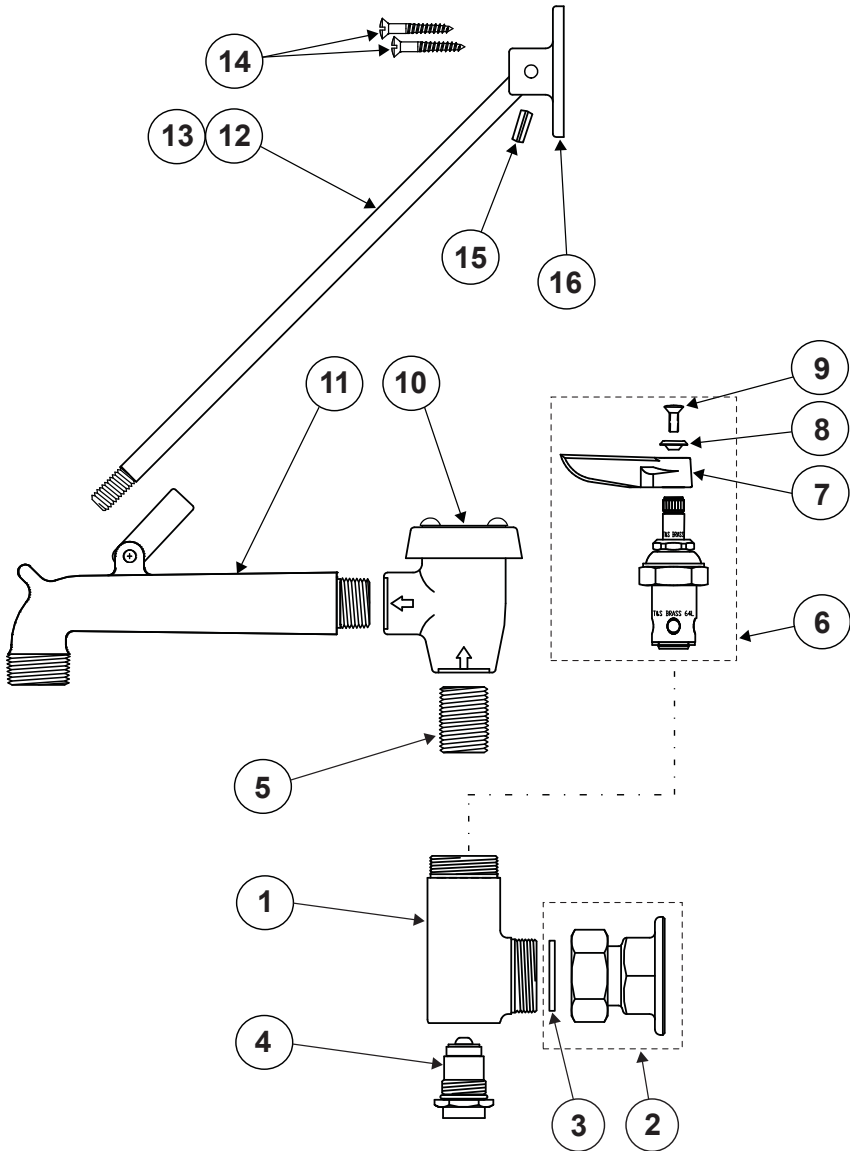

Part Number Guide

Service Sink Faucet Assemblies

1	Body, Faucet	N/A
2	Asm, Flange Coupling	00AA
3	Washer, Coupling Flange	001019-45
4	Asm, BST Spindle & Insert	163A
5	Nipple, Close 1/2 HWL	002534-25
6	Asm, Eterna w/ Spring Checks & Handle (Cold)	002711-40
	Asm, Eterna w/ Spring Checks & Handle (Hot)	002712-40
7	Handle, Lever (Blank)	001638-45
8	Index, Button (Red / Hot)	001661-45
	Index, Button (Blue / Cold)	001660-45
9	Screw, Handle	000922-45
10	Asm, Vacuum Breaker, 1/2"	B-0969
11	Spout (BSTR)	009545-25
	Spout (BSTP)	009545-40
12	Asm, Upper Nozzle Support	009546-40
13	Rod, Support	005060-40
14	Screw, Wall Mount (1 each)	000915-45
15	Pin, Coiled 3/16" x 1/2" S.S.	004713-25
16	Flange	003007-40

EN *Note: This is a general instructional example of units using -BST. Nozzles should be installed on unit first.*

ES *Nota: Esto es un ejemplo general instruccional de unidades que utilizan -BST. (Interceptor Incorporado.) Primero se debe de instalar las boquillas.*

FR *Celui-ci être un exemple générale et instructif des élément s qui utiliser BST Les ajutages devoir être installer au début.*

DE *Anmerkung: Die ist ein allgemeines Installationsbeispiel für Armaturen, die BST verwenden. Düsen sollten zuerst auf die Einheit installiert werden.*

CN *注意：这是-BST系列的常规说明样例。首先应将水嘴安装在装置上。*

EN Faucet Installation:

1. Shut off water supply and drain lines. Drill (2) two 7/8" [2.2 cm] holes in wall or backsplash of sink, 8" [20 cm] center to center, where you are installing no.1.
2. Apply teflon tape or pipe joint compound to threads of water supply lines.
3. Remove no.2 from no.1 and attach no.2 to water supply lines flush against wall. Tighten by hand. *Trim supply lines if necessary.*
4. Attach no.1 to no.2, adjusting center to center fit by turning no.2 if needed. *Make sure no.3 remains in place.* Tighten no.2 firmly with a wrench.
5. Turn on water supply and check for leaks.

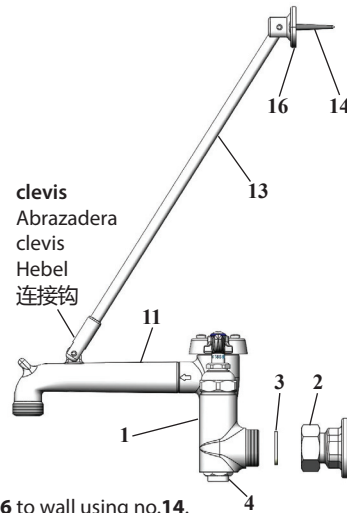

Upper Nozzle Support Installation:

6. Attach no.13 to no.11 by screwing no.13 into *clevis* on no.11.
7. Position no.16 against wall. Mark holes and secure no.16 to wall using no.14.

ES Instalación De La Canilla:

1. Cierre la fuente de agua y desagüe las tuberías. Perfore (2) dos huecos de 2 cm en la pared o el espaldar del lavatorio, con 20 cm de centro a centro donde la parte No.1 será instalada.
2. Aplique cinta de Teflon o compuesto de coyuntura a las roscas de las líneas de surtido.
3. Remuéva la parte No.2 de la parte No.1 y conecte la parte No.2 a las líneas de surtido pareja con la pared. Apreté a mano. *Si es necesario recorte las líneas de surtido.*
4. Conecte la parte No.1 a la parte No.2, ajustando la medida de centro a centro girando la parte No.2 si es necesario. *Asegúrese que la parte No.3 permanezca situada.* Con una llave aprete firmemente la parte No.2.
5. Abra el surtido de agua e inspeccione por filtraciones.

Instalación De Soporte Superior:

6. Conecte la parte No.13 a la parte No.11 atornillando la parte No.13 dentro de la abrazadera en la parte No.11.
7. Coloque la parte No.16 contra la pared. Señale los huecos y asegure la parte No.16 a la pared usando la parte No.14.

FR L'Installation du Robinet:

1. Fermer la réserve de l'eau et égoutter la tuyauterie. Percer (2) deux trous de 2.2cm dans le mur ou le garde-boue de l'évier 20cm de centre à centre où vous aller installer N°1.

2. Appliquer le ruban en Téflon ou le composé pour les tuyaux aux tuyaux qui fournir l'eau.
3. Enlever N°. 2 de N°.1 et attacher N°.2 aux tuyaux qui fournir l'eau au même niveau du mur. Resserer par le main. **Couper les tuyaux qui fournir l'eau si nécessaire.**
4. Attacher N°.1 à N°.2, en réglant l'ajustement centre à centre en tournant N°.2 si nécessaire. **Soyez certain que N°.3 rester à sa place.** Resserer N°.2 fermement avec une clef anglaise.
5. Recommencer l'eau et vérifier s'il y a des fuites.

L'Installation du Support de L'Ajutage en Haut:

6. Attacher N°.13 à N°.11 en vissant N°.13 dans le clevis sur N°.11.
7. Mettre N°.16 contre le mur. Marquer les trous et attacher N°.16 au mur en utilisant N°.14.



Einbau des Wasserhahns:

1. Den Wasserzulauf schließen und die Leitungen leeren. Zwei 2 cm Löcher in die Wand oder die Rückwand der Spüle - je nachdem, wo Nr. 1 installiert werden soll - mit einem Mittenabstand von 20 cm bohren.
2. Für die Gewinde der Wasserleitungen Teflonband oder Rohrdichtungsmasse verwenden.
3. Nr. 2 von Nr. 1 entfernen und Nr. 2 bündig zur Wand auf die Wasserzulaufleitungen aufdrehen. Mit der Hand festziehen. **Zulaufleitungen bei Bedarf kürzen.**
4. Nr. 1 an Nr. 2 befestigen, wobei auf mittigen Sitz zu achten ist und bei Bedarf Nr. 2 gedreht werden kann. **Sicherstellen, daß Nr.3 an Ort und Stelle verbleibt!** Nr. 2 mit einem Schrauben schlüssel festdrehen.
5. Wasserzulauf andrehen und auf Dichtigkeit überprüfen.

Einbau des oberen Schwenkarms:

6. Nr. 13 an Nr. 11 befestigen, indem Nr. 13 an dem Hebel auf Nr. 11 angeschraubt wird.
7. Nr. 16 an der Wand in Position bringen. Löcher markieren und Nr. 16 mit Hilfe von Nr. 14 an der Wand sichern.



龙头的安装:

1. 关闭供水和排水管道。在墙面或者水槽的防溅挡板上面钻（2）两个7/8" [2.2cm]的孔，中心距为8" [20cm]，在孔上安装1号。
2. 在供水管道的螺纹上缠上胶带或涂上管道胶合剂。
3. 将2号从1号上拆下，把2号平对着墙装在供水管道上，用手拧紧。根据实际情况修整供水管道。
4. 把1号装到2号上，可根据需求旋转2号来调整中心距。请务必确保3号在准确的位置。用扳手将2号牢牢拧紧。
5. 打开供水开关，检查是否漏水。

水嘴上方支架安装:

6. 把13号拧到11号上的连接钩上。
7. 将16号靠墙放好，并做好记号，用14号把16号固定在墙上。



Adjusting Built-in Stops:

Insert a screwdriver to adjust no.4 at the base of no.1 on each side. **Water should be turned on for this procedure.**

Close Stop turn clockwise

Detenedor **cerrado** gire a la derecha
Fermer l'arrêt tourner dans le sens des
aiguilles d'une montre



Anschlag für Geschlossen:

im Uhrzeigersinn drehen
顺时针方向关闭开关



Open Stop turn counterclockwise

Detenedor **Abierto** gire a la izquierda
Ouvert l'arrêt tourner dans le sens
inverse des aiguilles d'une montre

Anschlag für Offen:

gegen den Uhrzeigersinn drehen
逆时针方向打开开关

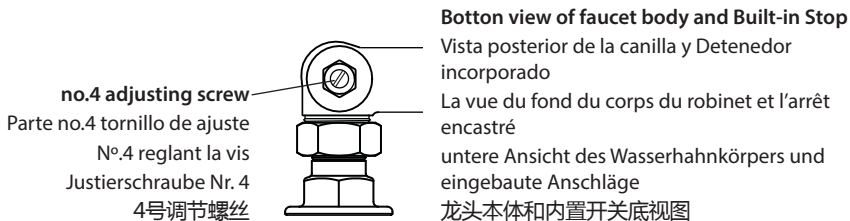

ES Ajuste De Los Detenedores Incorporados:

Para ajustar la parte No.4 insarte un destornillador por debajo de la parte No.1 en ambos lados. *El agua debe estar abierta para este proceso.*

FR La Réglage des Arrêts Encastrés:

Insérer un tournevis pour régler N°.4 à la base de N°.1 sur chaque côté. *On devoir déjà recommencer l'eau pour ce processus.*

DE Eingebaute Anschläge justieren:

Mit einem Schraubenzieher die Nr. 4 an dem Fuß von der Nr. 1 auf beiden Seiten justieren. *Das Wasser sollte hierfür aufgedreht werden.*

CN 调整内置开关：

可用螺丝刀调整1号的两侧底部的4号来控制水流大小。在这一步骤中，需要打开供水。

RELATED T&S BRASS PRODUCT LINE



B-0657
Service Sink /
Mop Sink Faucet

B-0674-RGH
Service Sink /
Mop Sink Faucet



T&S BRASS AND BRONZE WORKS, INC.

A firm commitment to application-engineered plumbing products

2 Saddleback Cove, P.O. Box 1088,
Travelers Rest, SC 29690

Phone: (864) 834-4102

Fax: (864) 834-3518

E-mail: tsbrass@tsbrass.com

T & S Brass-Europe
'De Veenhoeve'
Oude Nieuwveenseweg 84
2441 CW Nieuwveen

The Netherlands



RELIABILITY BUILT IN™