

508 1/4"-3"

Bronze Check Valve
200 SWP - 400 WOG †
Horizontal Swing • Threaded Ends
Y-Pattern
Conforms to: MSS SP-80

MATERIAL LIST			
No.	PART	MATERIAL	SPECIFICATION
1	Body	Cast Bronze	ASTM B61
2	Cap	Cast Bronze	ASTM B61
3	Disc	Cast Bronze	ASTM B61
4	Lever	Cast Bronze	ASTM B61
5	Pin	St. Steel	Commercial
6	Plug (not shown)	Rod Brass	ASTM B16
7	Retaining Ring	St. Steel	ASTM A276 TY.304

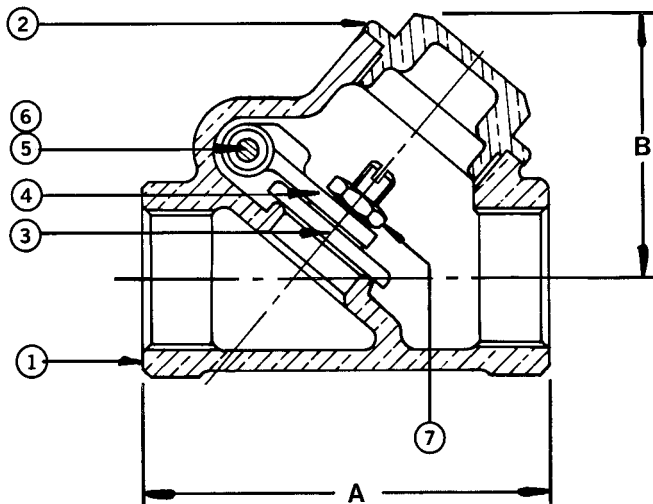

Note: Not intended for use in potable water.

DIMENSIONS - INCHES/MILLIMETERS				
Units	Size	A	B	C _v
Inches mm	1/4	2.25 57	1.63 41	2.3
Inches mm	3/8	2.25 57	1.63 41	4.3
Inches mm	1/2	2.63 67	1.75 44	7.2
Inches mm	3/4	3.00 76	1.94 49	13.0
Inches mm	1	3.69 94	2.50 64	22.0
Inches mm	1 1/4	4.38 111	3.00 76	39.0
Inches mm	1 1/2	4.63 118	3.31 84	56.0
Inches mm	2	5.88 149	4.00 102	92.0
Inches mm	2 1/2	7.00 178	4.75 121	150.0
Inches mm	3	7.88 200	5.00 127	240.0

† Non-Shock

INNOVATION IN EVERY VALVE

The information presented on this sheet is correct at time of publication. Milwaukee Valve reserves the right to change design and/or materials without notice. For our Installation, Operation and Maintenance Manual and the most current product information go to www.milwaukeevalve.com. ⚠ State of California Prop 65
WARNING: Cancer and Reproductive Harm. For more information visit www.p65warnings.ca.gov.

