



**Badger Meter**

## Recordall® Turbo Series Meters

Models 160 (1-1/2 in.), 200 (2 in.), 450 (3 in.), 1000 (4 in.),  
2000 (6 in.), 3500 (8 in.), 5500 (10 in.), 6200 (12 in.)

**Models without Integral Strainers, Sizes 1-1/2...12 in.**



**Models with Integral Strainers, Sizes 1-1/2...4 in.**

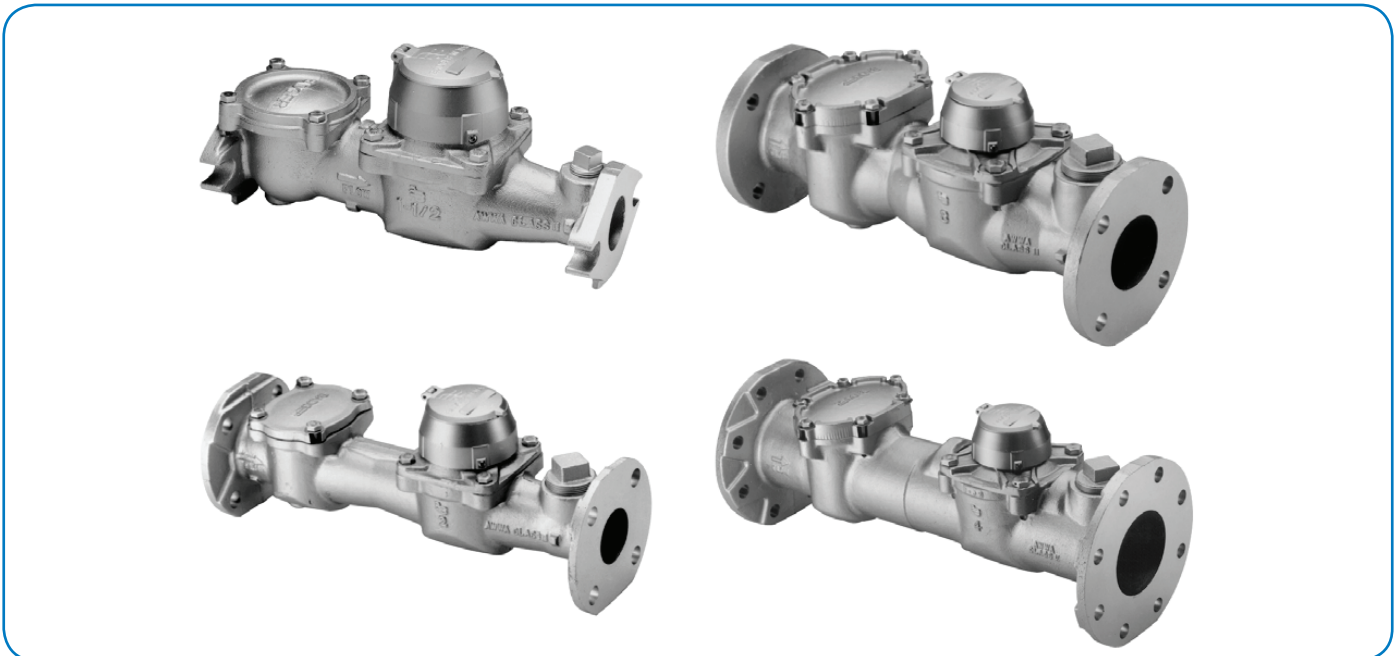

Sizes 1-1/2 in., 2 in., 3 in. and 4 in.

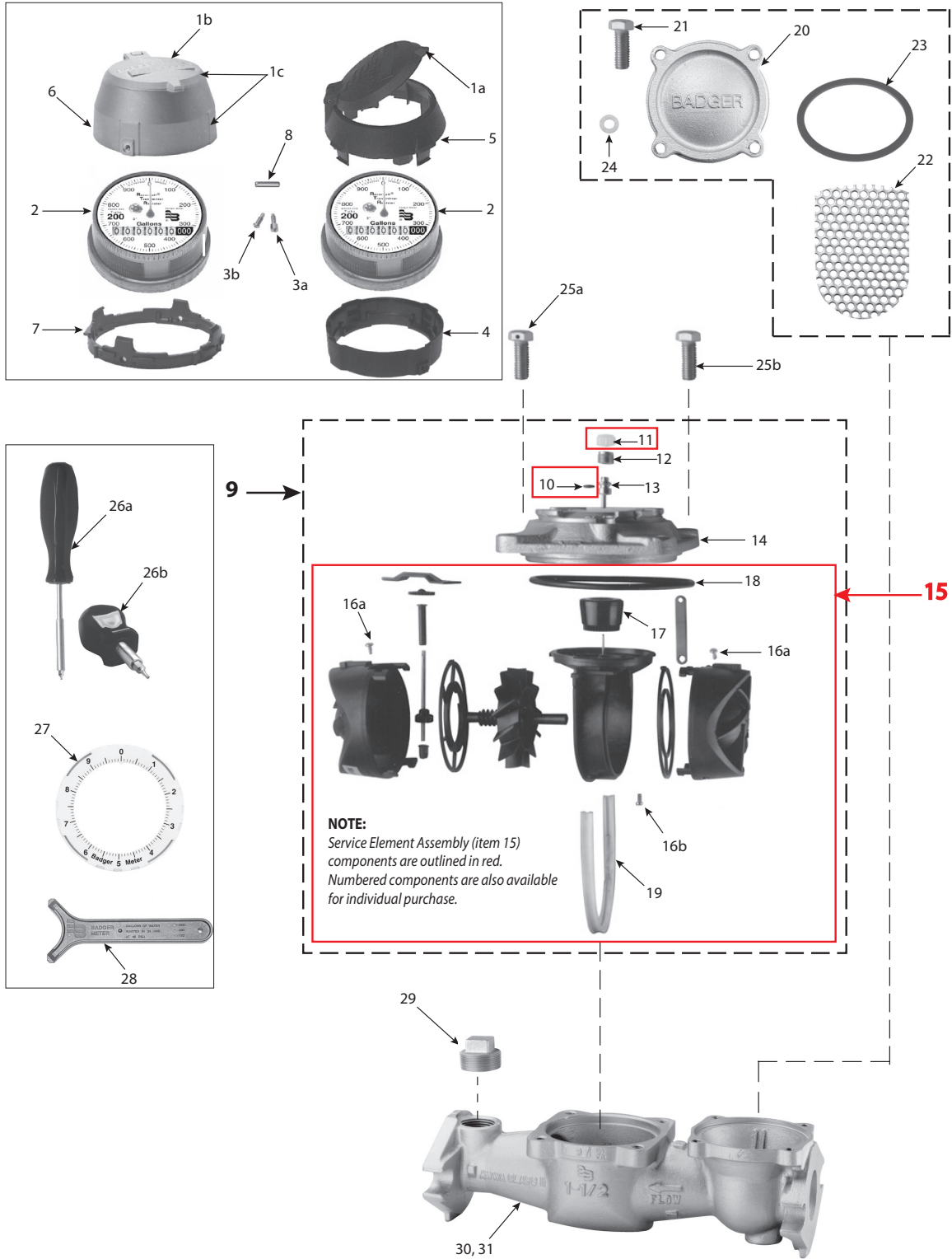

Item	Description	Part Numbers for Sizes 1-1/2 in., 2 in., 3 in. and 4 in.			
		1-1/2 in.	2 in.	3 in.	4 in.
1a	Register flat lid (plastic) medium gray	62278-003	62278-003	62278-003	62278-003
1b	Register flat lid (bronze)	62353-001	62353-001	62353-001	62353-001
1c	Register flat lid and shroud (bronze)	62616-001	62616-001	62616-001	62616-001
2	Register, 100 gallon T. C.	64085-001	64085-002	64085-003	64085-004
	Register, 100 gallon T. C. (Reclaimed)	64085-031	64085-032	64085-033	64085-034
	Register, 10 cubic ft T.C.	64085-005	64085-006	64085-007	64085-008
	Register, 10 cubic ft T.C. (Reclaimed)	64085-035	64085-036	64085-037	64085-038
	Register, 1 cubic meter T. C.	64085-009	64085-010	64085-011	64085-012
	Register, 1000 gallon T.C.	—	—	—	—
	Register, 100 cubic ft T.C.	—	—	—	—
3a	Tamper-resistant screw, standard (for local register, ADE®, RTR®)	62335-001	62335-001	62335-001	62335-001
	Tamper-resistant screw, standard (for HR-E® LCD encoder, not shown)	62624-001	62624-001	62624-001	62624-001
3b	Tamper-resistant TORX® seal screw (for local register, ADE, RTR)	62516-001	62516-001	62516-001	62516-001
	Tamper-resistant TORX seal screw (for HR-E LCD encoder, not shown)	62516-002	62516-002	62516-002	62516-002
3c	Tamper-resistant keyed seal screw, standard (for local register, ADE, RTR)	66925-001	66925-001	66925-001	66925-001
	Tamper-resistant keyed seal screw, short (for HR-E LCD encoder, not shown)	66925-003	66925-003	66925-003	66925-003
4	Plastic shroud (bottom half) medium gray	62279-009	62279-009	62279-009	62279-009
5	Plastic shroud (top half) medium gray	62280-004	62280-004	62280-004	62280-004
6	Bronze shroud (for flat lid)	62442-001	62442-001	62442-001	62442-001
7	Plastic insert for flat lid bronze shroud	62455-001	62455-001	62455-001	62455-001
8	Flat lid hinge pin	59568-003	59568-003	59568-003	59568-003
9	Head assembly (LL), complete	63010-024	63010-025	63010-026	63010-027
	Head assembly (LL), complete (for models with integral strainer)	63010-025	63010-025	63010-026	63010-027
10	O-Ring, calibration shaft	62754-001	62754-001	62754-001	62754-001
11	Seal plug, calibration shaft	62793-001	62793-001	62793-001	62793-001
12	Lock screw, calibration shaft	68291-001	68291-001	68291-001	68291-001
13	Calibration shaft	68288-001	68288-001	68288-001	68288-001
14	Cover plate (LL)	66131-002	66131-002	66132-002	66132-002
15	Service element assembly	62755-038	62755-042	62755-039	62755-043
	Service element assembly (for models with integral strainer)	62755-042	62755-042	62755-039	62755-043
16a	Cage / nose cone setscrews (2 required)	62976-007	62976-007	62976-007	62976-007
16b	Cage setscrew (1 required)	62976-005	62976-005	62976-005	62976-005
17	Magnet carrier with top ball	62976-018	62976-018	62976-019	62976-019
18	O-Ring, head	62754-002	62754-002	62754-003	62754-003
19	Cage seal	62924-001	62924-001	62924-002	62924-002
20	Strainer cover (LL) (for models with integral strainer)	62635-005	63233-003	63281-003	63281-003
21	Cover Bolt (for models with integral strainer)	55031-033	55031-060	55031-062	55031-062
22	Screen (for models with integral strainer)	63115-001	63277-001	63283-001	63285-001
23	Gasket (for models with integral strainer)	11071-033	22650-050	22650-051	22650-051
24	Washer for strainer cover (for models with integral strainer)	—	55262-015	55262-015	55262-015
25a	Head bolt, w/seal hole (1 required)	25421-043	25421-043	25421-034	25421-034
25b	Head bolt, w/o seal hole (3 required)	55031-060	55031-060	55031-116	55031-116
26a	TORX seal screw driver and bit (long)	62658-003	62658-003	62658-003	62658-003
26b	TORX seal screw driver and bit (stubby)	62658-001	62658-001	62658-001	62658-001
27	Register test ring	62446-001	62446-001	62446-001	62446-001
28	Plastic shroud disassembly tool	62346-001	62346-001	62346-001	62346-001
29	Test plug (LL)	33879-016	33879-014	33879-012	33879-012
30	Housing, round flange (LL), w/o test plug	—	62748-007	62764-006	62765-006
	Housing, round flange (LL), w/ test plug	—	62748-006	62764-007	62765-005
	Housing, round flange (LL), w/o test plug (for models with integral strainer)	—	63220-003	63127-005	63128-007
31	Housing, elliptical flange (LL) w/o test plug	62747-006	62749-006	—	—
	Housing, elliptical flange (LL) w/ test plug	62747-005	62749-005	—	—
	Housing, elliptical flange (LL) w/ test plug (for models with integral strainer)	63125-005	63126-005	—	—
—	TORX seal screw driver bit (not shown)	62657-001	62657-001	62657-001	62657-001
—	Driver bit, keyed seal screw (not shown)	66925-002	66925-002	66925-002	66925-002
—	Bit driver, stubby, without bit (not shown)	62658-005	62658-005	62658-005	62658-005
—	Bit driver, standard, without bit (not shown)	62658-006	62658-006	62658-006	62658-006

Sizes 6 in., 8 in., 10 in. and 12 in.

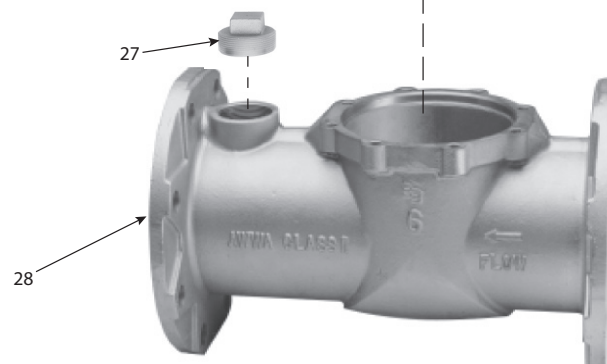
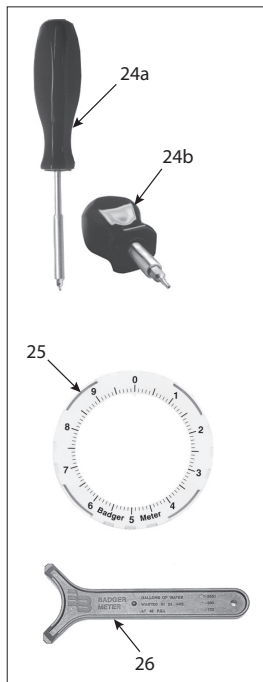
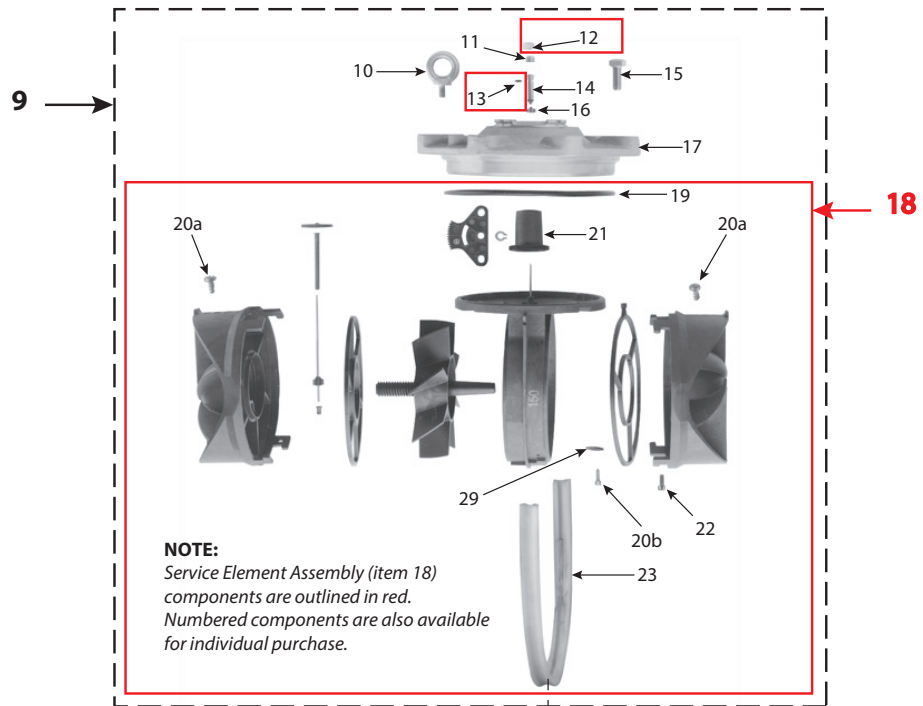
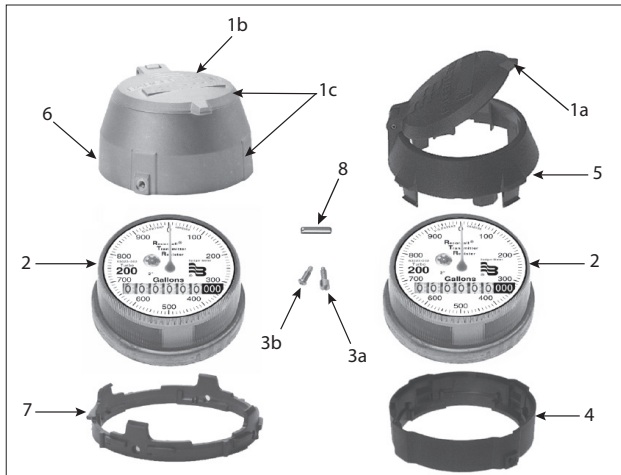

**NOTE:**  
Service Element Assembly (item 18)  
components are outlined in red.  
Numbered components are also available  
for individual purchase.

Item	Description	Part Numbers Part Numbers for Sizes 6 in., 8 in., 10 in. and 12 in.			
		6 in.	8 in.	10 in.	12 in.
1a	Register flat lid (plastic) medium gray	62278-003	62278-003	62278-003	62278-003
1b	Register flat lid (bronze)	62353-001	62353-001	62353-001	62353-001
1c	Register flat lid and shroud (bronze)	62616-001	62616-001	62616-001	62616-001
2	Register, 10,000 gallon T. C.	—	—	—	64085-043
	Register, 10,000 gallon T. C. (reclaimed)	—	—	—	64085-047
	Register, 1000 cubic ft T.C.	—	—	—	64085-044
	Register, 1000 cubic ft T.C. (reclaimed)	—	—	—	64085-048
	Register, 1 cubic meter T. C.	—	—	—	—
	Register, 1000 gallon T.C.	64085-017	64085-018	64085-019	—
	Register, 1000 gallon T.C. (reclaimed)	64085-039	64085-041	64085-049	—
	Register, 100 cubic ft T.C.	64085-020	64085-021	64085-022	—
	Register, 100 cubic ft T.C. (reclaimed)	64085-040	64085-042	64085-050	—
Register, 10 cubic meter T.C.	64085-023	64085-024	64085-025	64085-045	
3a	Tamper-resistant screw, standard (for local register, ADE, RTR)	62335-001	62335-001	62335-001	62335-001
	Tamper-resistant screw, standard (for HR-E LCD encoder, not shown)	62624-001	62624-001	62624-001	62624-001
3b	Tamper-resistant TORX seal screw (for local register, ADE, RTR)	62516-001	62516-001	62516-001	62516-001
	Tamper-resistant TORX seal screw (for HR-E LCD encoder, not shown)	62516-002	62516-002	62516-002	62516-002
3c	Tamper-resistant keyed seal screw, standard (for local register, ADE, RTR)	66925-001	66925-001	66925-001	66925-001
	Tamper-resistant keyed seal screw, short (for HR-E LCD encoder, not shown)	66925-003	66925-003	66925-003	66925-003
4	Plastic shroud (bottom half) medium gray	62279-009	62279-009	62279-009	62279-009
5	Plastic shroud (top half) medium gray	62280-004	62280-004	62280-004	62280-004
6	Bronze shroud (for flat lid)	62442-001	62442-001	62442-001	62442-001
7	Plastic insert for flat lid bronze shroud	62455-001	62455-001	62455-001	62455-001
8	Flat lid hinge pin	59568-003	59568-003	59568-003	59568-003
9	Head assembly (LL), complete	63010-028	63010-029	63010-030	63010-048
10	Eyebolts	59215-039	59215-067	59215-067	59215-067
11	Lock screw, calibration shaft	68291-001	68291-001	68291-001	68291-001
12	Seal plug, calibration shaft	62793-001	62793-001	62793-001	62793-001
13	O-Ring, calibration shaft	62754-001	62754-001	62754-001	62754-001
14	Calibration shaft	68289-001	68290-001	68290-001	68290-001
15	Head bolt, w/seal hole (6 in., 1 required; 8... 12 in., 2 required)	25421-044	58088-004	58088-004	58088-004
	Head bolt, w/o seal hole (6 in., 7 required; 8... 12 in., 8 required)	55031-117	55031-172	55031-172	55031-172
16	Calibration gear	62976-031	62976-031	62976-031	62976-031
17	Cover plate (LL)	66133-002	66134-002	66134-002	66134-002
18	Service Element Assembly	62755-040	62755-041	62755-044	62755-044
19	O-Ring, head	62754-004	62754-005	62754-005	62754-005
20a	Cage / nose cone setscrews (2 required)	62976-050	62976-050	62976-050	62976-050
20b	Cage setscrew (4 required)	63177-011	62976-044	62976-044	62976-044
21	Magnet carrier (with top ball)	63177-015	62976-047	62976-047	62976-047
22	Screw	—	62976-007	62976-007	62976-007
23	Cage seal	62924-003	62924-004	—	—
24a	TORX seal screw driver and bit (long)	62658-003	62658-003	62658-003	62658-003
24b	TORX seal screw driver and bit (stubby)	62658-001	62658-001	62658-001	62658-001
25	Register test ring	62446-001	62446-001	62446-001	62446-001
26	Plastic shroud disassembly tool	62346-001	62346-001	62346-001	62346-001
27	Test plug (LL)	33879-012	33879-012	—	—
28	Housing, round flange (LL) w/o test plug	62837-006	—	63355-003	—
	Housing, round flange (LL) w/ test plug	62837-005	63304-004	—	—
	Housing, round flange (Cast Iron) w/o test plug	—	—	—	67101-017
29	Washer (4 required)	63177-012	62976-049	62976-049	62976-049
—	TORX seal screw driver bit (not shown)	62657-001	62657-001	62657-001	62657-001
—	Driver bit, keyed seal screw (not shown)	66925-002	66925-002	66925-002	66925-002
—	Bit driver, stubby, without bit (not shown)	62658-005	62658-005	62658-005	62658-005
—	Bit driver, standard, without bit (not shown)	62658-006	62658-006	62658-006	62658-006

**THIS PAGE INTENTIONALLY BLANK**

**THIS PAGE INTENTIONALLY BLANK**

**SMART WATER IS BADGER METER**

ADE, GALAXY, HR-E, ORION, Recordall and RTR are registered trademarks of Badger Meter, Inc. Other trademarks appearing in this document are the property of their respective entities. Due to continuous research, product improvements and enhancements, Badger Meter reserves the right to change product or system specifications without notice, except to the extent an outstanding contractual obligation exists. © 2020 Badger Meter, Inc. All rights reserved.