

L
 DRAWING NUMBER S4031
 SIZE A
 SCALE: NONE
 DATE: 2-16-70
 APPROVED BY: JM
 CHECKED BY: BH
 DRAWN BY: RK
4031 SERIES
 FIGURE NUMBER

WE CAN ASSUME NO RESPONSIBILITY FOR USE OF SUPERSEDED OR VOID DATA

FINISHED FLOOR CLEANOUTS WITH "TWIS-TO-FLOOR®" ADJUSTABLE TOPS

ROUND NICKEL BRONZE TOP

FUNCTION: For use in finished floors bearing foot and medium load wheeled traffic. Allows for easy floor level adjustment.
 "C.O." cast in Secured Cover

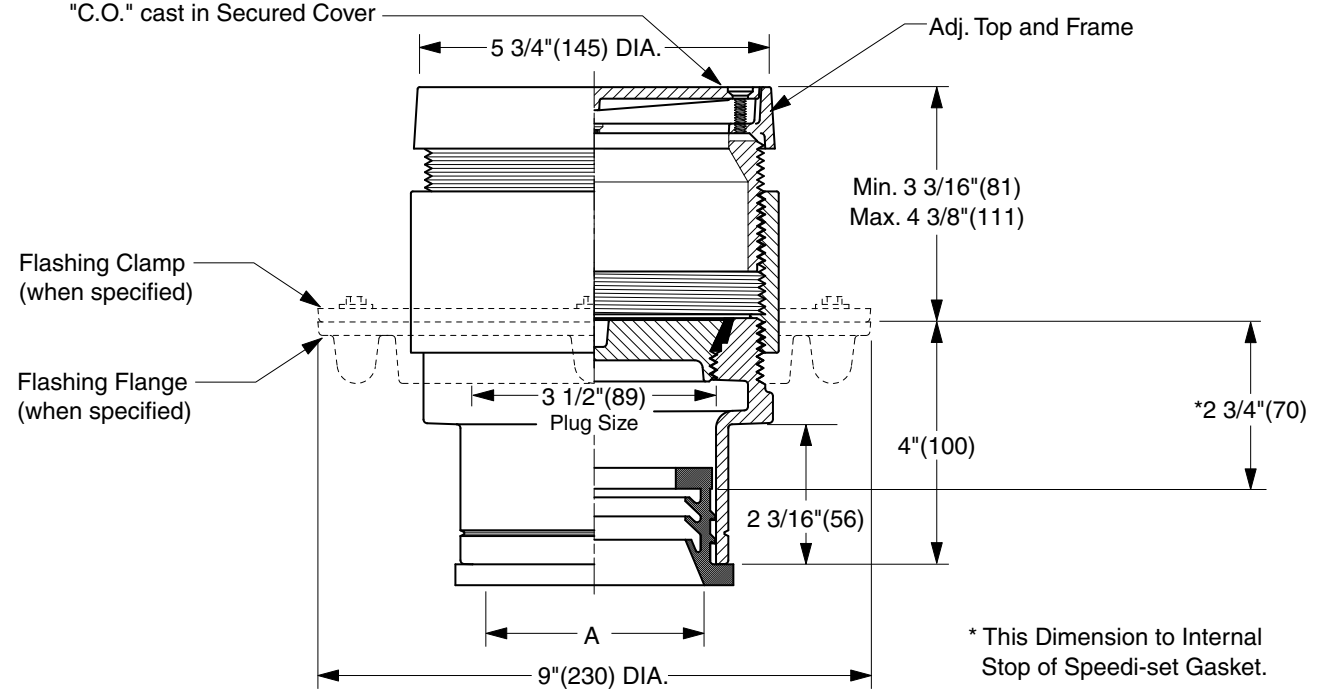

* This Dimension to Internal Stop of Speedi-set Gasket.

NOTE: For applications using core drilling, the largest diameter of the cleanout assembly is 6 5/16" (160).

TWIS-TO-FLOOR® ADJUSTMENT
 SPEEDI-SET OUTLET ▲

"A" (Pipe Size) = 02(50), 03(75) or 04(100)

- Fig. 4031L.....Gasket Seal - ABS Plug
- Fig. 4032L.....Gasket Seal - Bronze Plug
- Fig. 4033L.....Taper Thread - Bronze Plug
- Fig. 4034L.....Taper Thread - ABS Plug

(Twis-to-Floor® design shown with gasketed plug.)

NOTE: Dimensions shown in parentheses are in millimeters.

REGULARLY FURNISHED:

Duco Cast Iron Cleanout with Round Adjustable Scoriated Secured Nickel Bronze Top. Closure Plug Type as Indicated By Figure Number Selected.

VARIATIONS:

- Flashing Flange -F
- Flange with Flashing Clamp -F-C
- Carpet Clamping Type -X
- Carpet Marker Type -Y
- Vandal Proof Top -U
- Wide Flange (DX)

OPTIONAL MATERIALS:

- Galvanized Cast Iron -G
- Polished Bronze Top -PB

▲ Available in Extra Heavy, Service Weight or NO-HUB.

L	12/17/04	Added Core-Drilling Note	JJ	CL			
K	07/26/02	Corrected Clamp & Flange view	JJ	CL	WEIGHT	VOLUME	FIGURE NUMBER
J	04/12/01	Added dimension and note	JJ	CL	POUNDS	CUBIC FEET	4031 SERIES
H	10/17/00	New design	JJ	BS			
REV.	DATE	DESCRIPTION	BY	CKD. BY			



JAY R. SMITH MFG. CO.
 DIVISION OF SMITH INDUSTRIES, INC.
 POST OFFICE BOX 3237
 MONTGOMERY, ALABAMA 36109-0237 (USA)
 TEL: 334-277-8520 FAX: 334-272-7396 www.jrsmith.com



LOCATION

FINISHED FLOOR CLEANOUTS WITH "TWIS-TO-FLOOR" ADJUSTABLE TOPS

ROUND NICKEL BRONZE TOP

FUNCTION: For use in finished floors bearing foot and medium load wheeled traffic. Allows for easy floor level adjustment.

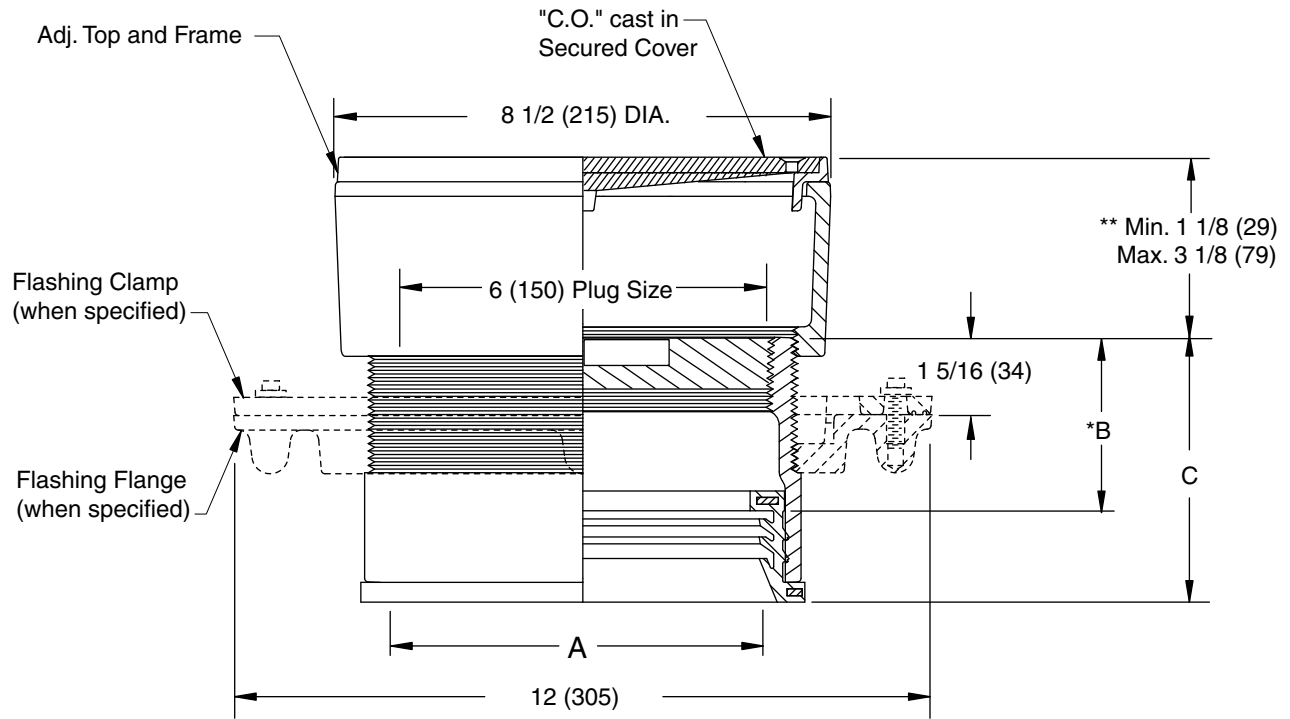

SPEEDI-SET OUTLET ▲

"A" (Pipe Size) = 06(150) & 08(200)

A SIZE	B	C
06(150)	*3(76)	4 9/16(117)
08(200)	*3 1/4(83)	4 13/16(121)

▲ Available in "L" Service Weight, "LXH" Extra Heavy or "LPVC" PVC or ABS. "LPVC" applicable to 06(150) Pipe Size only.
 * This Dimension to Internal Stop of Speedi-Set Gasket.
 ** When Flange-F is specified Min. 1 1/8 (29) becomes 1 5/8 (41)

"TWIS-TO-FLOOR" ADJUSTMENT

SPEEDI-SET OUTLET ▲

Fig. 4033L.....Taper Thread - Bronze Plug

REGULARLY FURNISHED:

Duco Cast Iron Cleanout with Taper Thread Bronze Plug and Round Adjustable Scoriated Secured Nickel Bronze Top.

VARIATIONS:

- Flashing Flange -F
- Flange with Flashing Clamp -F-C
- Carpet Clamping Type -X
- Carpet Marker Type -Y
- Vandal Proof Top -U
- Wide Flange (DX)

OPTIONAL MATERIALS:

- Galvanized Cast Iron -G
- Polished Bronze Top -PB

NOTE: Dimensions shown in parentheses are in millimeters.

DRAWING NUMBER
S4031BS

SIZE
A

SCALE:
NONE

DATE:
5-5-06

APPROVED BY:
CEL

CHECKED BY:
CL

DRAWN BY:
RN

FIGURE NUMBER
4033

WE CAN ASSUME NO RESPONSIBILITY FOR USE OF SUPERSEDED OR VOID DATA

REV.	DATE	DESCRIPTION	BY	CKD. BY

WEIGHT POUNDS	VOLUME CUBIC FEET

FIGURE NUMBER
4033