

## INSTALLATION INSTRUCTIONS FOR ELECTRONIC SENSOR ACTIVATED LAVATORY FAUCETS

*Solis™*

*Lino*



**EAF-275 Series**  
Solar Powered  
with Battery Backup  
Sensor Activated  
Lavatory Faucets



**EAF-250 Series**  
Battery Powered  
Sensor Activated  
Lavatory Faucets

**EAF-200 Series**  
Transformer Powered  
Sensor Activated  
Lavatory Faucets

(Models shown with ISM Integral Spout Mixer)

### LIMITED WARRANTY

Sloan Valve Company warrants its Optima EAF-275, EAF-250 and EAF-200 Series Electronic Hand Washing Faucets to be made of first class materials, free from defects of material or workmanship under normal use and to perform the service for which they are intended in a thoroughly reliable and efficient manner when properly installed and serviced, for a period of three years from date of purchase. During this period, Sloan Valve Company will, at its option, repair or replace any part or parts which prove to be thus defective if returned to Sloan Valve Company, at customer's cost, and this shall be the sole remedy available under this warranty. No claims will be allowed for labor, transportation or other incidental costs. This warranty extends only to persons or organizations who purchase Sloan Valve Company's products directly from Sloan Valve Company for purpose of resale. This warranty does not cover the life of the battery.

**THERE ARE NO WARRANTIES WHICH EXTEND BEYOND THE DESCRIPTION ON THE FACE HEREOF. IN NO EVENT IS SLOAN VALVE COMPANY RESPONSIBLE FOR ANY CONSEQUENTIAL DAMAGES OF ANY MEASURE WHATSOEVER.**

### PRIOR TO INSTALLATION

Prior to installing the Sloan Optima EAF-275/ EAF-250/EAF-200 Series faucets, install the items listed below. Also, refer to rough-in illustrations.

- Lavatory/sink
- Drain line
- Hot and cold water supply lines or pre-tempered water supply line

### IMPORTANT:

- ALL PLUMBING SHOULD BE INSTALLED IN ACCORDANCE WITH APPLICABLE CODES AND REGULATIONS.
- FLUSH ALL WATER LINES PRIOR TO MAKING CONNECTIONS.
- KEEP THREAD SEALANT OUT OF YOUR WATERWAY TO PREVENT COMPONENT PART DAMAGE! DO NOT USE ANY SEALANT ON COMPRESSION FITTINGS.

### Trim Plates

When the EAF faucet is installed on a sink that has three (3) hole punchings, a Trim Plate should be used. Trim Plates must be specified and ordered separately.

ETF-312-A Trim Plate for 4" (102 mm) Centerset Sink

ETF-510-A Trim Plate for 8" (203 mm) Centerset Sink

### TOOLS REQUIRED FOR INSTALLATION

- 13 mm open end wrench or nut driver for faucet retainer nut
- 3/4" open end wrench for female end of flex hose

## FAUCET ROUGH-IN

### SINGLE WATER SUPPLY

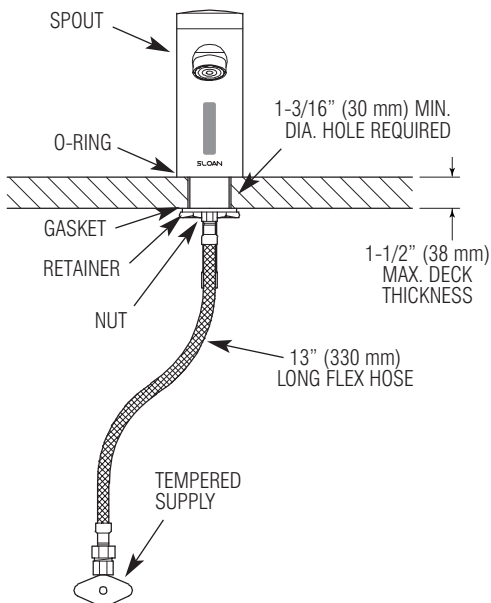

### HOT AND COLD WATER SUPPLY

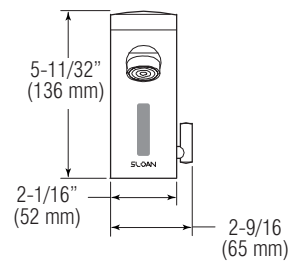
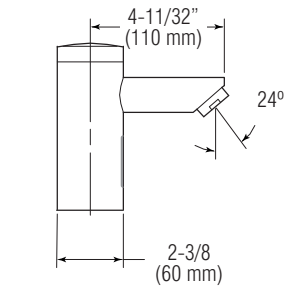
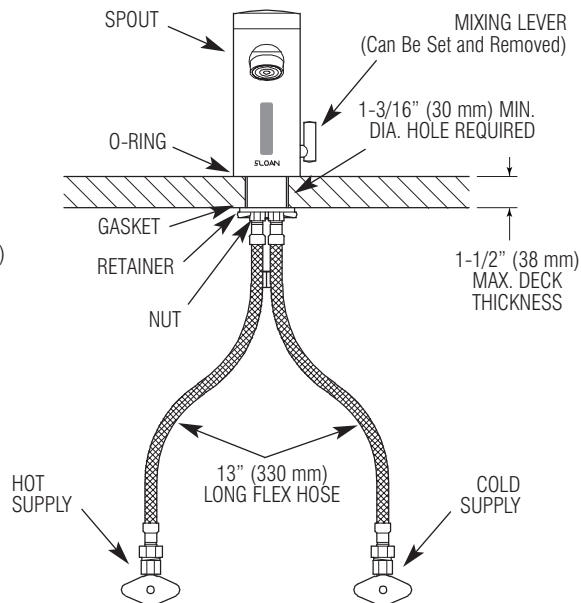

If a connection to separate hot and cold water supplies is desired, then a Bak-Chek® tee fitting (not supplied) must be used prior to connecting to the faucet.

# 1 Install Faucet.

- A** Remove Nut, Faucet Retainer and Gasket

Do Not remove the O-ring from base of faucet.

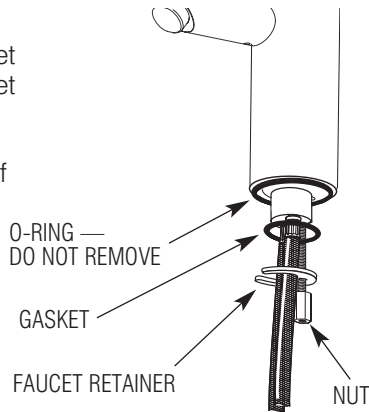

- B** Install Faucet with O-ring into the center hole in deck or lavatory — 1-3/16" (30 mm) min. hole required.

**Note:** If installing the faucet on a three (3) hole sink, a Trim Plate should be installed at this time.

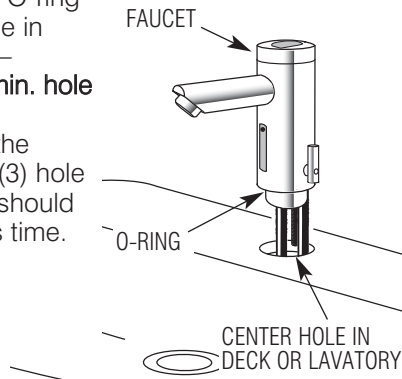

# 2 Slide Gasket over Flex Hose(s) and secure with Faucet Retainer and Nut.

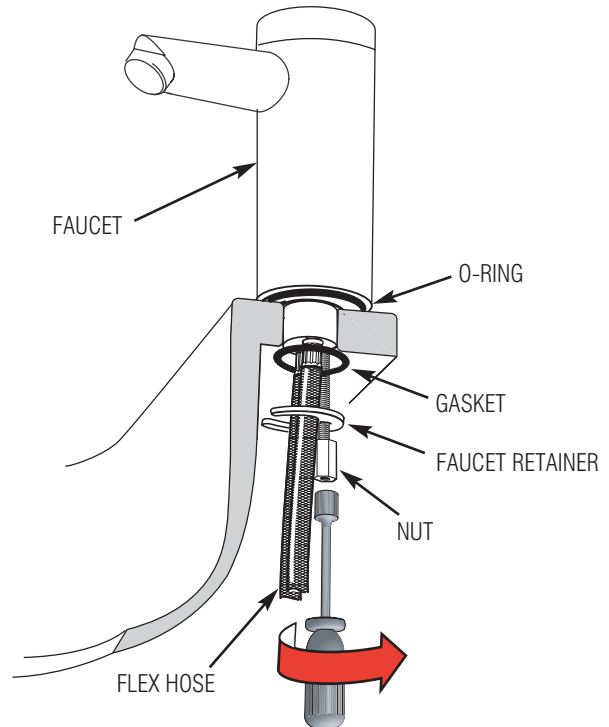

# 3 Install Strainer and Flex Hose onto Supply Stop.

**IMPORTANT:** Flush dirt, debris, and sediment from Supply Line(s) *before* Connecting Flex Hoses.

- A** Install Strainer and Flex Hose onto Supply Stop.



- B** Tighten the Flex Hose (with Strainer in place) securely to the Supply.

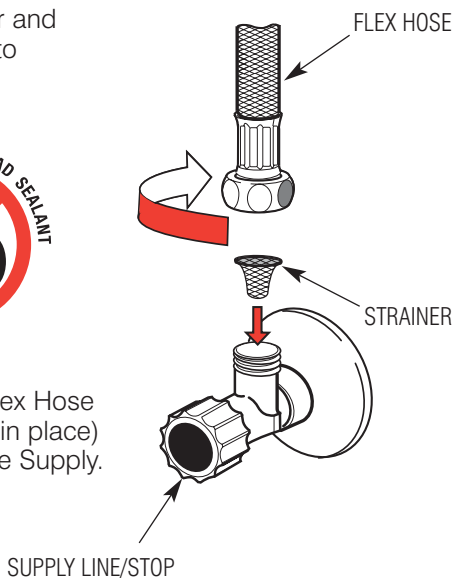

# 4 Open Supply Stops and Remove Sensor Label. Plug-in the Transformer (Model EAF-200 only).

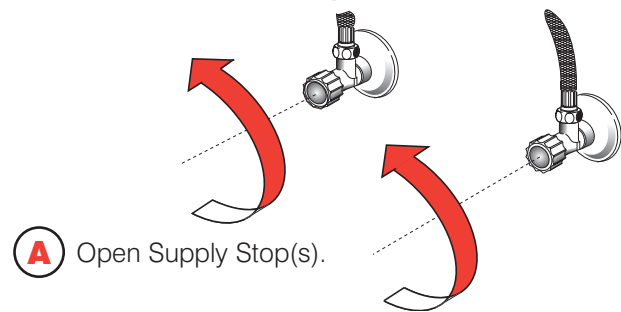

- A** Open Supply Stop(s).

- B** Remove Label from Sensor Window.

- C** For EAF-200 Models, Plug Transformer into receptacle.

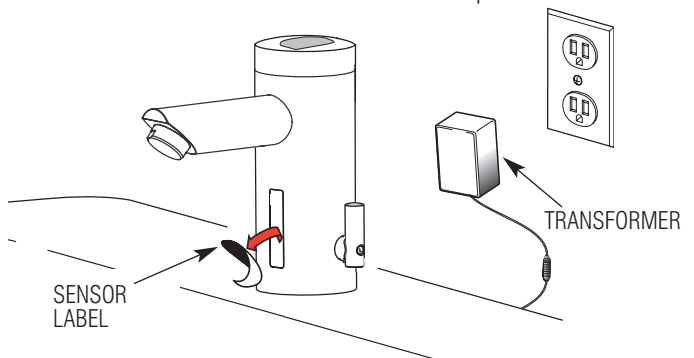

## 5 Activate Faucet.

- A** Activate Faucet, then immediately step away. Faucet will run for four (4) seconds and the range will automatically adjust to its environment. Wait ten (10) seconds after water shuts off before using Faucet.

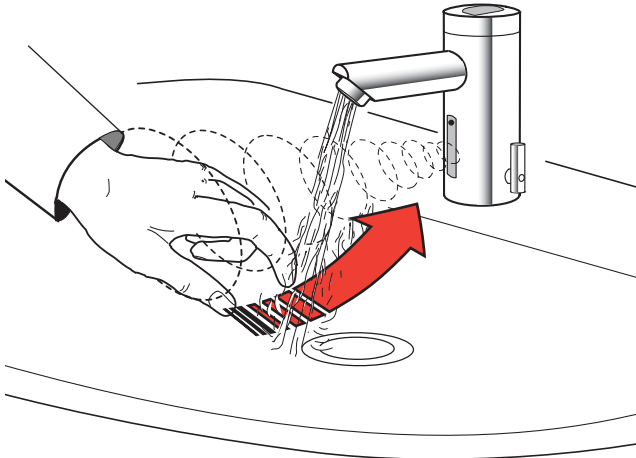

- B** Activate Faucet and check for leaks.

## 6 Set and Fix Temperature.

- A** Adjust lever to set temperature.

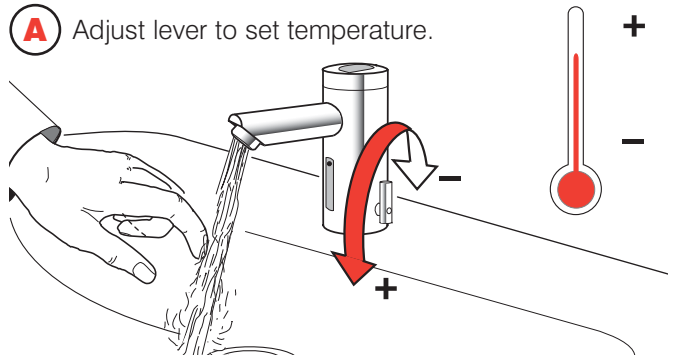

- B** To fix temperature, set lever to the desired position, then remove lever and plug hole with Cap.

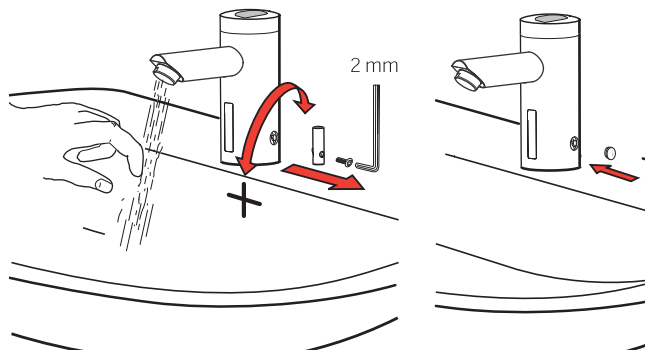

## 7 Battery Replacement

**NOTE:** Replace Battery when red LED indicator flashes each time faucet is in use or when faucet stops functioning.

- A** Close Supply Stop(s).

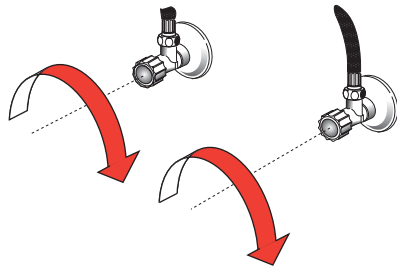

- B** Loosen Screw with hex wrench and remove Cap.

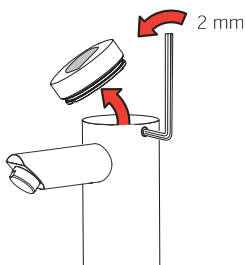

- C** Move Battery Retainer tab away from Battery. Remove old Battery. Dispose of properly.

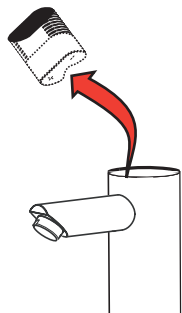

- D** Wait three (3) minutes before inserting new battery.



- E** Insert a new 6 Volt Type 2CR5 Lithium Battery. The red LED will flash for one (1) minute. Reinstall Battery Cover. If LED doesn't flash or if it just lights up, remove the Battery. Wait three (3) minutes, then reinsert the Battery. If water flows continuously after inserting the new Battery and opening the Supply Stops, remove the Battery. Wait three (3) minutes, then reinsert the Battery.

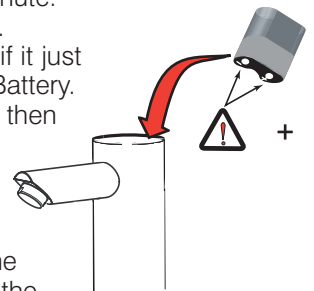

- F** Open Supply Stop(s).

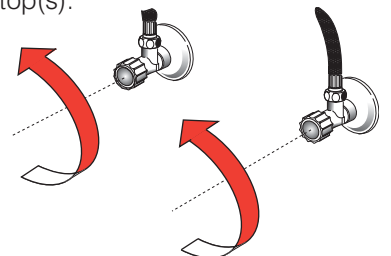

## 1.g-Click SETTINGS

Function	Press Button	LED Signal
Continuous Run — 2 minute default setting (adjustable from 1 - 20 minutes)	1 time for 2 seconds	5 short flashes
reset:	1 time or will reset automatically after 2 minutes	
Temporary Off	2 times (double click)	5 short flashes followed by periodic flashing
reset:	1 time or will reset automatically after 2 minutes	
Permanent Off	Consult Factory	Periodic flashing and then 2 long flashes
reset:	1 time	
Auto Set Range Adjustment	2 times (double click) and then 1 time for 5 seconds	5 short flashes followed by 4 short flashes

## TROUBLESHOOTING GUIDE

### 1. Problem: Faucet does not function.

*Cause:* Adhesive packaging label affixed over sensor eye.

*Solution:* Remove adhesive label from sensor eye.

*Cause:* "Permanent Off" activated.

*Solution:* Press button on faucet throat one time.

### 2. Problem: Faucet delivers water in an uncontrolled manner.

*Cause:* Faucet is defective.

*Solution:* Contact the Sloan Valve Company Installation Engineering Department (see below).

### 3. Problem: Faucet does not deliver any water when Sensor is activated.

**Indicator: Solenoid valve produces an audible "CLICK."**

*Cause:* Water supply stop(s) closed.

*Solution:* Open water supply stop(s).

*Cause:* Water supply stop strainer(s) clogged.

*Solution:* Remove, clean, and reinstall water supply stop strainer(s). Replace strainer(s) if required.

**Indicator: Solenoid valve DOES NOT produce an audible "CLICK."**

*Cause:* Battery low.

*Solution:* Replace battery (refer to Battery Replacement, Step 7).

### 4. Problem: Faucet delivers only a slow flow or dribble when Sensor is activated.

*Cause:* Water supply stop(s) are partially closed.

*Solution:* Completely open water supply stop(s).

*Cause:* Water supply stop strainer(s) clogged.

*Solution:* Remove, clean, and reinstall water supply stop strainer(s). Replace strainer(s) if required.

*Cause:* Aerator is clogged.

*Solution:* Remove, clean, and reinstall Aerator. Replace Aerator if required.

*Cause:* Faucet is defective.

*Solution:* Contact the Sloan Valve Company Installation Engineering Department (see below).

### 5. Problem: Faucet does not stop delivering water or continues to drip after user is no longer detected.

*Cause:* Valve is defective.

*Solution:* Contact the Sloan Valve Company Installation Engineering Department (see below).

### 6. Problem: LED indicator blinks when faucet is in use.

*Cause:* Battery low.

*Solution:* Replace battery (refer to Battery Replacement, Step 7).

### 7. Problem: The water temperature is too hot or too cold on a faucet connected to hot and cold supply lines.

*Cause:* Supply Stops are not adjusted properly.

*Solution:* Adjust Supply Stops.

*Cause:* For models with integral mixing valve — Mixing valve is set improperly for the water temperature desired.

*Solution:* Rotate mixing valve handle clockwise to decrease water temperature or counterclockwise to increase water temperature.

When assistance is required, please contact Sloan Valve Company Installation Engineering Department at:

**1-888-SLOAN-14: (1-888-756-2614) OR 1-847-233-2016**

## PARTS LIST

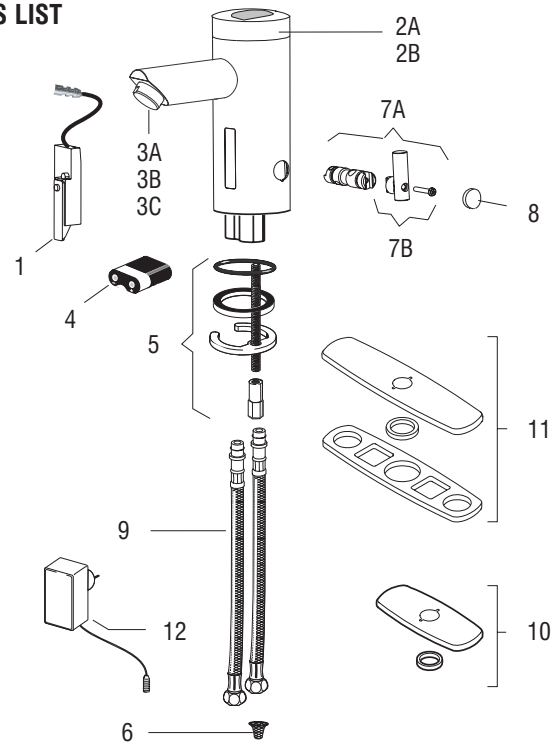

Item No.	Part No.	Description
1	EAF-14-A	Faucet Sensor Assembly
2A	EAF-1006	Cap and Solar Cell Assembly (EAF-275 only)
2B	EAF-27	Cap (EAF-250 and EAF-200 only)
3A	EAF-15	0.5 gpm (1.9 Lpm) VR Aerator Spray Head
3B	EAF-10	2.2 gpm (8.3 Lpm) Aerator Spray Head
3C	EAF-13	2.2 gpm (8.3 Lpm) Laminar Flow Spray Head
4	EAF-1003	Battery Replacement Kit
5	EAF-1	Faucet Mounting Kit
6	EAF-9	Strainer (Filter)
7A	EAF-1004	Mixer Handle Assembly and Cartridge
7B	EAF-1005	Handle Repair Kit
8	EAF-1007	Handle Cap
9	EAF-1008	13" (330 mm) Flexible Supply Hose
10	ETF-312-A	Trim Plate for 4" Centerset Sink
11	ETF-510-A	Trim Plate for 8" Centerset Sink
12	EAF-11	Transformer

## OPERATION

As the user's hands enter the beam's effective range, the beam is reflected back into the sensor receiver and activates the solenoid valve allowing water to flow from the faucet. Water will flow until the hands are removed or until the faucet reaches its automatic time out limit setting.

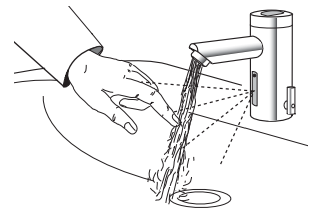

## CARE AND CLEANING OF CHROME AND SPECIAL FINISHES

DO NOT use abrasive or chemical cleaners (including chlorine bleach) to clean Faucets that may dull the luster and attack the chrome or special decorative finishes. Use ONLY mild soap and water, then wipe dry with clean cloth or towel.

While cleaning the bathroom tile, protect the Faucet from any splattering of cleaner. Acids and cleaning fluids will discolor or remove chrome plating.



The information contained in this document is subject to change without notice.

**SLOAN**

SLOAN VALVE COMPANY • 10500 Seymour Avenue • Franklin Park, IL 60131  
Phone: 1-800-9-VALVE-9 or 1-847-671-4300 • Fax: 1-800-447-8329 or 1-847-671-4380  
www.sloanvalve.com

Copyright © 2006 SLOAN VALVE COMPANY

Printed 08-06