

**For Residential and Commercial Applications**

Job Name		Engineer / Architect	
Job Location		Wholesaler	
Submittal Date		Contractor	

## 39 Series Flare Plugs

**Use:** For use with fuel, oil, liquefied petroleum (LP) and natural gas lines. Designed for use with aluminum, copper, brass and welded steel tubing that can be flared.

**Design Features:**

- **Recommended for higher pressures** than those covered by compression fittings
- **Resist mechanical pull out**
- **Available in a broad range of sizes**

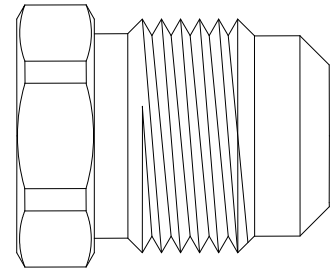

**Operating Specifications:**

- Temperature:** -65° - 250° F at maximum operating pressures
- Working Pressure:** see chart below
- Vibration:** Good vibration resistance\*



\*Recommend long flare nuts when greater vibration resistance is required

<b>MAXIMUM WORKING PRESSURES</b>											
Service Conditions	Tube O.D.	Type of Tubing and Wall Thickness (Inches)									
		Copper – Dead Soft (Seamless)					Copper – Half Hard (Seamless)				
		.030"	.032"	.035"	.049"	.065"	.032"	.035"	.042"	.049"	.065"
Safety Factor 4-1	1/8	4300		5000			5000				
	3/16	2850		3300			3400				
	1/4	2100	2250	2500			2500				
	5/16		1800	2000			2000				
	3/8		1500	1650			1700	1850			
	1/2		1100	1250		2000	1250	1400			2600
	5/8			1000	1400	1800	1000			1500	2000
	3/4			850	1150	1500			1100		1700
	7/8									1100	1500
Safety Factor 6-1	1/8	2800		3350			3400				
	3/16	1900		2200			2250				
	1/4	1430	1500	1650			1700				
	5/16		1200	1300			1350				
	3/8		100	1100			1100	1200			
	1/2		750	825		1550	850	925			1750
	5/8			650	930	1200	675			1000	1350
	3/4			550	775	1000			725		1100
	7/8									750	1000

*This specification and all information contained herein is the confidential and exclusive property of BrassCraft Manufacturing, and shall not be disclosed to others without the written consent of BrassCraft. This specification must be returned to BrassCraft if requested.*



# 39 Series Flare Plugs

MATERIAL SPECIFICATIONS	
Flare Plug	C36000 brass

PART DIMENSIONS (Inches)			
Model	Straight Threads	DIM. A	HEX. B
39-4	7/16-20	.69	7/16
39-5	1/2-20	.78	1/2
39-6	5/8-18	.88	5/8
39-8	3/4-16	1.06	3/4
39-10	7/8-14	1.19	7/8

**Part Listing:**

- 39-4 For 1/4" OD Tube
- 39-4 B For 1/4" OD Tube, bulk
- 39-5 For 5/16" OD Tube
- 39-6 For 3/8" OD Tube
- 39-6 B For 3/8" OD Tube, bulk
- 39-8 For 1/2" OD Tube
- 39-8 B For 1/2" OD Tube, bulk
- 39-10 For 5/8" OD Tube
- 39-10 B For 5/8" OD Tube, bulk

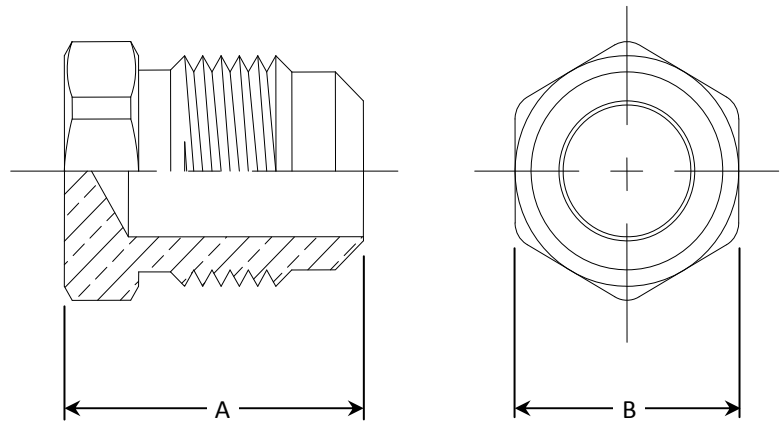

*This specification and all information contained herein is the confidential and exclusive property of BrassCraft Manufacturing, and shall not be disclosed to others without the written consent of BrassCraft. This specification must be returned to BrassCraft if requested.*

**BrassCraft**<sup>®</sup>