

Product data sheet

Specifications

SQUARE D

Green Premium™



Mini circuit breaker, QO, 50A, 2 pole, 120/240VAC, 10kA, bolt on mount

QOB250

Product availability : Stock - Normally stocked in distribution facility

Price* : 91.54 USD

Main

Product	Miniature circuit-breaker
Range	QO
Current Rating	50 A
Voltage Rating	120/240 V AC 120 V AC
Mounting Type	Bolt-on
Number of Poles	2P
Circuit Breaker Type	Standard
Ratings	HACR rated
Electrical Connection	Box lugs

Complementary

Interrupt Rating	10 kA 120/240 V AC 50/60 Hz 10 kA 120 V AC 50/60 Hz
Number of Panel Spaces	2
Wire Size	AWG 8...AWG 2 copper or aluminium
Tightening Torque	44.25 lbf.in (5 N.m) 0.02...0.04 in ² (10...25 mm ²) (AWG 8...AWG 2)
Height	3.11 in (79 mm)
Width	1.50 in (38 mm)
Depth	2.91 in (74 mm)
Net Weight	0.55 lb(US) (0.249 kg)

Environment

Certifications	UL Listed CSA
Ambient Rating	104 °F (40 °C)

Ordering and shipping details

Category	00015-QOB CIRCUIT BREAKERS
Discount Schedule	DE2

* Price is "List Price" and may be subject to a trade discount – check with your local distributor or retailer for actual price.

GTIN	785901416982
Returnability	Yes
Country of origin	MX

Packing Units

Unit Type of Package 1	PCE
Number of Units in Package 1	1
Package 1 Height	1.50 in (3.81 cm)
Package 1 Width	3.30 in (8.382 cm)
Package 1 Length	3.50 in (8.89 cm)
Package 1 Weight	4.00 oz (113.398 g)
Unit Type of Package 2	BB1
Number of Units in Package 2	5
Package 2 Height	3.40 in (8.636 cm)
Package 2 Width	2.70 in (6.858 cm)
Package 2 Length	7.70 in (19.558 cm)
Package 2 Weight	2.96 lb(US) (1.343 kg)
Unit Type of Package 3	CAR
Number of Units in Package 3	50
Package 3 Height	8.10 in (20.574 cm)
Package 3 Width	7.60 in (19.304 cm)
Package 3 Length	17.20 in (43.688 cm)
Package 3 Weight	30.35 lb(US) (13.767 kg)

Offer Sustainability

Sustainable offer status	Green Premium product
California proposition 65	WARNING: This product can expose you to chemicals including: Nickel compounds, which is known to the State of California to cause cancer. For more information go to www.P65Warnings.ca.gov
REACH Regulation	REACH Declaration
EU RoHS Directive	Compliant EU RoHS Declaration
Toxic heavy metal free	Yes
Mercury free	Yes
China RoHS Regulation	China RoHS declaration Product out of China RoHS scope. Substance declaration for your information.
RoHS exemption information	Yes
Halogen content performance	Halogen free product

Contractual warranty

Warranty	18 months
----------	-----------

Dimensions

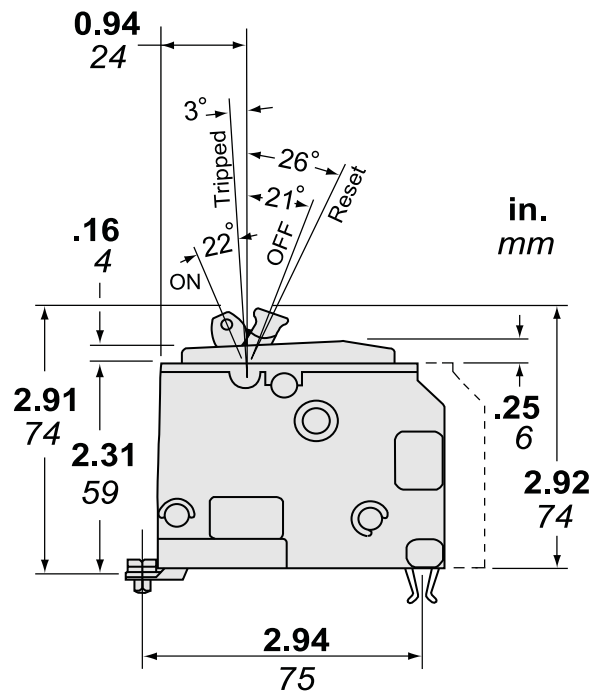
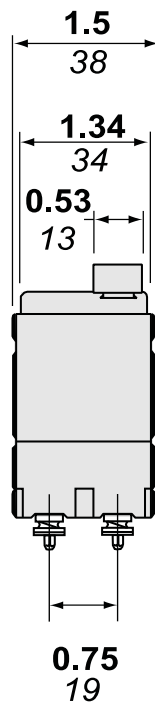
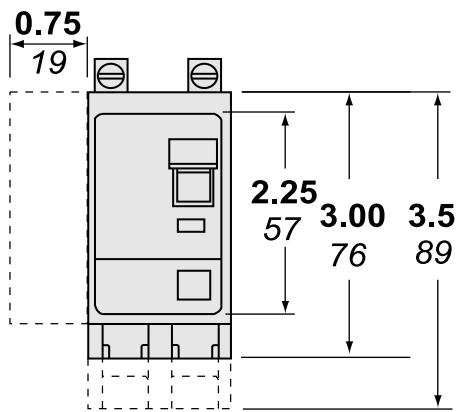

Dimensions are approximate. Refer to technical documentation for additional detail.

Recommended replacement(s)