



# UT CONTROL BOARD 62-24084-82

THIS REPLACEMENT IS USED ON THE FOLLOWING FURNACES. [-]GRA, [-]GSA, [-]GTA, [-]GZC, [-]GZD 90+ Furnaces with **Hot Surface Ignition**. Also repairs Models [-]GDG, [-]GLH, [-]GPH, [-]GVH 80+ Furnaces with **Hot Surface Ignition**. Please note that units built before "3294" may require the addition of a [ 62-24044-71 ] Flame Sensor Kit ordered separately.

This MASTER REPLACEMENT PART replaces the following Control Boards:

62-22694-01	62-22694-82	62-22737-08	62-24044-81	62-24084-02
62-22694-02	62-22694-83	62-22737-10	62-24044-91	62-24084-71
62-22694-03	62-22694-91	62-22737-87	62-24045-01	62-24084-82
62-22694-11	62-22737-06	62-22737-88	62-24046-01	62-24084-91
62-22694-12	62-22737-07	62-24044-01	62-24084-01	62-24084-92

*In the event your system has DSI or Direct Spark Ignition, You must order part number 62-24140-02 control board. Use the first 2 Letters of the units serial number to determine if it is HSI - Hot Surface Ignition or DSI - Direct Spark Ignition.*

### UNIT SERIAL NUMBER FORMULA (EXAMPLE)

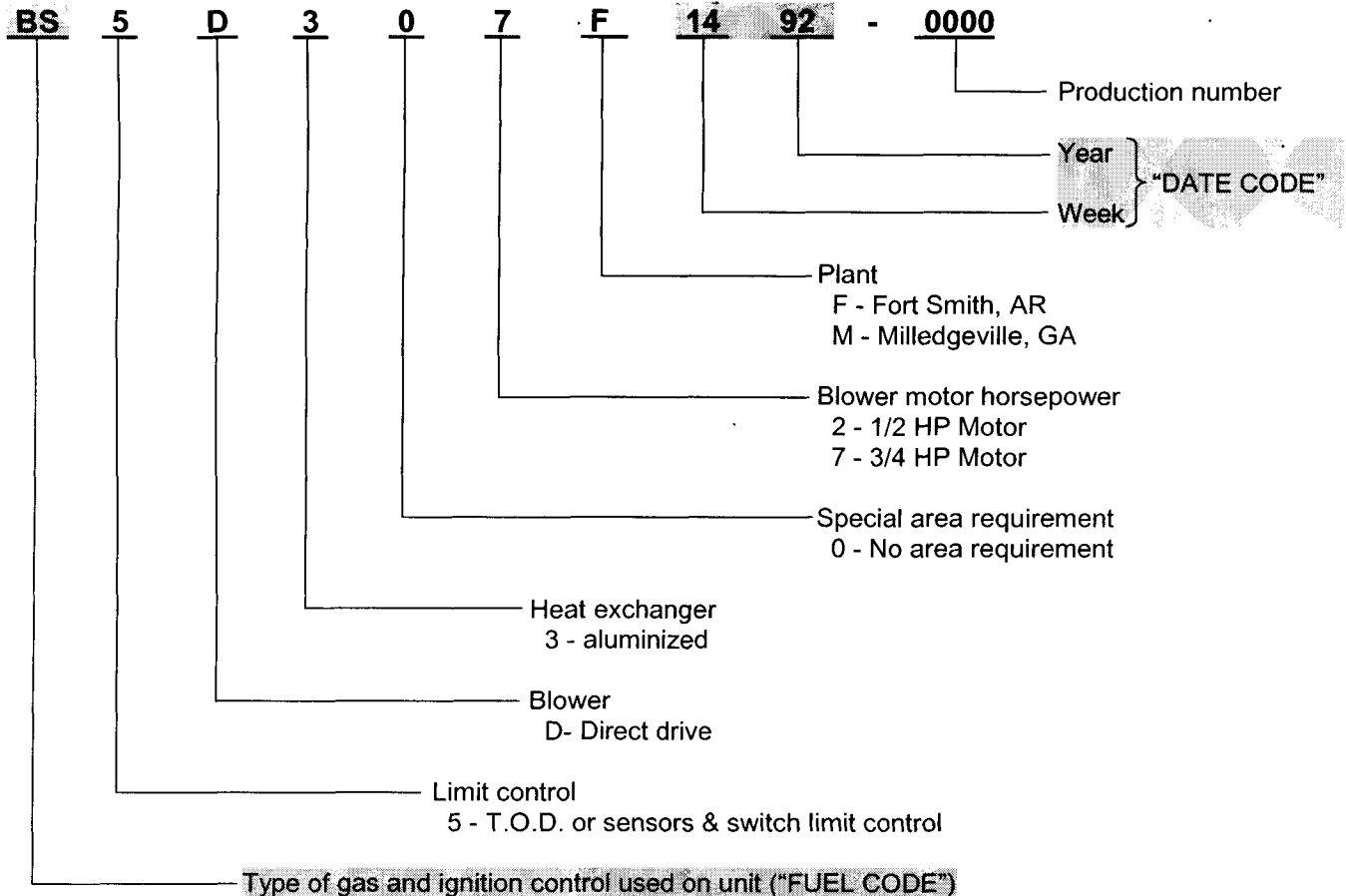

**MENU:**

The following MENU gives instructions to replace the control board on:

1. Units which have *NOT* been converted to Remote Flame Sense.
  - A. Normal Installation - See pages 3, 6 and 7.
  - B. Twinned Units - See pages 3, 4, 5, 6, 7 and 8.
  - C. Fossil Fuel Kits - See pages 3, 6, 7 and 8-D.
  - D. Twinned Units with Fossil Fuel Kits - See pages 3, 4, 5, 6, 7 and 8-E.
  
2. Units which have Remote Flame Sense installed at the Factory
  - A. Normal Installation - See pages 3 and 8-A.
  - B. Twinned Units - See pages 2, 3, 4 and 8-C.
  - C. Fossil Fuel Kits - See pages 3 and 8-D.
  - D. Twinned Units with Fossil Fuel Kits - See pages 3, 4, 5, 6, 7 and 8-E.
  
3. Units which have been converted to Remote Flame Sense by installing Remote Sense Kit 62-24044-71
  - A. Normal Installation - See pages 3 and 8-B.
  - B. Twinned Units - See pages 3, 4, 5, 6, 7 and 8-C.
  - C. Fossil Fuel Kits - See pages 3 and 8-D.
  - D. Twinned Units with Fossil Fuel Kits - See pages 3, 4, 5, 6, 7 and 8-E.

---

**TABLE OF CONTENTS**

	<b>PAGE</b>
Title Page . . . . .	1
Serial Number Explanation. . . . .	1
Table of Contents . . . . .	2
Menu . . . . .	2
Installation Instructions . . . . .	3
Twining - Single Stage. . . . .	4
Twining - Two Stage . . . . .	4
Twining - Wire Assembly. . . . .	5
Remote Flame Sensor Add-On Kit . . . . .	6-7

**SPECIAL INSTRUCTIONS**

Factory Installed Remote Flame Sense . . . . .	8 - A
Field Installed Remote Sense . . . . .	8 - B
Twinned Units . . . . .	8 - C
Fossil Fuel Kits . . . . .	8 - D
Twinned Fossil Fuel Kits . . . . .	8 - E

# INSTRUCTIONS FOR NORMAL INSTALLATIONS

## WARNING

**TURN OFF ELECTRICAL POWER TO THE FURNACE BEFORE BEGINNING ANY MAINTENANCE. FAILURE TO DO SO CAN CAUSE ELECTRICAL SHOCK RESULTING IN SEVERE PERSONAL INJURY OR DEATH.**

### 1. REPLACING UT BOARD WITH UT BOARD

- A. No field modifications required.
- B. Set Blower Off Timing same as the old board or see sketch below for settings.

### 2. REPLACING HONEYWELL BOARD WITH UT BOARD.

- A. Terminal locations are different but functionally the same. (This is also true for some UT boards).
- B. Set Blower Off Timing per sketch below. Replacement board is factory preset to 120 seconds.

**NOTE: Install Boards Gently By Pressing In On Mounting Clip/Stand, Instead of Putting Pressure On The Body Of Control Board.**

**UTEC-920A  
BLOWER OFF TIMINGS**

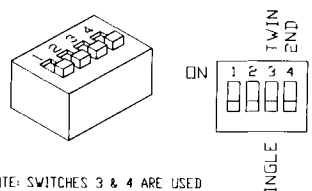

NOTE: SWITCHES 3 & 4 ARE USED FOR TWINNING APPLICATIONS.

OFF TIMER	SWITCH 1	SWITCH 2
90 SEC.	OFF	ON
120 SEC.	OFF	OFF
160 SEC.	ON	OFF
180 SEC.	ON	ON

The UT 1012-920 Control Boards have four "Quick-Connect" terminals for connecting the motor speed leads. These are:

1. FAN - Motor runs on this speed when the thermostat is in the continuous "FAN ON" position.
2. COOL - Connect to desired cooling speed.
3. HEAT - Connect to desired heating speed.
4. HEAT/COOL - Connect desired speed when heating and cooling speed are the same

**IMPORTANT: DO NOT CONNECT ANY MOTOR SPEEDS TO "HEAT" AND/OR "COOL" IF YOU USE THE "HEAT/COOL" TERMINAL.**

5. If heating and continuous fan speed are the same, connect a "piggy-back" jumper across "FAN" and "HEAT"

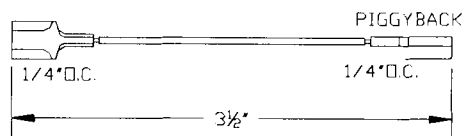

# INSTRUCTIONS USING TWINNED FURNACES (SINGLE STAGE HEAT)

## 1. REPLACING HONEYWELL BOARD WITH UT BOARD

- A. When furnaces are twinned, they "MUST" use the same control boards. Therefore, replace both boards with UT 62-24084-82.
- B. Remove (2) wires from "XMIT" to "RCV" and "RCV" to "XMIT" on H/W boards.
- C. Remove wire from "GND" to "GND" on Honeywell boards.
- D. Connect low voltage wire from "C" to "C" on UT boards.
- E. Connect low voltage wire from "TWIN" terminal on UT board to "TWIN" terminal on (2nd) UT board.
- F. Connect low voltage wire from "W" terminal on UT board to "W" terminal on (2nd) UT board.
- G. Reference wiring diagram on page 5 for remaining connections. NOTE: Terminals W, Y, G, R, C on UT boards are in different sequence on H/W boards.
- H. Adjust Heat Anticipator Current for 0.2 amps, then set Blower Off Timings per 1B or 2B on page 3.
- I. Set twining DIP switches 3 and 4 to "TWIN" and "1st" on both controls.

---

# INSTRUCTIONS USING TWINNED FURNACES (TWO STAGE HEAT)

## 1. REPLACING H/W BOARD WITH UT BOARD

- A. When furnaces are twinned, they "MUST" use the same control boards. Therefore, replace both boards with UT 62-24084-82.
- B. Remove (2) wires from "XMIT" to "RCV" and "RCV" to "XMIT" on H/W boards.
- C. Remove wire from "GND" to "GND" on Honeywell boards.
- D. Connect low voltage wire from "C" to "C" on UT boards.
- E. Connect low voltage wire from "TWIN" terminal on UT board to "TWIN" terminal on (2nd) UT board.
- F. Connect "W1" of thermostat to "W" of UT Control Board connected to thermostat.
- G. Connect "W2" of thermostat to "W" of (2nd) UT Control board.
- H. Reference wiring diagram on page 5 for remaining connections. NOTE: Terminals W, Y, G, R, C on UT boards are in different sequence on H/W boards.
- I. Adjust heat anticipator current for 0.1 amps on each stage of heating, then set Blower Off Timings per 1B or 2B on page 3.
- J. Set twining DIP switches 3 and 4 to "TWIN" and "1st" on 1st control, and "TWIN" and "2nd" on 2nd control.

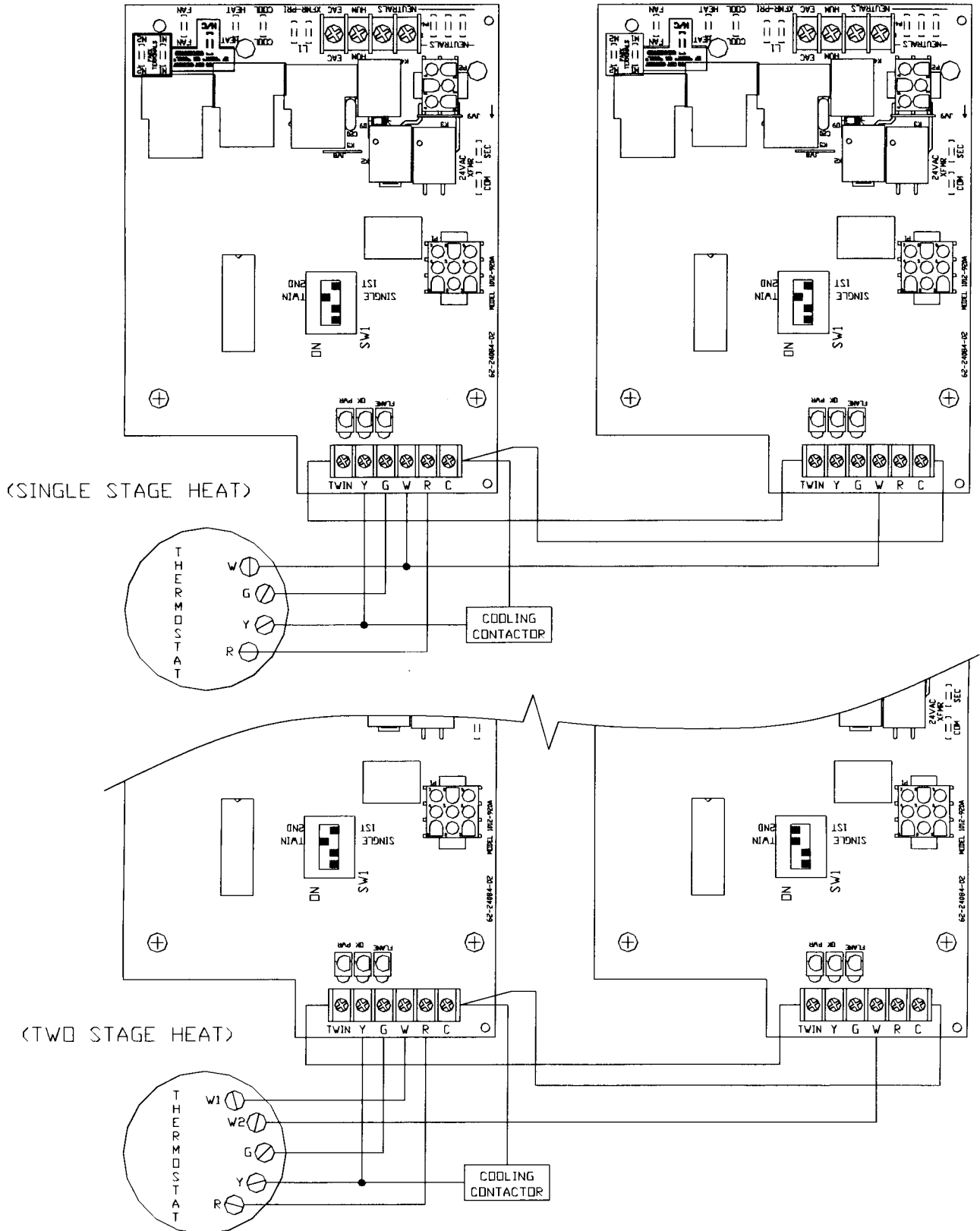

CAUTION MUST BE USED TO FOLLOW ALL INSTRUCTIONS. UNIT'S OPERATION MUST BE CHECKED FOR PROPER PERFORMANCE AFTER THE REPAIR IS MADE. IN THE EVENT THERE ARE ANY QUESTIONS, CONTACT YOUR LOCAL DISTRIBUTOR OR SERVICE REPRESENTATIVE.

# ADDING REMOTE FLAME SENSOR 62-24044-71 (ORDERED SEPARATELY)

## **WARNING**

**TURN OFF ELECTRICAL POWER TO THE FURNACE BEFORE BEGINNING ANY MAINTENANCE. FAILURE TO DO SO CAN CAUSE ELECTRICAL SHOCK RESULTING IN SEVERE PERSONAL INJURY OR DEATH.**

1. Remove all necessary covers and panels to gain access to the burners.

NOTE: THIS KIT IS DESIGNED TO BE INSTALLED WITH BURNERS AND GAS ASSEMBLY IN PLACE.

2. The 34" Low Profile furnace uses "inshot" bracket (AE-57974-01) with two holes on the front, see bracket below.

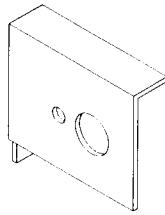

FIGURE 1

3. The sensor bracket mounts to the burner as shown in Figure 2. Position the bracket on the appropriate side of the burner support and align the two holes. NOTE: The flat flange on the bracket must be AWAY FROM THE BURNERS.
4. Insert the screws through the holes in the burner bracket and tighten with a ratchet wrench and 1/4 socket. See Figure 2.
5. Insert the sensor (62-23543-01) through the hole in the bracket. Use a 1/4" nut driver to anchor the sensor with one of the sheet metal screws provided. The sensor rod should pass diagonally in front of the burner, as shown. See Figure 3.

**IMPORTANT: DO NOT ALLOW THE SENSOR ROD TO TOUCH ANY FURNACE COMPONENT.**

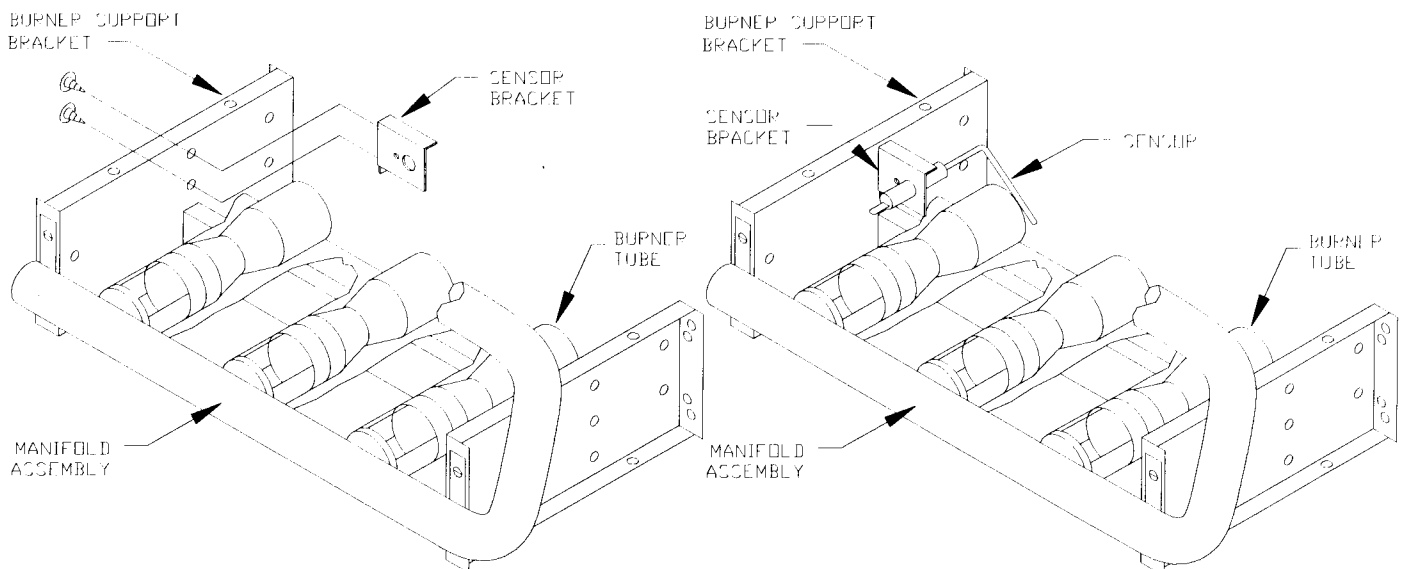

FIGURE 2

FIGURE 3

6. Insert the 19" orange wire in the corner socket between the red and blue wire. The quick connect end of this wire goes to the remote flame sensor. (See diagram below.)
7. Insert the ends of the 28" orange wire in the corner between red and blue wire of both plugs. (See diagram below.)
8. Stick the new wiring diagram label over the old wiring diagram located on the inside of the control box cover.

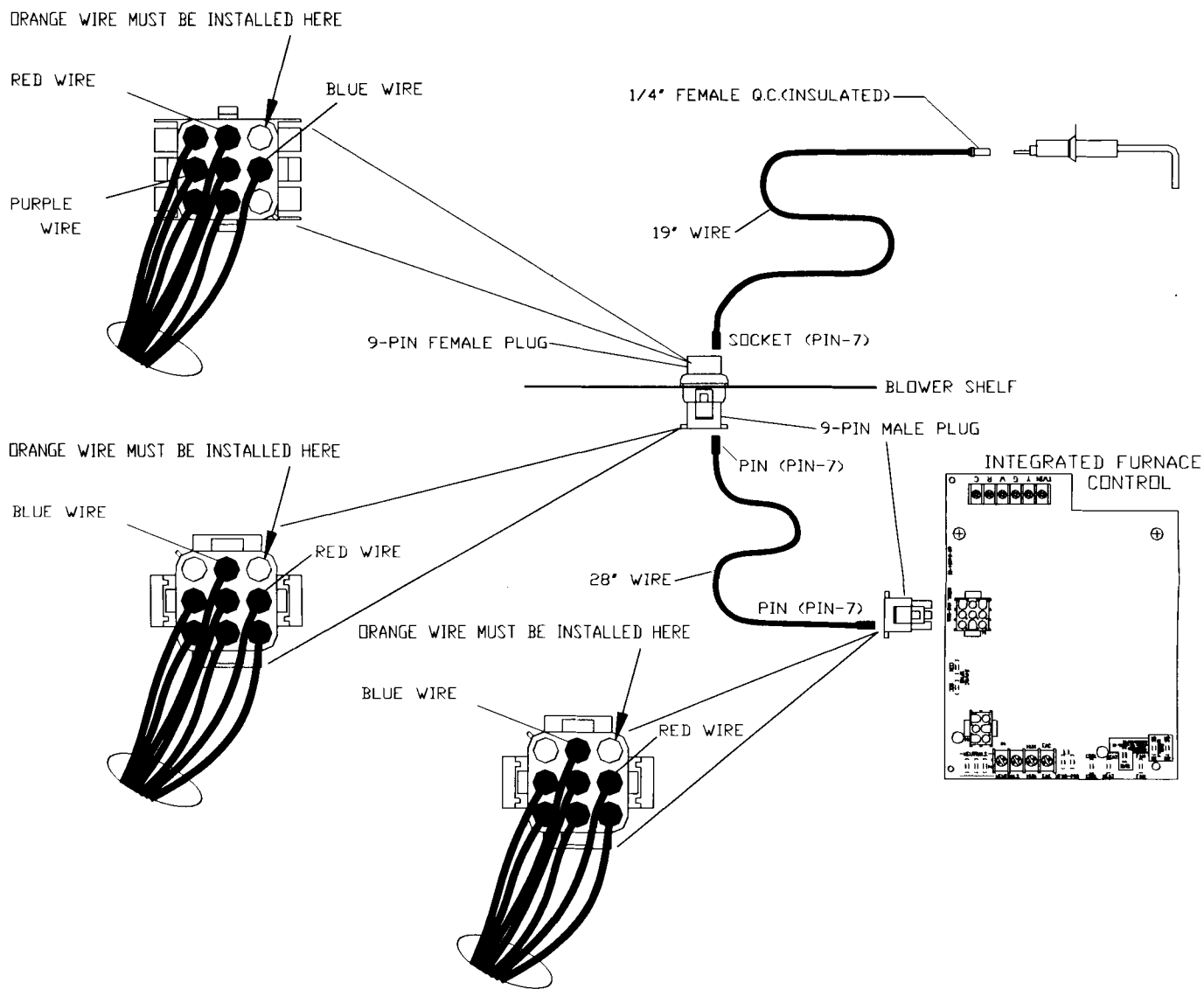

FIGURE 4. TYPICAL UPFLOW FURNACE

# SPECIAL INSTRUCTIONS

---

## A. REMOTE SENSOR INSTALLED AT THE FACTORY:

1. Disconnect the wire to the Remote Sensor.
  2. Use Wire Ties to secure the old Remote Sensor lead.
  3. Install the new Remote Sensor wiring as outlined on page 7, Steps 6 through 9.
- 

## B. REMOTE SENSOR ADDED BY KIT 62-24044-71

1. Disconnect the wire from the Remote Sensor and from the Splice at HSI power supply wire.
  2. Leave the insulated Splice in place on HSI power supply wire.
  3. Discard the old Remote Sensor wire.
  4. Install the new Remote Sensor wiring as outlined on page 7, Steps 6 through 9.
- 

## C. TWINNED UNITS:

1. Replace both control boards as outlined on page 3 and 4.
  2. Interconnect the two control boards as shown on page 5.
  3. Make Thermostat connections to the "Master" control as shown on page 5.
- 

## D. FOSSIL FUEL KITS:

1. Control is compatible with Fossil Fuel Kits RXPF-E01, RXPF-F01, and RXPF-F02
2. Replace the control board as outlined on page 3.
3. Wire the Thermostat connections in accordance with the Heat Pump System Wiring Schematics. **Terminal locations on the control may be different, but are functionally the same.** (If desired, an RXPF-C01 or RXPF-E01 may be field converted to an RXPF-F01. The system components are the same, but the wiring is different.)

References for Fossil Fuel Kit Information:

92-21779-08 Typical Remote Heat Pump System Wiring Schematics

92-20871-23 Installation Instructions for Fossil Fuel Kits RXPF-F01 and RXPF-F02

92-20871-16 Installation Instructions for Fossil Fuel Kits RXPF-C01, RXPF-D02 and RXPF-E01

---

## E. TWINNED UNITS WITH FOSSILE FUEL KITS:

1. Replace both control boards as outlined on page 3 and 4.
2. Interconnect the two control boards as shown on page 5.
3. Wire the Thermostat connections in accordance with the Heat Pump System Wiring Schematics. Terminal locations on the control may be different, but are functionally the same. See Fossil Fuel Kit information above. Make the Thermostat connections to the "Master" control as shown on page 5.