

# PARTS MANUAL



## **MODEL QP2TH TRASH PUMP (HONDA GX160K1QX2/GX160U1QX2/GX160UT2QX2 GASOLINE ENGINE)**

Revision #8 (05/29/20)

To find the latest revision of this publication or associated operation manual, visit our website at: [www.multiquip.com](http://www.multiquip.com)



**THIS MANUAL MUST ACCOMPANY THE EQUIPMENT AT ALL TIMES.**



**QP2TH Trash Pump**

Explanation Of Code In Remarks Column..... 4  
Suggested Spare Parts ..... 5

**Component Drawings**

Pump Assembly..... 6-9  
Engine Service Parts..... 10-11

**NOTICE**

Specifications and part numbers are subject to change without notice.

# EXPLANATION OF CODE IN REMARKS COLUMN

The following section explains the different symbols and remarks used in the Parts section of this manual. Use the help numbers found on the back page of the manual if there are any questions.

**NOTICE**

The contents and part numbers listed in the parts section are subject to change **without notice**. Multiquip does not guarantee the availability of the parts listed.

## SAMPLE PARTS LIST

NO.	PART NO.	PART NAME	QTY.	REMARKS
1	12345	BOLT .....	1	INCLUDES ITEMS W/%
2%		WASHER, 1/4 IN. ....		NOT SOLD SEPARATELY
2%	12347	WASHER, 3/8 IN. ...	1	MQ-45T ONLY
3	12348	HOSE .....	A/R	MAKE LOCALLY
4	12349	BEARING .....	1	S/N 2345B AND ABOVE

## NO. Column

**Unique Symbols** — All items with same unique symbol (@, #, +, %, or >) in the number column belong to the same assembly or kit, which is indicated by a note in the “Remarks” column.

**Duplicate Item Numbers** — Duplicate numbers indicate multiple part numbers, which are in effect for the same general item, such as different size saw blade guards in use or a part that has been updated on newer versions of the same machine.

**NOTICE**

When ordering a part that has more than one item number listed, check the remarks column for help in determining the proper part to order.

## PART NO. Column

**Numbers Used** — Part numbers can be indicated by a number, a blank entry, or TBD.

TBD (To Be Determined) is generally used to show a part that has not been assigned a formal part number at the time of publication.

A blank entry generally indicates that the item is not sold separately or is not sold by Multiquip. Other entries will be clarified in the “Remarks” Column.

## QTY. Column

**Numbers Used** — Item quantity can be indicated by a number, a blank entry, or A/R.

A/R (As Required) is generally used for hoses or other parts that are sold in bulk and cut to length.

A blank entry generally indicates that the item is not sold separately. Other entries will be clarified in the “Remarks” Column.

## REMARKS Column

Some of the most common notes found in the “Remarks” Column are listed below. Other additional notes needed to describe the item can also be shown.

**Assembly/Kit** — All items on the parts list with the same unique symbol will be included when this item is purchased.

Indicated by:

“INCLUDES ITEMS W/(unique symbol)”

**Serial Number Break** — Used to list an effective serial number range where a particular part is used.

Indicated by:

“S/N XXXXX AND BELOW”

“S/N XXXX AND ABOVE”

“S/N XXXX TO S/N XXX”

**Specific Model Number Use** — Indicates that the part is used only with the specific model number or model number variant listed. It can also be used to show a part is NOT used on a specific model or model number variant.

Indicated by:

“XXXXX ONLY”

“NOT USED ON XXXX”

**“Make/Obtain Locally”** — Indicates that the part can be purchased at any hardware shop or made out of available items. Examples include battery cables, shims, and certain washers and nuts.

**“Not Sold Separately”** — Indicates that an item cannot be purchased as a separate item and is either part of an assembly/kit that can be purchased, or is not available for sale through Multiquip.

## SUGGESTED SPARE PARTS

### QP2TH TRASH PUMP WITH HONDA GX160K1QX2/GX160U1QX2/ GX160UT2QX2 ENGINES

1 to 3 units

Qty.	P/N	Description
1.....	1889040030.....	IMPELLER
1.....	0811345443.....	MECHANICAL SEAL SLEEVE
2.....	0803442930.....	MECHANICAL SEAL
2.....	0631211159.....	CAP, FLOODING
2.....	0481571950.....	O-RING, DRAIN COVER
2.....	0489402910.....	O-RING, CASING
2.....	0482200180.....	O-RING, MECHANICAL SEAL SLEEVE
4.....	0852833020.....	ADJUST LINER .30
4.....	0852853020.....	ADJUST LINER .50
3.....	17210ZE2515.....	ELEMENT, AIR CLEANER, GX160K1QX2/GX160U1QX2
3.....	17210ZE1517.....	ELEMENT, AIR CLEANER, GX160UT2QX2
3.....	9807956846.....	SPARK PLUG
1.....	28462ZE2W11.....	ROPE, RECOIL STARTER, GX160K1QX2/GX160U1QX2
1.....	28462ZH8003.....	ROPE, RECOIL STARTER, GX160UT2QX2
1.....	17620ZH7023.....	CAP, WITH GASKET, FUEL FILLER, GX160K1QX2/GX160U1QX2
1.....	17620Z4M000.....	CAP, WITH GASKET FUEL FILLER, GX160UT2QX2

#### NOTICE

Part numbers on this Suggested Spare Parts list may supersede/replace the part numbers shown in the following parts lists.

# PUMP ASSEMBLY

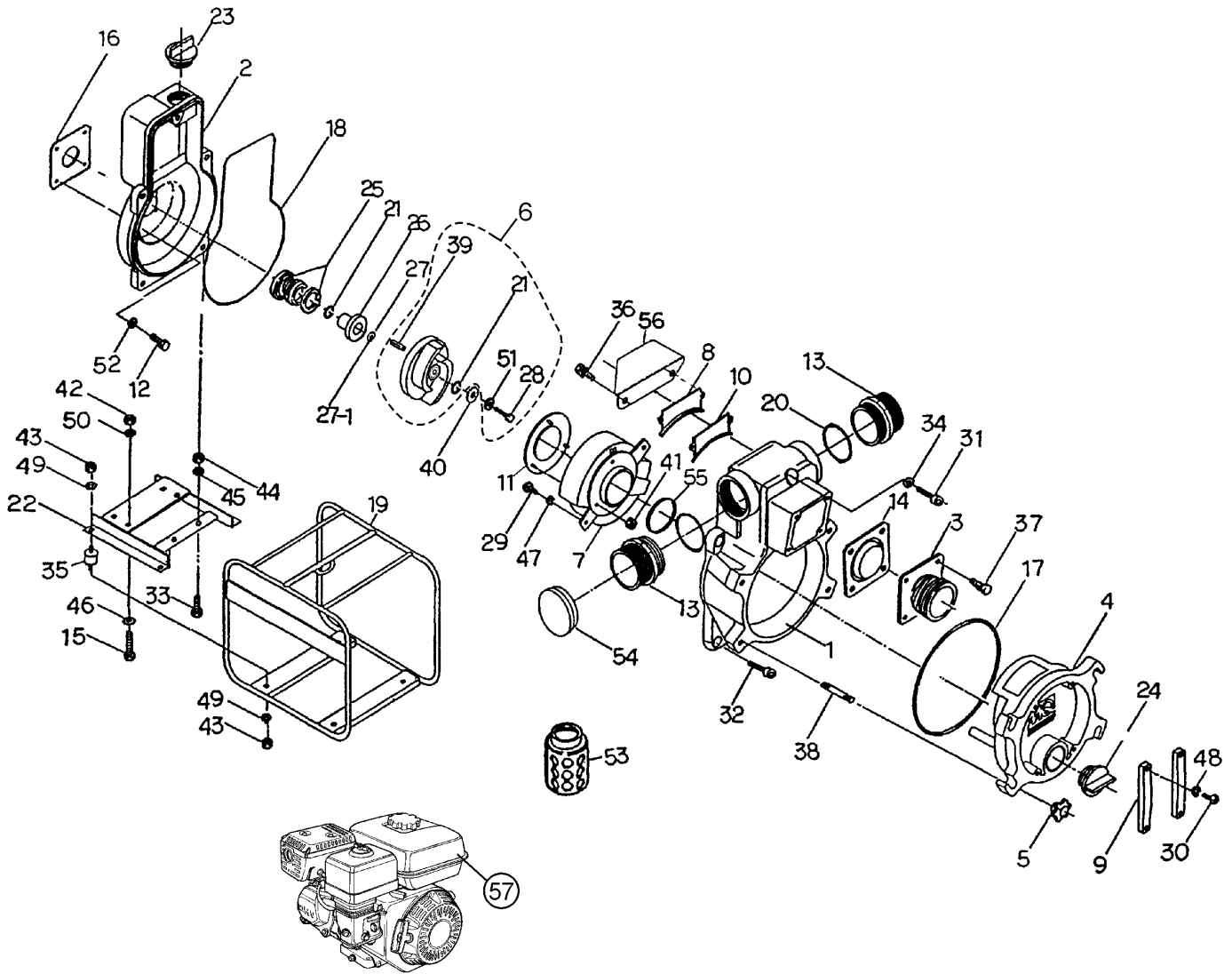

## PUMP ASSEMBLY

NO.	PART NO.	PART NAME	QTY.	REMARKS
1	1889100011	CASING	1	
2	1889100020	CASING COVER	1	
3	18890001600014	SUCTION COVER	1	
4	1889100171	DRAIN COVER	1	
5	19920002200014	DRAIN COVER HANDLE	4	
6	1889040031ASSY	IMPELLER KIT.....	1	INCLUDES ITEMS W/ #
7	1889000132	VOLUTE CASING	1	
8	1889100741	SUCTION PLATE	1	
9	1247100250	DRAIN COVER SET HANDLE	2	
10	1889330410	SUCTION PLATE PACKING	1	
11	1992250700	WEAR PLATE	1	
12	0191190525	BOLT(CASING COVER), 5/16-24 UNF	4	
13	07904320200014	NIPPLE, NPS2" X NPT2"	2	
14	1889350351	CHECK VALVE	1	
15	0105090840	BOLT (ENGINE), M8 X40	4	
16	1211390610	CASING COVER PACKING, OIL SHEET	1	
17	0481571950	O'RING (DRAIN COVER)	1	
18	0489402910	O'RING (CASING), 4 X 291 MM	1	
19	1889214010P002	BASE, SS400	1	
20	0481310550	O-RING (NIPPLE)	2	
21#	0482200180	O-RING" (MECHANICAL SEAL SLEEVE)	2	
22	18892140200014	ENGINE BASE, SS400	1	
23	0631211159	FLOODING CAP, PF1-1/2"	1	
24	0631211159	DRAIN CAP, PF1-1/2"	1	
25	0803442930	MECHANICAL SEAL	1	
26	0811345443	MECHANICAL SEAL SLEEVE, DIA. 25MM	1	
27	0852833020	ADJUST LINER DIA. 20 X 30 MM T0.3	1	
27-1	0852853020	ADJUST LINER DIA. 20 X 30 MM T0.5	1	
28#	0191190544	BOLT(IMPELLER), 5/16-24 UNF X 1-3/4.....	1	REPLACES P/N 0191190525
29	0131190820	SCREW (VOLUTE CASING) M8 X 20.....	2	REPLACES P/N 0141090820QP2
30	0141090825	SCREW (DRAIN COVER SET HANDLE) M8 X 25	4	
31	0131191270	CAP SCREW (CASING), M12 X 70	1	
32	0131191235	CAP SCREW (CASING), M12 X 35	4	
33	0105091035	BOLT (PUMP), M10 X 35	2	
34	0459220120	SEAL WASHER (CASING) M12	1	
35	0723302040	CUSHION RUBBER, 40 X 20 M10	4	
36	0181090820	BOLT SET W/SPRING WASHER M8 X 20 (SUCTION PLATE)	2	
37	0181090825	BOLT SET WITH SPRING WASHER M8 X 25	4	

### NOTICE

Item 21, O-ring, is included in impeller kit, item 6. When ordered as part of the kit, quantity of o-ring is one. Replacement of impeller requires two o-rings, so it is necessary to order one additional o-ring.

# PUMP ASSEMBLY

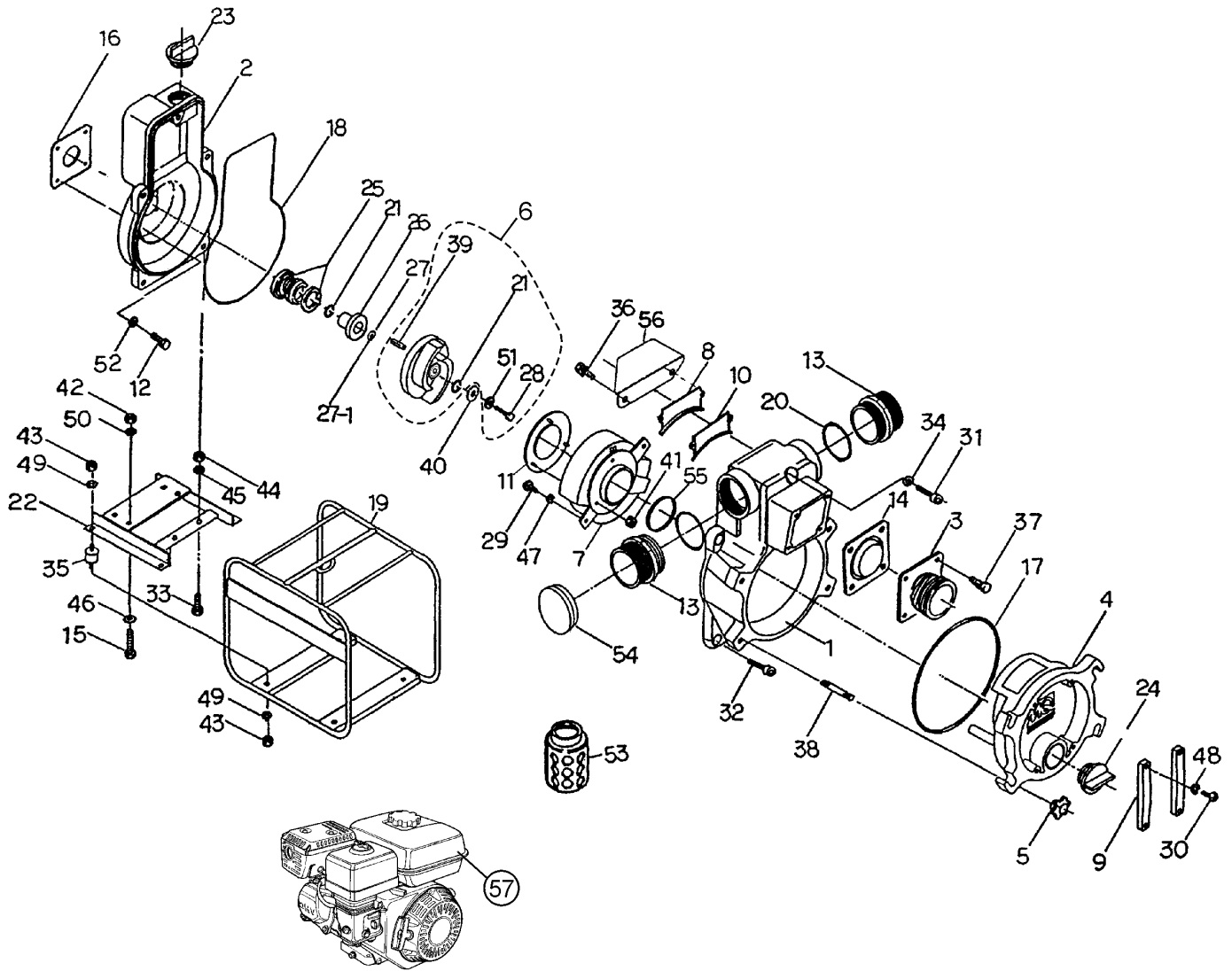



## PUMP ASSEMBLY

<u>NO.</u>	<u>PART NO.</u>	<u>PART NAME</u>	<u>QTY.</u>	<u>REMARKS</u>
38	0151191257	STUD BOLT, (DRAIN COVER HANDLE) M12 X 57 X15 X 22	4	
39#	0520030310	KEY, 4.7 X21 MM.....	1	REPLACES P/N 0520030413
40	43592012400011	IMPELLER WASHER, DIA. 35 X 9 MM T4.5	1	
41	0204490060	U-NUT, WEAR PLATE M6	3	
42	0205490080	NUT, ENGINE M8	4	
43	0205490100	NUT, CUSHION RUBBER M10	8	
44	0205490100	NUT, PUMP M10	2	
45	0451290100	SPRING WASHER, PUMP M10	2	
46	0401650080	WASHER, ENGINE M8	4	
47	0457290080	SPRING WASHER, (VOLUTE CASING)M8	2	
48	0451290080	SPRING WASHER, (DRAIN COVER SET M8	4	
49	0451290100	SPRING WASHER, (CUSHION RUBBER) M10	8	
50	0451290080	SPRING WASHER, (ENGINE) M8	4	
51#	0458220080	SPRING WASHER, (IMPELLER), M8 .....	1	REPLACES P/N 0451290080
52	0451290080	SPRING WASHER, (CASING COVER ) M8	4	
53	0742214050	STRAINER	1	
54	1889108050	CAP	1	
55	0481310700	O-RING	1	
56	1889250770	OVERFLOW SUPPRESSOR	1	
57	GX160K1QX2	ENGINE, HONDA 5.5 HP .....	1	S/N 2TH-3428 AND BELOW
57	GX160U1QX2	ENGINE, HONDA 5.5 HP .....	1	S/N 2TH-3429 TO 2TH-13438
57	GX160UT2QX2	ENGINE, HONDA 5.5 HP .....	1	S/N 2TH-13439 AND ABOVE

# ENGINE SERVICE PARTS

---

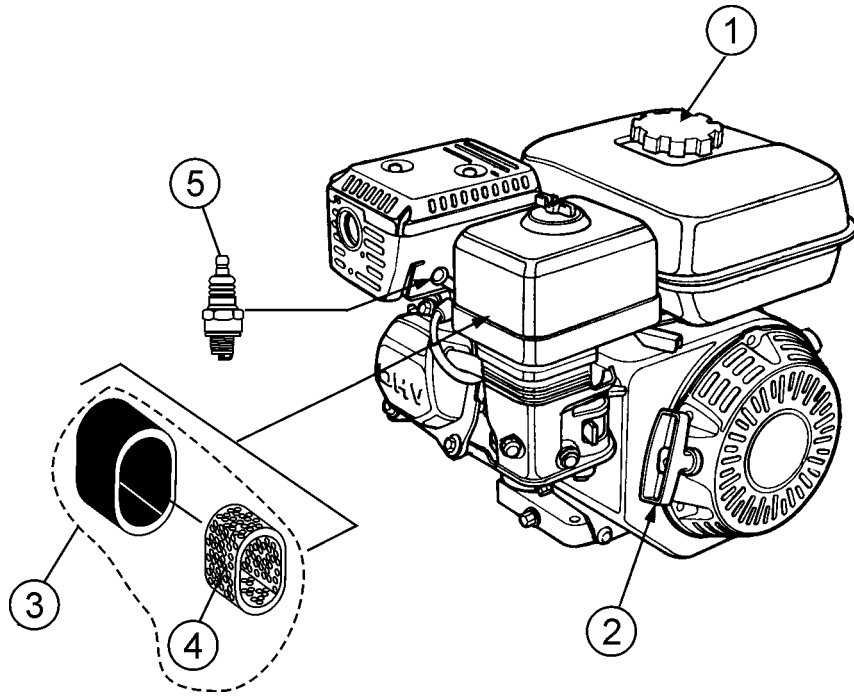

## ENGINE SERVICE PARTS

<u>NO.</u>	<u>PART NO.</u>	<u>PART NAME</u>	<u>QTY.</u>	<u>REMARKS</u>
1	17620ZH7023	CAP, WITH GASKET, FUEL FILLER.....	1.....	GX160K1QX2/GX160U1QX2
1	17620Z4M000	CAP, WITH GASKET, FUEL FILLER.....	1.....	GX160UT2QX2
2	28462ZE2W11	ROPE, RECOIL STARTER .....	1.....	GX160K1QX2/GX160U1QX2
2	28462ZH8003	ROPE, RECOIL STARTER .....	1.....	GX160UT2QX2
3	17210ZE2515	ELEMENT, AIR CLEANER .....	1.....	GX160K1QX2/GX160U1QX2 INCLUDES ITEM W/ #
3	17210ZE1517	ELEMENT, AIR CLEANER .....	1.....	GX160UT2QX2 INCLUDES ITEM W/ #
4#	17218ZE1507	FILTER, OUTER	1	
5	9807956846	SPARK PLUG	1	

# PARTS MANUAL

## HERE'S HOW TO GET HELP

PLEASE HAVE THE MODEL AND SERIAL  
NUMBER ON-HAND WHEN CALLING

### UNITED STATES

#### *Multiquip Inc.*

(310) 537- 3700  
6141 Katella Avenue Suite 200  
Cypress, CA 90630  
E-MAIL: [mq@multiquip.com](mailto:mq@multiquip.com)  
WEBSITE: [www.multiquip.com](http://www.multiquip.com)

### CANADA

#### *Multiquip*

(450) 625-2244  
4110 Industriel Boul.  
Laval, Quebec, Canada H7L 6V3  
E-MAIL: [infocanada@multiquip.com](mailto:infocanada@multiquip.com)

### UNITED KINGDOM

#### *Multiquip (UK) Limited Head Office*

0161 339 2223  
Unit 2, Northpoint Industrial Estate,  
Globe Lane,  
Dukinfield, Cheshire SK16 4UJ  
E-MAIL: [sales@multiquip.co.uk](mailto:sales@multiquip.co.uk)

© COPYRIGHT 2020, MULTIQUIP INC.

Multiquip Inc, the MQ logo are registered trademarks of Multiquip Inc. and may not be used, reproduced, or altered without written permission. All other trademarks are the property of their respective owners and used with permission.

This manual MUST accompany the equipment at all times. This manual is considered a permanent part of the equipment and should remain with the unit if resold.

The information and specifications included in this publication were in effect at the time of approval for printing. Illustrations, descriptions, references and technical data contained in this manual are for guidance only and may not be considered as binding. Multiquip Inc. reserves the right to discontinue or change specifications, design or the information published in this publication at any time without notice and without incurring any obligations.

Your Local Dealer is:

