

# BlueDiamond®

condensate removal pumps

## MegaBlue®

The MegaBlue has a slimline, lightweight design and is whisper quiet, it also has the performance to overcome installation difficulties and uses the BlueDiamond revolutionary patented principle, making it inherently reliable. With the MegaBlue there's no cost penalty up front but big savings on installation and in service beyond.



UL US LISTED  
Plenum Rated

3 year warranty

### Performance

23dba

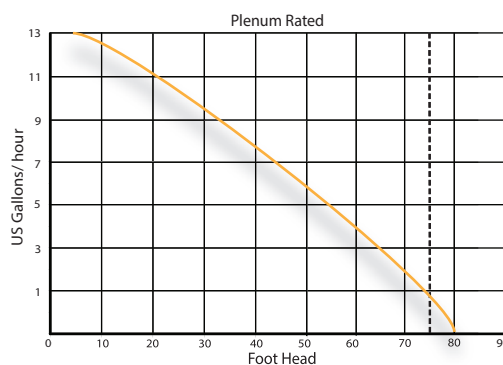

Max flow	Max head	Max suction lift
13.2 g/hr	66.5 ft	23 ft

**\*Dual Voltage 110V-230V 50/60Hz**



### Sensing Options

**MegaBlue® pump available with one of the following options:**

Reservoir sensor	Temperature sensor	DrainStik®
X87-835	X87-833	X87-834
		

### Dimensions (")

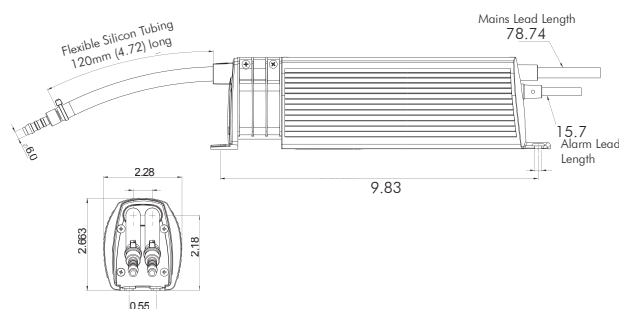

### BlueDiamond® technology

Not only is the MegaBlue® backed by a three year warranty, it also uses the BlueDiamond® patented rotary diaphragm technology. The condensate is drawn into the pump by vacuum and mechanically driven within a re-inforced elastomer diaphragm to the outlet under pressure. This system even tolerates suspended solids and light slurries whilst happily running dry.

### Installation Options

The MegaBlue® can be mounted in any orientation up to 23ft away from the air conditioning unit.

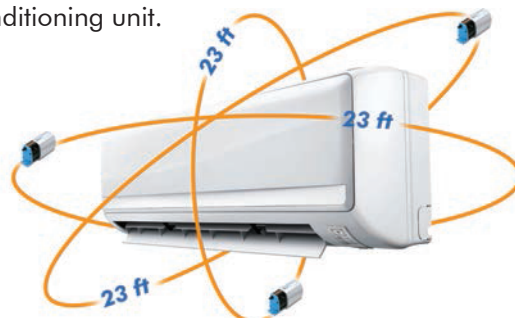

**Blue Diamond**  
Pumps Inc

+1 770 831 1122

info@bluediamondpumps.com

www.bluediamondpumps.com