

INSTALLATION INSTRUCTIONS

KEH067A41E(A), KEH063A4E(A), FTDBHMS, FTDBHML

SAFETY CONSIDERATIONS

Read these **Safety Considerations** carefully before installing the drain pan heater. After completing the installation, check if the unit operates properly during the start-up operation.

Meaning of **DANGER**, **WARNING**, and **CAUTION** symbols



Indicates an imminently hazardous situation which, if not avoided, will result in death or serious injury.



Indicates a potentially hazardous situation which, if not avoided, could result in death or serious injury.



Indicates a potentially hazardous situation which, if not avoided, may result in minor or moderate injury. It may also be used to alert against unsafe practices.

- Inform users that they should store this installation manual for future reference.
- After completing the installation, make sure that the unit operates properly during the startup operation.
- All phases of the field-installation, including, but not limited to, electrical, piping, and safety, must be done in accordance with manufacturer's instructions and must comply with national, state, provincial, and local codes.
- This product is a heater designed to melt snow that is blown into the product from the outside to prevent the drain pan of the outdoor unit from freezing.
- Install the product with a snow-break hood on a high stand if this product is used in heavy snow areas.



WARNING

ONLY PERSONNEL THAT HAVE BEEN TRAINED TO INSTALL, ADJUST, SERVICE OR REPAIR (HEREINAFTER, "SERVICE") THE EQUIPMENT SPECIFIED IN THIS MANUAL SHOULD SERVICE THE EQUIPMENT. THE MANUFACTURER WILL NOT BE RESPONSIBLE FOR ANY INJURY OR PROPERTY DAMAGE ARISING FROM IMPROPER SERVICE OR SERVICE PROCEDURES. IF YOU SERVICE THIS UNIT, YOU ASSUME RESPONSIBILITY FOR ANY INJURY OR PROPERTY DAMAGE WHICH MAY RESULT. IN ADDITION, IN JURISDICTIONS THAT REQUIRE ONE OR MORE LICENSES TO SERVICE THE EQUIPMENT SPECIFIED IN THIS MANUAL, ONLY LICENSED PERSONNEL SHOULD SERVICE THE EQUIPMENT. IMPROPER INSTALLATION, ADJUSTMENT, SERVICING OR REPAIR OF THE EQUIPMENT SPECIFIED IN THIS MANUAL, OR ATTEMPTING TO INSTALL, ADJUST, SERVICE OR REPAIR THE EQUIPMENT SPECIFIED IN THIS MANUAL WITHOUT PROPER TRAINING MAY RESULT IN PRODUCT DAMAGE, PROPERTY DAMAGE, PERSONAL INJURY OR DEATH.



DANGER

DO NOT TOUCH THE HEATER UNIT WITHOUT WEARING GLOVES. THE TEMPERATURE OF THE HEATER UNIT WILL BECOME HIGH WHEN THE HEATER IS TURNED ON. TOUCHING THE HEATER UNIT WITH BARE HANDS WILL RESULT IN BURNS OR INJURY.



WARNING

- WEAR PROTECTIVE GLOVES AT THE TIME OF INSTALLATION. TOUCHING THE SUCTION MOUTH OR ALUMINUM FIN OF THE OUTDOOR UNIT MAY RESULT IN INJURY.
- DO NOT INSTALL THE PRODUCT IN PLACES WHERE THERE IS DANGER OF EXPOSURE TO INFLAMMABLE GAS LEAKAGE. IF THE GAS LEAKS AND BUILDS UP AROUND THE UNIT, IT MAY CATCH FIRE.
- DO NOT GRAB THE TOP PLATE OF THE OUTDOOR UNIT CARELESSLY WHEN REMOVING THE TOP PLATE. THE SHARP EDGE OF THE TOP PLATE MAY CAUSE INJURY.
- DO NOT INSTALL THE OUTDOOR UNIT IN PLACES WHERE SMALL ANIMALS MAY NEST IN THE OUTDOOR UNIT. IF SMALL ANIMALS INTRUDE AND TOUCH THE INTERNAL PARTS OF THE OUTDOOR UNIT, THE OUTDOOR UNIT MAY MALFUNCTION, GENERATE SMOKE, OR IGNITE. ADVISE THE USER TO KEEP THE PLACE CLEAN.
- DO NOT TOUCH THE HEATER UNIT WITH BARE HANDS. THE TEMPERATURE OF THE HEATER UNIT WILL BECOME HIGH WHEN THE HEATER IS TURNED ON. TOUCHING THE HEATER UNIT WITH BARE HANDS MAY RESULT IN BURNS OR INJURY.

Our continuing commitment to quality products may mean a change in specifications without notice.

© 2021 **DAIKIN MANUFACTURING COMPANY, L.P.**

19001 Kermier Rd. Waller, Tx 77484

www.daikincomfort.com











WARNING

- **REQUEST THE DEALER OR AN AUTHORIZED TECHNICIAN TO INSTALL THE PRODUCT.**
IMPROPER INSTALLATION OF THE PRODUCT COULD RESULT IN WATER LEAKAGE, AN ELECTRIC SHOCK, OR FIRE.
- **THE PRODUCT MUST BE INSTALLED ACCORDING TO THE INSTRUCTIONS GIVEN IN THIS MANUAL.**
THE INCOMPLETE INSTALLATION OF THE PRODUCT COULD RESULT IN WATER LEAKAGE, AN ELECTRIC SHOCK, OR FIRE.
- **USE THE SUPPLIED OR SPECIFIED INSTALLATION PARTS.**
USE OF OTHER PARTS COULD RESULT IN THE UNIT BECOMING LOOSE AND FALLING, WATER LEAKAGE, ELECTRIC SHOCK, OR FIRE.
- **TURN OFF THE POWER SUPPLY AT THE TIME OF INSTALLATION.**
TOUCHING ANY ELECTRICAL PARTS WITH THE POWER SUPPLY TURNED ON COULD RESULT IN ELECTRIC SHOCK.
- **USE SPECIFIED WIRES. CONNECT AND FIX THE WIRES SO THAT THE WIRES WILL NOT PUT IMPROPER FORCE ON THE TERMINAL JUNCTIONS.**
WIRES CONNECTED OR FIXED IMPROPERLY COULD RESULT IN TERMINAL OVERHEATING, AN ELECTRIC SHOCK, OR FIRE.
- **WHEN WIRING AND CONNECTING THE INDOOR AND OUTDOOR UNITS, CAREFULLY ARRANGE THE WIRING SO THAT THEY WILL NOT PUT IMPROPER FORCE ON THE STRUCTURES.**
INSTALL COVERS OVER THE WIRES. INCOMPLETE COVER INSTALLATION COULD RESULT IN TERMINAL OVERHEATING, AN ELECTRIC SHOCK, OR FIRE.

ACCESSORIES

Read these **Safety Considerations** carefully before installing the drain pan heater. After completing the installation, check if the unit operates properly during the start-up operation.

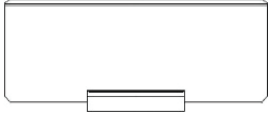
		KEH067A41E(A) FTDBHMS	KEH063A4E FTDBHML	KEH063A4EA
(A) Drain Pan Heater		1	1	1
(B) M4 piercing screw		3	6	6
(C) Binding band		1	1	1
(D) Sealing Material		1	2	2
(E) Installation Manual (multi-language)		1	1	1
(F) Electric Wiring Diagram Label		1	1	1
(G) Information Label		1	1	1
(H) Alternate Mounting Plate		0	0	3

TOOLS REQUIRED

- Electric Drill
- $\phi 1/8$ inch ($\phi 3.2$ mm) drill
- Phillips Screwdriver
- Nippers

INSTALLATION PROCEDURE



WARNING

BE SURE TO CHECK THAT THE POWER SUPPLY OF THE PRODUCT IS TURNED OFF.

Some stages in the installation procedure differ by model of the outdoor unit. Refer to the instructions for the relevant model.

TYPE A MODELS: RX09/12NMVJU, RX09/12AXVJU, RXN09/12, RXL09/12

TYPE B MODELS: RX18/24NMVJU, RXN18/24, RXL15

TYPE C MODELS: 2/3/4MXS, 2/3MXL

TYPE D MODELS: RX18/24AXVJU

TYPE E MODELS: RX09/12RMVJU9A, RXL09/12QMVJU(9)A

1. REMOVE EACH COMPONENT OF THE OUTDOOR UNIT.

1. Remove the top plate.
2. Affix the ⑥ electric wiring diagram label where there is enough space available on the back of the top plate.
3. Remove the screws from the protective wire mesh if one is fitted. (2 screws)
(For type B and C models only)
4. Remove the front plate.
5. Remove the anti-drip cover.
(For type B and C models only)
6. Affix the ⑦ information label near the manufacture's label.
 - The appearance of the outdoor unit and the number of screws may differ from some models.
 - Screw types for each component are indicated as below.

No Icon: Hexagon tapping screw

△ : Truss head tapping screw

FOR TYPE A AND D MODELS

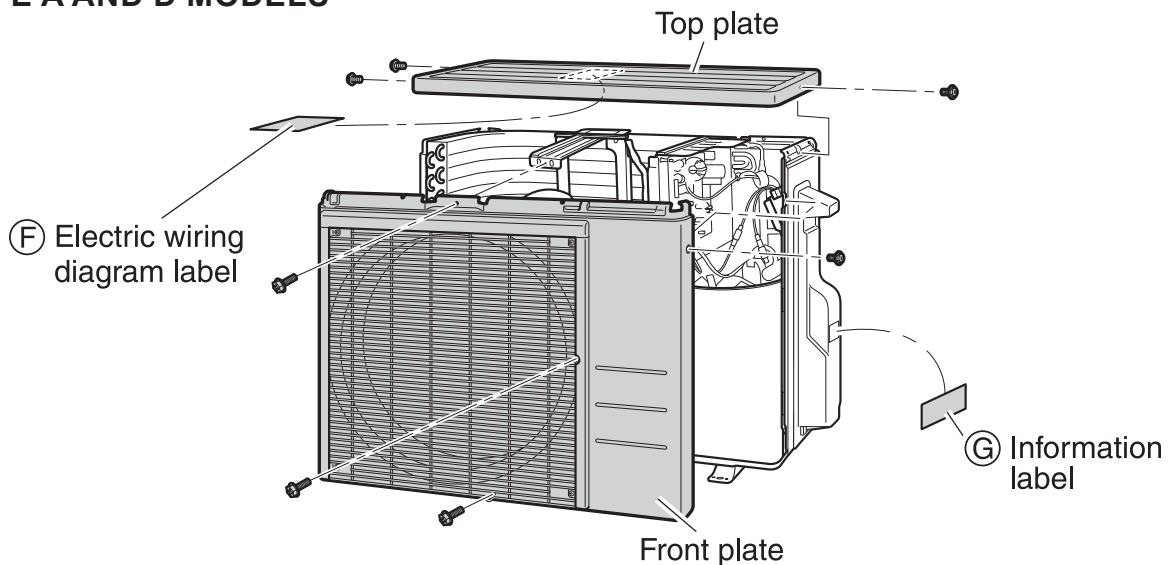

FOR TYPE B AND C MODELS

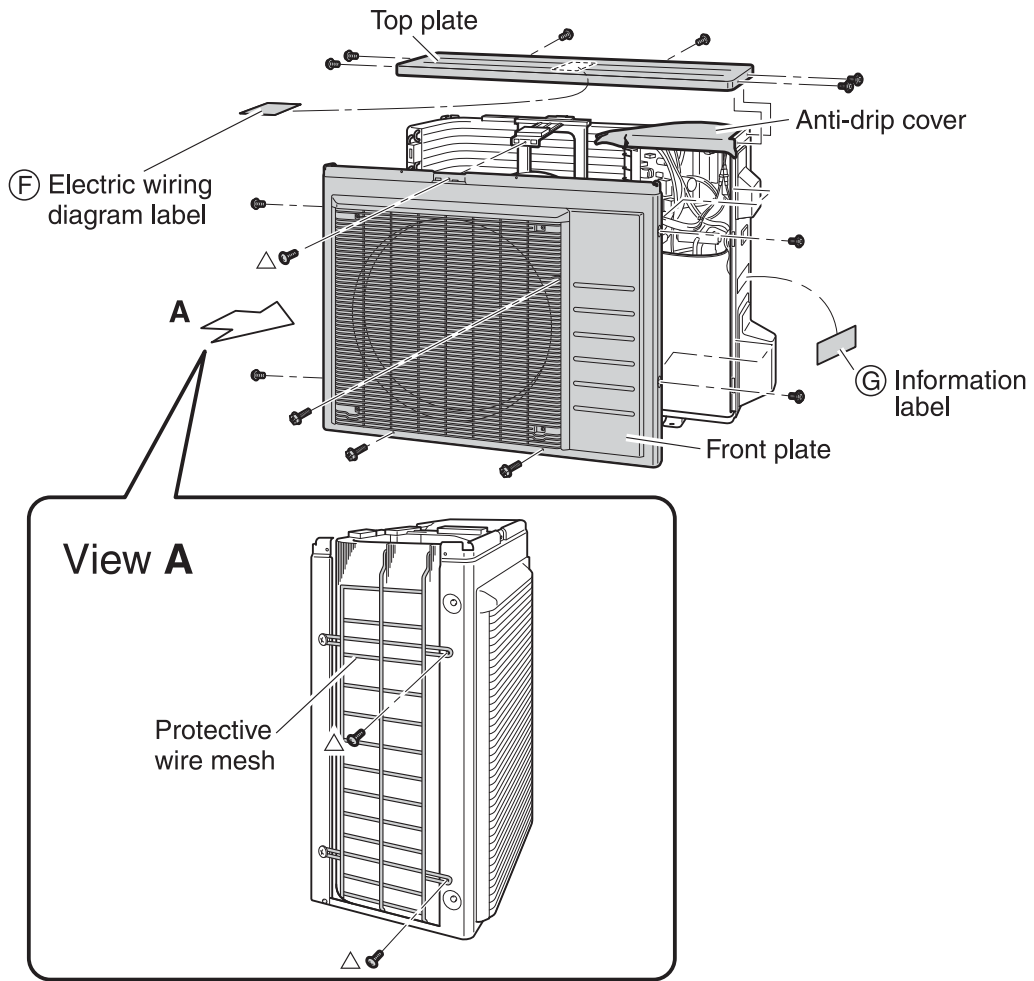

FOR TYPE E MODELS

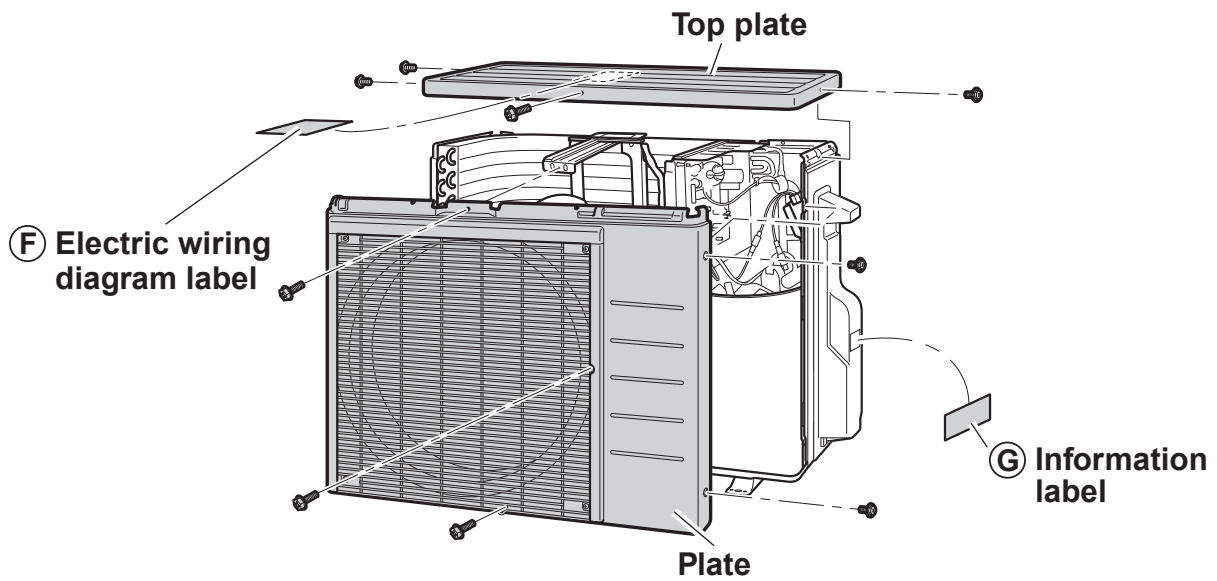

2. REMOVE THE FAN MOTOR BASE.

1. Remove the fixing screws at the lower section of the fan motor base. (2 screws)
2. Remove the fan motor base together with the propeller fan and ensure that stress is not placed on the propeller fan when placing them aside.
 - Do not remove the fan motor harness.
 - Ensure that the fan motor harness does not come into contact with the edges of the heat exchanger or other components.

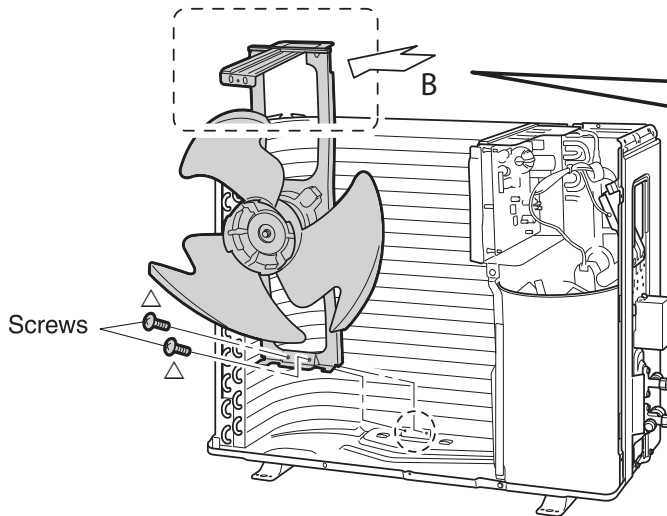

View B

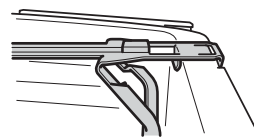

The lugs of the fan motor base are hooked on the heat exchanger.

Appearance of the outdoor unit may differ from some models.

△: Truss head tapping screw

3. INSTALL THE DRAIN PAN HEATER.



CAUTION

WHEN DRILLING A HOLE, BE CAREFUL NOT TO DAMAGE THE SOUNDPROOFING MATERIAL AND OTHER COMPONENTS ON THE BACK SIDE.

1. For type D models, exchange the pre-mounted mounting plates for 2 of the (H) alternate mounting plates as indicated below:

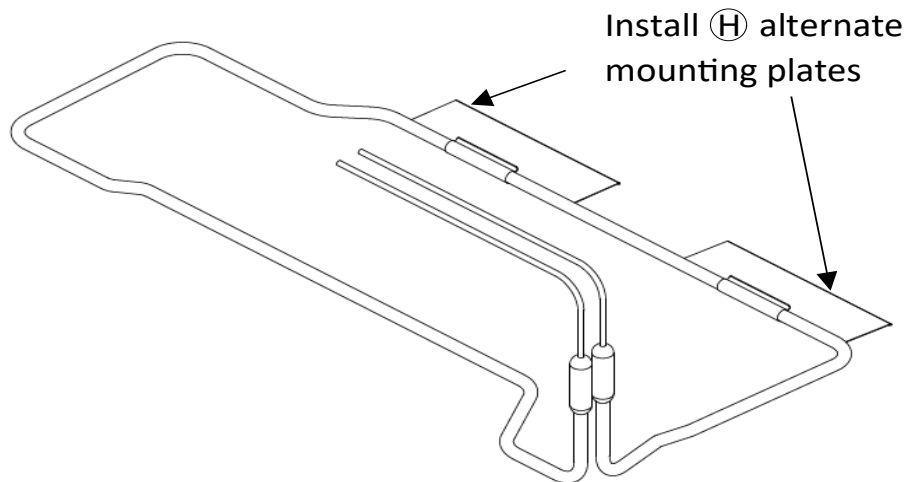
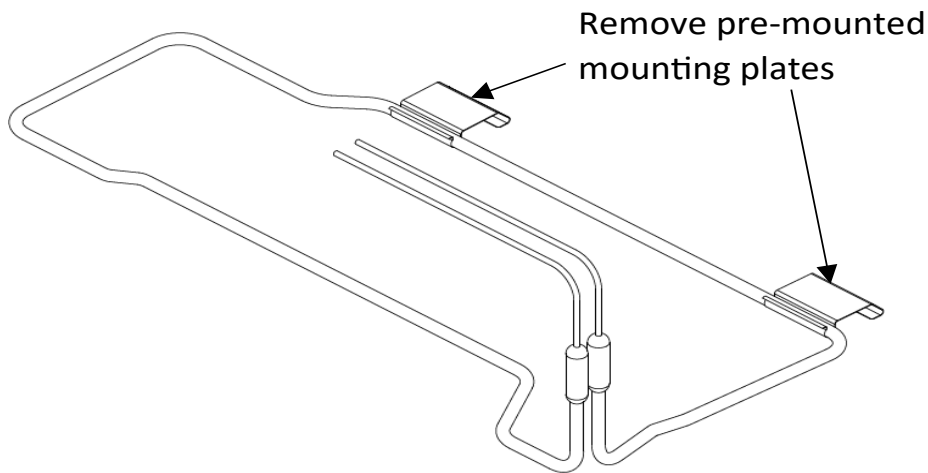

2. Remove 1 screw from the bottom frame (and 1 screw from the left frame for type D models) so that the plates of the (A) drain pan heater can be inserted under the heat exchanger with ease.
3. Lift up the heat exchanger, and insert the plates of the (A) drain pan heater under the heat exchanger.
 - The ground plate of the (A) drain pan heater should be installed so that, in type A models, it firmly adheres to the bottom frame and, in type B and C models, it firmly adheres to the partition plate.
 - Install the (A) drain pan heater in a position where it does not come into contact with the fan motor base.
4. If there are no holes, drill $\phi 1/8$ inch ($\phi 3.2$ mm) holes in the bottom frame or the partition plate (model type dependent) to fix the (A) drain pan heater.
 - Place the actual components to ensure positioning is correct before drilling holes.
 - The holes can be made with the included piercing-screw as well.
5. Fix the (A) drain pan heater with the (B) piercing screws.
6. Reattach the screw that was removed from the bottom frame (as well as the screw that was removed from the left frame for type D models).

FOR TYPE A AND E MODELS

Location and number of holes
Bottom frame: 2

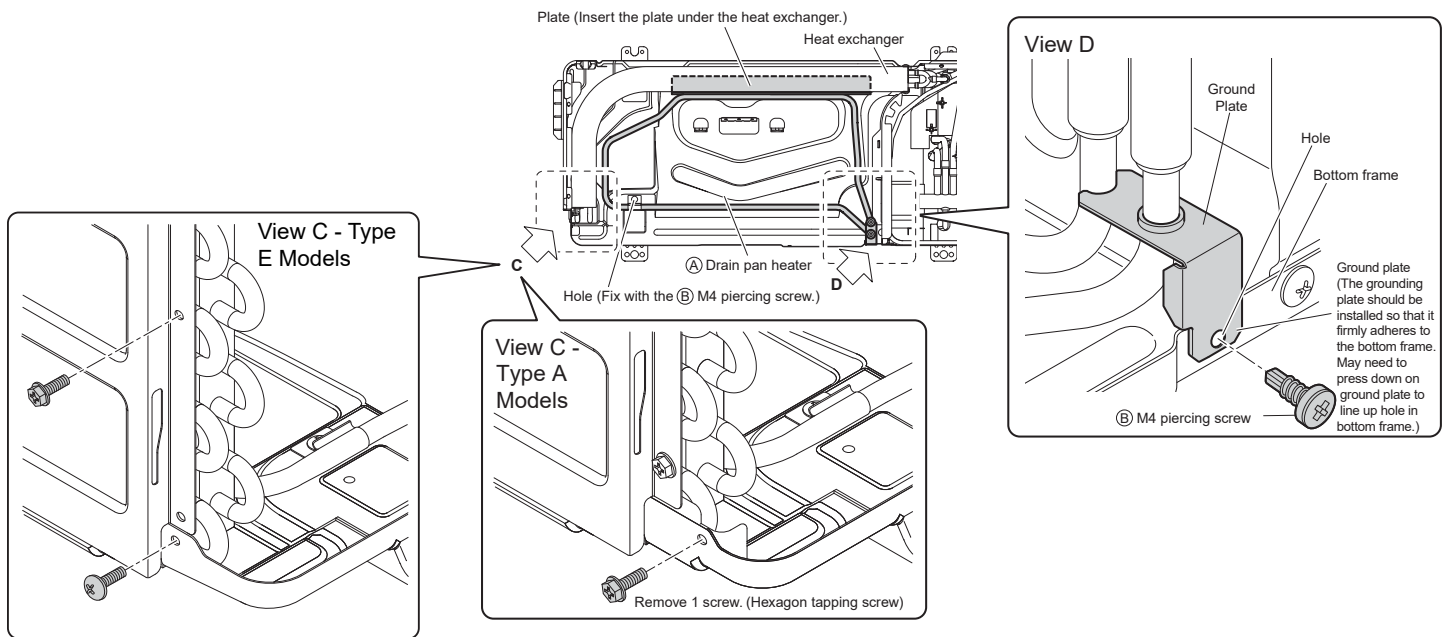

FOR TYPE B, C, AND D MODELS

Location and number of holes
Bottom frame: 1
Partition plate: 2

Plates (Insert the plates under the heat exchanger.)

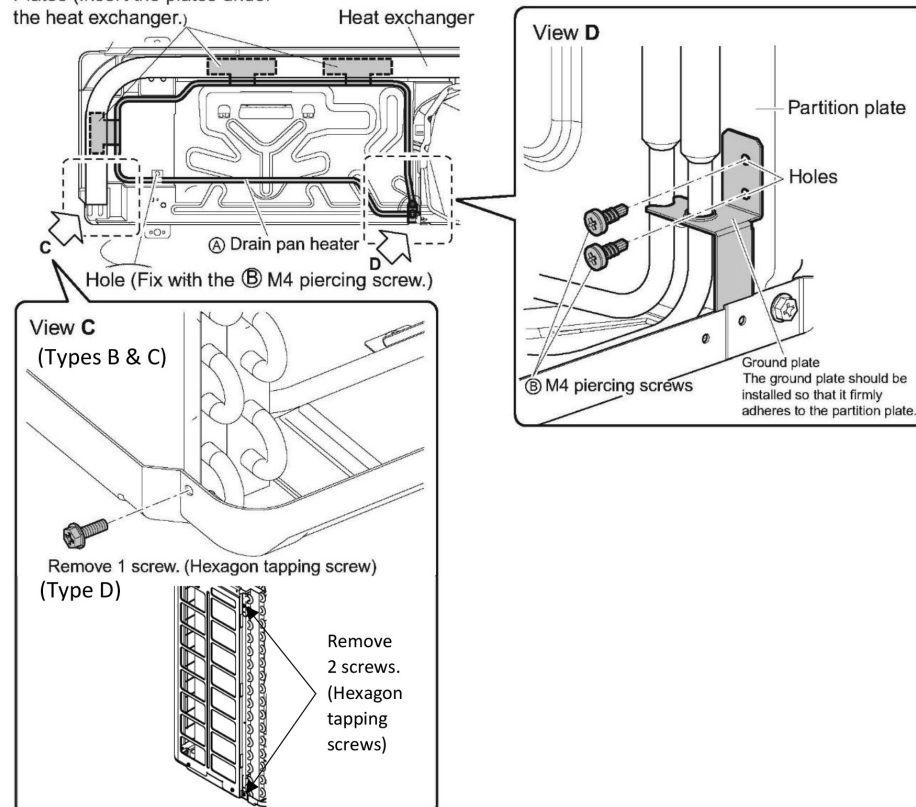

4. ROUTE THE HARNESES.



CAUTION

WHEN DRILLING A HOLE, BE CAREFUL NOT TO DAMAGE THE SOUNDPROOFING MATERIAL AND OTHER COMPONENTS ON THE BACK SIDE.

FOR TYPE A AND E MODELS

1. If there is no hole, drill a $\phi 1/8$ inch ($\phi 3.2\text{mm}$) hole in the partition plate. (1 location)
2. Fix in place the binding band attached to the (A) drain pan heater harness by screwing the (B) M4 piercing screw into the hole. (1 location)
3. Install the fan motor base.
 - Be careful not to confuse screw types. Refer to “**Installation Procedure (2)**”.
4. Place the (A) drain pan heater harness on top of the fan motor harness, and fix it in place with the (D) sealing material.

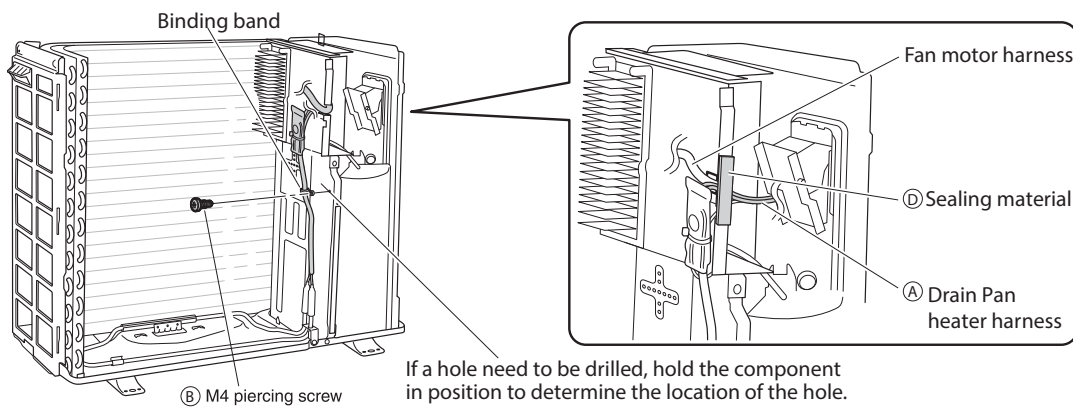

FOR TYPE B, C, AND D MODELS

1. If there is no hole, drill $\phi 1/8$ inch ($\phi 3.2\text{mm}$) holes in the partition plate. (3 locations)
2. Fix the (A) drain pan heater harness in place by screwing the (B) M4 piercing screws into the holes. (3 locations)
3. Install the fan motor base.
 - Be careful not to confuse screw types. Refer to “**Installation Procedure (2)**”.
4. Trim the electrical wiring box with nippers at the locations shown in the figures, then cover the trimmed edges with the (D) sealing material.
5. Insert the (A) drain pan heater harness into the space that was trimmed, and fix it in place using the (D) sealing material.

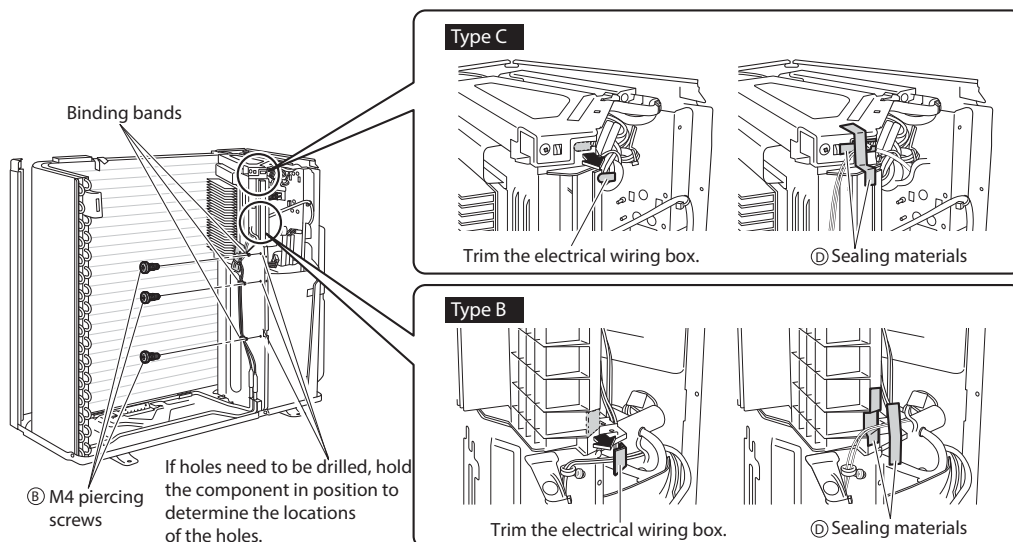

FOR TYPE D MODELS

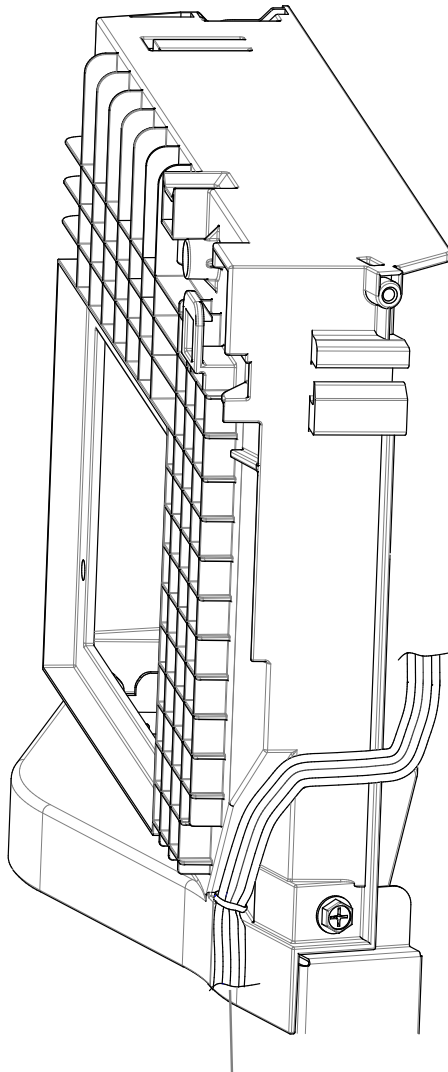

Route wire as shown

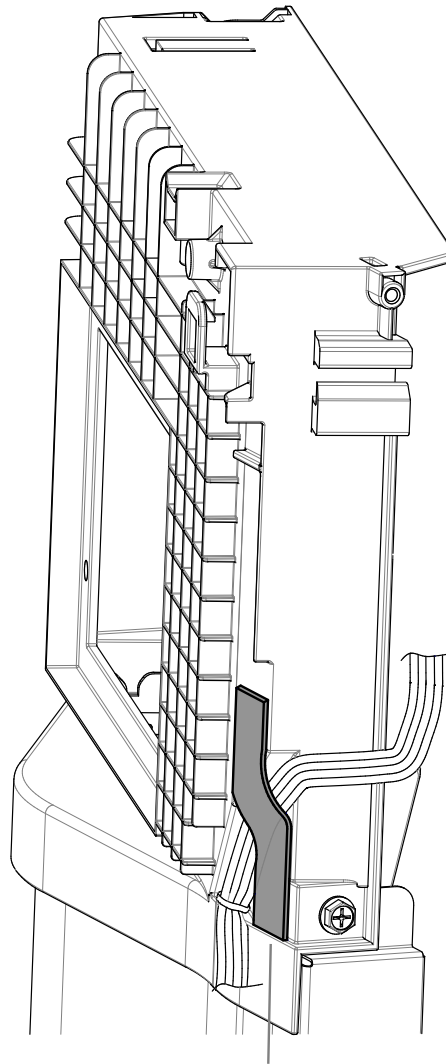

Sealing material

5. CONNECT THE TERMINALS OF THE DRAIN PAN HEATER TO THE TERMINAL BLOCK OF THE OUTDOOR UNIT.

1. Connect the thermostat-side terminal (black harness) to the leftmost terminal and the heater-side terminal (white harness) to the second leftmost terminal.
 - For type C models, connect to the last terminal block of the terminal blocks in use.
2. Bundle the drain pan heater harness so that there is no slack, and secure it with the binding band. (1 location)
 - For type C models, connect to the last terminal block of the terminal blocks in use.

FOR TYPE A AND E MODELS

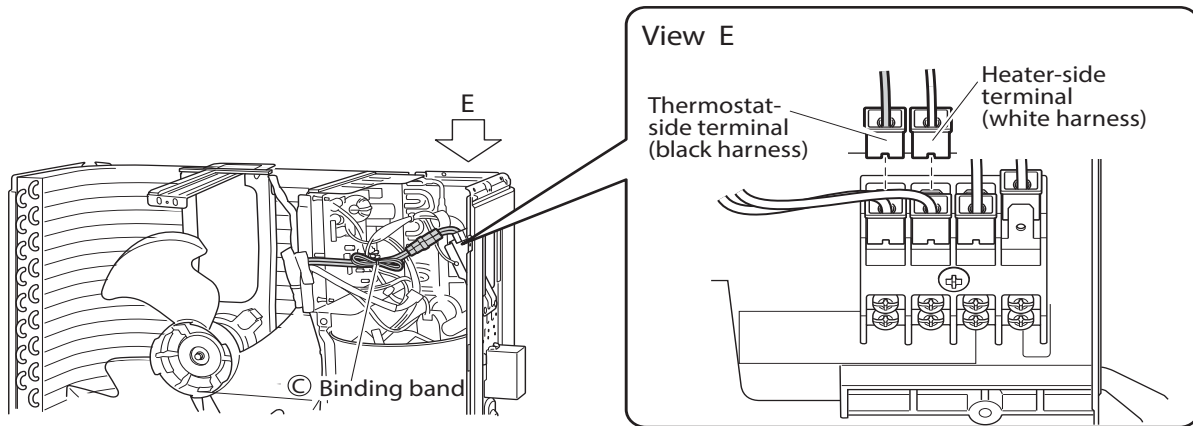

FOR TYPE B AND D MODELS

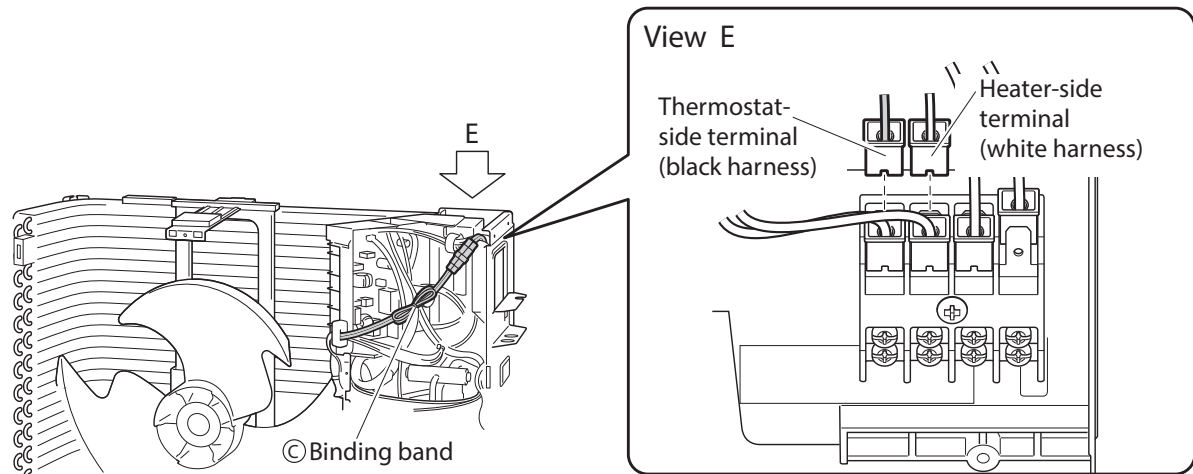

FOR TYPE C MODELS

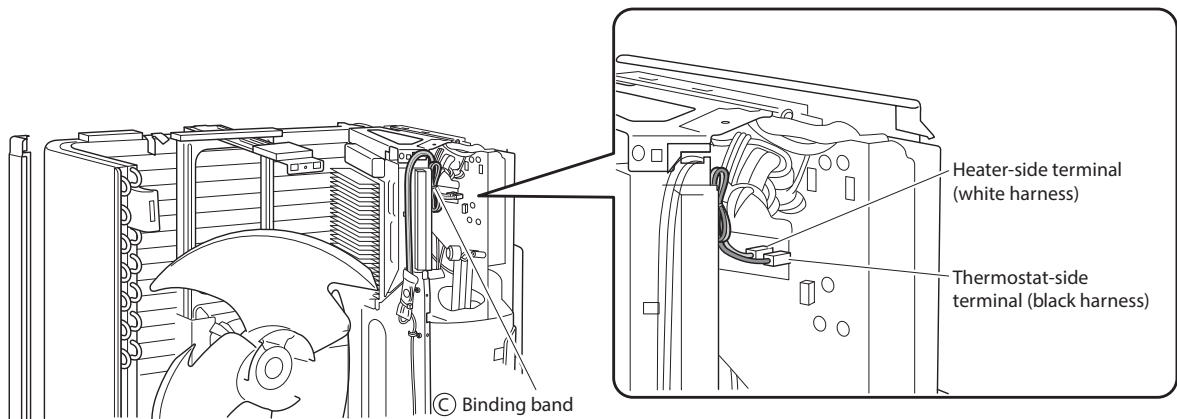

6. INSTALL EACH COMPONENT TO THE ORIGINAL POSITION.

- Be careful not to confuse screw types. Refer to "Installation Procedure (1)".

1. Install the front plate.
2. Install the anti-drip cover.
(For type B and C models only)
3. Install the top plate.

THIS PAGE INTENTIONALLY LEFT BLANK.

CUSTOMER FEEDBACK

Daikin is very interested in all product comments.

Please fill out the feedback form on the following link:

<https://daikincomfort.com/contact-us>

You can also scan the QR code on the right to be directed to the feedback page.



Our continuing commitment to quality products may mean a change in specifications without notice.

© 2021 **DAIKIN MANUFACTURING COMPANY, L.P.**

19001 Kermier Rd. Waller, Tx 77484

www.daikincomfort.com