



# COLLECT<sub>AN</sub>DRAIN<sup>®</sup>

## Model 5100ALBV

100 Quaker Lane, Malvern, PA 19355 • Phone: 610-240-4900 • Fax: 610-240-4906 • www.agfmanufacturing.com

The **COLLECT<sub>AN</sub>DRAIN<sup>®</sup>** Family of products are auxiliary drains (low-point drains, drum drips, condensation collection assemblies) available in several configurations to meet and exceed NFPA 13 and NFPA 25 requirements addressing drainage in dry and pre-action sprinkler systems.

### Model 5100ALBV COLLECT<sub>AN</sub>DRAIN<sup>®</sup>

The COLLECT<sub>AN</sub>DRAIN<sup>®</sup> Model 5100ALBV detects the presence of water in dry pipe sprinkler system auxiliary drains and small volume, trapped pipe sections. The Model 5100ALBV is designed to detect even the smallest amount of water in the auxiliary drain or small volume, trapped pipe section so they can be maintained before the water becomes a problem, especially in cold climates.

The Model 5100ALBV includes a high-quality ball valve with a chrome-plated brass ball and water detector with audible and visual alerts that flash and sound when water is detected in the auxiliary drain or the small volume, trapped pipe section.

When the Model 5100ALBV detects even the smallest amount of water it flashes a visual alert and sounds an audible alert to notify you that maintenance is needed. For remote notification it can be wired to the fire panel or BMS. The Model 5100ALBV can be powered several different ways: with a 9V battery, 12-24 VDC, or optional 110V plug-in.



Model 5100ALBV

### Model 5100ALBV Features

- 1" MIPT x FIPT high-quality quarter turn valve with chrome plated brass ball
- Visual and audible alarms
- Remote fire panel and BMS notification capabilities
- Customer enabled Temperature Sensor function
- Ideal for retro-fitting into systems (see reverse side)

### Model 5100ALBV Options

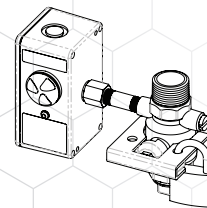

Locking Kit  
(Lock not included)

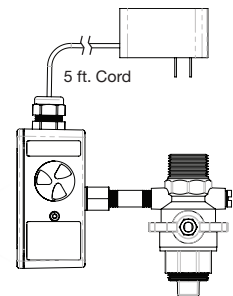

110V Plug-In

### Frequently Asked Questions

**Q: How long will the 9V battery last?**

A: Up to two years using standard alkaline battery (AGF recommends replacing the battery during annual system testing). Unit will chirp when the battery needs to be replaced.

**Q: How loud is the alarm?**

A: 100 dB(A) at 24 inches.

**Q: How long will the unit alert when it is powered by a 9V battery?**

A: 72 continuous hours with new battery.

**Q: When enabled, at what temperature does the temperature sensor function?**

A: When the ambient temperature falls below 45°F and there is water present the Model 5100ALBV will activate the audible and visual alerts.

**Reliability, Versatility, Code Compatibility**

## Model 5100ALBV Retro-fitting

The Model 5100ALBV can be easily retro-fitted onto existing auxiliary drains. On auxiliary drains with no special limitations remove the bottom drain valve from the auxiliary drain and replace with the Model 5100ALBV. If the auxiliary drain has space constraints you must separate the valve from the enclosure and install each component separately. First, unthread the nipple at the end closest to the valve (DO NOT unthread the nipple at the side closest to the enclosure) and install the valve, then, thread the enclosure back onto the valve.

## Model 5100ALBV Dimensions

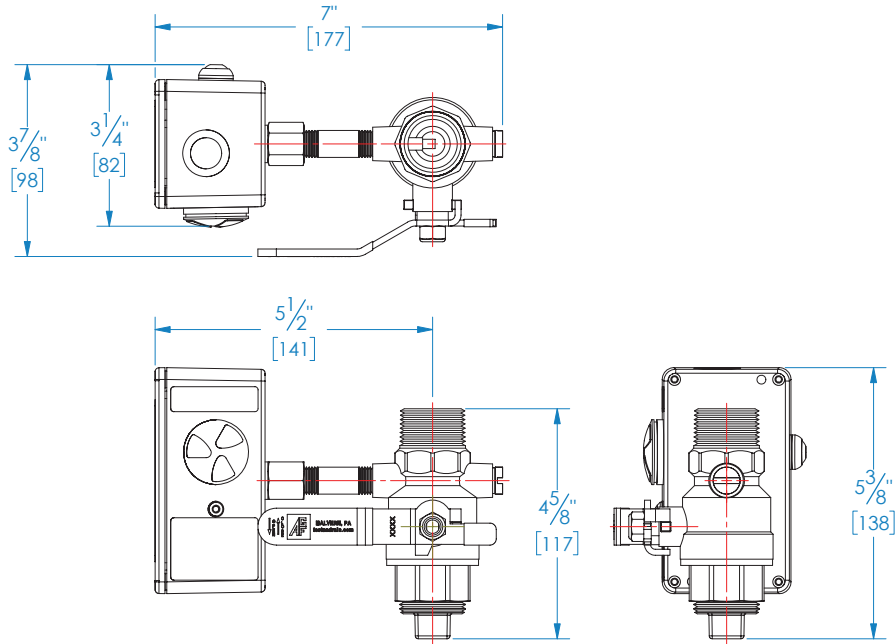

## Meet the COLLECT<sub>and</sub>DRAIN<sup>®</sup> Family

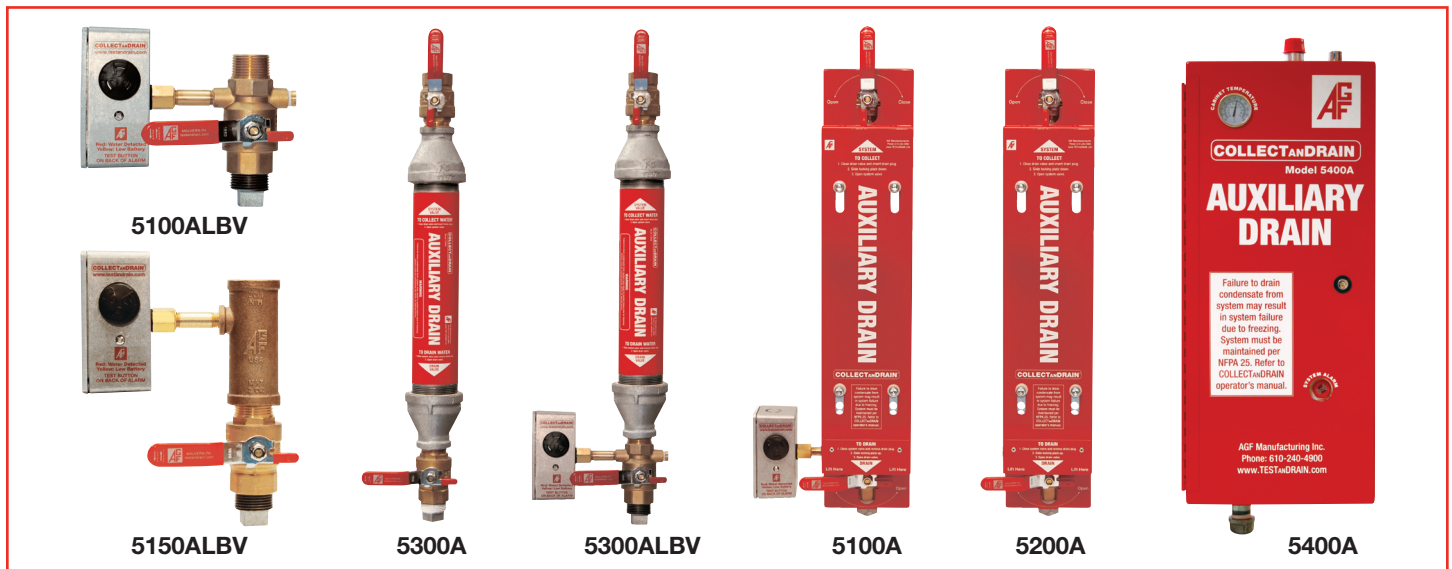

Patent Pending



**AGF Manufacturing Inc.**  
 100 Quaker Lane, Malvern, PA 19355  
 Phone: 610-240-4900  
 Fax: 610-240-4906  
[www.agfmanufacturing.com](http://www.agfmanufacturing.com)

Job Name: \_\_\_\_\_

Architect: \_\_\_\_\_

Engineer: \_\_\_\_\_

Contractor: \_\_\_\_\_