

5' Curb Inlet

Specifications:

1. CONCRETE: 5,000 PSI
2. REINFORCING: per ASTM A-615 or A-185
3. WEIGHT:

BASE 6,300 LBS
 EXTENSION 1,350 LBS
 TOP 3,600 LBS
 11,250 LBS Total

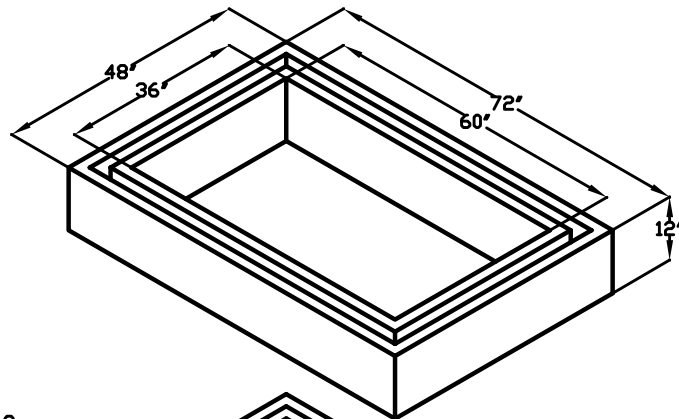
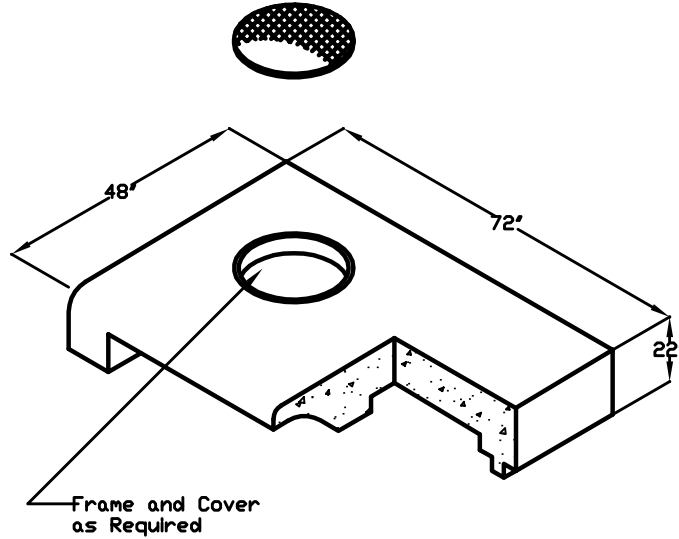

#3 Rebar, 12' O.C.
 Left Exposed for
 Gutter Tie-In

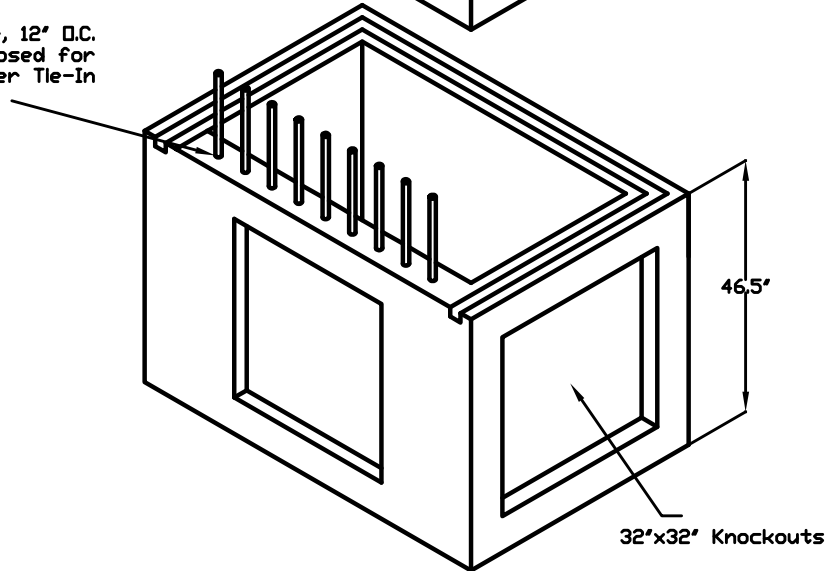

The Turner Company		11049 Highway 287 Rhone, Tx 76078 (817) 638-9033
Product: 5' Curb Inlet		
Concrete: 5,000 PSI MIN. - 28 DAY STRENGTH		
Reinforcement: MEETS OR EXCEEDS ASTM A-615 or A-185		
Size:	Date:	DWG No.
Weight:		