

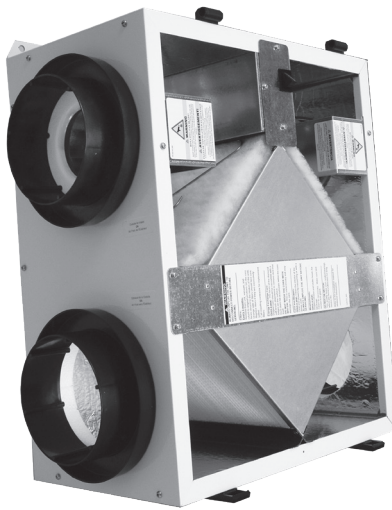

INSTALLATION, OPERATION & MAINTENANCE MANUAL ENERGY RECOVERY VENTILATOR

GR90
EV90
EV90P



- MODEL: EV90
- ◆ PAINTED CASE
 - ◆ LOW VOLTAGE CONTROLS
 - ◆ LINE CORD

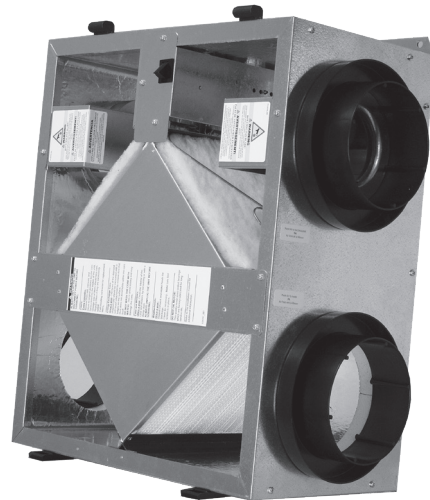

- MODEL: GR90
- ◆ GALVANIZED CASE
 - ◆ LINE VOLTAGE
 - ◆ NO LINE CORD

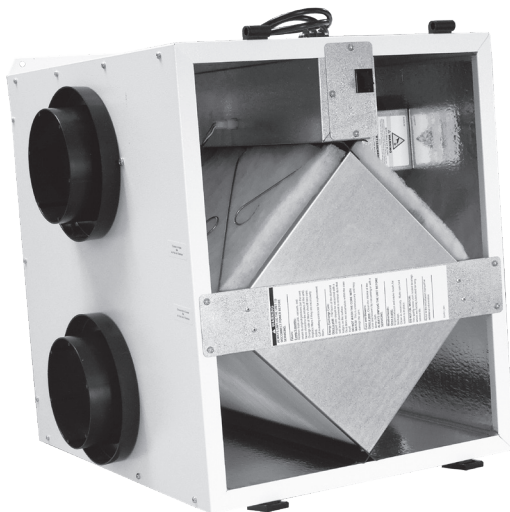

- MODEL: EV90P
- ◆ HIGH PERFORMANCE UNIT
 - ◆ PAINTED CASE
 - ◆ LOW VOLTAGE CONTROLS
 - ◆ LINE CORD



TABLE OF CONTENTS

Product info	2-6
Installation	7-13
Operation & Start-up	13-15
Maintenance	18-19

GR90, EV90, AND EV90P INFO**⚠ WARNING**

There is no known safe level of cigarette smoke. Any ventilation system may provide noticeable improvement in spaces where cigarettes are smoked, but it cannot be expected to protect against the severe long-term health hazards of exposure to cigarette smoke.

ABOUT RENEWAIRE

For over 30 years, RenewAire has been a pioneer in improving people's health, cognitive function, productivity and wellbeing by enhancing indoor air quality (IAQ) in homes and buildings of every type. This is done energy-efficiently, cost-effectively and sustainably via our fifth-generation, static-plate, enthalpy-core Energy Recovery Ventilators (ERVs) and Dedicated Outdoor Air Systems (DOAS) that reuse otherwise-wasted energy to condition incoming outdoor air. This process optimizes energy efficiency, lowers capital costs by reducing HVAC loads and decreases operational expenses by downsizing equipment, resulting in major energy and cost savings. RenewAire technologies also enjoy the industry's best warranty with the fewest claims due to tremendous reliability, flexibility and ease of use.

RenewAire was the first innovator with static-plate, enthalpy-core technology in the U.S., and is currently one of the largest ERV companies in the country. Committed to sustainability and protecting the environment, our manufacturing facility in Madison, WI is 100% powered by renewable energy and is on track to be one of the few buildings worldwide with LEED Gold, Green Globes and ENERGY STAR certifications. Our technology excels in every geography, every climate, every building and every application, enabling RenewAire to be everywhere. In 2010, RenewAire joined the Soler & Palau Ventilation Group, providing direct access to state-of-the-art, air-moving technology. For more information, visit: www.renewaire.com.

PURPOSE OF AN ENERGY RECOVERY VENTILATION (ERV) SYSTEM

Many modern homes are built air-tight for energy efficiency and comfort. The result is that natural air infiltration rates are often too low to provide acceptable indoor air quality. The solution is to use an ERV to remove gaseous pollutants such as odors, winter-time excess humidity, formaldehyde, smoke, radon, vapors from cleaning products, and other chemicals. The removal of dust and other small particles from your home is not the function of an ERV.

WHEN SHOULD YOU USE YOUR ERV?

Use your ERV when windows are closed and you need to ventilate. When the outdoor air is warmer or cooler than comfortable, the ERV will allow a quieter, more secure home with the windows closed and will also save energy.

USING AN ERV WITH AIR-CONDITIONING

An ERV works very well with air-conditioning, because its "enthalpy-transfer" energy-exchange core will reduce the amount of moisture in the outside air that is brought in. ERVs are the preferred way to ventilate while air-conditioning because it brings in less moisture than any other ventilation method.

CONTROLLING EXCESS HUMIDITY DURING COLD WEATHER

When the ERV is first turned on at the beginning of the heating season (or when first installed), it will have to run full-time for several days to reduce indoor humidity levels. A properly set dehumidistat will do this automatically. If your control is the proportional timer type (PTL or FM), it should be set to "100%" for several days whenever you have a problem with excess humidity during cold weather.

GR90, EV90, AND EV90P INFO

SPECIFICATIONS

ENERGY EXCHANGE SYSTEM

Cross flow fixed-plate enthalpic energy exchange core: engineered, proprietary resin-media composite. Provides both sensible and latent heat transfer.

CERTIFIED PERFORMANCE

See HVI Certified Ratings.

ACCESS DOOR

Front panel opens to provide access to filters, blowers, and energy exchanger. Snap latches and hinges provided for easy service.

INSULATION

One inch foil-faced EPS foam throughout.

MOUNTING OPTIONS

Unit may be mounted to wall or floor joists using integral mounting flange with hanging bracket kit provided. (EV90 and EV90P only, not GR90)

AIRFLOW BALANCING

Pressure ports located on door for flow measurement. Balancing damper provided for airflow correction.

BLOWER/MOTOR

Two high efficiency motorized impeller blowers provide quiet operation.

FILTERS

Cleanable polyester air filters for both exhaust and fresh air streams.

DEFROST

Passive frost-free design under most residential conditions.

WARRANTY

Ten year limited warranty on energy exchange core; five year limited warranty against defects in material and workmanship on all other components.

HVI CERTIFIED PERFORMANCE

HVI TESTED/CERTIFIED
PER CSA C439



EV90/GR90 - Ventilation Performance							
Ext. Static Pressure		Net Supply Airflow		Gross Airflow			
				Supply		Exhaust	
Pa	in. wg	L/S	CFM	L/S	CFM	L/S	CFM
25	0.1	53	113	54	115	52	109
50	0.2	46	98	47	100	46	97
75	0.3	40	85	41	87	40	85
100	0.4	34	73	35	74	34	72
125	0.5	27	58	28	59	28	60
150	0.6	19	40	19	41	22	47

Electrical Requirements Volts 120 Amps 0.35
Exhaust Air Transfer Ratio = 2.0% @ 0.2 in. wg (50 PA) and 2.0% @ 0.4 in. wg (100 Pa)

EV90/GR90 - Energy Performance							
Supply Temperature		Net Airflow		Average Power Watts	Sensible Recovery Efficiency %	Adjusted Sensible Recovery Efficiency %	Net Moisture Transfer %
C°	F°	L/S	CFM				
Heating							
0°	32°	42	90	46	72	77	37
					Total Recovery Efficiency %		Adjusted Total Recovery Efficiency %
35°	95°	42	90	44	46		48

EV90P - Ventilation Performance							
Ext. Static Pressure		Net Supply Airflow		Gross Airflow			
				Supply		Exhaust	
Pa	in. wg	L/S	CFM	L/S	CFM	L/S	CFM
25	0.1	51	108	52	110	52	110
50	0.2	47	99	48	101	47	100
75	0.3	41	87	42	89	42	89
100	0.4	35	73	36	75	36	76
125	0.5	26	56	27	57	27	58
150	0.6	20	42	20	42	21	44

Electrical Requirements Volts 120 Amps 0.35
Exhaust Air Transfer Ratio = 1.6% @ 0.2 in. wg (50 PA) and 2.0% @ 0.4 in. wg (100 PA)

EV90P - Energy Performance							
Supply Temperature		Net Airflow		Average Power Watts	Sensible Recovery Efficiency %	Adjusted Sensible Recovery Efficiency %	Net Moisture Transfer %
C°	F°	L/S	CFM				
Heating							
0°	32°	42	90	44	80	83	64
					Total Recovery Efficiency %		Adjusted Total Recovery Efficiency %
35°	95°	42	90	44	63		71



Energy Recovery Ventilator Standard



INDOOR UNIT

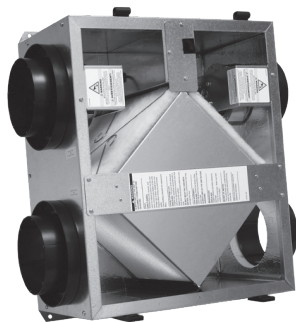

Download specification at:
renewaire.com/specifications

SPECIFICATIONS

Ventilation Type:
Static plate, heat and humidity transfer

Typical Airflow Range: 40-110 CFM

Standard Features:
Galvanized cabinet
Terminal strip hard wiring in ebox (no line cord)
Unit may be mounted in any orientation

Control:
Can use any switched line-voltage power supply (no low-voltage controls)

Filters:
Total qty. 2, MERV 8, spun-polyester media:
9 5/8" x 10 1/2" x 1"

Unit Dimensions: & Weight
22 1/2" L x 11 3/4" W x 23 3/4" H
36 lbs.

Max. Shipping Dimensions & Weight (in carton):
29" L x 22" W x 15" H
40 lbs.

Motor(s):
Qty. 2, Standard motorized impeller blowers

Accessories:
Backdraft damper 6"
Wall cap 6" - white, brown
120V line voltage Honeywell control

Note: Electric Duct Heater and Indirect Gas-Fired Duct Furnace are not available on the GR90.

ELECTRICAL DATA

HP	Volts	HZ	Phase	Input Watts	FLA
0.03	120	60	Single	46 @ 90 CFM	0.35

UNIT PERFORMANCE		CORE PERFORMANCE	
Airflow CFM	ESP in H ₂ O	Temp EFF%	Total EFF% Winter/Summer*
40	0.60	84	74/56
58	0.50	80	69/50
73	0.40	77	65/46
85	0.30	74	62/43
98	0.20	71	59/39
113	0.10	68	56/34

* See HVI certification ratings on page 164 of RenewAire's Full Line Volume XVIII Catalog.

UNIT DIMENSIONS

AIRFLOW CONFIGURATION
Available as shown in dimension drawing.

UNIT MOUNTING & APPLICATION
Can be mounted in any orientation. RA/EA airstream can be switched with OA/FA airstream.

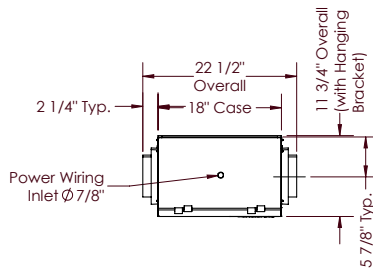

TOP VIEW

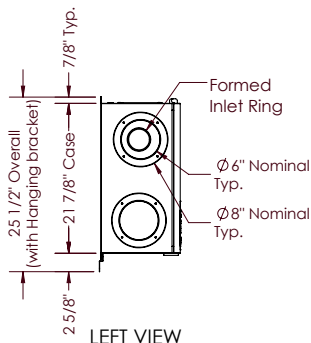

LEFT VIEW

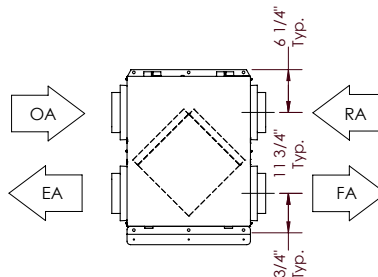

FRONT VIEW

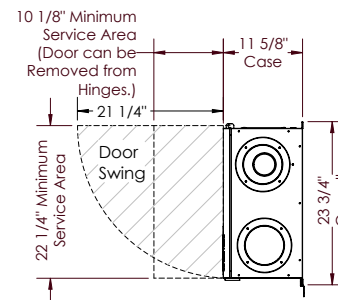

RIGHT VIEW

ABBREVIATIONS
EA: Exhaust Air to outside
OA: Outside Air intake
RA: Room Air to be exhausted
FA: Fresh Air to inside

INSTALLATION ORIENTATION
Unit may be installed in any orientation.

NOTE
1. UNLESS OTHERWISE SPECIFIED, DIMENSIONS ARE ROUNDED TO THE NEAREST EIGHTH OF AN INCH.
2. SPECIFICATIONS MAY BE SUBJECT TO CHANGE WITHOUT NOTICE.

Specifications may be subject to change without notice.

INDOOR UNIT

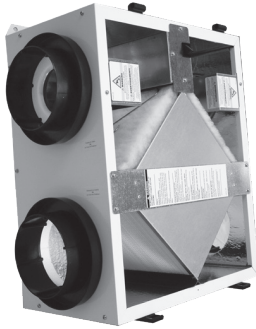

Download specification at:
renewaire.com/specifications

ELECTRICAL DATA

HP	Volts	HZ	Phase	Input Watts	FLA
0.03	120	60	Single	46 @ 90 CFM	0.35

SPECIFICATIONS

Ventilation Type:
Static plate, heat and humidity transfer

Typical Airflow Range: 40-110 CFM

Standard Features:
Painted cabinet
Line-cord power supply
Low-voltage circuit for controls
Unit may be mounted in any orientation

Control:
Onboard 24 VAC transformer/relay package with switched dry contacts

Filters:
Total qty. 2, MERV 8, spun-polyester media:
9 5/8" x 10 1/2" x 1"

Unit Dimensions & Weight:
22 1/2" L x 11 3/4" W x 23 3/4" H
36 lbs.

Max. Shipping Dimensions & Weight (in carton):
29" L x 22" W x 15" H
40 lbs.

Motor(s):
Qty. 2, Standard motorized impeller blowers

Accessories:
Backdraft damper 6"
Wall cap 6" - white, brown
Percentage timer control (PTL)
Push-button point-of-use controls (PBL), PTL req'd.
Percentage timer control with furnace interlock (FM)

Note: Electric Duct Heater and Indirect Gas-Fired Duct Furnace are not available on the EV90.

UNIT PERFORMANCE

Airflow CFM	ESP in H ₂ O
40	0.60
58	0.50
73	0.40
85	0.30
98	0.20
113	0.10

CORE PERFORMANCE

Temp EFF%	Total EFF% Winter/Summer*
84	74/56
80	69/50
77	65/46
74	62/43
71	59/39
68	56/34

* See HVI certification ratings on page 164 of RenewAire's Full Line Volume XVIII Catalog.

UNIT DIMENSIONS

AIRFLOW CONFIGURATION
Available as shown in dimension drawing.

UNIT MOUNTING & APPLICATION
Can be mounted in any orientation. RA/EA airstream can be switched with OA/FA airstream.

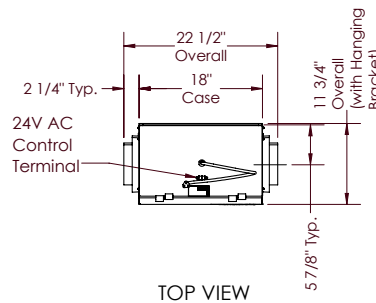

ABBREVIATIONS
EA: Exhaust Air to outside
OA: Outside Air intake
RA: Room Air to be exhausted
FA: Fresh Air to inside

INSTALLATION ORIENTATION
Unit may be installed in any orientation.

NOTE
1. UNLESS OTHERWISE SPECIFIED, DIMENSIONS ARE ROUNDED TO THE NEAREST EIGHTH OF AN INCH.
2. SPECIFICATIONS MAY BE SUBJECT TO CHANGE WITHOUT NOTICE.

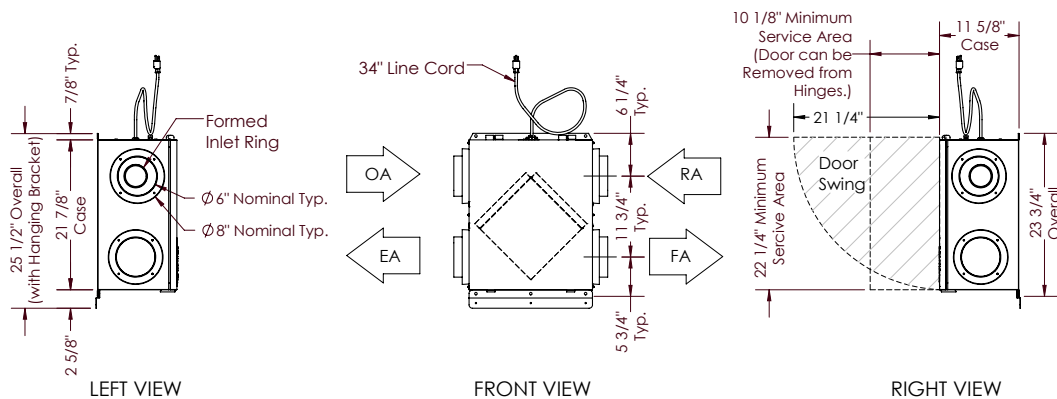

Specifications may be subject to change without notice.

INSTALLATION

BEFORE YOU BEGIN

Read all instructions before installing the unit. Also review supplemental instructions included with any controls that will be installed. Carefully unpack and inspect the unit for shipping damage. Open the access door and inspect inside the unit. Attach the four duct collars to the unit with the screws provided in the plastic small-parts bag.

LOCATION OF THE UNIT

Select a location so that:

- The fresh air intake vent from the outside is placed a minimum of ten feet from any other contaminated exhaust vent, and is at least 30" long.
- The two ducts to the outside are as short and straight as possible, for the best performance from the system. Shorter duct runs help assure that the system is balanced: the amount of air brought in is equal to the amount of air exhausted.
- The door can be opened to allow cleaning the core and filters. **Provide clearance at front of unit for service access to the blowers, filters and energy exchange core. (24" minimum.)**
- The exhaust outlet and fresh air inlet on the outside of the building should be at least ten feet apart to avoid cross-contamination. The exhaust duct should be about the same length as the fresh air duct.
- The exhaust outlet should not dump air into an enclosed space or into any other structure.
- Do not install the exhaust outlet and fresh air inlet through the roof. If these are the only available options call RenewAire technical support for help.

The preferred mounting location for the unit is on a concrete foundation wall because the foundation wall will isolate any blower vibration.

If a basement area is not available or practical, use other mechanical room space such as a closet, garage, storage, or accessible attic or crawl space.

NOTE: If you wish to install the unit in an attic or other unconditioned space, you must insulate all of the unit's ductwork that is located in the attic. Use at least R-6 insulation.

PLANNING YOUR INSTALLATION

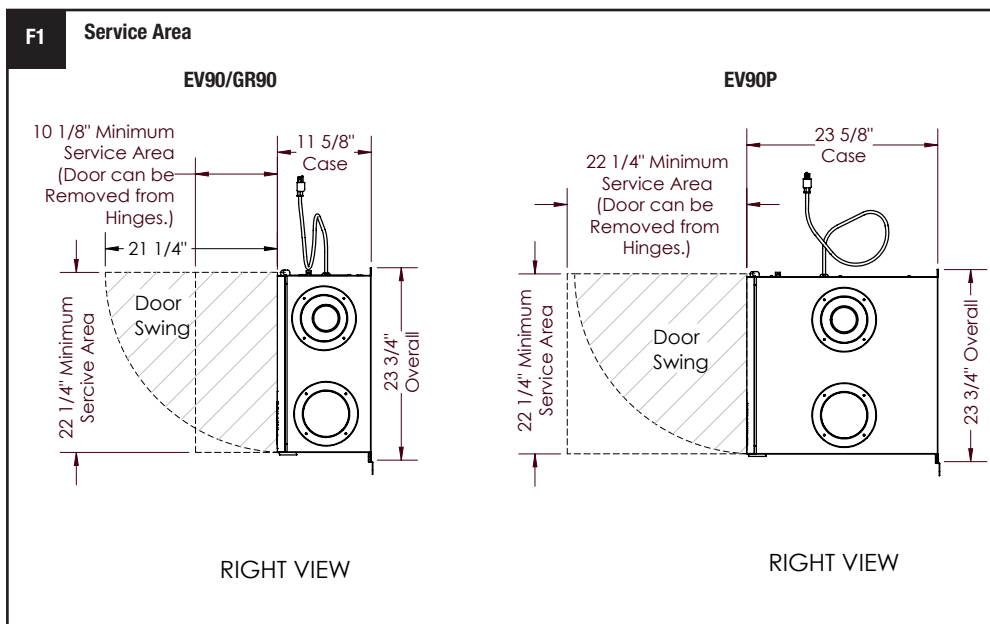

CAUTION

Provide Adequate Service Access for Maintenance. The unit will require regular filter and core inspections. Install the unit where you can access the core for cleaning and replacing the filters, and where you can get at the wiring for installation and service.

INSTALLATION

**PLANNING
YOUR INSTALLATION**

DUCTS TO THE OUTSIDE

The Exhaust Air Duct and the Outside Air Duct connect the unit to the outside. Flexible insulated duct is typically used. See Duct Sizes below.

DUCT SIZES

Exhaust Air & Outside Air (EA & OA)	6" round insulated duct 8" round insulated duct may be used to maintain maximum airflow
Fresh Air & Stale Air (FA & RA)	6" round or 8" oval rigid un-insulated
All ducts from unit to house in unconditioned spaces like attics and crawl spaces MUST BE INSULATED.	

INSIDE DUCTWORK SYSTEM

For houses without ducted heating or cooling systems – see Figure 3 (F3):

In most houses one or two fresh air grilles in a central part of the house provide effective distribution of the fresh air into the home, particularly when the stale exhaust air is picked up at several points. Because the fresh air is usually somewhat cooler than the household air, the fresh air supply grilles should be located in a traffic area like a hallway or stairway rather than in a sitting area. If you want to get fresh air into specific rooms with high occupancy, you can split up the fresh air supply.

For houses with forced-air heating and cooling systems – see Figure (F2), (F4) and (F5):

Most units are installed with the fresh air duct connected directly to a return duct for the main heating and cooling system. Be careful to connect the fresh air duct at least three feet from the return plenum to minimize suction from the furnace blower. A connection closer to the furnace may result in unbalanced flow and associated problems.

For installations that collect stale air from specific rooms in the home – see Figures (F2) and (F3):

Locate stale air return grilles (RA) in rooms where moisture and odors are generated: bathrooms, the kitchen, and perhaps other areas where contaminants are generated such as in the home workshop. Return grilles in these other areas may be dampered so that they can be shut off when not in use. A central location such as a hallway is also acceptable but won't clear humidity and odors from baths and kitchens as rapidly. Locate stale air

return grilles (RA) near the ceiling on inside walls. Stale air returns are usually easiest to install in interior partitions.

Stale Air Return Grille Sizes

Bathroom: 4" X 10" or 6" X 10" - 40 to 60 sq. in.
Kitchen: 6" X 10" or 60 sq. in.

Can an ERV be used to ventilate bathrooms?

A RenewAire ERV can be used as a central exhaust system in place of bathroom exhaust fans. Tie a grille in each bathroom directly back to the ERV – see Figure F2. A successful installation should provide at least 50 CFM of exhaust per moisture producing bathroom. When used for bathroom exhaust, the EV90/P should be used for only one bathroom. Install a control in the bathroom ventilated by the ERV (see Controls, page 12-13).

For houses where radon is a concern:

The first line of defense against radon should always be techniques that prevent the entry of radon into the home, such as under-slab suction, vented perimeter drainage, and crack sealing. However, if moderate levels of radon continue to be present, it is important that the unit slightly pressurize the basement, not de-pressurize the basement.

Installation of this unit for radon mitigation is beyond the scope of this manual. Consult a radon mitigation professional.

⚠ WARNING

DO NOT PLACE ANY STALE AIR RETURNS IN GARAGES.

INSTALLATION

APPLICATIONS

See figures F2-F5 for examples of some common installation approaches.

PLANNING YOUR INSTALLATION

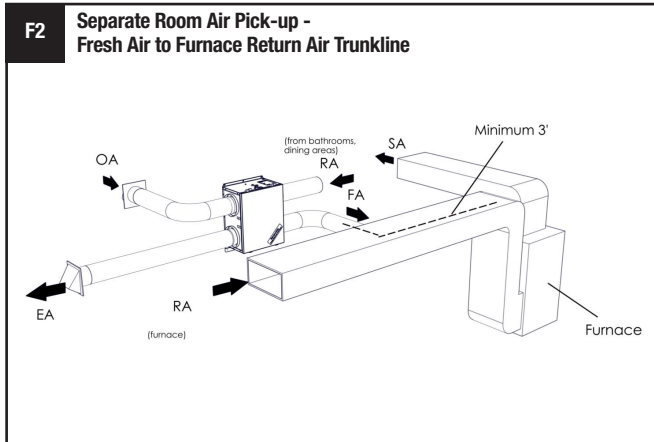

Note: ERV blower may be operated separate from furnace blower.

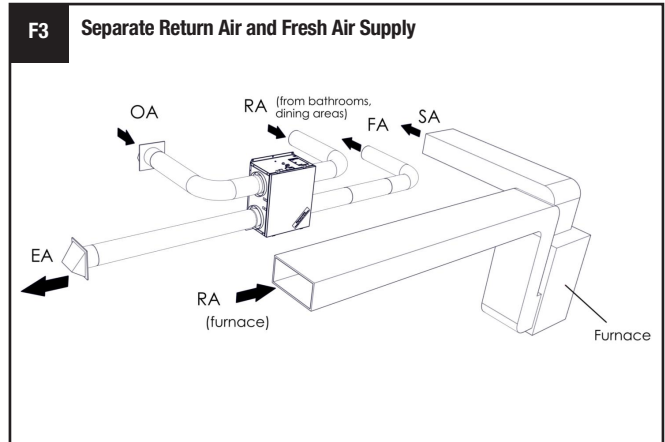

Note: ERV blower may be operated separate from furnace blower.
*Use caution to introduce FA at low velocity and where good mixing will occur to minimize discomfort from drafts.

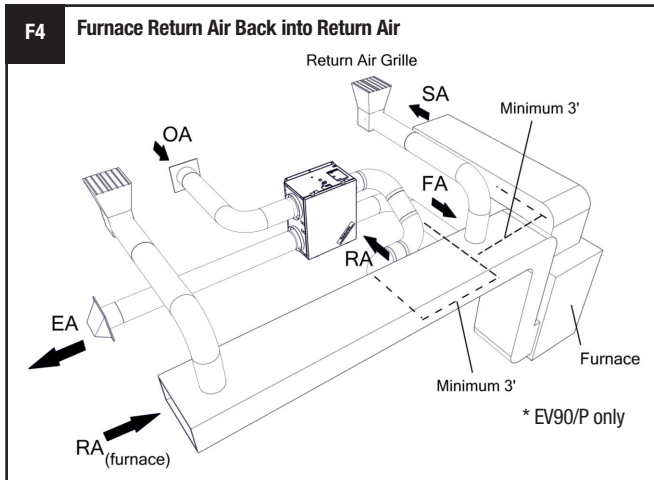

Note: The furnace blower must be operated any time the ERV is operated. Use furnace fan "on" continuous low speed or optional FM control to cycle furnace fan on ERV.

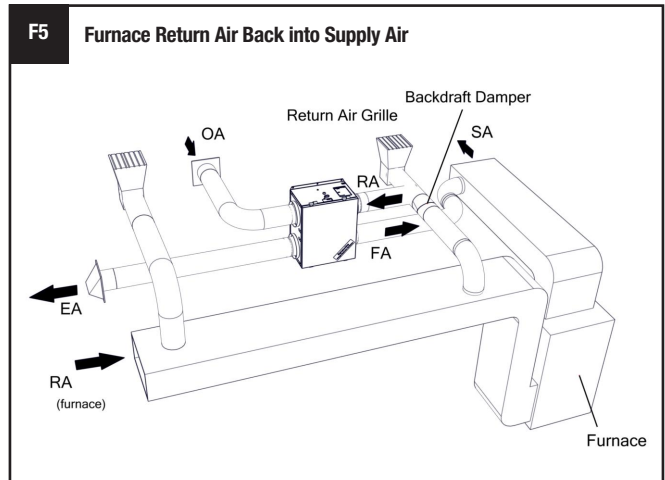

Note: ERV blower may be operated separate from furnace blower.

- EA Exhaust Air
- OA Outside Air
- RA Room Air
- SA Supply Air
- FA Fresh Air

INSTALLATION

PLANNING
YOUR INSTALLATION **WARNING****RISK OF FIRE, ELECTRIC SHOCK, OR INJURY. OBSERVE ALL CODES AND THE FOLLOWING:**

1. Before servicing or cleaning the unit, unplug the unit line cord or shut off power at service switch or circuit breaker. Make sure unit is not running before opening its door.
2. This installation manual shows the suggested installation method. Additional measures may be required by local codes and standards.
3. Installation work and electrical wiring must be done by qualified professional(s) in accordance with all applicable codes, standards and licensing requirements.
4. Any structural alterations necessary for installation must comply with all applicable building, health, and safety code requirements.
5. Connect this unit only to a 120VAC grounded circuit protected by a 15 amp circuit breaker.
6. Do not install unit or controls where they can be reached from a tub or shower.
7. This unit must be properly ducted to the outdoors.
8. Outside air inlet for this unit must be located away from sources of hazardous air such as auto exhausts.
9. Sufficient air is needed for proper combustion and exhausting of gases through the flue (chimney) of fuel burning equipment that might be installed in the area affected by this equipment. If this unit is exhausting air from a space in which chimney-vented fuel burning equipment is located, take steps to assure that combustion air supply is not affected. Follow the heating equipment manufacturer's requirements and the combustion air supply requirements of applicable codes and standards.
10. This unit is intended for general ventilating only. Do not use to exhaust hazardous or explosive materials and vapors. Do not connect this unit to range hoods, fume hoods or collection systems for toxics.
11. When cutting or drilling into wall or ceiling, do not damage electrical wiring and other hidden utilities.
12. Use the unit only in the manner intended by the manufacturer. If you have questions, contact the manufacturer.

CAUTION

1. To avoid motor bearing damage and noisy and/or unbalanced impellers, keep drywall spray, construction dust, etc., out of the unit.
2. Do not connect power to the units external control terminals: this will damage the unit. The external terminals are for use only with un-powered controls designed for low-voltage operation.

INSTALLATION**MOUNTING THE UNIT****Unit may be installed in any orientation**

Orient the unit for the simplest duct layout and connections. Note however that the door is equipped with slide-off hinges. For the homeowner's convenience it is helpful to orient the unit so that the door does not drop off when it is unlatched.

Mounting the EV90/P on a concrete foundation wall

Mount hanging bracket to the wall with appropriate concrete anchors. Use pre-cut foam tape from small parts bag. Remove backing and apply two pieces of foam tape equally spaced along the unit's mounting flange to be held by the hanging bracket. Apply the other two pieces of foam over two holes that will be used for fastening, on the other flange. The tape should be applied in a "U" shape to cushion both the front and back of the integral flanges. Lift unit and slide unit flange into the hanging bracket. Using metal flat washers, fasten flange opposite hanging bracket to structure. Safety screws should similarly be installed passing through the hanging bracket and flange. Make sure the screws, which you must supply, are properly selected for the loads and substrate involved.

Mounting the EV90/P to a stud wall

Mount unit using supplied hanging bracket kit as described for mounting to concrete foundation wall. Note that the hole layout on the integral mounting flanges and the hanging bracket are spaced for 16" on-center framing patterns.

Suspending the EV90/P from floor joists or trusses

The unit may be screwed directly to joists or trusses using the hanging bracket and integral flange. Mount as described for mounting to concrete foundation wall. Note that the hole layout on the hanging bracket is spaced for 16" on-center layouts.

Mounting the GR90

The GR90 can be mounted similar to the EV90 however, the GR90 does not come with a hanging bracket. Using flat washers provided, install screws through the holes in the flanges of the unit. Make sure the screws, which you must supply, are properly selected for the loads and substrate involved.

ELECTRICAL CONNECTIONS**NOTE: DISCONNECTION MEANS**

Most electrical codes require that the unit be disconnected for service. Depending on local codes, an electrical outlet (for EV90/P) or an on/off switch available for the unit (GR90) may satisfy this requirement.

Power supply connection to GR90 is made in its electrical box through the hole in the end pan. Pull out the unit electrical box and connect the power wire conductors to the terminal block inside the electrical box. The terminal block inside the electrical box is conveniently marked for connection of field power wiring. After connecting the power wire conductors to the terminal block re-install the electrical box in the unit.

RenewAire offers the EV90/P with a line cord for connection to an electrical outlet. If an EV90/P with a line cord is installed and the installer desires to convert to field power wiring, should local codes permit, simply remove the line cord from the terminal block and connect field wiring as described above.

INSTALLATION INSTRUCTION**CAUTION**

Risk of injury when lifting unit and installing it overhead. Get a helper and wear eye protection.

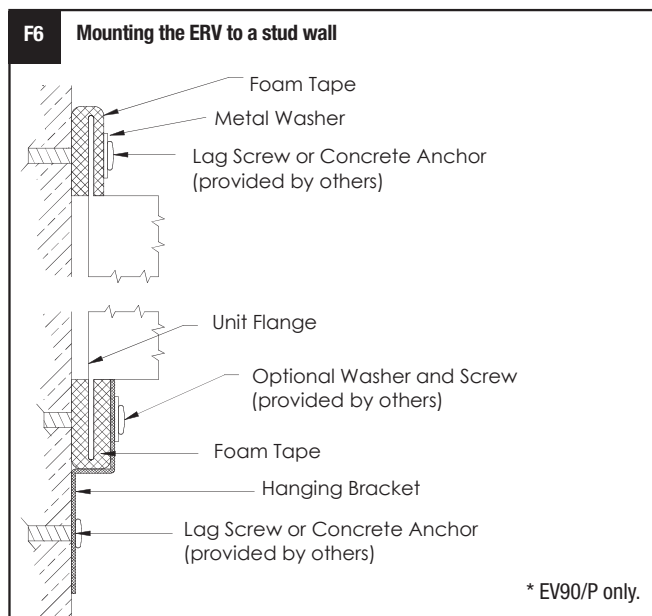

INSTALLATION

INSTALLATION INSTRUCTION

INSTALLING OUTSIDE AIR AND EXHAUST AIR DUCTS

Ducts connecting the unit to the outside must be well-insulated. Vapor barrier is required on both inside and outside of the insulation.

Band or tape inner duct liner to inner flange of appropriate collar. Drive a sheet metal screw through liner to secure duct spiral wire to collar. Straighten insulation, and slide outer duct jacket onto the outer flange of the duct collar. Secure with band or tape.

CAUTION

Do not place any stale air returns in garages.

CAUTION

Do not connect Dryers to unit. Do not connect Range Hoods to the unit.

CAUTION

INSTALL FRESH AIR INLET AWAY FROM SOURCES OF CONTAMINANTS.

- Do not locate the fresh air inlet where vehicles may be serviced or left idling.
- The fresh air inlet should be at least ten feet away from any exhaust such as dryer vents, chimneys, furnace, and water heater exhausts or other sources of contamination or carbon monoxide.
- Install 12" above ground level.
- Never locate the fresh air inlet inside a structure.

CAUTION

The vapor barrier should be continuous and sealed against air and moisture leakage! If not, condensation or ice may form in cold weather on the duct surface or in its insulation!

The inlets and outlets should be screened against insects and vermin and shielded from the weather to prevent the entry of rain or snow.

INSTALLING RETURN AIR (RA) DUCTS:

All the stale air returns are connected by ducts to the unit. Generally, empty stud cavities are used for returns as is often done with cold air returns for the furnace, using standard duct boots to connect to six inch pipe at the bottom or top of the wall cavity. Always be sure to seal all joints with duct sealant or tape. Some local codes may require metal ducting all the way from the boots to the stale air grilles. Use rigid ducts to allow the air to move freely and easily through the ducts. See chart under Exhaust and Outside Air Ducts to size your ductwork.

If duct runs are very long (over 30 feet of flex duct for 90 CFM) or have excessive bends or elbows or if maximum air flow rates are required, eight inch insulated flexible duct should be used. The outer flange of the duct collar can be used for both the inner and outer jacket of the flexible duct. Care must be taken to ensure that the duct is securely fastened and sealed to the duct collar.

Do not use more flex duct than necessary!

Flex duct is much more resistant to airflow than rigid duct; longer runs of flex duct will reduce the ventilation performance of your system. Stretch flex duct and avoid sharp bends.

NOTE: Seal all duct collars at unit to minimize air leakage.

CONTROLS

For an installation in which the ERV should run continuously in order to provide the required ventilation rate for the home, no controls are needed. However, in most installations, control over the unit operation is desired and this is best provided by a Proportional Timer.

Proportional timers (PTL or FM controls for EV90/P or line voltage controls for GR90) may be located anywhere that is convenient. A typical location for

either control is next to the home's thermostat. Proportional timers operate the ERV to provide regular background ventilation of the home.

EV90/P installations that pull stale air from specific rooms, such as bathrooms, should have Push-Button Lighted (PBL) Controls in those rooms. The secondary operating controls allow the system to be turned on from various locations in the house.

INSTALLATION**INSTALLATION INSTRUCTION****⚠ WARNING**

DANGER OF ELECTRICAL SHOCK WHEN SERVICING AN INSTALLED UNIT.
ALWAYS UNPLUG UNIT BEFORE CONNECTING OR SERVICING CONTROLS.

INSTALLING CONTROLS

The EV90/P is offered with a control board for connection to external controls. The GR90 runs continuously whenever power is supplied to it.

Optional controls:

RenewAire offers a variety of controls specifically designed to work with the EV90/P. These include: PTL (a two wire proportional timer), FM (a six wire proportional timer that interconnects to the furnace blower), and PBL (point of use push button control). Other controls that throw an unpowered switch may also be used.

The GR90 is a line voltage unit that may be controlled with any line voltage control switch.

Typical control schematic:

Various wiring designs can be used to properly control the unit and meet safety and code concerns. Consult your electrician for an electrical design to meet your needs. The schematic below shows a typical control system: a PTL proportional timer plus two PBL push-button controls.

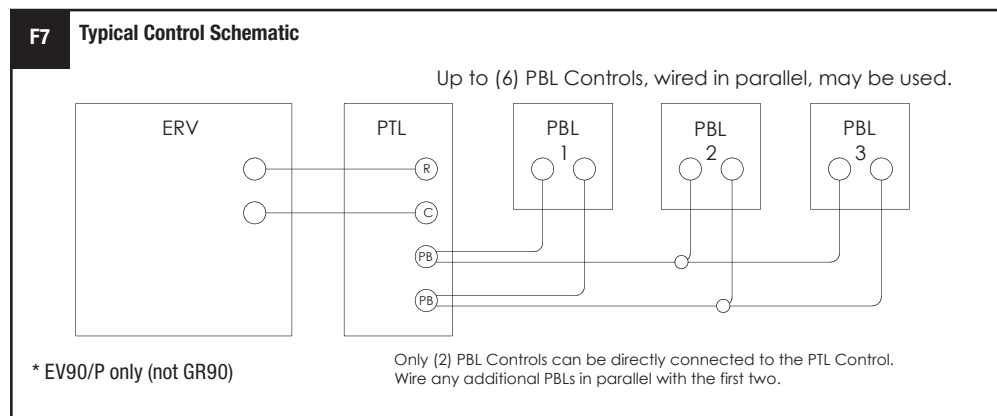

See installation manuals for the control(s) you select for wiring diagrams and specific instructions.

If NOT connecting controls to the EV90/P:

Make a jumper out of a short piece of wire. Connect the jumper wire to the screw connections of the terminal strip on the outside of the unit. ERV runs full-time once its power cord is plugged in.

STARTING UP THE UNIT

- Inspect your installation to be sure all duct work is correctly installed and sealed, that filters are in place, and controls (if any) are connected.
- Shut and latch the door to the unit.
- Provide 120 VAC power to the unit. It may start immediately.
- Use control, if any, to turn on the unit. Check operation of the control(s).
- Check that the unit's safety interlock switch turns off the unit when the door is opened.

OPERATION & START-UP**START-UP**

START-UP & OPERATION

OPERATION VERIFYING UNIT PERFORMANCE

Airflow

Airflow should be occurring in both airstreams. Sometimes the easiest place to confirm that air is moving is at the external wall caps.

If exact airflow is critical, it may be desirable to permanently install flow measuring stations and manometers. These can also be used to determine when filters should be cleaned or changed.

Use Static Taps to Measure Aiflow Rates

See "Cross Core Static Drop" in MEASURING AIRFLOW table on page 15.

Use Damper to Balance Air Flow to Desired Rates, if necessary

The ERV's blower motor are well suited for volume control by dampers on the inlet of the unit. One balancing damper is provided in the unit parts tray. **NOTE:** The unit is considered balanced if the difference between the two airflows is not more than 10 CFM.

After measuring the airflow of the unit, the balancing damper may be used to balance airflow if desired. Place the damper between the duct collar and the unit for the outlet of the airstream recording higher flow. **NOTE:** Install the damper so that it slides in the space between the duct collars for the EV90 and the GR90. Install the damper so that it slides from the door of the unit down to the duct collar for the EV90P.

Slowly move the damper further into the duct until the desired airflow is recorded. Secure the damper in place using 1/8" tek screws (provided). **NOTE:** Drilling through the case while the unit is running may cause metal shards to be drawn into the unit.

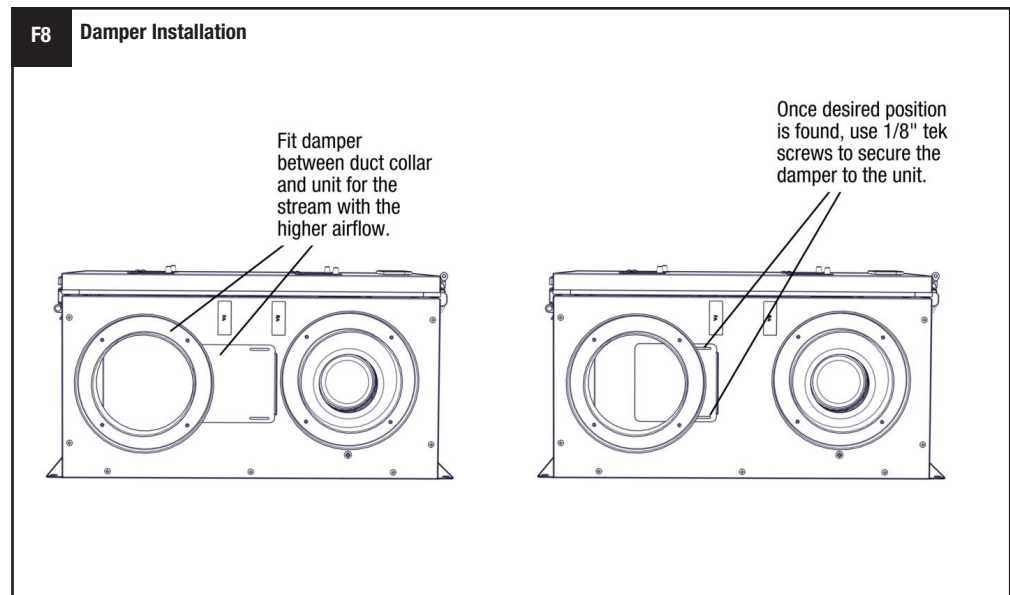
F8 Damper Installation

START-UP

EQUIPMENT REQUIRED

- A magnehelic gauge or other device capable of measuring 0 to 1.0 in. water of differential pressure.
- 2 pieces of natural rubber latex tubing, 1/8" ID, 1/16" Wall works the best.

CROSS CORE STATIC PRESSURE MEASUREMENT INSTRUCTIONS

The individual differential static pressures (DP) are measured using the installed pressure ports located in the front of the units core access doors.

NOTE: These ports are carefully located on the unit to give the most accurate airflow measurement.

Do not relocate pressure ports.

- To read SCFM of Fresh Air (FA) install the "high" pressure side (+) of your measuring device to the Outside Air (OA) port and the "low" pressure side (-) to the Fresh Air (FA) port.
- To read SCFM of Room Air (RA) install the "high" pressure side (+) of your measuring device to the Room Air (RA) port and the "low" pressure side (-) to the Exhaust Air (EA) port.

NOTE: Be sure to remove cap from pressure port before inserting tubing. Insure tubing is well seated in pressure ports.

NOTE: The tubing should extend in the pressure port approx. 1 inch.

- If gauge drops below zero, reverse tubing connections.
- Use the reading displayed on your measurement device to cross reference the CFM output using the conversion chart.

NOTE: Be sure to replace cap into pressure port when airflow measuring is completed.

NOTE: For best performance the airflow rate for both the Fresh Air and the Exhaust Air should be roughly equal ("balanced"). In some facilities a slight positive or negative pressure in the building is desired. RenewAire energy recovery ventilators can generally operate with a flow imbalance of up to 20% without significant loss in energy recovery efficiency.

MEASURING AIR FLOW

CAUTION

Make sure clean filters are installed before balancing air flow. Dirty or clogged filters reduce airflow through the unit.

CAUTION

The proper airflow range for the models are 40-110 CFM

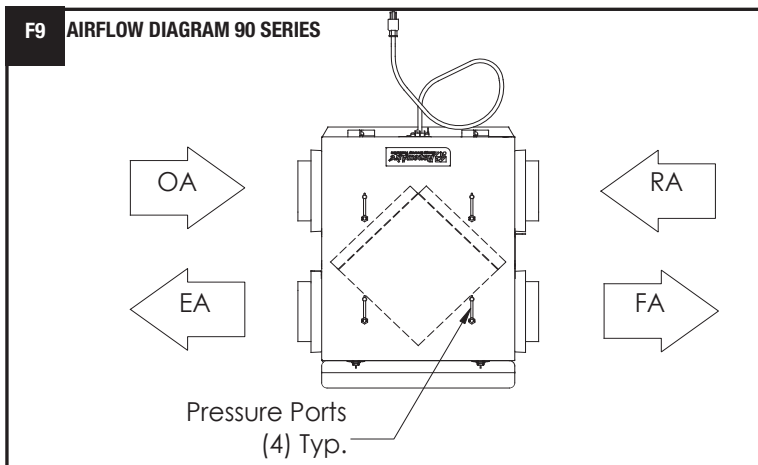

DIFFERENTIAL STATIC ACROSS CORE DSP VS. CFM					
EV90, GR90		DSP	0.10	0.20	0.30
	Fresh Air (FA)	CFM	42	84	127
	Room Air (RA)	CFM	42	84	127

DIFFERENTIAL STATIC ACROSS CORE DSP VS. CFM					
EV90P		DSP	0.10	0.20	0.30
	Fresh Air (FA)	CFM	58	115	173
	Room Air (RA)	CFM	58	115	173

THIS PAGE LEFT BLANK

THIS PAGE LEFT BLANK

MAINTENANCE

SERVICE PARTS GR90, EV90, AND EV90P

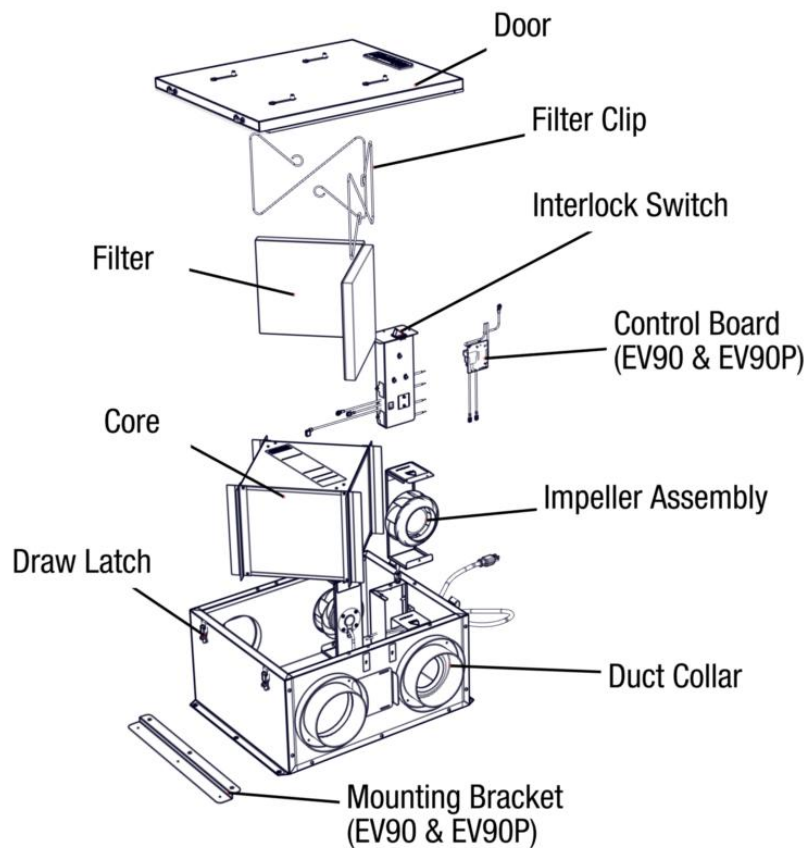

MAINTENANCE

Keep your ERV performing at its best by cleaning it as described below:

TO CLEAN THE ENERGY EXCHANGE ELEMENT

1. Remove the filters (see below).
2. Vacuum the exposed faces of the energy exchange core with a soft brush attachment.
3. After servicing the filters, re-install them (see below).
4. Vacuum out dust from the rest of the unit case. Dust collects only on the entering faces of the energy exchange core. The interior of the energy exchange core stays clean even if the core faces are dust covered. The RenewAire core airflow paths are designed to transport the air in a laminar motion. The core flutes move the air in a laminar airflow such that particulate deposition is maintained at virtually nil.

INSPECT AND CHANGE THE FILTERS REGULARLY

Service filters every three months when the unit is in regular use or as needed to keep them reasonably clean.

1. Release cam latches and carefully swing access door open. Remove the door by sliding to one side.
2. Remove filter clips.
3. Pull the filters out.
4. Vacuum with a hose attachment.
5. Re-install filters and filter clips, (see Service Parts, page 14). Orange side of filter should face the core.
6. Re-install door, and fasten cam latches.

NOTE: The filters should be replaced after they have been cleaned several times. The primary contact for replacement filters for your RenewAire unit is the installing contractor. As an alternative, you may wish to produce your own filters. Please follow these instructions:

Filters may be cut from a sheet or roll of ¾" - 1" firm, spun polyester filter "hog hair" media or material, similar to the existing filter in the residential unit.

The size of each filter (2 required per unit) is as follows:

EV90/GR90	9 ½" x 10 ½"
EV90P	21 ¾" x 10 ½"

Call your HVAC contractor or RenewAire for further information.

NOTE: Filters must be used or the face of the energy exchange core will become blocked by dust and reduce unit efficacy. The filters supplied in the unit are usually able to keep the energy exchange core clean for many months. Finer filters can be used but must be cleaned more often.

MOTOR MAINTENANCE

The blower/motor package needs no lubrication:

Vacuum clean the blower wheels at the same time you clean the face of the energy exchange core. Confirm blower wheel is not rubbing against the blower inlet or housing by rotating wheel manually.

GENERAL CLEANING AND INSPECTION

Perform general cleaning and visual inspection when changing filters.

1. Remove paper, leaves, etc. from inlet and outlet screens.
2. Inspect for insect nests.

REQUIREMENTS

WARNING

**RISK OF ELECTRIC SHOCK
OR INJURY.**

- Before servicing or cleaning the unit, unplug the unit line cord.
- Make sure unit is not running before opening its door. Blower wheels are sharp and can cut.
- Do not disable the interlock switch: it is there for your safety.

CAUTION

**DO NOT WASH THE ENERGY
EXCHANGE CORE.**

Keep it away from water or fire to avoid damaging it. Always handle the core carefully.



UNMATCHED VENTILATION SUPPORT

As much as our unsurpassed quality and performance, our customers can also depend on our professional support staff for swift, professional assistance with all their technical, application, and service needs. **Every time. Anywhere.**

At RenewAire — unlike other ventilation suppliers — advanced ventilation solutions are all we do. Our sole passion. Which is why for all commercial projects, we are the “V” in HVAC... and the only name you need to know.

USA

(800) 627-4499
FAX: (608) 221-2824
201 RAEMISCH ROAD
WAUNAKEE, WISCONSIN 53597 USA
WWW.RENEWAIRE.COM

CANADA

(905) 475-8989
FAX: (905) 475-5231
WWW.MITSUBISHIELECTRIC.CA

MEXICO, CENTRAL & SOUTH AMERICA

52 (222) 2 233 911
FAX: 52 (222) 2 233 914
WWW.SOLER-PALAU.MX