

CAST IRON SOLID PLUGS CLASS 125

NPS	Nominal Width Across Flats A	Distance Between Lugs B (min)	Length of Threads C (min)	Height of Square D (min)
*1/8	9/32	—	0.37	0.24
*1/4	3/8	—	0.44	0.28
*1/2	9/16	—	0.56	0.38
*3/4	5/8	—	0.63	0.44
*3/8	7/16	—	0.48	0.31
1	13/16	—	0.75	0.50
1 1/4	15/16	—	0.80	0.56
1 1/2	1 1/8	—	0.83	0.62
2	1 5/16	—	0.88	0.68
2 1/2	1 1/2	—	1.07	0.74
3	1 11/16	—	1.13	0.80
3 1/2	—	—	—	—
+ 4	—	7/8	1.22	1.00
+ 5	—	7/8	1.31	1.00
+ 6	—	1 1/4	1.40	1.25
+8	—	—	—	—

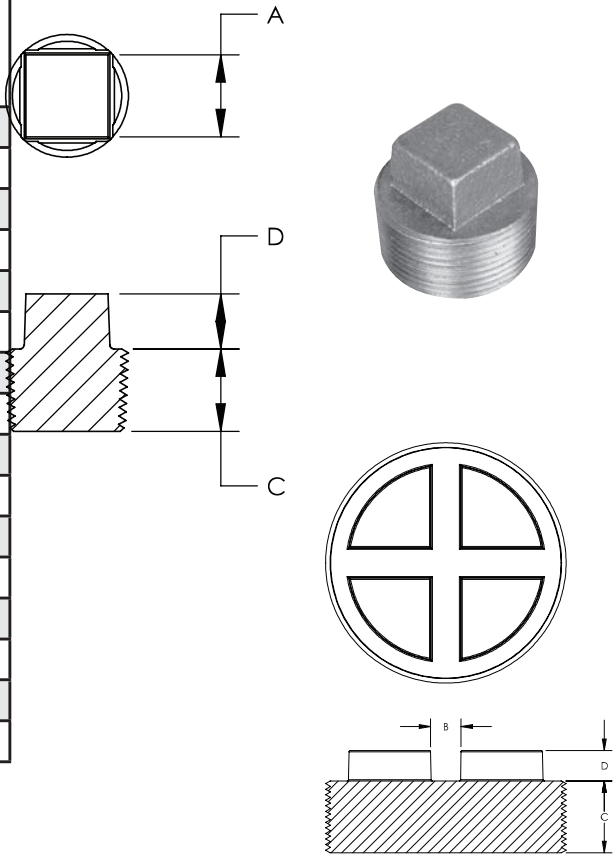

*Made from Cast Iron or Steel

+ Bar Head

CAST IRON CORED PLUGS CLASS 125

NPS	Nominal Width Across Flats A	Distance Between Lugs B (min)	Length of Threads C (min)	Height of Square D (min)
1/2	9/16	---	0.56	0.28
3/4	5/8	---	0.63	0.44
1	13/16	---	0.75	0.50
1 1/4	15/16	---	0.80	0.56
1 1/2	1 1/8	---	0.83	0.62
2	1 5/16	---	0.88	0.68
2 1/2	1 1/2	---	1.07	0.74
3	1 11/16	---	1.13	0.80
3 1/2	1 7/8	---	1.18	0.86
4 SQUARE	2 1/16	---	1.22	0.92
+ 4	---	7/8	1.22	1.00
+ 5	---	7/8	1.31	1.00
+ 6	---	1 1/4	1.40	1.25
+8	---	---	---	---

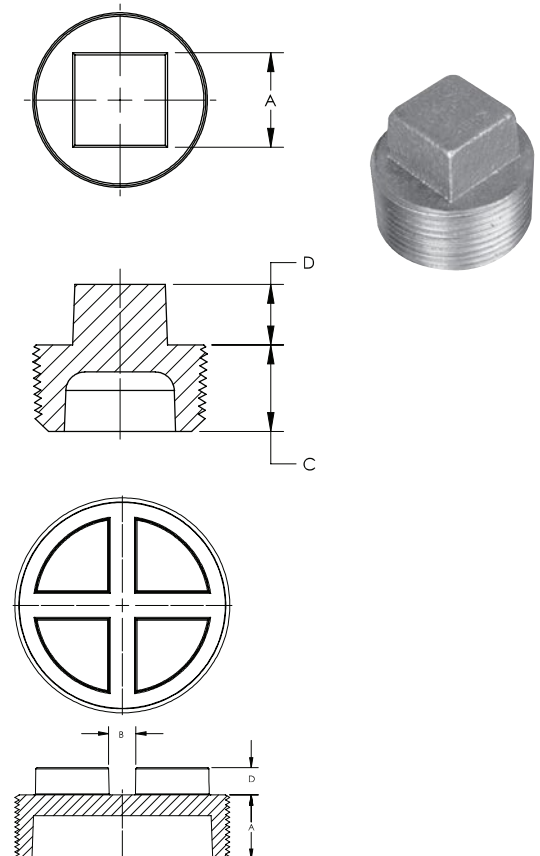

+ Bar Head