

TECHNICAL SPECIFICATIONS

CONNECTIONS



DISHWASHER



SINK



SHOWER



BATHTUB



LAUNDRY
SINK



WASHING
MACHINE

APPLICATIONS



COMMERCIAL

Sanicom[®]1 Drain Pump



Example of installation. Follow local plumbing codes for actual install.

The **Sanicom 1 drain pump** is used to pump gray water away from a variety of fixtures in **commercial applications**. The system is able to discharge the waste up to **25 feet vertical and/or 250 feet horizontal**. This model was designed to sustain the toughest applications in commercial installations where hot water can be an issue as it is **capable of handling up to 194°F as well as grease**.

- **Discharges the waste through a 1" rigid pipe.** The system includes a rubber discharge fitting that adapts to the discharge pipe as well as a **non-return valve**.
- Has been designed with a **1-1/4" vent connection** on top of the system. All plumbing codes require connection to a vent system. Please note that the vent system should be a two-way air vent as air needs to freely flow both ways. Note: The use of mechanical vents, air admittance valves or similar devices is not permitted.
- Discharges **gray water from commercial kitchens, dishwashers, washing machines, etc.** The gray water will drain into the system **via two 2" inlets** which are on either side of the housing. Note that when draining wastewater into the pump through either of the side inlets, an external check valve (not supplied) has to be installed.
- Able to **handle liquids with highly acidic** properties as system activates with a **fail proof air pressure switch system with triple redundancy**.

AN EASY SOLUTION FOR COMMERCIAL APPLICATIONS REQUIRING GRAY WATER REMOVAL

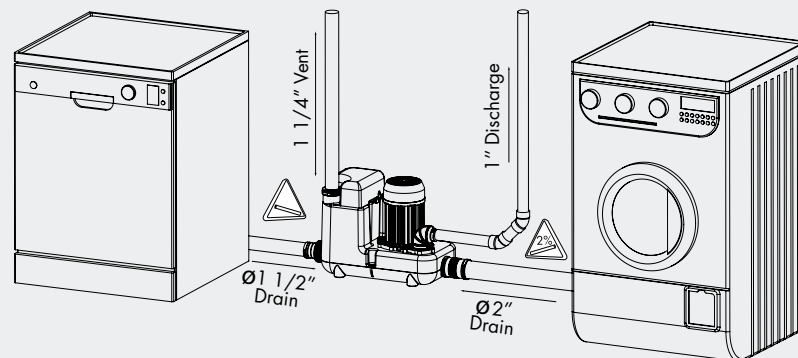

Powerful 1 HP drain pump for commercial applications where hot water can be an issue as it is capable of handling up to 194°F.

System is **capable of handling multiple fixtures simultaneously**. Powerful motor for absolute reliability and efficiency.



Commercial Grade

PUMPING DISTANCE

25 Ft

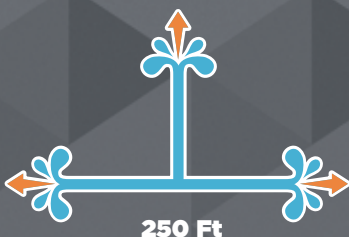

250 Ft



TECHNICAL SPECIFICATIONS

PLEASE CALL US TOLL-FREE AT
800-571-8191 (US) / 800-363-5874 (CDN)
 TO PURCHASE PARTS REFERENCED BELOW

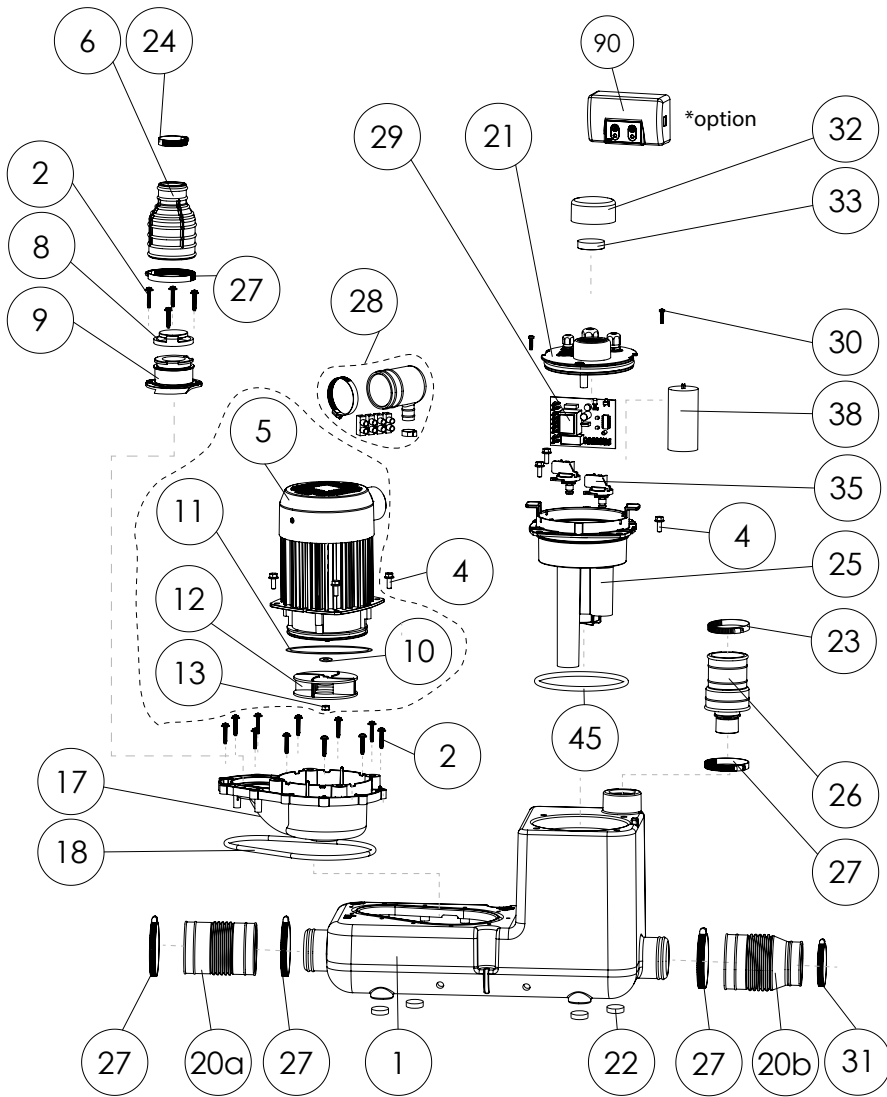

TECHNICAL SPECIFICATIONS

Pump type:

Drain pump

Electrical:

120 V - 60 Hz / 8.3 Amps (Max)

Motor:

1.3 HP oil-filled thermally protected motor

Capacitor rating:

45 microfarad

Operating Temperature:

194°F Max.

Power cord length:

50 inches

Noise level:

≤ 68 dBA (Lp) (measured at 3 ft.)

Discharge pipe diameter:

1"

Discharge rate at 25 ft:

22 GPM

Discharge rate at 3 ft:

50 GPM

Shut-off head:

44 ft.

Normal running time:

4-6 Seconds (Short bursts)

Capacity:

2.75 gallons / 10.4 liters

Inlets:

2" (sides), 1-1/4" vent (top)

Method of activation:

Pressure switch/ circuit board

Shower/bathtub base height:

10" min

Weight:

22 lbs / 10 kg

Certifying agencies:

CSA (IPC, NSPC), IAPMO (UPC)

Recommended accessories:

Descaler

Connections:

Commercial sink, dishwasher, washing machine, etc

DIMENSIONAL DRAWINGS

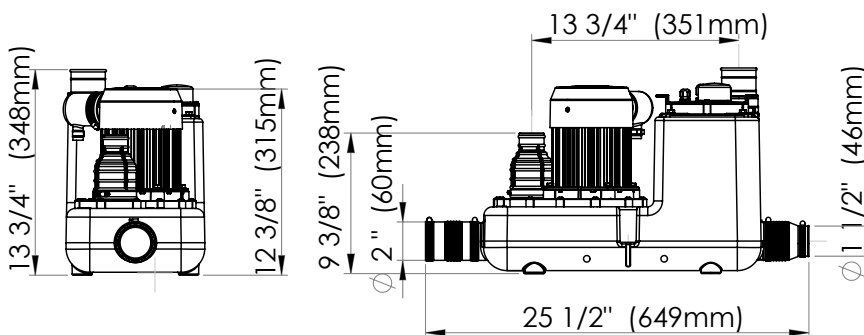

Pump gray water away from any commercial application.

