

# INSTALLATION INSTRUCTIONS

## AIR HANDLERS

FEATURING INDUSTRY STANDARD R-410A REFRIGERANT: 

(-)H2T High Efficiency 2-Stage with Aluminum Coil

(-)HMV High Efficiency Variable Speed with Aluminum Coil  
Equipped with Rheem EcoNet™ Communications



RECOGNIZE THIS SYMBOL AS AN INDICATION OF IMPORTANT SAFETY INFORMATION!

### ▲WARNING

These instructions are intended as an aid to qualified licensed service personnel for proper installation, adjustment and operation of this unit. Read these instructions thoroughly before attempting installation or operation. Failure to follow these instructions may result in improper installation, adjustment, service or maintenance possibly resulting in fire, electrical shock, property damage, personal injury or death.



ISO 9001:2008

Certificate Number: 30164

**DO NOT DESTROY THIS MANUAL**

**PLEASE READ CAREFULLY AND KEEP IN A SAFE PLACE FOR FUTURE REFERENCE BY A SERVICEMAN**



# TABLE OF CONTENTS

<b>1.0</b>	<b>SAFETY INFORMATION</b>	<b>3</b>
<b>2.0</b>	<b>GENERAL INFORMATION</b>	<b>5</b>
2.1	Important Information About Efficiency and Indoor Air Quality	5
2.2	Receiving	6
2.3	Clearances	6
2.4	Model Number Explanation	7
2.4A	Available Models	8
2.5	Dimensions and Weights	9
<b>3.0</b>	<b>APPLICATIONS</b>	<b>10</b>
3.1	Vertical Upflow	10
3.2	Vertical Downflow	10
3.3	Installation in an Unconditioned Space	12
3.4	Installation in Mobile/Manufactured Homes	13
<b>4.0</b>	<b>ELECTRICAL WIRING</b>	<b>14</b>
4.1	Power Wiring	14
4.2	Grounding	14
4.3	Electrical Wiring	14
4.4	Electrical Data – Blower Motor	16
4.4A	Electrical Data – Blower Motor (-)H2T	16
4.4B	Electrical Data – Blower Motor (-)H2V	16
4.5	Copper Wire Size	16
4.6	Electric Heat Electrical Data	17
4.6A	Electric Heat Electrical Data: (-)H2T	17-18
4.6B	Electric Heat Electrical Data: (-)H2V	19-20
4.6C	Electric Heat Electrical Data: (-)H2V	20
4.7	Heater Kit Supplemental Information	21
<b>5.0</b>	<b>AIR HANDLER EQUIPPED WITH ECONET™ COMMUNICATIONS</b>	<b>22</b>
5.1	EcoNet™ Air Handler Physical Interface	22
5.2	EcoNet™ Control Board Communication Wiring	23
5.3	Conventional 24VAC Thermostat Control Wiring	24
5.4	EcoNet™ Control Wiring	24
5.5	Using the On-Board LED to Determine Blower CFM	25
5.6	Airflow Adjustments with the EcoNet™ Air Handler	25
5.6.1	Cooling Airflow Settings (By Tonnage)	25
5.6.2	Cooling Airflow Adjustment (Trim)	26
5.6.3	Cooling/Heating Airflow Settings	26
5.6.4	Electric Heat Airflow	27
5.7	Cooling Mode Dehumidification	28
5.8	Air Handler Diagnostic Codes	31
<b>6.0</b>	<b>AIRFLOW PERFORMANCE</b>	<b>37</b>
6.1	Airflow Performance Data	37-43
<b>7.0</b>	<b>DUCTWORK</b>	<b>44</b>
<b>8.0</b>	<b>REFRIGERANT CONNECTIONS</b>	<b>44</b>
8.1	Electronic Expansion	44
8.2	EXV Vapor Line Thermister	45
8.3	Factory Programmed Superheat	46
8.4	Superheat Offset Dip Switch Settings	46
8.5	EXV Step Dip Switch	46
8.6	Diagnostics	46
8.7	Condensate Drain Tubing	46
8.8	Duct Flanges	47
<b>9.0</b>	<b>AIR FILTER (not factory installed)</b>	<b>47</b>
<b>10.0</b>	<b>SEQUENCE OF OPERATION</b>	<b>48</b>
10.1	Cooling	48
10.2	Heating (Electric Heat Only)	48
10.3	Heating (Heat Pump)	48
10.4	Blower Time Delay (Heating or Cooling)	48
10.5	Defrost	48
10.6	Emergency Heat	49
10.7	Room Thermostat	49
<b>11.0</b>	<b>CALCULATIONS</b>	<b>49</b>
11.1	Calculating Temperature Rise	49
11.2	Calculating BTUH Heating Capacity	49
11.3	Calculating Airflow CFM	49
11.4	Calculating Correction Factor	50
<b>12.0</b>	<b>PRE-START CHECKLIST</b>	<b>50</b>
<b>13.0</b>	<b>MAINTENANCE</b>	<b>51</b>
13.1	Air Filter	51
13.2	Indoor Coil - Drain Pan - Drain Line	51
13.3	The EcoNet™ Air Handler Control Board Replacement	51
13.4	Blower Motor and Wheel	52
13.5	Lubrication	52
13.6	Blower Assembly Removal and Replacement	52
13.7	Motor Replacement	53
13.8	ECM Control Module Replacement	54
13.9	Blower Wheel Replacement	54
<b>14.0</b>	<b>REPLACEMENT PARTS</b>	<b>54</b>
<b>15.0</b>	<b>ACCESSORIES - KITS - PARTS</b>	<b>55</b>

**⚠ WARNING** (SEE SECTION 4.0: ELECTRICAL WIRING)

Disconnect all power to unit before installing or servicing. More than one disconnect switch may be required to de-energize the equipment. Hazardous voltage can cause severe personal injury or death.

**⚠ WARNING** (SEE SECTION 12.5: BLOWER ASSEMBLY REMOVAL & REPLACEMENT)

If removal of the blower assembly is required, all disconnect switches supplying power to the equipment must be de-energized and locked (if not in sight of unit) so the field power wires can be safely removed from the blower assembly. Failure to do so can cause electrical shock resulting in personal injury or death.

**⚠ WARNING**

Because of possible damage to equipment or personal injury, installation, service, and maintenance should be performed by a trained, qualified service personnel. Consumer service is recommended only for filter cleaning/replacement. Never operate the unit with the access panels removed.

## 1.0 SAFETY INFORMATION

**⚠ WARNING**

Duct leaks can create an unbalanced system and draw pollutants such as dirt, dust, fumes and odors into the home causing property damage. Fumes and odors from toxic, volatile or flammable chemicals, as well as automobile exhaust and carbon monoxide (CO), can be drawn into the living space through leaking ducts and unbalanced duct systems causing personal injury or death (see Figure 1).

- If air-moving equipment or ductwork is located in garages or off-garage storage areas - all joints, seams, and openings in the equipment and duct must be sealed to limit the migration of toxic fumes and odors including carbon monoxide from migrating into the living space.
- If air-moving equipment or ductwork is located in spaces containing fuel burning appliances such as water heaters or boilers - all joints, seams, and openings in the equipment and duct must also be sealed to prevent depressurization of the space and possible migration of combustion byproducts including carbon monoxide into the living space.

**⚠ WARNING**

These instructions are intended as an aid to qualified, licensed service personnel for proper installation, adjustment and operation of this unit. Read these instructions thoroughly before attempting installation or operation. Failure to follow these instructions may result in improper installation, adjustment, service or maintenance possibly resulting in fire, electrical shock, property damage, personal injury or death.

**⚠ WARNING** (SEE SECTION 3.2: VERTICAL DOWNFLOW)

The RXHB-17, RXHB-21 or RXHB-24 combustible floor base is required when some units with electric heat are applied downflow on combustible flooring. Failure to use the base can cause a fire resulting in property damage, personal injury or death. See **CLEARANCES** for units requiring a combustible floor base. See the accessory section in this manual for combustible floor base RXHB.

**⚠ WARNING** (SEE SECTION 4.3: GROUNDING)

The unit must be permanently grounded. Failure to do so can result in electrical shock causing personal injury or death.

**⚠ WARNING** (SEE SECTION 12.0: MAINTENANCE)

Units with circuit breaker(s) meet requirements as a service disconnect switch, however, if access is required to the line side (covered) of the circuit breaker, this side of the breaker(s) will be energized with the breaker(s) de-energized. Contact with the line side can cause electrical shock resulting in personal injury or death.

**⚠ WARNING** (SEE SECTION 5.0: DUCTWORK)

Do not, under any circumstances, connect return ductwork to any other heat producing device such as fireplace insert, stove, etc. Unauthorized use of such devices may result in fire, carbon monoxide poisoning, explosion, personal injury or property damage.

## **WARNING**

**PROPOSITION 65:** This appliance contains fiberglass insulation. Respirable particles of fiberglass are known to the State of California to cause cancer.

All manufacturer products meet current Federal OSHA Guidelines for safety. California Proposition 65 warnings are required for certain products, which are not covered by the OSHA standards.

California's Proposition 65 requires warnings for products sold in California that contain or produce any of over 600 listed chemicals known to the State of California to cause cancer or birth defects such as fiberglass insulation, lead in brass, and combustion products from natural gas.

All "new equipment" shipped for sale in California will have labels stating that the product contains and/or produces Proposition 65 chemicals. Although we have not changed our processes, having the same label on all our products facilitates manufacturing and shipping. We cannot always know "when, or if" products will be sold in the California market.

You may receive inquiries from customers about chemicals found in, or produced by, some of our heating and air-conditioning equipment, or found in natural gas used with some of our products. Listed below are those chemicals and substances commonly associated with similar equipment in our industry and other manufacturers.

- Glass Wool (Fiberglass) Insulation
- Carbon Monoxide (CO).
- Formaldehyde
- Benzene

More details are available at the websites for OSHA (Occupational Safety and Health Administration), at [www.osha.gov](http://www.osha.gov) and the State of California's OEHHA (Office of Environmental Health Hazard Assessment), at [www.oehha.org](http://www.oehha.org). Consumer education is important since the chemicals and substances on the list are found in our daily lives. Most consumers are aware that products present safety and health risks, when improperly used, handled and maintained.

## **WARNING** (SEE SECTION 12.6: MOTOR REPLACEMENT)

To avoid electrical shock which can result in personal injury or death, use only the screws furnished in the motor shell mounting holds. Screws are #8-18 x .25 in. long blunt nose thread forming. Screws longer than 1/4 in. may contact the motor winding.

## **WARNING** (SEE SECTION 7.0: AIR FILTER)

Do not operate the system without filters. A portion of the dust entrained in the air may temporarily lodge in the duct runs and at the supply registers. Any circulated dust particles could be heated and charred by contact with the air handler elements. This residue could soil ceilings, walls, drapes, carpets and other articles in the house.

Soot damage may occur with filters in place, when certain types of candles, oil lamps or standing pilots are burned.

## **WARNING**

The first 36 inches of supply air plenum and ductwork must be constructed of sheet metal as required by NFPA 90B. The supply air plenum or duct must have a solid sheet metal bottom directly under the unit with no openings, registers or flexible air ducts located in it. If flexible supply air ducts are used they may be located only in the vertical walls of a rectangular plenum, a minimum of 6 inches from the solid bottom. Metal plenum or duct may be connected to the combustible floor base, if not, it must be connected to the unit supply duct flanges such that combustible floor or other combustible material is not exposed to the supply air opening from the downflow unit. Exposing combustible (non-metal) material to the supply opening of a downflow unit can cause a fire resulting in property damage, personal injury or death.

### Exceptions to downflow warnings:

- Installations on concrete floor slab with supply air plenum and ductwork completely encased in not less than 2 inches of concrete (See NFPA 90B).

## **CAUTION** (SEE SECTION 3.3: HORIZONTAL)

Horizontal units must be configured for right hand air supply or left hand air supply. Horizontal drain pan must be located under indoor coil. Failure to use the drain pan can result in property damage.

## **CAUTION** (SEE SECTION 2.1: RECEIVING)

In compliance with recognized codes, it is recommended that an auxiliary drain pan be installed under all evaporator coils or units containing evaporator coils that are located in any area of a structure where damage to the building or building contents may occur as a result of an overflow of the coil drain pan or a stoppage in the primary condensate drain piping. See accessories for auxiliary horizontal overflow pan RXBM.

## **NOTICE**

When used in cooling applications, excessive sweating may occur when unit is installed in an unconditioned space. This can result in property damage.

## **NOTICE**

Improper installation, or installation not made in accordance with the Underwriters Laboratory (UL) certification or these instructions, can result in unsatisfactory operation and/or dangerous conditions and are not covered by the unit warranty.

## **NOTICE**

In compliance with recognized codes, it is recommended that an auxiliary drain pan be installed under all evaporator coils or units containing evaporator coils that are located in any area of a structure where damage to the building or building contents may occur as a result of an overflow of the coil drain pan or a stoppage in the primary condensate drain piping. See accessories section of these instructions for auxiliary horizontal overflow pan information (model RXBM).

## ⚠ NOTICE

Use of this air-handler during construction is not recommended. If operation during construction is absolutely required, the following temporary installation requirements must be followed:

Installation must comply with all Installation Instructions in this manual including the following items:

- Properly sized power supply and circuit breaker/fuse
- Air-handler operating under thermostatic control;
- Return air duct sealed to the air-handler;
- Air filters must be in place;
- Correct air-flow setting for application
- Removing the coil and storing it in a clean safe place is highly recommended until construction is completed and the outdoor unit is installed.
- Clean air-handler, duct work, and components including coil upon completion of the construction process and verify proper air-handler operating conditions according as stated in this instruction manual.
- NOTE: Electric strip heater elements tend to emit a burning odor for a few days if dust has accumulated during construction. Heater elements are easily damaged. Take great care when cleaning them. Low pressure compressed air is recommended for cleaning elements.

## 2.0 GENERAL INFORMATION

### 2.1 IMPORTANT INFORMATION ABOUT EFFICIENCY AND INDOOR AIR QUALITY

Central cooling and heating equipment is only as efficient as the duct system that carries the cooled or heated air. To maintain efficiency, comfort and good indoor air quality,

**FIGURE 1**  
MIGRATION OF DANGEROUS SUBSTANCES, FUMES, AND ODORS INTO LIVING SPACES

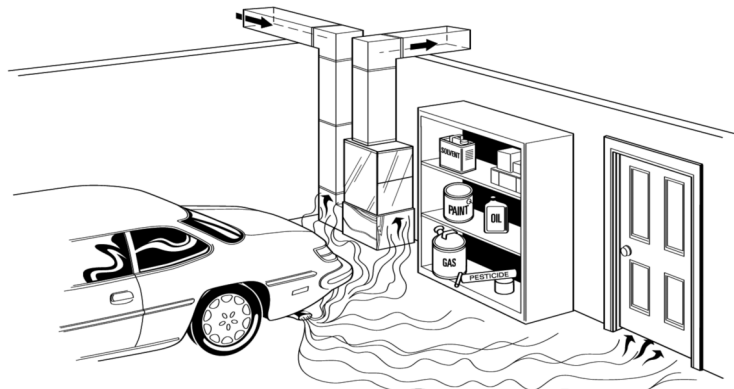

Adapted from *Residential Duct Diagnostics and Repair*, with permission of Air Conditioning Contractors of America (ACCA).

## ⚠ WARNING



### Carbon Monoxide (CO) Poisoning Can Cause Severe Injury or Death.

Carbon Monoxide from the exhaust of motor vehicles and other fuel burning devices can be drawn into the living space by the operation of the central heating and air conditioning system.

Exhaust from motor vehicles, generators, garden tractors, mowers, portable heaters, charcoal and gas grills, gasoline powered tools, and outdoor camping equipment contains carbon monoxide, a poisonous gas that can kill you. You cannot see it, smell it, or taste it.

- Do NOT operate an automobile or any engine in a garage for more than the few seconds it takes to enter or exit the garage.
- Do NOT operate any fuel-burning device in an enclosed or partly enclosed space, or near building windows, doors or air intakes.

The U.S. Consumer Product Safety Commission (CPSC) and Health Canada recommend the installation of UL or CSA certified Carbon Monoxide Alarm(s) in every home.

## ⚠ WARNING

Duct leaks can create an unbalanced system and draw pollutants such as dirt, dust, fumes and odors into the home causing property damage. Fumes and odors from toxic, volatile or flammable chemicals, as well as automobile exhaust and carbon monoxide (CO), can be drawn into the living space through leaking ducts and unbalanced duct systems causing personal injury or death (see Figure 1).

- If air-moving equipment or ductwork is located in garages or off-garage storage areas - all joints, seams, and openings in the equipment and duct must be sealed to limit the migration of toxic fumes and odors including carbon monoxide from migrating into the living space.
- If air-moving equipment or ductwork is located in spaces containing fuel burning appliances such as water heaters or boilers - all joints, seams, and openings in the equipment and duct must also be sealed to prevent depressurization of the space and possible migration of combustion byproducts including carbon monoxide into the living space.

## ⚠ NOTICE

Improper installation, or installation not made in accordance with the Underwriters Laboratory (UL) certification or these instructions, can result in unsatisfactory operation and/or dangerous conditions and are not covered by the unit warranty.

it is important to have the proper balance between the air being supplied to each room and the air returning to the cooling and heating equipment.

Proper balance and sealing of the duct system improves the efficiency of the heating and air conditioning system and improves the indoor air quality of the home by reducing the amount of airborne pollutants that enter homes from spaces where the ductwork and/or equipment is located. The manufacturer and the U.S. Environmental Protection Agency's Energy Star Program recommend that central duct systems be checked by a qualified contractor for proper balance and sealing.

## NOTICE

**In compliance with recognized codes, it is recommended that an auxiliary drain pan be installed under all evaporator coils or units containing evaporator coils that are located in any area of a structure where damage to the building or building contents may occur as a result of an overflow of the coil drain pan or a stoppage in the primary condensate drain piping. See accessories section of these instructions for auxiliary horizontal overflow pan information (model RXBM).**

## 2.2 RECEIVING

Immediately upon receipt, all cartons and contents should be inspected for transit damage. Units with damaged cartons should be opened immediately. If damage is found, it should be noted on the delivery papers, and a damage claim filed with the last carrier.

- After unit has been delivered to job site, remove carton taking care not to damage unit.
- Check the unit rating plate for unit size, electric heat, coil, voltage, phase, etc. to be sure equipment matches what is required for the job specification.
- Read the entire instructions before starting the installation.
- Some building codes require extra cabinet insulation and gasketing when unit is installed in attic applications.
- If installed in an unconditioned space, apply caulking around the power wires, control wires, refrigerant tubing and condensate line where they enter the cabinet. Seal the power wires on the inside where they exit conduit opening. Caulking is required to pre-vent air leakage into and condensate from forming inside the unit, control box, and on electrical controls.
- Install the unit in such a way as to allow necessary access to the coil/filter rack and blower/control compartment.
- Install the unit in a level position to ensure proper condensate drainage. Make sure unit is level in both directions within 1/8".
- Install the unit in accordance with any local code which may apply and the national codes. Latest editions are available from: "National Fire Protection Association, Inc., Batterymarch Park, Quincy, MA 02269." These publications are:
  - ANSI/NFPA No. 70-(Latest Edition) National Electrical Code.
  - NFPA90A Installation of Air Conditioning and Ventilating Systems.
  - NFPA90B Installation of warm air heating and air conditioning systems.
- The equipment has been evaluated in accordance with the Code of Federal Regulations, Chapter XX, Part 3280.

## 2.3 CLEARANCES

- All units are designed for "0" inches clearance to combustible material on all cabinet surfaces.
- Units with electric heat require a one inch clearance to combustible material for the first three feet of supply plenum and ductwork.
- Some units require a combustible floor base depending on the heating kW. The following table should be used to determine these requirements.

Model Cabinet Size	17	21	24
Maximum Model Designation kW	15	18	20

**Additionally, if these units are installed down-flow, a combustible floor base is required. See Accessories for Combustible Floor Base RXHB-XX.**

Units with electric heating kW equal to or less than the values listed in the table do not require a combustible floor base.

- Vertical units require clearance on at least one side of the unit for electrical connections. Horizontal units require clearance on either top or bottom for electrical connections. Refrigerant and condensate drain connections are made on the front of the unit.
- All units require 24 inches minimum access to the front of the unit for service.
- These units may be installed in either ventilated or nonventilated spaces.

## 2.4 MODEL NUMBER EXPLANATION

**FIGURE 2**  
MODEL NUMBER EXPLANATION

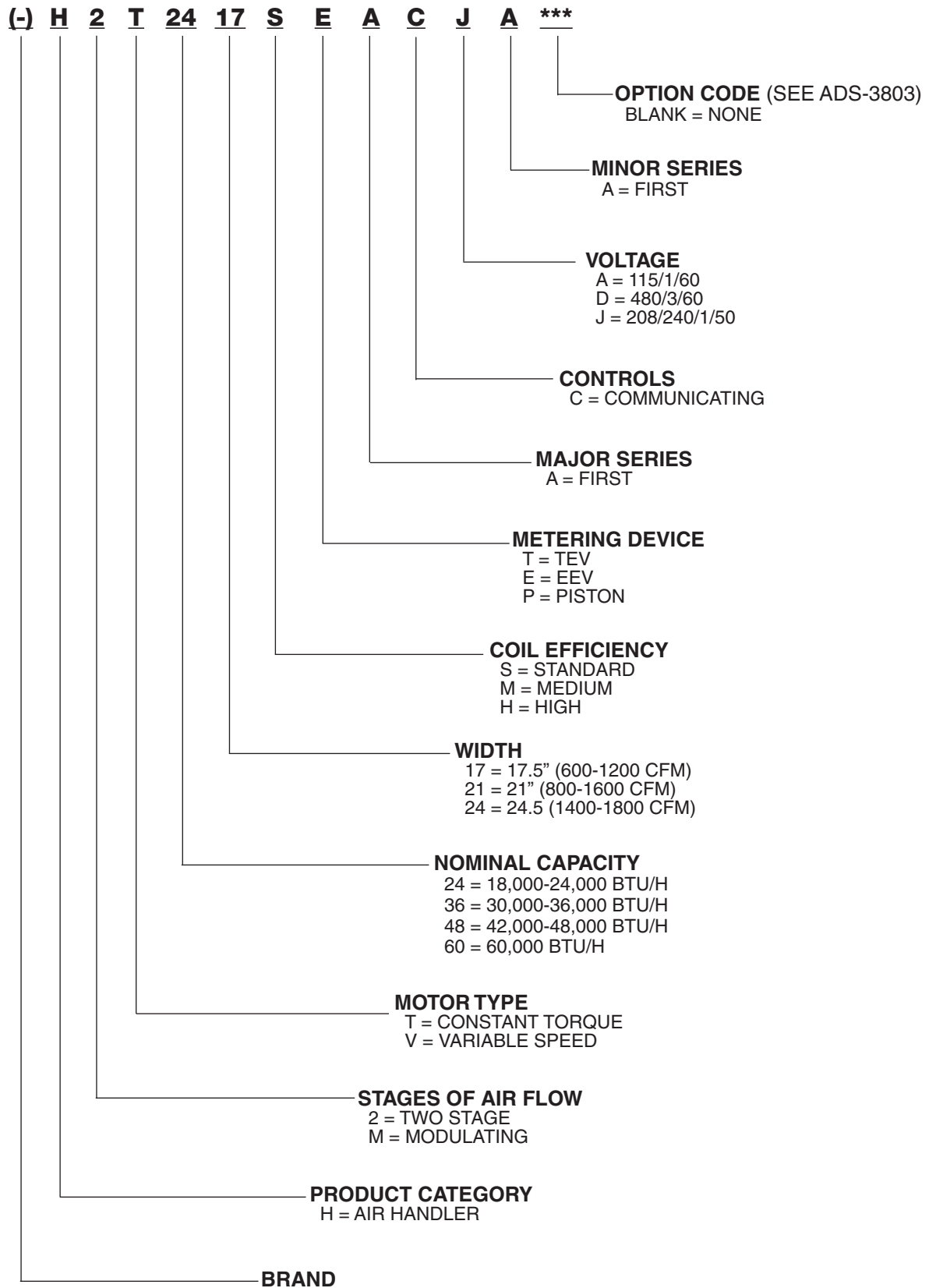

## 2.4A AVAILABLE MODELS

### AVAILABLE MODELS AT J VOLTAGE

(-)H2T2417SEACJA
(-)H2T2421MEACJA
(-)H2T3617SEACJA
(-)H2T3621MEACJA
(-)H2T4821MEACJA
(-)H2T6021SEACJA
(-)H2T6024MEACJA
(-)H2MV2417SEACJA
(-)H2MV2421MEACJA
(-)H2MV2421HEACJA
(-)H2MV3617SEACJA
(-)H2MV6021SEACJA
(-)H2MV6024SEACJA

#### Notes:

- Supply circuit protective devices may be fuses or “HACR” type circuit breakers.
- Largest motor load is included in single circuit and multiple circuit 1.
- If non-standard fuse size is specified, use next size larger fuse size.
- The air handlers are shipped from the factory with the proper indoor coil installed, and cannot be ordered without a coil.
- The air handlers do not have an internal filter rack. An external filter rack or other means of filtration is required.



## 2.5 DIMENSIONS & WEIGHTS

**FIGURE 3**  
DIMENSIONS AND WEIGHTS

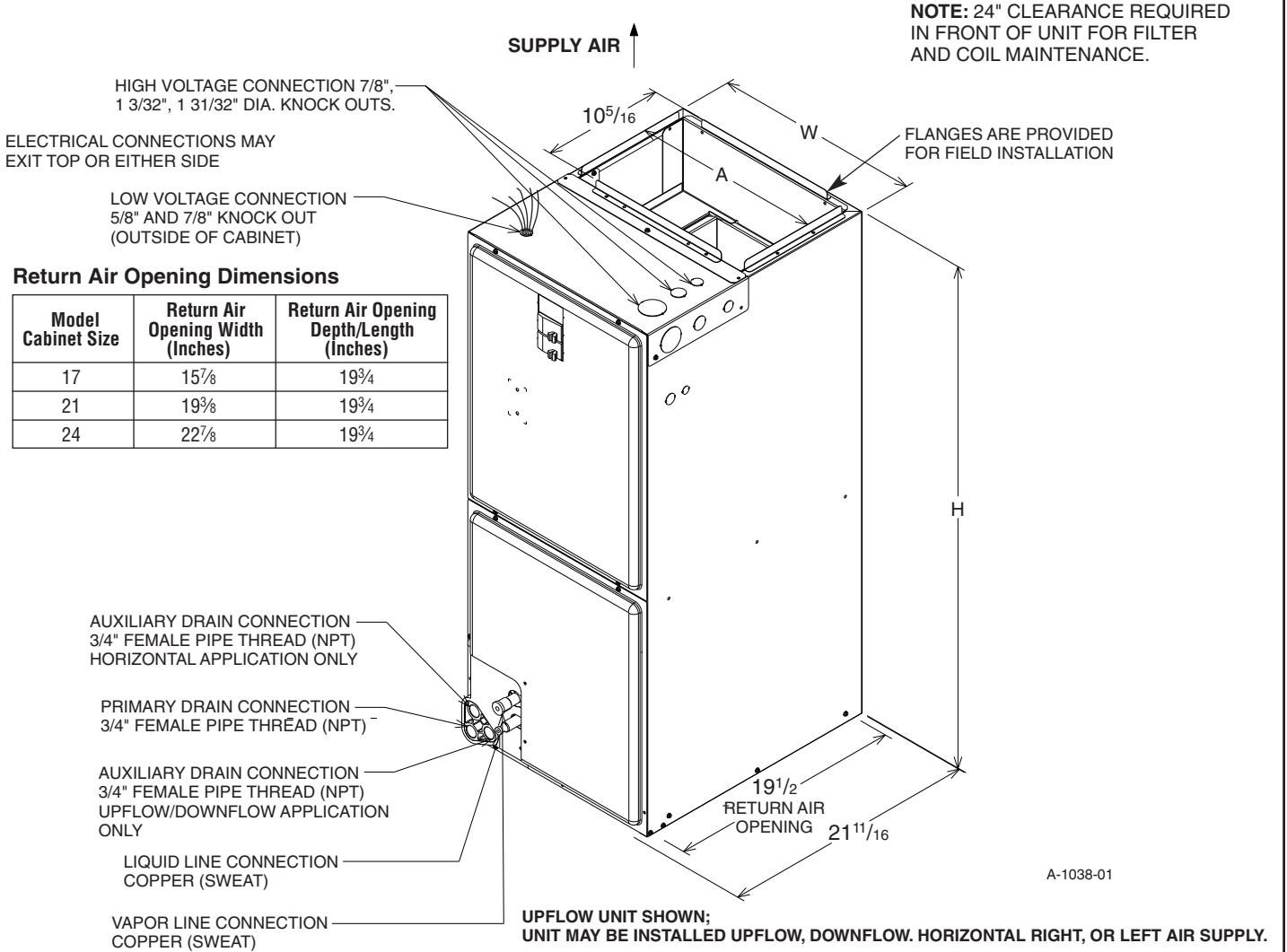

A-1038-01

### DIMENSIONAL DATA

MODEL SIZE (-)H2T	REFRIGERANT CONNECTIONS		UNIT HEIGHT IN. [mm]	UNIT WIDTH "W" IN. [mm]	SUPPLY DUCT "A" IN. [mm]	AIRFLOW COIL (NOM.) [L/s]			UNIT WEIGHT / SHIPPING WEIGHT (LBS.) [kg]
	SWEAT (IN.) [MM] ID					FAN	LO	HI	UNIT WITH COIL (MAX. kW.)
	LIQUID	VAPOR							
2417SE	3/8" [9.53]	3/4" [19.05]	42 1/2" [1080]	17 1/2" [444.5]	16" [406.4]	535	535	750	92/106 [42/48]
2421ME	3/8" [9.53]	3/4" [19.05]	42 1/2" [1080]	21" [533.4]	19 1/2" [495.3]	535	535	720	111/126 [50/57]
3617SE	3/8" [9.53]	3/4" [19.05]	42 1/2" [1080]	17 1/2" [444.5]	16" [406.4]	670	670	1230	96/110 [44/50]
3621ME	3/8" [9.53]	3/4" [19.05]	50 1/2" [1283]	21" [533.4]	19 1/2" [495.3]	800	800	1088	129/145 [59/66]
4821ME	3/8" [9.53]	7/8" [22.23]	57" [1448]	21" [533.4]	19 1/2" [495.3]	890	1050	1430	141/153 [64/69]
6021SE	3/8" [9.53]	7/8" [22.23]	57" [1448]	21" [533.4]	19 1/2" [495.3]	900	1200	1600	141/153 [64/69]
6024ME	3/8" [9.53]	7/8" [22.23]	55 1/2" [1410]	24 1/2" [622.3]	23" [584]	1200	1200	1600	161/178 [73/81]

MODEL SIZE (-)HMV	REFRIGERANT CONNECTIONS		UNIT HEIGHT IN. [mm]	UNIT WIDTH "W" IN. [mm]	SUPPLY DUCT "A" IN. [mm]	AIRFLOW COIL (NOM.) [L/s]			UNIT WEIGHT / SHIPPING WEIGHT (LBS.) [kg]
	SWEAT (IN.) [MM] ID					FAN	LO	HI	UNIT WITH COIL (MAX. kW.)
	LIQUID	VAPOR							
2417SE	3/8" [9.53]	3/4" [19.05]	42 1/2" [1080]	17 1/2" [444.5]	16" [406.4]	550	550	750	92/106 [42/48]
2421ME	3/8" [9.53]	3/4" [19.05]	42 1/2" [1080]	21" [533.4]	19 1/2" [495.3]	310	460	835	111/126 [50/57]
2421HE	3/8" [9.53]	7/8" [22.23]	50 1/2" [1283]	21" [533.4]	19 1/2" [495.3]	325	580	850	130/146 [59/66]
3617SE	3/8" [9.53]	3/4" [19.05]	42 1/2" [1080]	17 1/2" [444.5]	16" [406.4]	660	660	1235	96/110 [44/50]
6021SE	3/8" [9.53]	7/8" [22.23]	57" [1448]	21" [533.4]	19 1/2" [495.3]	480	830	1565	141/153 [64/69]
6024ME	3/8" [9.53]	7/8" [22.23]	55 1/2" [1410]	24 1/2" [622.3]	23" [584]	555	890	1665	161/178 [73/81]

## 3.0 APPLICATIONS

### 3.1 VERTICAL UPFLOW AND HORIZONTAL LEFT

- Vertical Upflow is the factory configuration for all models (see Figure 3).
- If a side return air opening is required, field fabricate a return air plenum with an opening large enough to supply unit and strong enough to support unit weight.
- If return air is to be ducted, install duct flush with floor. Use fireproof resilient gasket 1/8 to 1/4 in. thick between duct, unit and floor. Set unit on floor over opening.
- Support along the length of the unit, all units installed horizontally. Do not support or suspend unit from both ends without support in the center of the cabinet. If unit is to be supported or suspended from corners, run two reinforcing rails length of unit and support or suspend from reinforcing rails.
- Secondary drain pan kits RXBM- are required when the unit is configured for the horizontal left position over a finished ceiling and/or living space. (See Section 15.0: Accessories - Kits - Parts.)

**FIGURE 4**  
DIMENSIONS FOR FRONT CONNECT COIL

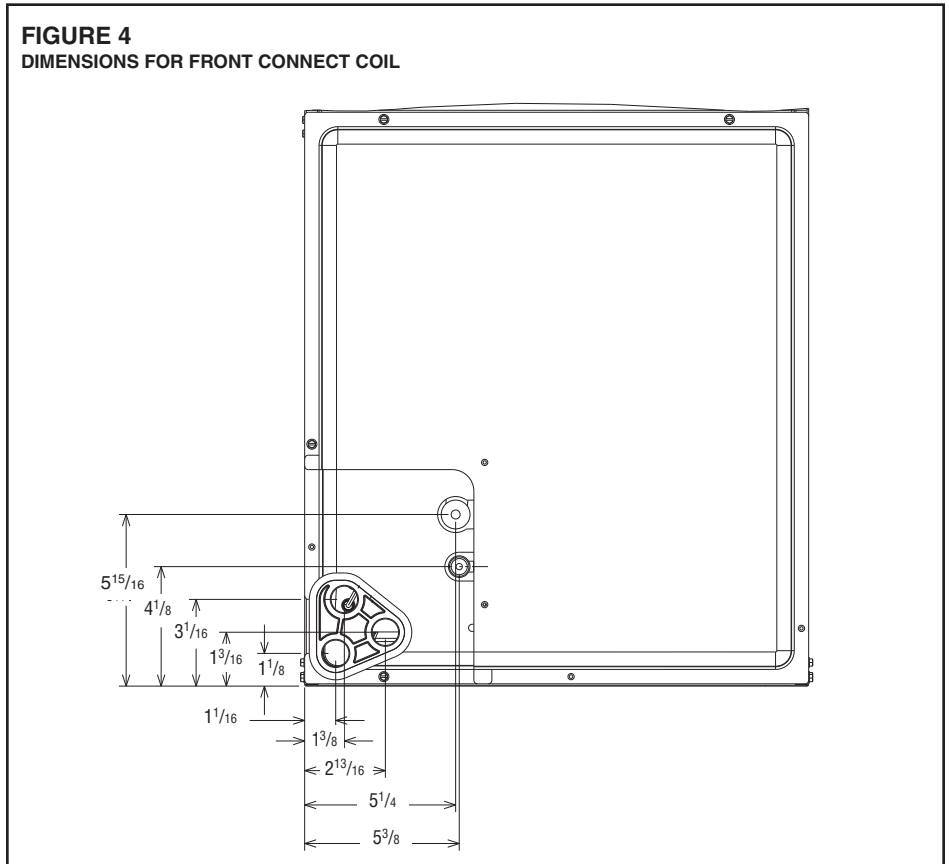

### 3.2 VERTICAL DOWNFLOW AND HORIZONTAL RIGHT

**Conversion to Vertical Downflow:** A vertical upflow unit may be converted to vertical downflow. Remove the door and indoor coil and reinstall 180° from original position (see Figure 6). (See kit model number on page 46.)

**IMPORTANT:** To comply with certification agencies and the National Electric Code for horizontal right application, the circuit breaker(s) on field-installed electric heater kits must be re-installed per procedure below so that the breaker switch “on” position and marking is up and, “off” position and marking is down.

- To turn breaker(s): Rotate one breaker pair (circuit) at a time starting with the one on the right. Loosen both lugs on the load side of the breaker. Wires are bundles with wire ties, one bundle going to the right lug and one bundle going to the left lug.
- Using a screwdriver or pencil, lift white plastic tab with hole away from breaker until breaker releases from mounting opening (see Figure 5).
- With breaker held in hand, rotate breaker so that “on” position is up, “off” position is down with unit in planned vertical mounting position. Insert right wire bundle into top right breaker lug, ensuring all strands of all wires are inserted fully into lug, and no wire insulation is in lug.
- Tighten lug as tight as possible while holding circuit breaker. Check wires and make sure each wire is secure and none are loose. Repeat for left wire bundle in left top circuit breaker lug.

**FIGURE 5**  
**ROTATING CIRCUIT BREAKER**

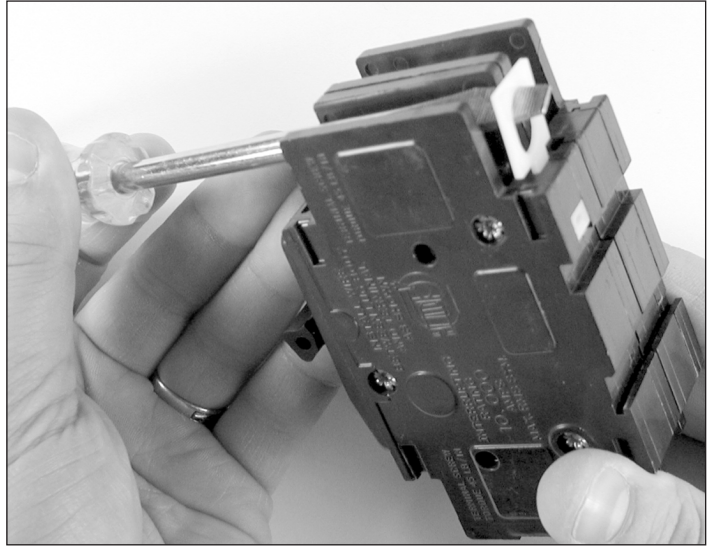

- Replace breaker by inserting breaker mounting tab opposite white pull tab in opening, hook mounting tab over edge in opening.
- With screwdriver or pencil, pull white tab with hole away from breaker while setting that side of breaker into opening. When breaker is in place, release tab, locking circuit breaker into location in opening.
- Repeat above operation for remaining breaker(s) (if more than one is provided).
- Replace single point wiring jumper bar, if it is used, on line side of breaker and tighten securely.
- Double check wires and lugs to make sure all are secure and tight. Check to make sure unit wiring to circuit breaker load lugs match that shown on the unit wiring diagram.
- RXHB combustible floor base is used for all unit sizes. Unit must be centered on combustible base in the width dimension (14<sup>3/8</sup>”). (See Section 14.0 for more information on the combustible floor base.)

**DRIP LOOP:** When installing the unit in down-flow or horizontal-right positions, make sure that the wires coming from the motor form a proper drip loop. This allows water to cascade off the lowest point of the wiring before it enters the motor head. This may require cutting the wire tie and installing a new wire tie to form this loop.

### **WARNING**

**The RXHB-17, RXHB-21 or RXHB-24 combustible floor base is required when some units with electric heat are applied downflow on combustible flooring. Failure to use the base can cause a fire resulting in property damage, personal injury or death. See CLEARANCES for units requiring a combustible floor base. See the accessory section in this manual for combustible floor base RXHB.**

- Rotate unit into the downflow position, with the coil compartment on top and the blower compartment on bottom.
- The set of coil rails must be moved for vertical down-flow and horizontal right application. Remove the coil rail from the factory configuration (6 screws in all). Fastener clearance holes will need to be drilled in the cabinet sides (proper hole locations are marked with “dimples” for this purpose). Note that the shorter (no notch) coil rail must be mounted on the left-hand side to provide clearance for the drain pan condensate connection boss.
- Reinstall the indoor coil 180° from original position. Ensure the retaining channel is fully engaged with the coil rail. (See Figure 6, Detail A.)
- Secondary drain pan kits RXBM- are required when the unit is configured for the horizontal right position over a finished ceiling and/or living space. (See Section 14.0: Accessories - Kits - Parts.)

**IMPORTANT:** Units cannot be installed horizontally laying on or suspended from the back of the unit.

**FIGURE 6**  
VERTICAL DOWNFLOW & HORIZONTAL RIGHT APPLICATION

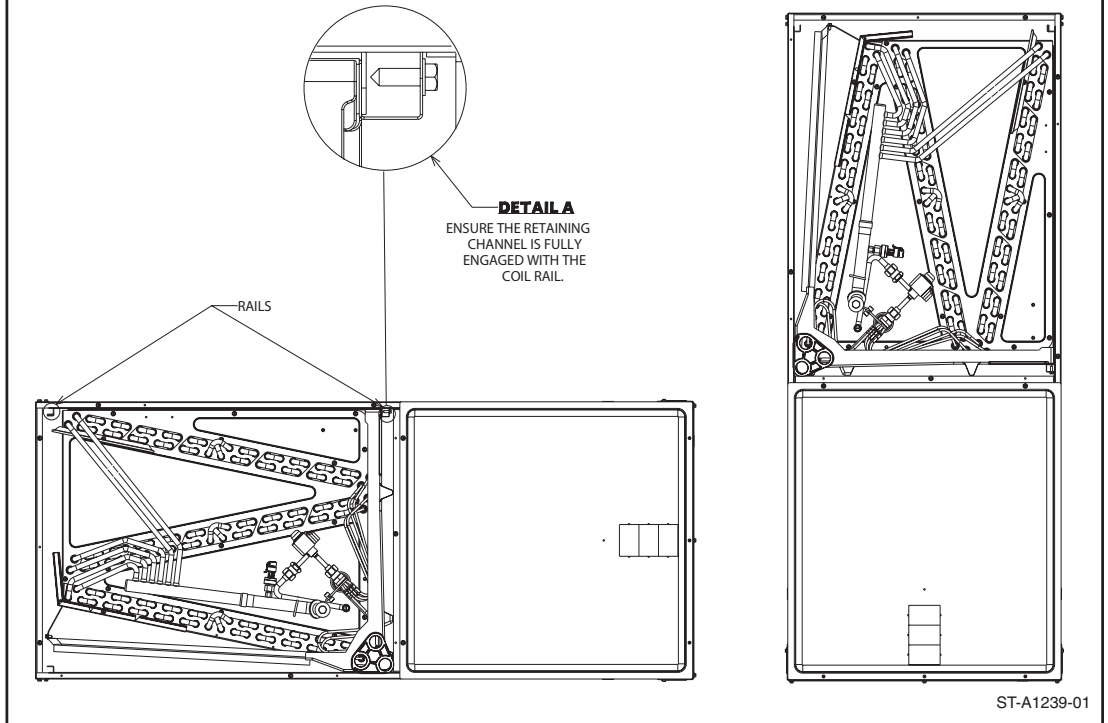

**FIGURE 7**  
INDOOR COIL AND DRAIN PAN SET-UP

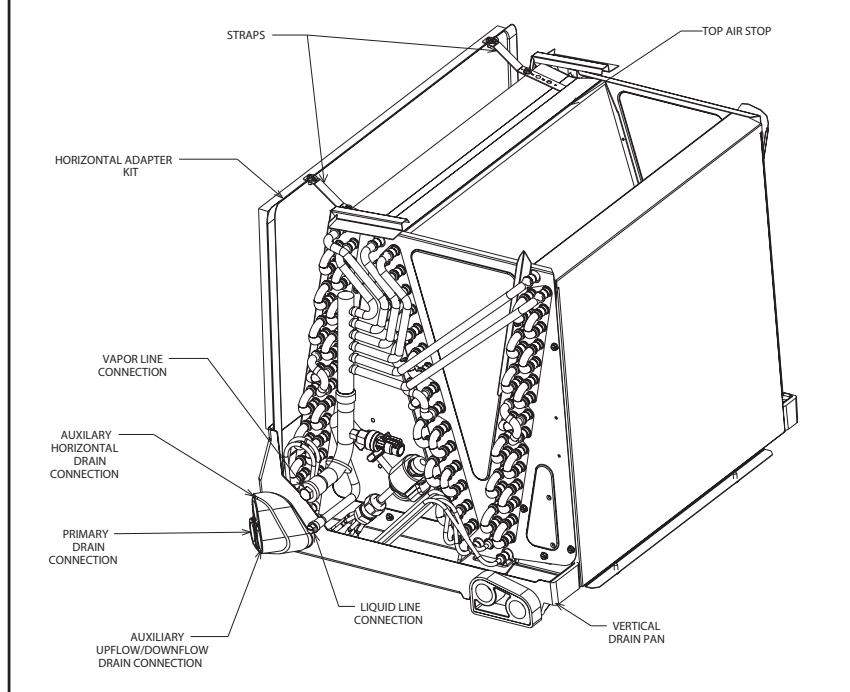

**CAUTION**

Horizontal units must be configured for right hand air supply or left hand air supply. Horizontal drain pan must be located under indoor coil. Failure to use the drain pan can result in property damage.

**Conversion in Horizontal Direction:** Horizontal left-hand supply can be changed to horizontal right-hand supply by removing the indoor coil and reinstalling 180° from original. (See Figure 6.)

**3.3 INSTALLATION IN AN UNCONDITIONED SPACE**

The exterior cabinet of an air handler has a greater risk of sweating when installed in an unconditioned space than when it is installed in the conditioned space. This is primarily

due to the temperature of the conditioned air moving through the air handler and the air circulating around the unit where it is installed. For this reason, we recommend the following for all air handler applications, but special attention should be paid to those installed in unconditioned spaces:

- Duct sizing and airflow are critical and based on the equipment selected
- Supply and return duct attachment: If other than the factory flanges are used, the attachment of ducting must be insulated and tight to prevent sweating.
- No perimeter supply flanges are provided. If a full perimeter supply duct is used, it is the responsibility of the installer to provide duct flanges as needed, to secure and seal the supply duct to prevent air leakage and the sweating that will result.
- All wire penetrations should be sealed. Take care not to damage, remove or compress insulation in those cases.
- In some cases, the entire air handler can be wrapped with insulation. This can be done as long as the unit is completely enclosed in insulation, sealed and service access is provided to prevent accumulation of moisture inside the insulation.
- As required, use a secondary pan that will protect the structure from excessive sweating or a restricted coil drain line.
- If a heater kit is installed, be sure the breaker or disconnect cover is sealed tightly to the door panel.

### 3.4 INSTALLATION IN MOBILE/MANUFACTURED HOMES

1. Air handler must be secured to the structure using "L" brackets or pipe strap.
2. Allow a minimum of 24 inches (610 mm) front clearance required to access doors.
3. Recommended method for securing air handler:
  - A. If air handler is against the wall, secure top of air handler to wall stud using two 16ga thick angle brackets one on each side. Attach brackets with No. 10 self-tapping  $\frac{1}{2}$ " long screws to air handler and use  $\frac{5}{16}$ " lag screws  $1\frac{1}{2}$ " long to wall stud. Secure bottom of unit with two 16ga "L" brackets with No. 10 self-tapping  $\frac{1}{2}$ " long screws to air handler and use  $\frac{5}{16}$ " lag screws  $1\frac{1}{2}$ " long to floor.
  - B. If air handler is away from wall attach pipe strap to top of air handler using No. 10  $\frac{1}{2}$ " long self-tapping screws on both sides. Angle strap down and away from back of air handler, remove all slack, and fasten to wall stud of structure using  $\frac{5}{16}$ " lag screws  $1\frac{1}{2}$ " long. Secure bottom of unit with two 16ga "L" brackets with No. 10 self-tapping screws to air handler and use  $\frac{5}{16}$ " lag screws  $1\frac{1}{2}$ " long to floor.

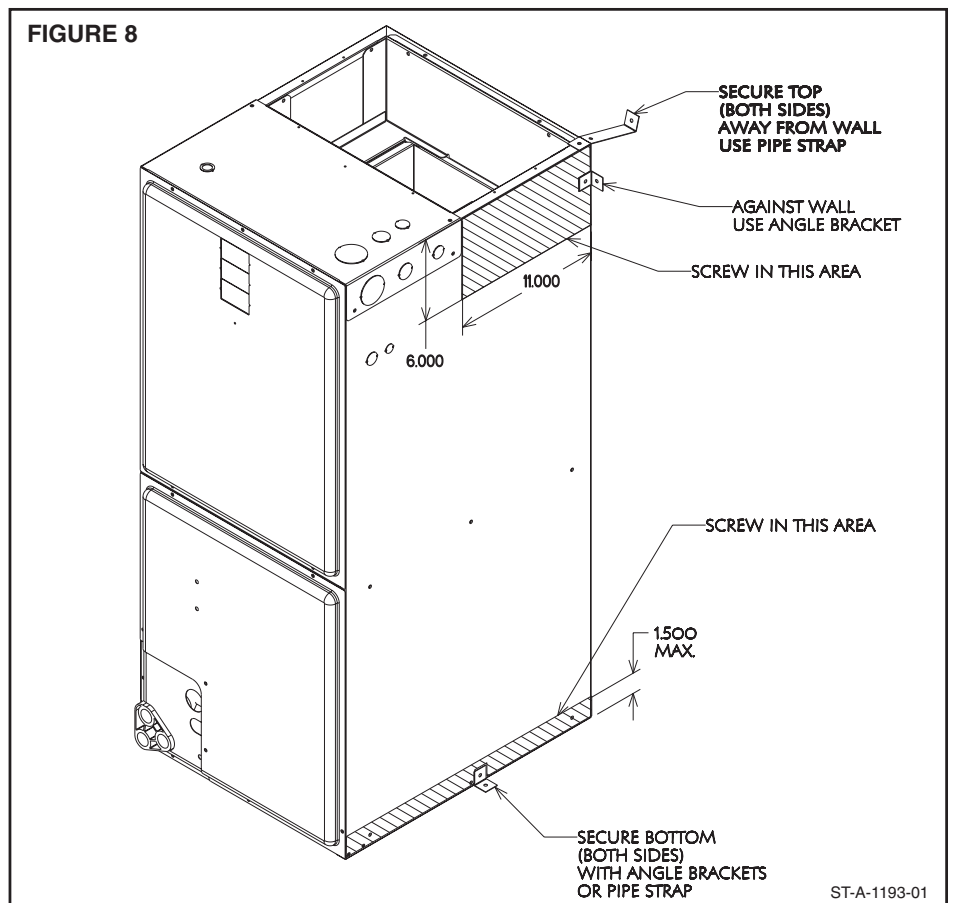

## 4.0 ELECTRICAL WIRING

Field wiring must comply with the National Electric Code (C.E.C. in Canada) and any applicable local ordinance.

### **WARNING**

**Disconnect all power to unit before installing or servicing. More than one disconnect switch may be required to de-energize the equipment. Hazardous voltage can cause severe personal injury or death.**

### 4.1 POWER WIRING

It is important that proper electrical power is available for connection to the unit model being installed. See the unit nameplate, wiring diagram and electrical data in the installation instructions.

- If required, install a branch circuit disconnect of adequate size, located within sight of, and readily accessible to the unit.
- **IMPORTANT:** After the Electric Heater is installed, units may be equipped with one, two, or three 30/60 amp. circuit breakers. These breaker(s) protect the internal wiring in the event of a short circuit and serve as a disconnect. Circuit breakers installed within the unit do not provide over-current protection of the supply wiring and therefore may be sized larger than the branch circuit protection.
- Supply circuit power wiring must be 75°C minimum copper conductors only. See Electrical Data in this section for ampacity, wire size and circuit protector requirement. Supply circuit protective devices may be either fuses or “HACR” type circuit breakers.
- Power wiring may be connected to either the right, left side or top. Three  $\frac{7}{8}$ ”,  $1\frac{3}{32}$ ”,  $1\frac{31}{32}$ ” dia. concentric knockouts are provided for connection of power wiring to unit.
- Power wiring is connected to the power terminal block in unit control compartment.

### 4.2 GROUNDING

### **WARNING**

**The unit must be permanently grounded. Failure to do so can result in electrical shock causing personal injury or death.**

- Grounding may be accomplished by grounding metal conduit when installed in accordance with electrical codes to the unit cabinet.
- Grounding may also be accomplished by attaching ground wire(s) to ground lug(s) provided in the unit wiring compartment.
- Ground lug(s) are located close to wire entrance on left side of unit (upflow). Lug(s) may be moved to marked locations near wire entrance on right side of unit (upflow), if alternate location is more convenient.
- Use of multiple supply circuits require grounding of each circuit to lug(s) provided in unit.

### 4.3 ELECTRICAL WIRING

#### POWER WIRING

- Field wiring must comply with the National Electrical Code (C.E.C. in Canada) and any applicable local ordinance.
- Supply wiring must be 75°C minimum copper conductors only.
- See electrical data for product Ampacity rating and Circuit Protector requirement.

#### GROUNDING

- This product must be sufficiently grounded in accordance with National Electrical Code (C.E.C. in Canada) and any applicable local ordinance.
- A grounding lug is provided.

#### 4.4 ELECTRICAL DATA – BLOWER MOTOR ONLY – NO ELECTRIC HEAT

##### 4.4A Electrical Data – Blower Motor Only – No Electric Heat – (-)H2T

MODEL (-)H2T	VOLTAGE	PHASE*	HERTZ	HP	RPM	SPEEDS	CIRCUIT AMPS.	MINIMUM CIRCUIT AMPACITY	MAXIMUM CIRCUIT PROTECTOR
2417SE	208/240	1	60	1/3	300-1300	2	1.6	2.0	15
2421ME		1		1/3		2	1.6	2.0	15
3617SE		1		1/2		2	2.7	4.0	15
3621ME		1		3/4		2	3.8	5.0	15
4821ME		1		3/4		2	3.8	5.0	15
6024ME		1		3/4		2	3.8	5.0	15

\*Blower motors are all single phase motors.

##### 4.4B Electrical Data – Blower Motor Only – No Electric Heat – (-)HMV

MODEL (-)HMV	VOLTAGE	PHASE*	HERTZ	HP	RPM	CIRCUIT AMPS.	MINIMUM CIRCUIT AMPACITY	MAXIMUM CIRCUIT PROTECTOR
2417SE	208/240	1	60	1/3	300-1100	2.7	4.0	15
2421ME		1		1/3		1.7	4.0	15
2421HE		1		1/2		4.3	6.0	15
3617SE		1		1/2		3.4	4.0	15
6021SE		1		3/4		4.9	9.0	15
6024ME		1		3/4		4.9	9.0	15

\*Blower motors are all single phase motors.

#### 4.5 COPPER WIRE SIZE - AWG. (3% VOLTAGE DROP)

SUPPLY WIRE	LENGTH	200 [61]	12	10	8	8	8	6	6	6	4	4	3	3	2	2	1	0	00	
		150 [46]	12	10	10	10	8	8	8	6	6	6	4	4	3	3	2	1	0	00
		100 [30]	14	12	10	10	8	8	8	6	6	4	4	3	3	2	1	0	00	
		50 [15]	14	12	10	10	8	8	8	6	6	4	4	3	3	2	1	0	00	
			15	20	25	30	35	40	45	50	60	70	80	90	100	110	125	150	175	
SUPPLY CIRCUIT AMPACITY NOTE: WIRE BASED ON COPPER CONDUCTORS 75°C MINIMUM RATING. FOR MORE THAN 3 CONDUCTORS IN A RACEWAY OR CABLE, SEE N.E.C. FOR DERATING THE AMPACITY OF EACH CONDUCTOR.																				

## 4.6A ELECTRIC HEAT ELECTRICAL DATA (-)H2T

Installation of the UL Listed original equipment manufacturer provided heater kits listed in the following table is recommended for all auxiliary heating requirements.

### HIGH KW ELECTRIC HEAT ELECTRICAL DATA: (-)H2T

AIR-HANDLER MODEL (-)H2T	HEATER MODEL NO.	HEATER KW 208/240V	PH/HZ	NO. ELEMENTS - KW PER	TYPE SUPPLY CIRCUIT SINGLE CIRCUIT MULTIPLE CIRCUIT	CIRCUIT AMPS.	MOTOR AMPACITY	MINIMUM CIRCUIT AMPACITY	MAXIMUM CIRCUIT PROTECTION
2421MT	RXBH-1724?05J	3.6/4.8	1/60	1-4.8	SINGLE	17.3/20.0	1.6	24/27	25/30
	RXBH-1724?07J	5.4/7.2	1/60	2-3.6	SINGLE	26.0/30.0	1.6	35/40	35/40
	RXBH-1724?10J	7.2/9.6	1/60	2-4.8	SINGLE	34.6/40.0	1.6	46/52	50/60
	RXBH-1724A13J	9.4/12.5	1/60	3-4.17	SINGLE	45.1/52.1	1.6	59/68	60/70
	RXBH-1724A13J	3.1/4.2	1/60	1-4.17	MULTIPLE CKT 1	15.0/17.4	1.6	21/24	25/25
		6.3/8.3	1/60	2-4.17	MULTIPLE CKT 2	30.1/34.7	0	38/44	40/45
	RXBH-1724A07C	5.4/7.2	3/60	3-2.4	SINGLE	15.0/17.3	1.6	21/24	25/25
	RXBH-1724A10C	7.2/9.6	3/60	3-3.2	SINGLE	20.0/23.1	1.6	27/31	30/35
RXBH-1724A13C	9.4/12.5	3/60	3-4.17	SINGLE	26.1/30.1	1.6	35/40	35/40	
2417SE	RXBH-17?03J	2.25/3.0	1/60	1-3.0	SINGLE	10.8/12.5	2.2	17/19	20/20
	RXBH-1724?05J	3.6/4.8	1/60	1-4.8	SINGLE	17.3/20.0	2.2	25/28	25/30
	RXBH-1724?07J	5.4/7.2	1/60	2-3.6	SINGLE	26.0/30.0	2.2	36/41	40/45
	RXBH-1724?10J	7.2/9.6	1/60	2-4.8	SINGLE	34.6/40.0	2.2	46/53	50/60
	RXBH-1724A13J	9.4/12.5	1/60	3-4.17	SINGLE	45.1/52.1	2.2	60/68	60/70
		3.1/4.2	1/60	1-4.17	MULTIPLE CKT 1	15.0/17.4	2.2	22/25	25/25
		6.3/8.3	1/60	2-4.17	MULTIPLE CKT 2	30.1/34.7	0	38/44	40/45
	RXBH-1724A07C	5.4/7.2	3/60	3-2.4	SINGLE	15.0/17.3	2.2	22/25	25/25
RXBH-1724A10C	7.2/9.6	3/60	3-3.2	SINGLE	20.0/23.1	2.2	28/32	30/35	
RXBH-1724A13C	9.4/12.5	3/60	3-4.17	SINGLE	26.1/30.1	2.2	36/41	40/45	
3617SE	RXBH-17?03J	2.25/3.0	1/60	1-3.0	SINGLE	10.8/12.5	3.1	18/20	20/20
	RXBH-1724?05J	3.6/4.8	1/60	1-4.8	SINGLE	17.3/20.0	3.1	26/29	30/30
	RXBH-1724?07J	5.4/7.2	1/60	2-3.6	SINGLE	26.0/30.0	3.1	37/42	40/45
	RXBH-1724?10J	7.2/9.6	1/60	2-4.8	SINGLE	34.6/40.0	3.1	48/54	50/60
	RXBH-1724A13J	9.4/12.5	1/60	3-4.17	SINGLE	45.1/52.1	3.1	61/69	70/70
		3.1/4.2	1/60	1-4.17	MULTIPLE CKT 1	15.0/17.4	3.1	23/26	25/30
		6.3/8.3	1/60	2-4.17	MULTIPLE CKT 2	30.1/34.7	0	38/44	40/45
	RXBH-1724A15J	10.8/14.4	1/60	3-4.8	SINGLE	51.9/60.0	3.1	69/79	70/80
		3.6/4.8	1/60	1-4.8	MULTIPLE CKT 1	17.3/20.0	3.1	26/29	30/30
		7.2/9.6	1/60	2-4.8	MULTIPLE CKT 2	34.6/40.0	0	44/50	45/50
	RXBH-1724A18J	12.8/17.0	1/60	3-5.68	SINGLE	61.6/70.8	3.1	81/93	90/100
		4.3/5.7	1/60	1-5.68	MULTIPLE CKT 1	20.5/23.6	3.1	30/34	30/35
		8.5/11.3	1/60	2-5.68	MULTIPLE CKT 2	41.1/47.2	0	52/59	60/60
	RXBH-1724A07C	5.4/7.2	3/60	3-2.4	SINGLE	15.0/17.3	3.1	23/26	25/30
	RXBH-1724A10C	7.2/9.6	3/60	3-3.2	SINGLE	20.0/23.1	3.1	29/33	30/35
	RXBH-1724A13C	9.4/12.5	3/60	3-4.17	SINGLE	26.1/30.1	3.1	37/42	40/45
RXBH-1724A15C	10.8/14.4	3/60	3-4.8	SINGLE	30.0/34.6	3.1	42/48	45/50	
RXBH-1724A18C	12.8/17.0	3/60	3-5.68	SINGLE	35.5/41.0	3.1	49/56	50/60	
3621MT	RXBH-1724?05J	3.6/4.8	1/60	1-4.8	SINGLE	17.3/20.0	3.8	27/30	30/30
	RXBH-1724?07J	5.4/7.2	1/60	2-3.6	SINGLE	26.0/30.0	3.8	38/43	40/45
	RXBH-1724?10J	7.2/9.6	1/60	2-4.8	SINGLE	34.6/40.0	3.8	48/55	50/60
	RXBH-1724A15J	10.8/14.4	1/60	3-4.8	SINGLE	51.9/60.0	3.8	70/80	70/80
	RXBH-1724A15J	3.6/4.8	1/60	1-4.8	MULTIPLE CKT1	17.3/20.0	3.8	27/30	30/30
		7.2/9.6	1/60	2-4.8	MULTIPLE CKT 2	34.6/40.0	0.0	44/50	45/50
	RXBH-1724A18J	12.8/17.0	1/60	4-4.26	SINGLE	61.6/70.8	3.8	82/94	90/100
	RXBH-1724A18J	6.4/8.5	1/60	2-4.26	MULTIPLE CKT 1	30.8/35.4	3.8	44/49	45/50
		6.4/8.5	1/60	2-4.26	MULTIPLE CKT 2	30.8/35.4	0.0	39/45	40/45
	RXBH-1724A07C	5.4/7.2	3/60	3-2.4	SINGLE	15.0/17.3	3.8	24/27	25/30
	RXBH-1724A10C	7.2/9.6	3/60	3-3.2	SINGLE	20.0/23.1	3.8	30/34	30/35
	RXBH-1724A15C	10.8/14.4	3/60	3-4.8	SINGLE	30.0/34.6	3.8	43/48	45/50
	RXBH-1724A18C	12.8/17.0	3/60	3-2.84	SINGLE	35.6/41.0	3.8	50/56	50/60
	RXBH-1724B05J	3.6/4.8	1/60	1-4.8	SINGLE	17.3/20.0	3.8	27/30	30/30
	RXBH-1724B07J	5.4/7.2	1/60	2-3.6	SINGLE	26.0/30.0	3.8	38/43	40/45
	RXBH-1724B10J	7.2/9.6	1/60	2-4.8	SINGLE	34.6/40.0	3.8	48/55	60/60



**4.6A ELECTRIC HEAT ELECTRICAL DATA: (-)H2T - continued**

AIR HANDLER MODEL (-)H2T	HEATER MODEL NO.	HEATER KW (208/240V) (480V)	PH/HZ	NO. ELEMENTS - KW PER	TYPE SUPPLY CIRCUIT SINGLE CIRCUIT MULTIPLE CIRCUIT	CIRCUIT AMPS.	MOTOR AMPACITY	MINIMUM CIRCUIT AMPACITY	MAXIMUM CIRCUIT PROTECTION
4821MT 6021ST	RXBH-1724?05J	3.6/4.8	1/60	1-4.8	SINGLE	17.3/20.0	4.0	27/30	30/30
	RXBH-1724?07J	5.4/7.2	1/60	2-3.6	SINGLE	26.0/30.0	4.0	38/43	40/45
	RXBH-1724?10J	7.2/9.6	1/60	2-4.8	SINGLE	34.6/40.0	4.0	49/53	50/60
	RXBH-1724A15J	10.8/14.4	1/60	3-4.8	SINGLE	51.9/60.0	4.0	70/80	70/80
	RXBH-1724A15J	3.6/4.8	1/60	1-4.8	MULTIPLE CKT 1	17.3/20.0	4.0	27/30	30/30
		7.2/9.6	1/60	2-4.8	MULTIPLE CKT 2	34.6/40.0	0.0	44/50	45/50
	RXBH-1724A18J	12.8/17.0	1/60	4-4.26	SINGLE	61.6/70.8	4.0	82/94	90/100
	RXBJ-1724A18J	6.4/8.5	1/60	2-4.26	MULTIPLE CKT 1	30.8/35.4	4.0	44/50	45/50
		6.4/8.5	1/60	2-4.26	MULTIPLE CKT 2	30.8/35.4	0.0	39/45	40/45
	RXBH-24A20J	14.4/19.2	1/60	4-4.8	SINGLE	69.2/80	4.0	92/105	100/110
		7.2/9.6	1/60	2-4.8	MULTIPLE CKT 1	34.6/40.0	4.0	49/55	50/60
	RXBH-24A20J	7.2/9.6	1/60	2-4.8	MULTIPLE CKT 2	34.6/40.0	0.0	44/50	45/50
	RXBH-24A25J	18.0/24.0	1/60	6-4.0	SINGLE	86.4/99.9	4.0	113/130	125/150
	RXBH-24A25J (4-ton only)	6.0/8.0	1/60	2-4.0	MULTIPLE CKT 1	28.8/33.3	4.0	41/47	45/50
		6.0/8.0	1/60	2-4.0	MULTIPLE CKT 2	28.8/33.3	0.0	36/42	40/45
		6.0/8.0	1/60	2-4.0	MULTIPLE CKT 3	28.8/33.3	0.0	36/42	40/45
	RXBH-1724A07C	5.4/7.2	3/60	3-2.4	SINGLE	15.0/17.3	4.0	24/27	25/30
	RXBH-1724A10C	7.2/9.6	3/60	3-3.2	SINGLE	20.0/23.1	4.0	30/34	30/35
	RXBH-1724A15C	10.8/14.4	3/60	3-4.8	SINGLE	30.0/34.6	4.0	43/49	45/50
	RXBH-1724A18C	12.8/17.0	3/60	3-2.84	SINGLE	35.6/41.0	4.0	50/57	50/60
	RXBH-24A20C*	14.4/19.2	3/60	3-3.2	SINGLE	40.0/46.2	4.0	55/63	60/70
	RXBH-24A20C	7.2/9.6	3/60	3-3.2	MULTIPLE CKT 1	20.0/23.1	4.0	30/34	30/35
		7.2/9.6	3/60	3-3.2	MULTIPLE CKT 2	20.0/23.1	0.0	25/29	25/30
	RXBH-24A25C*	18.0/24.0	3/60	6-4.0	SINGLE	50.0/57.8	4.0	68/77	70/80
	RXBH-24A25C (4-ton only)	9.0/12.0	3/60	3-4.0	MULTIPLE CKT 1	25.0/28.9	4.0	37/42	40/45
		9.0/12.0	3/60	3-4.0	MULTIPLE CKT 2	25.0/28.9	0.0	32/37	35/40

#### 4.6A ELECTRIC HEAT ELECTRICAL DATA: (-)H2T - continued

AIR-HANDLER MODEL (-)H2T	HEATER MODEL NO.	HEATER KW 208/240V	PH/HZ	NO. ELEMENTS - KW PER	TYPE SUPPLY CIRCUIT SINGLE CIRCUIT MULTIPLE CIRCUIT	CIRCUIT AMPS.	MOTOR AMPACITY	MINIMUM CIRCUIT AMPACITY	MAXIMUM CIRCUIT PROTECTION
6024SE	RXBH-1724?05J	3.6/4.8	1/60	1-4.8	SINGLE	17.3/20.0	4.4	28/31	30/35
	RXBH-1724?07J	5.4/7.2	1/60	2-3.6	SINGLE	26.0/30.0	4.4	38/43	40/45
	RXBH-1724?10J	7.2/9.6	1/60	2-4.8	SINGLE	34.6/40.0	4.4	49/56	50/60
	RXBH-1724A15J	10.8/14.4	1/60	3-4.8	SINGLE	51.9/60.0	4.4	71/81	80/90
	RXBH-1724A15J	3.6/4.8	1/60	1-4.8	MULTIPLE CKT 1	17.3/20.0	4.4	28/31	30/35
		7.2/9.6	1/60	2-4.8	MULTIPLE CKT 2	34.6/40.0	0	44/50	45/50
	RXBH-1724A18J	12.8/17	1/60	4-4.26	SINGLE	61.6/70.8	4.4	83/94	90/100
	RXBH-1724A18J	6.4/8.5	1/60	2-4.26	MULTIPLE CKT 1	30.8/35.4	4.4	44/50	45/50
		6.4/8.5	1/60	2-4.26	MULTIPLE CKT 2	30.8/35.4	0	39/45	40/45
	RXBH-24A20J	14.4/19.2	1/60	4-4.8	SINGLE	69.2/80	4.4	93/106	100/110
	RXBH-24A20J	7.2/9.6	1/60	2-4.8	MULTIPLE CKT 1	34.6/40.0	4.4	49/56	50/60
		7.2/9.6	1/60	2-4.8	MULTIPLE CKT 2	34.6/40.0	0	44/50	45/50
	RXBH-24A25J	18.0/24.0	1/60	6-4.0	SINGLE	86.4/99.9	4.4	114/131	125/150
	RXBH-24A25J	6.0/8.0	1/60	2-4.0	MULTIPLE CKT 1	28.8/33.3	4.4	42/48	45/50
		6.0/8.0	1/60	2-4.0	MULTIPLE CKT 2	28.8/33.3	0	36/42	40/45
		6.0/8.0	1/60	2-4.0	MULTIPLE CKT 3	28.8/33.3	0	36/42	40/45
	RXBH-24A30J (1800 CFM only)	21.6/28.8	1/60	6-4.8	SINGLE	103.8/120.	4.4	136/156	150/175
	RXBH-24A30J (5-ton only) (1800 CFM only)	7.2/9.6	1/60	2-4.8	MULTIPLE CKT 1	34.6/40.0	4.4	49/56	50/60
		7.2/9.6	1/60	2-4.8	MULTIPLE CKT 2	34.6/40.0	0	44/50	45/50
		7.2/9.6	1/60	2-4.8	MULTIPLE CKT 3	34.6/40.0	0	44/50	45/50
	RXBH-1724A07C	5.4/7.2	3/60	3-2.4	SINGLE	15.0/17.3	4.4	25/28	25/30
	RXBH-1724A10C	7.2/9.6	3/60	3-3.2	SINGLE	20.0/23.1	4.4	31/35	35/35
	RXBH-1724A15C	10.8/14.4	3/60	3-4.8	SINGLE	30.0/34.6	4.4	43/49	45/50
	RXBH-1724A18C	12.8/17.0	3/60	3-2.84	SINGLE	35.6/41.0	4.4	50/57	50/60
	RXBH-24A20C*	14.4/19.2	3/60	3-3.2	SINGLE	40.0/46.2	4.4	56/64	60/70
		7.2/9.6	3/60	3-3.2	MULTIPLE CKT 1	20.0/23.1	4.4	31/35	35/35
		7.2/9.6	3/60	3-3.2	MULTIPLE CKT 2	20.0/23.1	0	25/29	25/30
	RXBH-24A25C*	18.0/24.0	3/60	6-4.0	SINGLE	50.0/57.8	4.4	68/78	70/80
	RXBH-24A25C	9.0/12.0	3/60	3-4.0	MULTIPLE CKT 1	25.0/28.9	4.4	37/42	40/45
		9.0/12.0	3/60	3-4.0	MULTIPLE CKT 2	25.0/28.9	0	32/37	35/40
	RXBH-24A30C* (1800 CFM only)	21.6/28.8	3/60	6-4.8	SINGLE	60.0/69.4	4.4	81/93	90/100
	RXBH-24A30C (5-ton only) (1800 CFM only)	10.8/14.4	3/60	3-4.8	MULTIPLE CKT 1	30.0/34.7	4.4	43/50	45/50
10.8/14.4		3/60	3-4.8	MULTIPLE CKT 2	30.0/34.7	0	38/44	40/45	

#### NOTES:

\* Values only. No single point kit available.

- Electric heater BTUH - (heater watts + motor watts) x 3.414 (see airflow table for motor watts.)
- Supply circuit protective devices may be fuses or "HACR" type circuit breakers.
- Largest motor load is included in single circuit and multiple circuit 1.
- If non-standard fuse size is specified, use next size larger fuse size.
- J Voltage (230V) single phase air handler is designed to be used with single or three phase 230 volt electric heaters. In the case of connecting 3-phase power to the air handler terminal block without the heater, bring only two leads to the terminal block. Cap, insulate and fully secure the third lead.
- If the kit is listed under both single and multiple circuits, the kit is shipped from factory as multiple circuits. For single phase application, Jumper bar kit RXBJ-A21 and RXBJ-A31 can be used to convert multiple circuits to a single supply circuit. Refer to Accessory Section for details.
- The airflow for continuous fan is set 50% of the cooling airflow.
- ?Heater kits connection type. A=Breaker B=Terminal Block C=Disconnect Pull Out

## 4.6B ELECTRIC HEAT ELECTRICAL DATA (-)HMV

Installation of the UL Listed original equipment manufacturer provided heater kits listed in the table below is recommended for all auxiliary heating requirements.

MODEL SIZE (-)HMV	MANUFACTURER MODEL NUMBER	HEATER kW (208/240)	PH/HZ	NO. ELEMENTS - KW PER	TYPE SUPPLY CIRCUIT	CIRCUIT AMPS	MOTOR AMPACITY	MINIMUM CIRCUIT PROTECTION	MAXIMUM CIRCUIT AMPACITY	
2421ME	RXBH-1724?05J	3.6/4.8	1/60	1-4.8	SINGLE	17.3/20.0	1.7	24/28	25/30	
	RXBH-1724?07J	5.4/7.2	1/60	2-3.6	SINGLE	26.0/30.0	1.7	35/40	35/40	
	RXBH-1724?10J	7.2/9.6	1/60	2-4.8	SINGLE	34.6/40.0	1.7	46/53	50/60	
6021SE	RXBH-1724?05J	3.6/4.8	1/60	1-4.8	SINGLE	17.3/20.0	4.0	24/28	25/30	
	RXBH-1724?07J	5.4/7.2	1/60	2-3.6	SINGLE	26.0/30.0	4.0	35/40	35/40	
	RXBH-1724?10J	7.2/9.6	1/60	2-4.8	SINGLE	34.6/40.0	4.0	46/53	50/60	
	RXBH-1724A15J	10.8/14.4	1/60	3-4.8	SINGLE	51.9/60.0	4.0	70/80	70/80	
		3.6/4.8	1/60	1-4.8	MULTIPLE CKT 1	17.3/20.0	4.0	27/30	30/30	
	RXBH-1724A18J	7.2/9.6	1/60	2-4.8	MULTIPLE CKT 2	34.6/40.0	0.0	44/50	45/50	
		12.8/17.0	1/60	4-4.26	SINGLE	61.6/70.8	4.0	82/94	90/100	
		6.4/8.5	1/60	2-4.26	MULTIPLE CKT 1	30.8/35.4	4.0	44/50	45/50	
	RXBH-24A20J (3½, 4-ton only)	6.4/8.5	1/60	2-4.26	MULTIPLE CKT 2	30.8/35.4	0.0	39/45	40/45	
		14.4/19.2	1/60	4-4.8	SINGLE	69.2/80	4.0	92/105	100/110	
		7.2/9.6	1/60	2-4.8	MULTIPLE CKT 1	34.6/40.0	4.0	49/55	50/60	
	RXBH-24A25J 4821/6021 only	7.2/9.6	1/60	2-4.8	MULTIPLE CKT 2	34.6/40.0	0.0	44/50	45/50	
		18.0/24.0	1/60	6-4.0	SINGLE	86.4/99.9	4.0	113/130	125/150	
		6.0/8.0	1/60	2-4.0	MULTIPLE CKT 1	28.8/33.3	4.0	42/47	45/50	
	2417SE	6.0/8.0	1/60	2-4.0	MULTIPLE CKT 2	28.8/33.3	0.0	36/42	40/45	
		6.0/8.0	1/60	2-4.0	MULTIPLE CKT 3	28.8/33.3	0.0	36/42	40/45	
		RXBH-1724A07C	5.4/7.2	3/60	3-2.4	SINGLE	15.0/17.3	4.0	24/27	25/30
		RXBH-1724A10C	7.2/9.6	3/60	3-3.2	SINGLE	20.0/23.1	4.0	30/34	30/35
		RXBH-1724A15C	10.8/14.4	3/60	3-4.8	SINGLE	30.0/34.6	4.0	43/49	45/50
		RXBH-1724A18C	12.8/17.0	3/60	3-2.84	SINGLE	35.6/41.0	4.0	50/57	50/60
		RXBH-24A20C* (3½, 4-ton only) 6021	14.4/19.2	3/60	3-3.2	SINGLE	40.0/46.2	4.0	55/63	60/70
7.2/9.6			3/60	3-3.2	MULTIPLE CKT 1	20.0/23.1	4.0	30/34	30/35	
7.2/9.6			3/60	3-3.2	MULTIPLE CKT 2	20.0/23.1	0.0	25/29	25/30	
RXBH-24A25C* (4-ton only) 4821/6021 only		18.0/24.0	3/60	6-4.0	SINGLE	50.0/57.8	4.0	68/78	70/80	
		9.0/12.0	3/60	3-4.0	MULTIPLE CKT 1	25.0/28.9	4.0	37/42	40/45	
		9.0/12.0	3/60	3-4.0	MULTIPLE CKT 2	25.0/28.9	0.0	32/37	35/40	
RXBH-17?03J		2.25/3.0	1/60	1-3.0	SINGLE	10.8/12.5	2.2	17/19	20/20	
RXBH-1724?03J		2.25/3.0	1/60	1-3.0	SINGLE	10.8/12.5	2.2	17/19	20/20	
RXBH-1724?05J		3.6/4.8	1/60	1-4.8	SINGLE	17.3/20.0	2.2	25/28	25/30	
RXBH-1724?07J	5.4/7.2	1/60	2-3.6	SINGLE	26.0/30.0	2.2	36/41	40/45		
RXBH-1724?10J	7.2/9.6	1/60	2-4.8	SINGLE	34.6/40.0	2.2	46/53	50/60		
RXBH-1724A13J	9.4/12.5	1/60	3-4.17	SINGLE	45.1/52.1	2.2	60/68	60/70		
	3.1/4.2	1/60	1-4.17	MULTIPLE CKT 1	15.0/17.4	2.2	22/25	25/25		
	6.3/8.3	1/60	2-4.17	MULTIPLE CKT 2	30.1/34.7	0	38/44	40/45		
RXBH-1724A07C	5.4/7.2	3/60	3-2.4	SINGLE	15.0/17.3	2.2	22/25	25/25		
RXBH-1724A10C	7.2/9.6	3/60	3-3.2	SINGLE	20.0/23.1	2.2	28/32	30/35		
RXBH-1724A13C	9.4/12.5	3/60	3-4.17	SINGLE	26.1/30.1	2.2	36/41	40/45		

### NOTES:

- Supply circuit protective devices may be fuses or "HACR" type circuit breakers.
- Largest motor load is included in single circuit and multiple circuit 1.
- If non-standard fuse size is specified, use next size larger fuse size.
- J Voltage (230V) signal phase air handler is designed to be used with single or three phase 230 volt electric heaters. In the case of connecting 3-phase power to the air handler terminal block without the heater, bring only two leads to the terminal block. Cap, insulate and fully secure the third lead.
- ?Heater Kit Connection Type A=Breaker B=Terminal Block C=Pullout Disconnect

## 4.6B ELECTRIC HEAT ELECTRICAL DATA (-)HMV - continued

MODEL SIZE (-)HMV	MANUFACTURER MODEL NUMBER	HEATER kW (208/240)	PH/HZ	NO. ELEMENTS - KW PER	TYPE SUPPLY CIRCUIT	CIRCUIT AMPS	MOTOR AMPACITY	MINIMUM CIRCUIT PROTECTION	MAXIMUM CIRCUIT AMPACITY
2421ME	RXBH-1724?03J	2.25/3.0	1/60	1-3.0	SINGLE	10.8/12.5	1.7	16/18	20/20
	RXBH-1724?05J	3.6/4.8	1/60	1-4.8	SINGLE	17.3/20.0	1.7	24/28	25/30
	RXBH-1724?07J	5.4/7.2	1/60	2-3.6	SINGLE	26.0/30.0	1.7	35/40	35/40
	RXBH-1724?10J	7.2/9.6	1/60	2-4.8	SINGLE	34.6/40.0	1.7	46/53	50/60
3617SE	RXBH-17?03J	2.25/3.0	1/60	1-3.0	SINGLE	10.8/12.5	3.1	18/20	20/20
	RXBH-1724?03J	2.25/3.0	1/60	1-3.0	SINGLE	10.8/12.5	3.1	18/20	20/20
	RXBH-1724?05J	3.6/4.8	1/60	1-4.8	SINGLE	17.3/20.0	3.1	26/29	30/30
	RXBH-1724?07J	5.4/7.2	1/60	2-3.6	SINGLE	26.0/30.0	3.1	37/42	40/45
	RXBH-1724?10J	7.2/9.6	1/60	2-4.8	SINGLE	34.6/40.0	3.1	48/54	50/60
		9.4/12.5	1/60	3-4.17	SINGLE	45.1/52.1	3.1	61/69	70/70
	RXBH-1724A13J	3.1/4.2	1/60	1-4.17	MULTIPLE CKT 1	15.0/17.4	3.1	23/26	25/30
		6.3/8.3	1/60	2-4.17	MULTIPLE CKT 2	30.1/34.7	0	38/44	40/45
		10.8/14.4	1/60	3-4.8	SINGLE	51.9/60.0	3.1	69/79	70/80
	RXBH-1724A15J	3.6/4.8	1/60	1-4.8	MULTIPLE CKT 1	17.3/20.0	3.1	26/29	30/30
		7.2/9.6	1/60	2-4.8	MULTIPLE CKT 2	34.6/40.0	0	44/50	45/50
		12.8/17.0	1/60	3-5.68	SINGLE	61.6/70.8	3.1	81/93	90/100
	RXBH-1724A18J	4.3/5.7	1/60	1-5.68	MULTIPLE CKT 1	20.5/23.6	3.1	30/34	30/35
		8.5/11.3	1/60	2-5.68	MULTIPLE CKT 2	41.1/47.2	0	52/59	60/60
	RXBH-1724A07C	5.4/7.2	3/60	3-2.4	SINGLE	15.0/17.3	3.1	23/26	25/30
	RXBH-1724A10C	7.2/9.6	3/60	3-3.2	SINGLE	20.0/23.1	3.1	29/33	30/35
	RXBH-1724A13C	9.4/12.5	3/60	3-4.17	SINGLE	26.1/30.1	3.1	37/42	40/45
	RXBH-1724A15C	10.8/14.4	3/60	3-4.8	SINGLE	30.0/34.6	3.1	42/48	45/50
RXBH-1724A18C	12.8/17.0	3/60	3-5.68	SINGLE	35.5/41.0	3.1	49/56	50/60	
6024ME	RXBH-1724?07J	5.4/7.3	1/60	2-3.6	SINGLE	26.0/30.0	4.9	39/44	40/45
	RXBH-1724?10J	5.4/7.2	1/60	2-4.8	SINGLE	26.0/30.0	4.9	39/44	40/45
	RXBH-1724A15J	10.8/14.4	1/60	3-4.8	SINGLE	51.9/60.0	4.9	72/82	80/90
		3.6/4.8	1/60	1-4.8	MULTI. CKT 1	17.3/20.0	4.9	28/32	30/35
		7.2/9.6	1/60	2-4.8	MULTI. CKT	34.6/40.0	0	44/50	45/50
	RXBH-1724A18J	12.8/17	1/60	4-4.26	SINGLE	61.6/70.8	4.9	84/95	90/100
		6.4/8.5	1/60	2-4.26	MULTI. CKT 1	30.8/35.4	4.9	45/51	45/60
		6.4/8.5	1/60	2-4.26	MULTI. CKT 2	30.8/35.4	0	39/45	40/45
	RXBH-24A20J	14.4/19.2	1/60	4-4.8	SINGLE	69.2/80.0	4.4	93/107	100/110
		7.2/9.6	1/60	2-4.8	MULTI. CKT 1	34.6/40.0	4.4	50/57	50/60
		7.2/9.6	1/60	2-4.8	MULTI. CKT 2	34.6/40.0	0	44/50	45/50
	RXBH-24A25J	18.0/24.0	1/60	6-4.0	SINGLE	87.0/99.9	4.9	115/132	125/150
		6.0/8.0	1/60	2-4.0	MULTI. CKT 1	29.0/33.3	4.9	43/48	45/50
		6.0/8.0	1/60	2-4.0	MULTI. CKT 2	29.0/33.3	0	37/42	40/45
		6.0/8.0	1/60	2-4.0	MULTI. CKT 3	29.0/33.3	0	37/42	40/45
	RXBH-24A30J (5-ton only) (1800 CFM only)	21.6/28.8	1/60	4-8.6	SINGLE	103.8/120.0	4.9	150/175	136/156
		7.2/9.6	1/60	2-4.8	MULTI. CKT 1	34.6/40.0	4.9	50/60	49/56
		2-4.8	1/60	2-4.8	MULTI. CKT 2	34.6/40.0	0	45/50	44/50
	7.2/9.6	1/60	2-4.8	MULTI. CKT 3	34.6/40.0	0	45/50	44/50	

### NOTES:

- Supply circuit protective devices may be fuses or "HACR" type circuit breakers.
- Largest motor load is included in single circuit and multiple circuit 1.
- If non-standard fuse size is specified, use next size larger fuse size.
- J Voltage (230V) signal phase air handler is designed to be used with single or three phase 230 volt electric heaters. In the case of connecting 3-phase power to the air handler terminal block without the heater, bring only two leads to the terminal block. Cap, insulate and fully secure the third lead.
- ?Heater Kit Connection Type A=Breaker B=Terminal Block C=Pullout Disconnect

## 4.7 HEATER KIT SUPPLEMENTAL INFORMATION (-)H2T & (-)HMV

MFD: MO/YEAR 01/2006 AIR CONDITIONING DIVISION MADE IN THE U.S.A. / FRQ: MO/JANNE FAIT DANS L'USA

MODEL/MODELE # SERIAL/EN SERIE # M0106 38751

VOLTS 208/240 PH/HZ 1/60 MOTOR HP./F.L.A. 1/2 4.1

MOTEUR PSC/F.L.A.

ATTENTION: MARK HEATER INSTALLED / L'APPAREIL DE CHAUFFAGE DE MARQUE A INSTALLER

HEATER MODEL/MODELE D'APPAREIL DE CHAUFFAGE	TYPE SUPPLY CIRCUIT/TAPER-LE CIRCUIT DE PROVISION	VOLTAGE/TENSION	PHASE	KW	HEATER AMPS/AMPLIS D'APPAREIL DE CHAUFFAGE	MOTOR AMPS/ LES AMPLIS MOTEURS	MAXIMUM OVERCURRENT PROTECTION MAXIMUM DE OVERCURRENT	MINIMUM BRANCH CIRCUIT AMPACITY/AMPACITY MINIMUM DE CIRCUIT DE BRANCHE
NO HEAT				0.0		4.1	25	5.2
RXBH-24A05J	SINGLE	208/240	1/60	3.6/4.8	17.3/20.0	6.0	30/35	30/33
RXBH-24A07J	SINGLE	208/240	1/60	5.4/7.2	26.0/30.0	6.0	40/45	40/45
RXBH-24A10J	SINGLE	208/240	1/60	7.2/9.6	34.6/40.0	6.0	60/60	51/58
RXBH-24A15J	SINGLE	208/240	1/60	10.8/14.4	51.9/60.0	6.0	80/90	73/83
RXBH-24A15J	MULTI CKT 1	208/240	1/60	3.6/4.8	17.3/20.0	6.0	30/35	30/33
RXBH-24A15J	MULTI CKT 2	208/240	1/60	7.2/9.6	34.6/40.0	0.0	45/50	44/50
RXBH-24A18J	SINGLE	208/240	1/60	12.8/17.0	61.2/70.8	6.0	90/100	84/96
RXBH-24A18J	MULTI CKT 1	208/240	1/60	6.4/8.5	30.8/35.4	6.0	50/60	46/52
RXBH-24A18J	MULTI CKT 2	208/240	1/60	6.4/8.5	30.8/35.4	0.0	40/45	39/45
RXBH-24A20J	SINGLE	208/240	1/60	14.4/19.2	69.2/80.0	6.0	100/110	94/108
RXBH-24A20J	MULTI CKT 1	208/240	1/60	7.2/9.6	34.6/40.0	6.0	60/60	51/58
RXBH-24A20J	MULTI CKT 2	208/240	1/60	7.2/9.6	34.6/40.0	0.0	45/50	44/50
RXBH-24A07C	SINGLE	208/240	3/60	5.4/7.2	15.0/17.3	6.0	30/30	27/30
RXBH-24A10C	SINGLE	208/240	3/60	7.2/9.6	20.0/23.1	6.0	35/40	33/37
RXBH-24A15C	SINGLE	208/240	3/60	10.8/14.4	30.0/34.6	6.0	45/60	45/51
RXBH-24A18C	SINGLE	208/240	3/60	12.4/17.0	35.6/41.0	6.0	60/60	52/59
RXBH-24A18C	MULTI CKT 1	208/240	3/60	6.4/8.5	17.8/20.5	6.0	30/35	30/34
RXBH-24A18C	MULTI CKT 2	208/240	3/60	6.4/8.5	17.8/20.5	0.0	25/30	23/26
RXBH-24A20C	SINGLE	208/240	3/60	14.2/19.2	40.0/46.2	6.0	60/70	58/66
RXBH-24A20C	MULTI CKT 1	208/240	3/60	7.2/9.6	20.0/23.1	6.0	35/40	33/37
RXBH-24A20C	MULTI CKT 2	208/240	3/60	7.2/9.6	20.0/23.1	0.0	25/30	25/29

S = SINGLE CIRCUIT/CIRCUIT SIMPLE M = MULTIPLE CIRCUIT/CIRCUIT MULTIPLE

INDOOR BLOWER MOTOR LOAD INCLUDED IN CIRCUIT # 1 OR TOTAL SUPPLY WIRE MUST BE RATED AT 75°C MINIMUM COPPER CONDUCTORS ONLY. TEST EXTERNAL STATIC RANGE .1 TO .5 IN. W.C. (HEAT PUMP & ELECTRIC HEAT).

UNITS WITH ELECTRIC HEATERS: CLEARANCE TO COMBUSTIBLE MATERIAL TO BE 0 IN. TO UNIT CASING AND 0 IN. TO PLENUM AND DUCT FOR FIRST 36 IN. MODELS HAVE INTEGRAL CIRCUIT BREAKERS WHICH PROVIDE SUPPLEMENTARY OVERCURRENT PROTECTION AND SERVE AS A MAINTENANCE "DISCONNECT". SUPPLY CIRCUIT NOT TO EXCEED 120 VOLTS TO GROUND ON SINGLE PHASE UNITS. REPLACE LINE SIDE BREAKER COVER(S) AFTER MAKING WIRING CONNECTIONS TO BREAKER(S). IF BLOWER-CONTROL ASSEMBLY REQUIRES REMOVAL, SEE "WARNING HAZARDOUS VOLTAGE".

CHARGEMENT DU MOTEUR SOUFFLEUR INTERNE INCLUS DANS LE CIRCUIT # 1 OU CAPACITÉ DU CÂBLAGE D'ALIMENTATION TOTAL DOIT ÊTRE DE 75C DU MINIMUM DE CONDUCTEURS DE CUIVRE SEULEMENT. TESTER L'INTERVALLE STATIQUE EXTERNE : 1 À 5 PO W.C (THERMOPOMPE ET CHAUFFAGE ÉLECTRIQUE)

UNITÉS AVEC CHAUFFAGES ÉLECTRIQUES : LE DÉGAGEMENT AUX MATIÈRES COMBUSTIBLES DOIT ÊTRE DE 0 po AU BOITIER DE L'UNITÉ ET DE 0 po AU PLÉNUM ET CONDUIT POUR LES 36 PREMIERS po. LES MODÈLES DISPOSENT DE DISJONCTEURS INTÉGRÉS QUI FOURNISSENT UNE PROTECTION SUPPLÉMENTAIRE DE SURINTENSITÉ DE COURANT ET SERVENT DE « SECTIONNEUR » D'ENTRETIEN. LE CIRCUIT D'ALIMENTATION NE DOIT PAS DÉPASSER 120 VOLTS JUSQU'AU SOL SUR DES UNITÉS MONOPHASÉES. REMPLACER LE(S) COUVERCLE(S) DU DISJONCTEUR DU CÔTÉ SECTEUR APRÈS AVOIR EFFECTUÉ LA CONNEXION DES CÂBLAGES AU(X) DISJONCTEUR(S). SI L'ASSEMBLAGE DE CONTRÔLE DU VENTILATEUR A BESOIN D'ÊTRE DÉASSEMBLÉ, CONSULTER "AVERTISSEMENT DE TENSION DANGEREUSE"

If a heater kit is listed both Single and Multi-circuit, the kit is shipped as a Multi-circuit and will require a single point kit

Contractor should "mark or check" the left column for the kit installed

These are the required maximum and minimum circuit breaker sizes for overcurrent protection and should not be confused with the size of the breakers installed in the heater kit.

Only listed kits can be applied

Heater Kit Supplemental Information: What allows the manufacturer to use standard Circuit Breakers up to 60 amps inside the air handler, when using an approved Heater Kit?

National Electric Code (Section 424-22b) and our UL requirements allow us to subdivide heating element circuits, of less than 48 amps, using breakers of not more than 60 amps and, additionally by, NEC 424-3b, a rating not less than 125 percent of the load and NEC 424-22c, which describes the supplementary overcurrent protection required to be factory-installed within, or on the heater. The breakers in the heater kit are not, and have never been, by NEC, intended to protect power wiring leading to the air handler unit. The breakers in the heating kit are for short circuit protection. All internal unit wiring, where the breakers apply, has been UL approved for short circuit protection.

Ampacity, (not breaker size), determines supply circuit wire size. The ampacity listed on the unit rating plate and the Maximum and Minimum circuit breaker size (noted above) or in the units specification sheet or installation instructions provides the information to properly select wire and circuit breaker/protector size. The National Electric Code (NEC) specifies that the supply or branch circuit must be protected at the source.

## 5.0 AIR HANDLER EQUIPPED WITH ECONET™ COMMUNICATIONS

The EcoNet™ RH2T/RHMV-series of air handlers are designed to operate with conventional 24VAC controls or with an EcoNet™ communicating system.

For the EcoNet™ communicating system, you must have:

- Air handler equipped with a *EcoNet™ Control*
- Condensing unit or heat pump equipped with a *EcoNet™ control*.
- An EcoNet™ Control Center

If your equipment does not meet this criteria, you must wire it using conventional 24VAC thermostat control wiring. Reference Section 5.3.

### 5.1 *EcoNet™* AIR HANDLER PHYSICAL INTERFACE

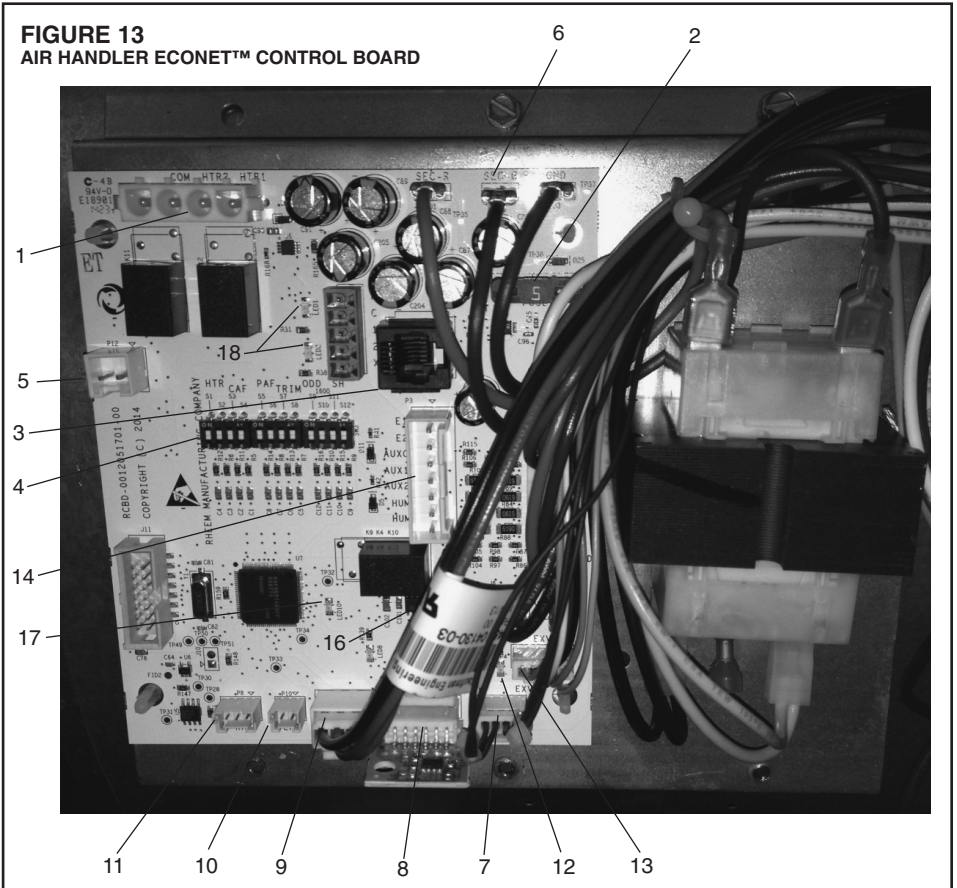

1. Electrical heater connection
2. 5A fuse
3. RJ14 connector for service tool
4. Dip switch (heater [HTR], cooling airflow selection [CAF], heating airflow selection [PAF], trim selection, on demand dehumidification [ODD], EXV selections)
5. 1st stage airflow hold pins (short to hold low stage during ratings test)
6. Power connection (24VAC)
7. Suction and coil thermister connection
8. Model data card
9. Suction pressure transducer
10. Leaving air temperature (LAT) thermister (optional)
11. Return air temperature (RAT) thermister (optional)
12. Electronic expansion valve indicator lights
13. Electronic expansion valve connection
14. Communications and optional harness

15. Thermostat connection (at far right of board).
16. Airflow indicator LED (LED 8)
17. Alert/alarm indicator LED (LED 10)
18. Communication LED 1 and 2

## 5.2 ECONET™ CONTROL BOARD COMMUNICATION WIRING

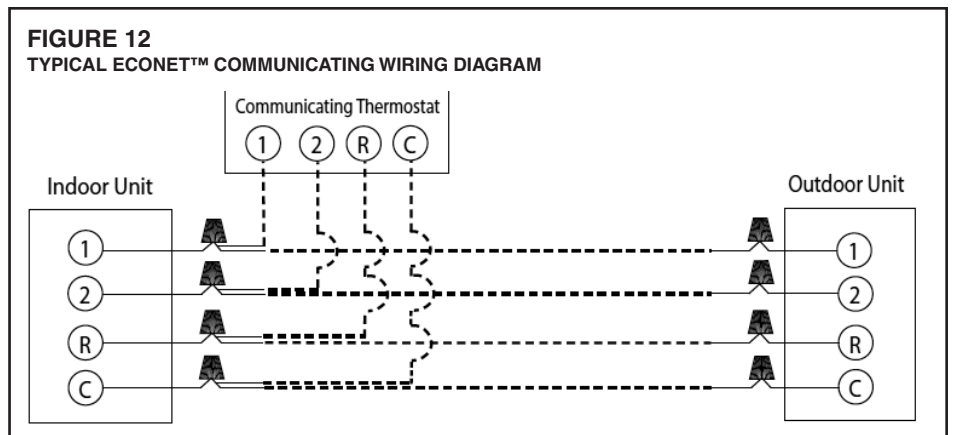

The EcoNet™ enabled RH2T/RH MV series air handler control, Figure 13, has the following features:

- Memory Card – The memory card stores all information needed for unit operation. Once the system is wired for the *EcoNet™ Control*, this information is available to the control center and outdoor unit.
- An automotive-style ATC blade fuse for transformer protection (5 amp).
- An on-board LED to indicate blower CFM. (for constant cfm models only).
- An RJ-14 port for use with a diagnostic tool.
- Constant CFM and Torque outputs for compatibility for all EcoNet™ enabled Air Handlers.
- Output for Electronic expansion valve
- Inputs for factory installed suction temperature sensor and pressure transducer for optimal control of the electronic expansion device.
- Inputs for field installed supply and return air temperature sensors (available in kit RXHT-A02)
- DIP switches for airflow adjustments (for constant cfm models only).

**IMPORTANT:** The DIP switches are NOT used when the air handler is wired in EcoNet™ communicating mode or with constant torque air handlers. Airflow adjustments are performed via the thermostat.

### **Installation Verification**

- Both SH Dip switches should be in the off position.
- 24V AC power on R&C must be present at the control for the air handler to operate, reference Figure 12.
- Line voltage must be present at the control for indoor blower operation.
- The LED 1 & 2 will flash green and red in normal operation. A flashing green light indicates communications are being received from the other EcoNet™ enabled controls on the communication bus. A flashing red light indicates communications are being transmitted to the other EcoNet™ enabled controls on the communication bus. When both lights are flashing the E1 and E2 wires are connected correctly and the EcoNet™ communications are working properly.

**IMPORTANT:** Diagnostic port is not a phone jack. Connecting to a telephone or telephone system will result in a loss of communication between the EcoNet™ enabled systems.

**FIELD WIRE SIZE FOR 24 VOLT THERMOSTAT CIRCUITS**

Thermostat Load - Amps	SOLID COPPER WIRE - AWG.					
	3.0	16	14	12	10	10
2.5	16	14	12	12	10	10
2.0	18	16	14	12	12	10
	50	100	150	200	250	300
	<b>Length of Run - Feet (1)</b>					

(1) Wire length equals twice the run distance.

NOTE: Do not use control wiring smaller than No. 18 AWG between thermostat and outdoor unit.

**5.3 CONVENTIONAL 24VAC THERMOSTAT CONTROL WIRING**

The RA17/RP17/RP20/RA20-series of condensing units allow the installer to use conventional 24VAC control wiring and a conventional thermostat for proper unit operation.

**IMPORTANT:** The preferred method of unit installation and operation is by the EcoNet™ Communicating System, which allows access to the fault history of the system. This diagnostic information is not available when the RA17/RP17/RP20/RA20 unit is using a conventional thermostat. Reference section 5.2 EcoNet™ Control Wiring.

Thermostat control wiring requires a minimum of seven (7) wires for proper unit operation:

- R – 24VAC
- C – 24VAC common
- G – Constant Fan
- W1 – First stage electric heat
- W2 – Second stage electric heat
- Y1 – First stage operation
- Y2 – Second stage operation

Optional wiring:

- ODD – On demand humidification

**NOTE:** W1 and W2 may be jumpered together to energize all the electric heat when a call for electric heat is received if warmer supply air is desired.

**NOTE:** When using 24VAC thermostat control wiring, the serial communicating control will ignore any inputs to Data wire 1 and Data wire 2.

**IMPORTANT:** Class 2 low voltage control wire should not be run in conduit with power wiring and must be separated from power wiring, unless Class 1 wire of proper voltage rating is used.

Low voltage control wiring should be 18 AWG color-coded (105°C minimum). For lengths longer than 100 ft., 16 AWG wire should be used.

Low voltage control connections are made by extending wires from top of air handler using wire nuts.

See wiring diagrams attached to indoor and outdoor sections to be connected

Do not leave excess field control wiring inside unit, pull excess control wire to outside of unit and provide strain relief for field wiring on inside of cabinet where wiring penetrates cabinet.

Make sure, after installation, separation of control wiring and power wiring has been maintained.

**5.4 EcoNet™ CONTROL WIRING**

EcoNet™ requires four (4) control wires for unit operation:

- R – 24VAC
- C – 24VAC common
- E1 – Data wire 1
- E2 – Data wire 2

Wiring sizing for EcoNet™ communication is identical to systems using low voltage 24V wires.

**Note:** The EcoNet™ system requires a minimum 18 AWG.

**IMPORTANT:** Class 2 low voltage control wire should not be run in conduit with power wiring and must be separated from power wiring, unless Class 1 wire of proper voltage rating is used.



- The four 18AWG low voltage control wires must be installed from the thermostat to the indoor unit and from indoor unit to the outdoor unit. The wire length between the thermostat and indoor unit should not be greater than 100 feet. The wire length between the indoor unit and outdoor unit should not be greater than 125 feet.
- Low voltage control connections are made by extending wires from top of air handler using wire nuts.
- See wiring diagrams attached to indoor and outdoor sections to be connected
- Do not leave excess field control wiring inside unit, pull excess control wire to outside of unit and provide strain relief for field wiring on inside of cabinet at point wiring penetrates cabinet.
- Make sure, after installation, separation of control wiring and power wiring has been maintained.

## 5.5 USING THE ON-BOARD LED TO DETERMINE BLOWER CFM

When the EcoNet™ air handler control is connected to a communicating constant cfm indoor motor (RHMV air handlers), the CFM LED indicates blower output by flashing one (1) flash for every 100 CFM of airflow. The LED will pause 1/10 second between each flash. (See Figure 13.)

## 5.6 AIRFLOW ADJUSTMENTS WITH THE *ECONET™* AIR HANDLER CONTROL

The EcoNet™ enabled RHMV air handler may operate using *EcoNet™ communications* or via traditional thermostat wiring. When the air handler is wired for the *EcoNet™ communications* using Data wire E1 and Data wire E2, the DIP switches on the *EcoNet™* control have NO affect on the airflow.

**IMPORTANT:** When using the *EcoNet™ air handler control with an EcoNet™ enabled outdoor unit and control center*, the DIP switches have no affect on airflow or on air handler performance.

**IMPORTANT:** Regardless of wiring configuration at the install location, the dip switches do nothing to adjust airflow for the RH2T EcoNet™ enabled air handler.

### 5.6.1 COOLING AIRFLOW SETTINGS (BY TONNAGE)

The EcoNet™ enabled RHMV-series of air handlers automatically set cooling airflow when using the *EcoNet™ Control Center* whereas the RH2T air handlers are pre-set from the factory to work with Rheem outdoor products. The RHMV air handler detects the tonnage of the condensing unit/heat pump via EcoNet™ communications and sets airflow for optimum performance and comfort. Refer to Table 1-3 for the airflow provided when the EcoNet™ enabled air handler is matched to the RA17/RP17/RA20/RP20 condensing units.

**TABLE 1**  
RH2T AIRFLOW WHEN MATCHED TO THE (-)A17

Condensing Unit Model	RH2T Airflow	
	2nd Stage	1 <sup>st</sup> Stage
(-)A1724	720	535
(-)A1736	1080	800
(-)A1748	1400	1050
(-)A1760	1600	1200

**TABLE 2**  
RH2T AIRFLOW WHEN MATCHED TO THE (-)P17

Condensing Unit Model	RH2T Airflow	
	MAX SPEED	MINIMUM AND INTERMEDIATE SPEEDS
(-)P1724	750	535
(-)P1736	1230	670
(-)P1748	1430	890
(-)P1760	1600	900

**\*Note:** The RH2T air handlers are shipped from the factory utilizing taps 4 and 5 for airflow. When installing an RH2T with an (-)P17 move the G/BK wire from tap 4 to tap 1 for the correct minimum and intermediate cfm.

**TABLE 3**  
RHMV AIRFLOW WHEN MATCHED TO THE (-)A20 OR (-)P20

Condensing Unit Model	RHMV Airflow					
	Cooling Airflow			Heating Airflow		
	MAX Airflow	Intermediate Airflow	MINIMUM Airflow	MAX Airflow	INTERMEDIATE Airflow	MINIMUM Airflow
(-)P1724	750	540	540	750	550	550
(-)P1736	1235	660	660	1235	660	660
(-)P1748	1420	860	860	1400	870	870
(-)P1760	1575	875	875	1500	840	840
(-)A2024	835	460	310	-	-	-
(-)A2036	1235	665	520	-	-	-
(-)A2048	1565	830	480	-	-	-
(-)A2060	1670	755	500	-	-	-
(-)P2024	855	580	325	825	655	565
(-)P2036	1235	660	470	1275	950	620
(-)P2048	1665	890	555	1600	835	540
(-)P2060	1670	755	500	1665	1300	1200

### 5.6.2 COOLING AIRFLOW ADJUSTMENT (TRIM)

The *EcoNet™ Air Handler Control* does allow the installer to tweak the cooling airflow +/- 10% to suit the installation. When using the *EcoNet™ Air Handler Control* in communicating mode, the airflow can only be adjusted using the *EcoNet™ Control Center*. To adjust the airflow, go to the Installer menu under settings and select the desired adjustment. (Refer to the following table).

Menu Option	Result
None	No airflow adjustment is made
High	+10%
Low	-10%

**IMPORTANT:** Cooling airflow adjustment is accessible via the *EcoNet™ Control Center* or via a service tool. Refer to their instructions to access the cooling airflow adjustment menu.

**NOTE:** Cooling airflow adjustments are in effect for cooling operation only. They are ignored when in heating mode or when electric heat is activated.

**Note:** These adjustments will be available for the RHMV air handlers ONLY.

For legacy installations of the RHMV air handlers use the TRIM dip switches as follows to select the airflow adjustments as necessary.

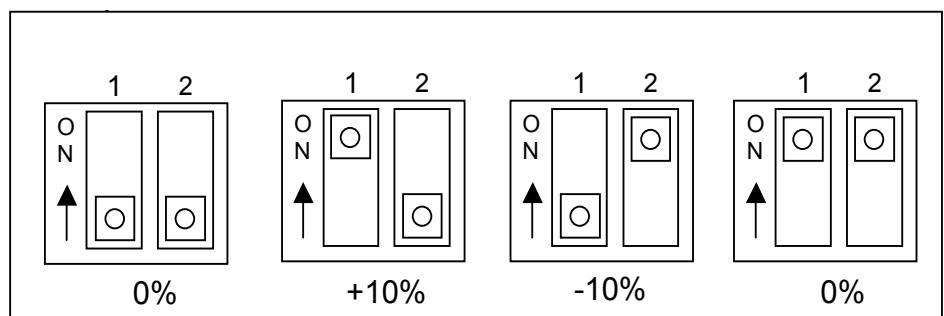

**IMPORTANT:** The DIP switches are active only when using a conventional 24VAC thermostat and a communicating variable speed blower motor. The dip switches are not active in the RH2T air handlers.

**NOTE:** Airflow adjustment is active for cooling operation only. Cooling airflow adjustments are ignored when electric heat is active.

### 5.6.3 COOLING/HEATING AIRFLOW SETTINGS

When using the RHMV air handler with a conventional 24VAC thermostat, the air handler must be configured to deliver the proper airflow. Adjust the CAF and PAF dip switches per the following table for proper unit operation:

RHMV	Outdoor Unit	Cooling Airflow (CAF)		Heating Airflow (PAF)		Cooling Airflow (CFM)			Heating Airflow (CFM)		
		Switch 1 Position	Switch 2 Position	Switch 1 Position	Switch 2 Position	Max Airflow (Y2 + Y1)	INTERMEDIATE Airflow*	MINIMUM Airflow (Y1)**	Max Airflow (Y2 + Y1)	INTERMEDIATE Airflow*	MINIMUM Airflow (Y1)**
(-)HVM2417SE	(-)P1724	Off	Off	Off	Off	750	540	540	750	550	550
(-)HVM3617SE	(-)P1736	Off	Off	Off	Off	1235	660	660	1235	660	660
(-)HVM2421ME	(-)A2024	Off	Off	-	-	835	460	310	-	-	-
(-)HVM2421HE	(-)P2024	Off	Off	Off	Off	855	580	325	825	655	565
(-)HVM6021SE	(-)P2048	Off	Off	Off	Off	1660	890	630	1600	855	530
(-)HVM6021SE	(-)A2048	On	Off	-	-	1565	835	595	-	-	-
(-)HVM6021SE	(-)P2036	Off	On	Off	On	1235	660	470	1225	950	620
(-)HVM6024ME	(-)A2060 / (-)P2060	Off	Off	-	-	1670	755	500	1665	1300	1200

\*NOTE: INTERMEDIATE Airflow listed above is for applications using legacy thermostat connections.

\*\*NOTE: When utilizing the (-)HVM air handlers with a legacy thermostat, the low stage airflow will only be held with a Y1 signal for 15 minutes before the air handler automatically stages to the INTERMEDIATE airflow setting.

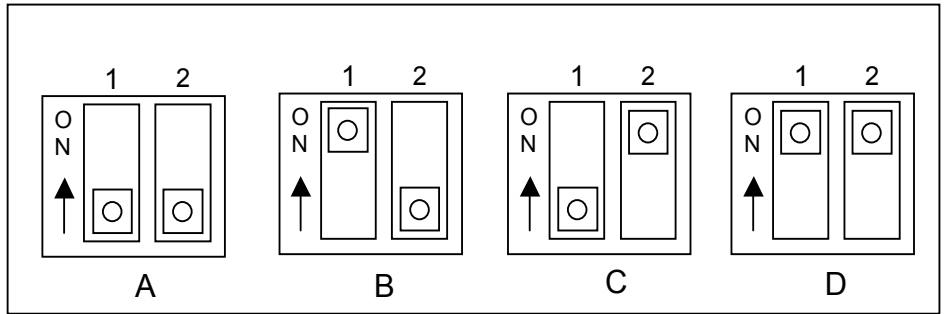

#### 5.6.4 ELECTRIC HEAT AIRFLOW

The RH2T and RHMV-series of air handlers are factory programmed to provide adequate airflow for the maximum electric heat (auxiliary heat) allowed for a given model. The RHMV has further airflow adjustments for lower kW heater applications. These adjustments are accessible via the *EcoNet™ Control Center*. Refer to the Control Center instructions to access the Installer menu.

Air Handler Model	Electric Heat Airflow Selection	Airflow	Electric Heat Size
(-)HMV2417SEAC*	Airflow 1	800	Above 15kW
	Airflow 2	600	3kW to 13kW
	Airflow 3	800	15kW to 18kW
	Airflow 4	600	3kW to 13kW
(-)HMV2421MEAC*	Airflow 1	800	Above 15kW
	Airflow 2	600	3kW to 13kW
	Airflow 3	800	15kW to 18kW
	Airflow 4	600	3kW to 13kW
(-)HMV2421HEAC*	Airflow 1	800	Above 15kW
	Airflow 2	600	3kW to 13kW
	Airflow 3	800	15kW to 18kW
	Airflow 4	600	3kW to 13kW
(-)HMV3617SEAC*	Airflow 1	1200	15kW to 18kW
	Airflow 2	600	3kW to 13kW
	Airflow 3	1000	15kW to 18kW
	Airflow 4	600	3kW to 13kW
(-)HMV6021SEAC*	Airflow 1	1600	Below 25kW
	Airflow 2	1600	Below 25kW
	Airflow 3	800	15kW to 18kW
	Airflow 4	600	3kW to 13kW
(-)HMV6024MEAC*	Airflow 1	1725	20kW to 25 kW
	Airflow 2	800	3kW to 13 kW
	Airflow 3	1600	20kW to 25kW
	Airflow 4	800	15kW to 18kW

**Note:** The RH2T Electric heat Air flow will be the highest airflow setting based on the 24V wiring configuration used at installation. The factory setting will be for high static duct work or tap 5.

For conventional 24VAC thermostat installations use the HTR dip switches to set the appropriate airflow for heater sizes per the following table.

Air Handler Model	HTR Dip Switch		Airflow	Electric Heat Size
	Switch 1 Position	Switch 2 Position		
(-)HMV2417SEAC*	Off	Off	800	Above 15kW
	On	Off	600	3kW to 13kW
	Off	On	800	15kW to 18kW
	On	On	600	3kW to 13kW
(-)HMV2421MEAC*	Off	Off	800	Above 15kW
	On	Off	600	3kW to 13kW
	Off	On	800	15kW to 18kW
	On	On	600	3kW to 13kW
(-)HMV2421HEAC*	Off	Off	800	Above 15kW
	On	Off	600	3kW to 13kW
	Off	On	800	15kW to 18kW
	On	On	600	3kW to 13kW
(-)HMV3617SEAC*	Off	Off	1200	15kW to 18kW
	On	Off	600	3kW to 13kW
	Off	On	1000	15kW to 18kW
	On	On	600	3kW to 13kW
(-)HMV6021SEAC*	Off	Off	1600	Below 25kW
	On	Off	1600	Below 25kW
	Off	On	800	15kW to 18kW
	On	On	600	3kW to 13kW
(-)HMV6024MEAC*	Off	Off	1725	20kW to 25 kW
	On	Off	800	3kW to 13 kW
	Off	On	1600	20kW to 25kW
	On	On	800	15kW to 18kW

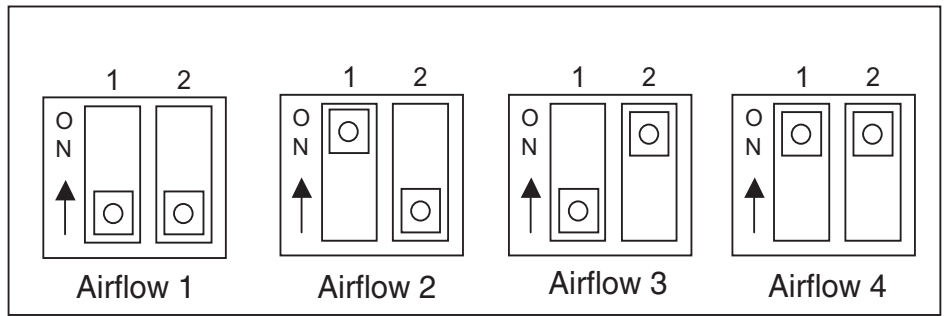

**TABLE 4**  
ODD TERMINAL

INDOOR AMBIENT CONDITION	INPUT TO "ODD" TERMINAL (FROM HUMIDISTAT)
HIGH HUMIDITY	Ø VAC
LOW HUMIDITY	24 VAC

## 5.7 COOLING MODE DEHUMIDIFICATION

**FIGURE 14**  
ON DEMAND DEHUMIDIFICATION DIP SWITCH



The EcoNet™ air handler control is shipped with “On Demand Dehumidification” (ODD) turned OFF. On Demand Dehumidification may be activated when the *EcoNet™ Control System™* has an on-board humidity sensor.

**IMPORTANT:** On Demand Dehumidification is accessible via the *EcoNet™ Control System™* or via a service tool. Refer to their instructions to access the ODD airflow adjustment menu.

The (-)HVM-series air handler is shipped with “On Demand Dehumidification” (ODD) turned OFF. On Demand Dehumidification is used in conjunction with a traditional 24VAC thermostat equipped with an on-board humidity sensor. Activate ODD by turning DIP switch “ODD” ON. ODD operation is controlled by the indoor humidity sensed at the control center. Operation is:

Normal Humidity (humidity BELOW the thermostat set point):

Normal Humidity	Result
A 24VAC signal is applied to the ODD terminal	Full rated airflow is delivered by the blower

High Humidity (humidity ABOVE the thermostat set point):

High Humidity	Result
No signal applied to the ODD terminal	Airflow is reduced by a preset amount to increase latent capacity

The (-)HVM air handler is programmed to provide maximum efficiency and optimum humidity removal. When high humidity is detected, the air handler reduces cooling airflow defined in Table 5.

**TABLE 5**  
**ODD AIRFLOW REDUCTION**

RHMV	Outdoor Unit	Cooling Airflow (CAF)		Airflow (CFM)	
		Switch 1 Position	Switch 2 Position	High Stage (Y2)	Low Stage
RHMV2421ME	(-)RA2024/	All positions		680	170
RHMV2421HE	(-)RP2024	All positions		725	275
RHMV6021SE	(-)RA2036 / (-)RP2036	Off	On	1040	260
RHMV6021SE	(-)RA2048 / (-)RP2048	On	Off	1360	340
RHMV6021SE	(-)RA2060 / (-)RP2060	Off	Off	1470	370
(-)HVM2417SE	(-)P1724	All Positions		640	460
(-)HVM3617SE	(-)P1736	All Positions		1050	530
(-)HVM2421ME	(-)A2024	All Positions		710	265
(-)HVM2421HE	(-)P2024	All Positions		725	275
(-)HVM6021SE	(-)P2048	Off	Off	1411	535
(-)HVM6021SE	(-)A2048	On	Off	1330	505
(-)HVM6021SE	(-)P2036	Off	On	1050	400
(-)HVM6024ME	(-)A2060 / (-)P2060	All Positions		1420	400

**IMPORTANT:** The DIP switches are active only when using conventional a 24VAC thermostat. If using the *EcoNet™ Control System*, refer to Section 5.6.2 and 5.6.3 for adjusting airflows.

**NOTE:** ODD airflow adjustments are active for cooling operation only. They are ignored when the heat pump is in heating mode or when electric heat is activated.

## 5.8 AIR HANDLER DIAGNOSTIC CODES

Descriptions of the air handler *EcoNet™ Control System* diagnostic codes are provided below. These codes can be displayed at the thermostat or via a diagnostic tool. The flash codes are displayed on the *EcoNet™ Air Handler control* via LED 10 (see Section 5.1).

**IMPORTANT:** Air handler diagnostic codes are available at the thermostat when the system is wired for the *EcoNet™ Control System*. If using the *EcoNet™ Control System*, refer to the following diagnostic codes.

## AIR HANDLER DIAGNOSTIC CODES

Descriptions of the ICC diagnostic codes are provided below:

LED Flash Code	Fault Code displayed in Control Center fault recall	Fault	Fault Severity (0=minor, 1=critical)	Status/Possible Cause – Troubleshooting Information
2	A103 or 106	No model data present	1	•Replace memory card with correct system information.
3	A102	Motor size is not correct for model of air handler	1	•Replace the motor with correct horsepower motor. •Replace the memory card with correct system information.
4	A105	Blower fault – Run The ECM motor is running but has a fault	1	• TEST the ECM for proper operation.
4	A104	Motor no run fault – No Run The ECM motor is not operating	1	• Make sure the ECM motor wiring harness is plugged into the ECM motor and control board. •Test the ECM motor for proper operation.
4	A101	Blower motor is not communicating The ECM motor is not communicating to the air handler control board.	1	•Make sure the ECM motor wiring harness is plugged into the ECM motor and control board. •Test the ECM motor proper operation using a service tool.
5	A107	Return sensor out of range The resistance of the sensor out of range for normal operation.	0	•Make sure the sensor is plugged into the air handler control board. • Check the resistance of the sensor. Replace if it is out of tolerance.
6	A108	Leaving air sensor out of range The resistance of the sensor out of range for normal operation.	0	• Make sure the sensor is plugged into the air handler control board.
7	A110	Evaporator thermistor failure		•Check the evaporator thermistor to ensure a proper connection to the control is present. •This occurs only on air handlers not equipped with a low pressure transducer.
8	111	No Valid Suction Temp	1	•Make sure the sensor is plugged into the air handler control board. • Check the resistance of the sensor. Replace if it is out of tolerance.
10	A109	Suction pressure out of range	0	•Check the suction pressure transducer to ensure a proper connection to the control is present. •If operating in heating mode this flash code is normal.
11	111	Control fault The air handler control is not functioning.	1	•Check for proper system operation. • Replace control.

**NOTE:** Flash codes can be seen on LED10 at the center of the control board.

**NOTE:** If multiple status codes are active concurrently, the highest priority status code is displayed (the highest priority is actually the lowest blink rate). If a status code is flashing and a new one of higher priority occurs the new status code will flash. The priority is assigned a number where (1) is considered the highest priority. The flash codes will repeat continuously until cleared or overridden by a higher priority code. The operational code information is also passed to the user interface when requested.

WIRE COLOR CODE			
BK – BLACK	G – GREEN	PR – PURPLE	Y – YELLOW
BR – BROWN	GY – GRAY	R – RED	
BL – BLUE	O – ORANGE	W – WHITE	

**FIGURE 15**  
TYPICAL 2-STAGE THERMOSTAT: 2-STAGE/VARIABLE SPEED  
CONDENSING UNIT WITH ELECTRIC HEAT

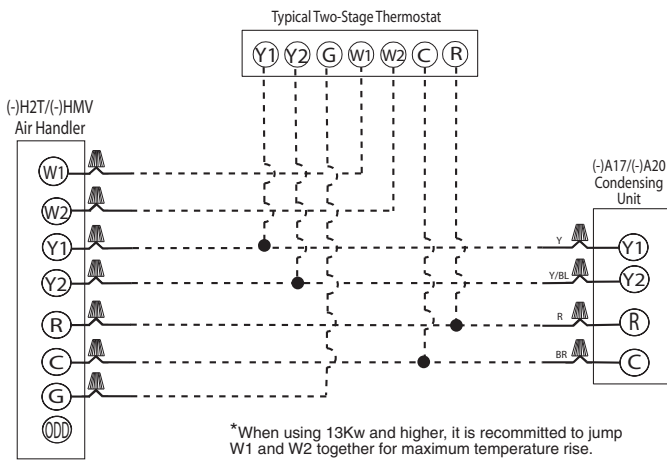

\*When using 13Kw and higher, it is recommended to jump W1 and W2 together for maximum temperature rise.

WIRING INFORMATION  
Line Voltage  
-Field Installed - - - -  
-Factory Standard - - - -

**DIP SWITCH POSITIONS**

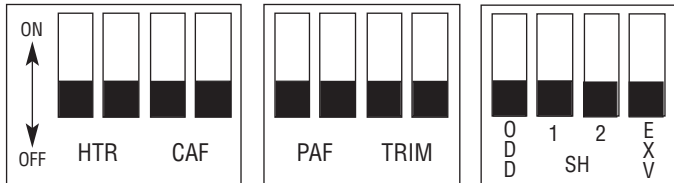

**FIGURE 16**  
TYPICAL TWO-STAGE THERMOSTAT: 2-STAGE/VARIABLE SPEED CONDENSING UNIT WITH ELECTRIC HEAT USING A HUMIDISTAT FOR DEHUMIDIFICATION\*.

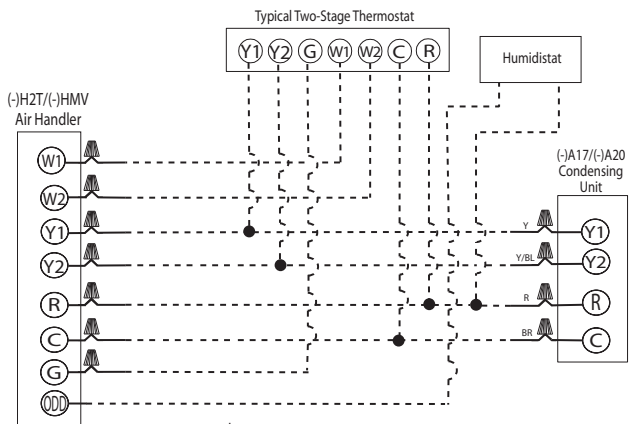

\*When using 13Kw and higher, it is recommended to jump W1 and W2 together for maximum temperature rise.

WIRING INFORMATION  
Line Voltage  
-Field Installed - - - -  
-Factory Standard - - - -

\*See Section 5.15 for proper DIP switch selection.

**DIP SWITCH POSITIONS**

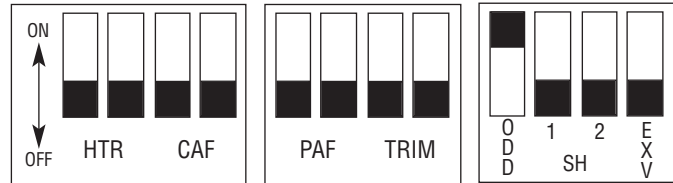

**FIGURE 17**  
TYPICAL TWO-STAGE THERMOSTAT: 2-STAGE CONDENSING UNIT WITH ELECTRIC HEAT USING A 2-STAGE/VARIABLE SPEED THERMOSTAT WITH DEHUMIDIFICATION\*

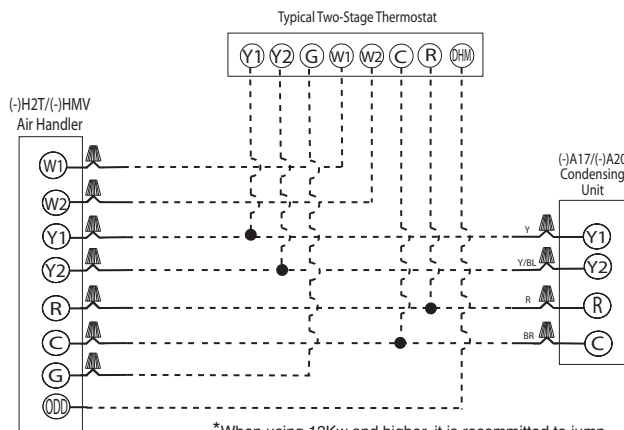

\*When using 13Kw and higher, it is recommended to jump W1 and W2 together for maximum temperature rise.

WIRING INFORMATION  
Line Voltage  
-Field Installed - - - -  
-Factory Standard - - - -

\*See Section 5.15 for proper DIP switch selection.

**DIP SWITCH POSITIONS**

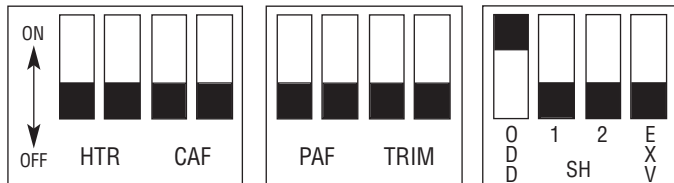



WIRE COLOR CODE			
BK - BLACK	G - GREEN	PR - PURPLE	Y - YELLOW
BR - BROWN	GY - GRAY	R - RED	
BL - BLUE	O - ORANGE	W - WHITE	

**FIGURE 18**  
**TYPICAL TWO-STAGE THERMOSTAT: 2-STAGE/VARIABLE SPEED CONDENSING UNIT WITH ELECTRIC HEAT USING A HUMIDISTAT FOR HUMIDIFICATION\***

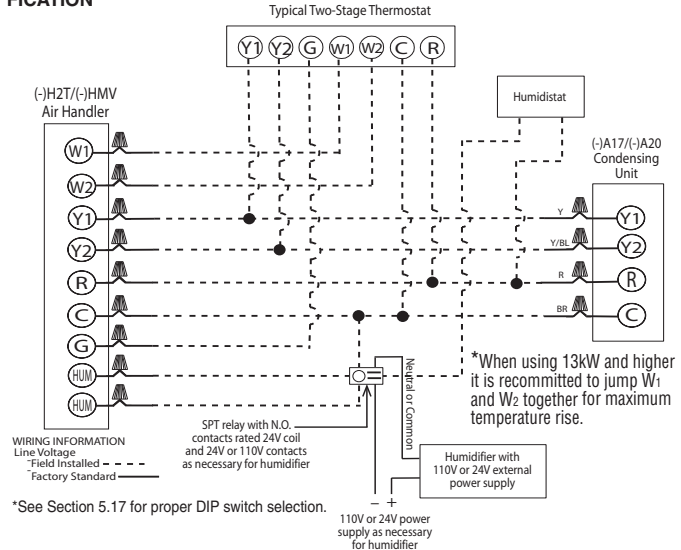

**DIP SWITCH POSITIONS**

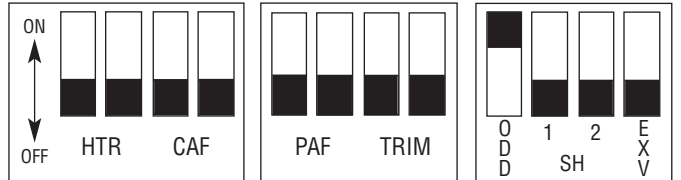

**FIGURE 19**  
**TYPICAL TWO-STAGE THERMOSTAT: 2-STAGE CONDENSING UNIT WITH ELECTRIC HEAT USING A 2-STAGE/VARIABLE SPEED THERMOSTAT WITH DEHUMIDIFICATION AND HUMIDIFICATION\***

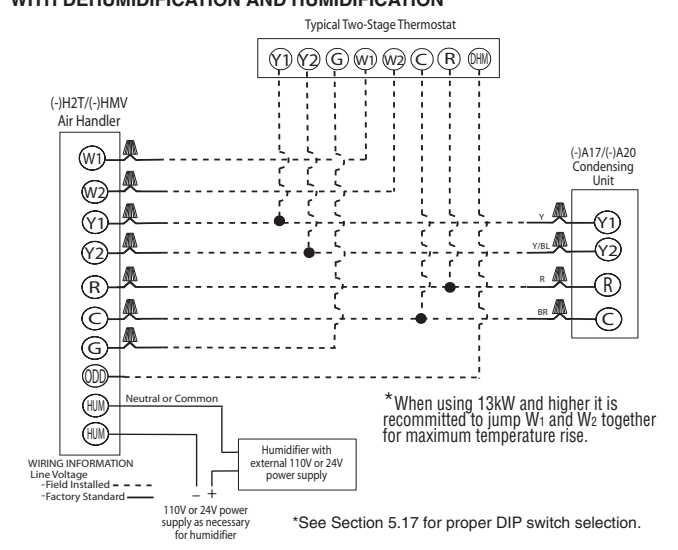

**DIP SWITCH POSITIONS**

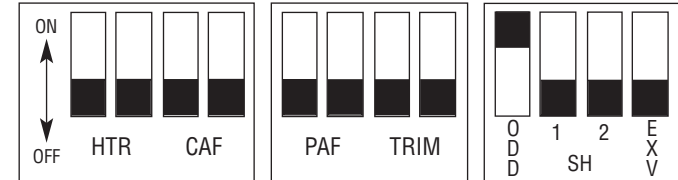

**FIGURE 20**  
**TYPICAL TWO-STAGE THERMOSTAT: 2-STAGE/VARIABLE SPEED CONDENSING UNIT WITH ELECTRIC HEAT USING A HUMIDISTAT FOR HUMIDIFICATION WITH HUMIDIFIER HAVING INTERNAL POWER SUPPLY\***

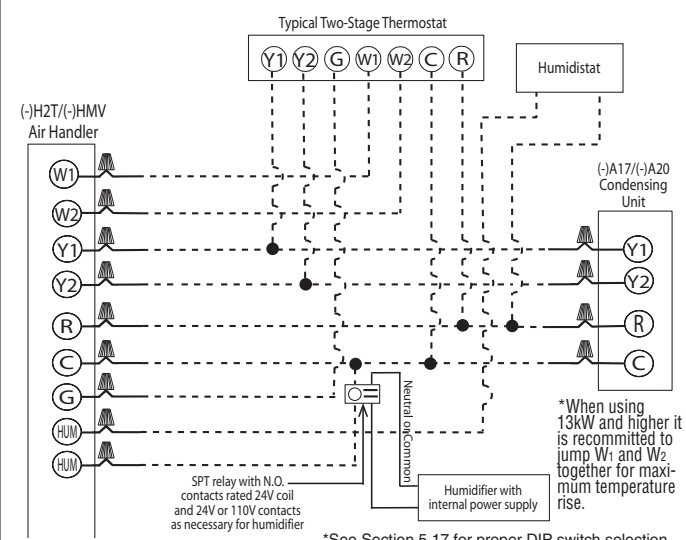

**DIP SWITCH POSITIONS**

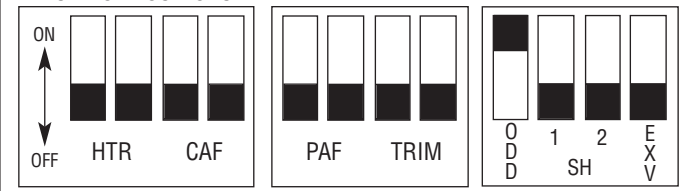

WIRE COLOR CODE			
BK - BLACK	G - GREEN	PR - PURPLE	Y - YELLOW
BR - BROWN	GY - GRAY	R - RED	
BL - BLUE	O - ORANGE	W - WHITE	

**FIGURE 21**  
TYPICAL TWO-STAGE THERMOSTAT: 2-STAGE CONDENSING UNIT WITH ELECTRIC HEAT USING A 2-STAGE/VARIABLE SPEED THERMOSTAT WITH DEHUMIDIFICATION AND HUMIDIFICATION WITH HUMIDIFIER HAVING INTERNAL POWER SUPPLY\*

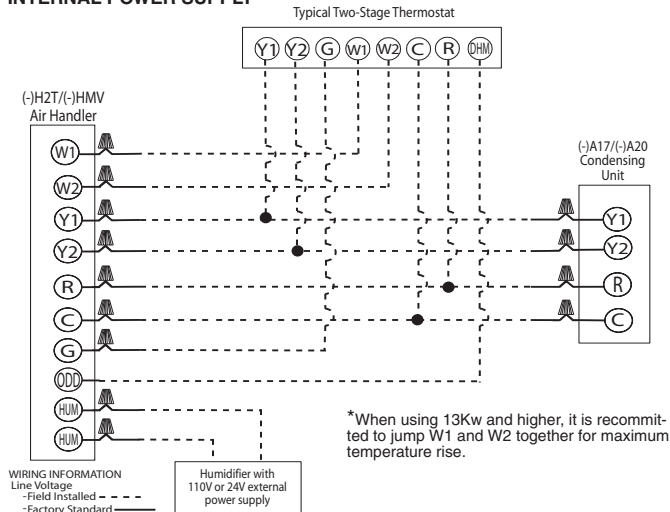

**DIP SWITCH POSITIONS**

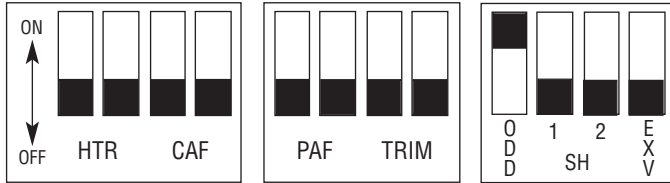

**FIGURE 22**  
TYPICAL 2-STAGE THERMOSTAT: (-)P17/(-)P20 HEAT PUMP WITH ELECTRIC HEAT

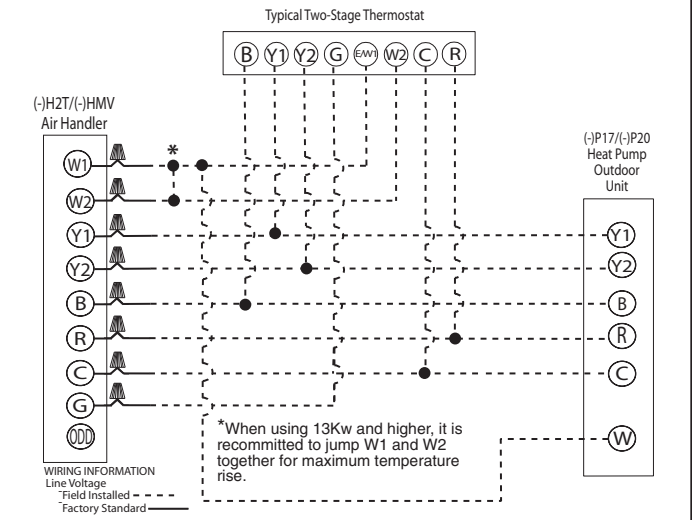

**DIP SWITCH POSITIONS**

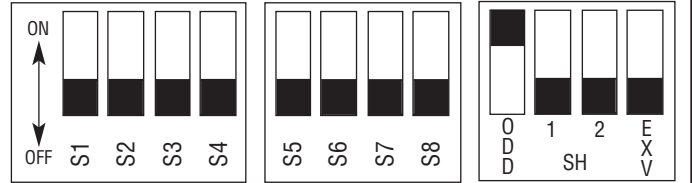

**FIGURE 23**  
TYPICAL TWO-STAGE THERMOSTAT: (-)P17/(-)P20 HEAT PUMP WITH ELECTRIC HEAT USING A HUMIDISTAT FOR DEHUMIDIFICATION\*

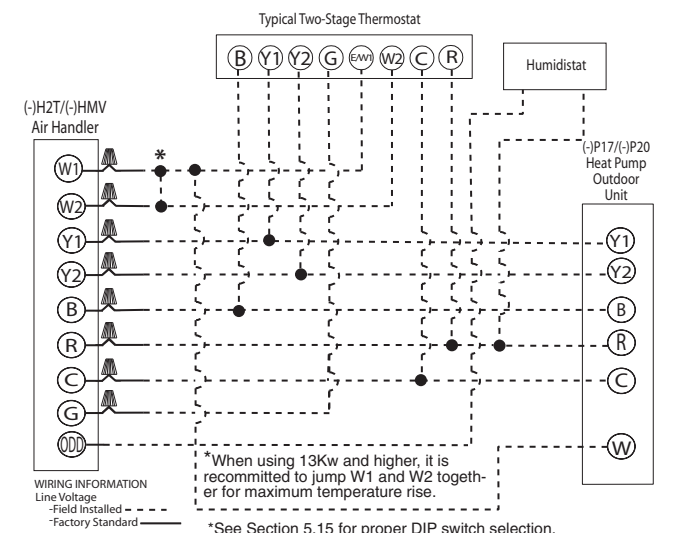

**DIP SWITCH POSITIONS**



WIRE COLOR CODE			
BK - BLACK	G - GREEN	PR - PURPLE	Y - YELLOW
BR - BROWN	GY - GRAY	R - RED	
BL - BLUE	O - ORANGE	W - WHITE	

**FIGURE 24**  
**TYPICAL TWO-STAGE THERMOSTAT: (-)P17/(-)P20 HEAT PUMP WITH ELECTRIC HEAT USING A TWO-STAGE THERMOSTAT WITH DEHUMIDIFICATION\***

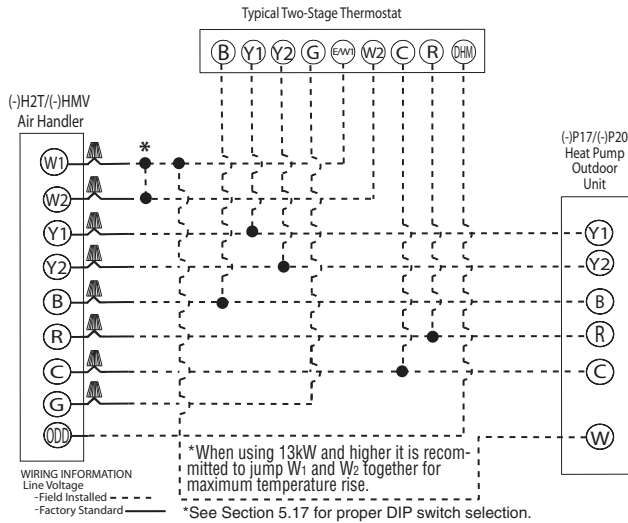

**DIP SWITCH POSITIONS**

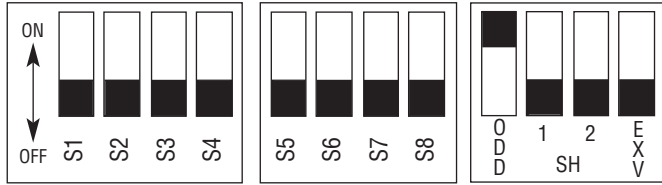

**FIGURE 25**  
**TYPICAL TWO-STAGE THERMOSTAT: (-)P17/(-)P20 HEAT PUMP WITH ELECTRIC HEAT USING A HUMIDISTAT FOR HUMIDIFICATION WITH HUMIDIFIER HAVING EXTERNAL POWER SUPPLY.**

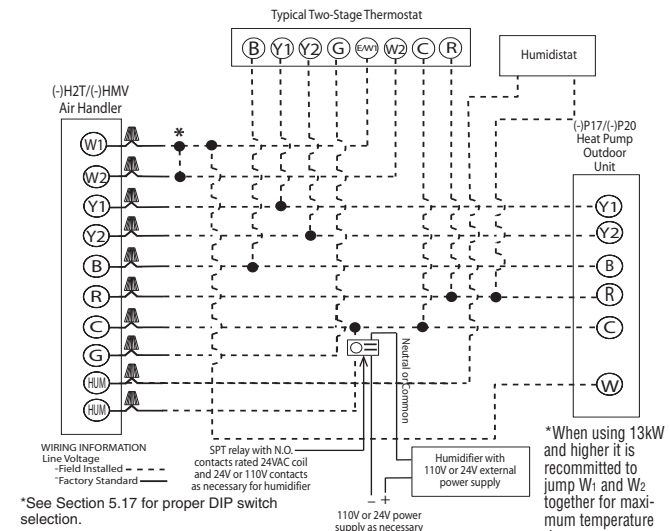

**DIP SWITCH POSITIONS**



**FIGURE 26**  
**TYPICAL TWO-STAGE THERMOSTAT: (-)P17/(-)P20 HEAT PUMP WITH ELECTRIC HEAT USING A TWO-STAGE THERMOSTAT WITH DEHUMIDIFICATION\* AND HUMIDIFICATION WITH HUMIDIFIER HAVING EXTERNAL POWER SUPPLY**

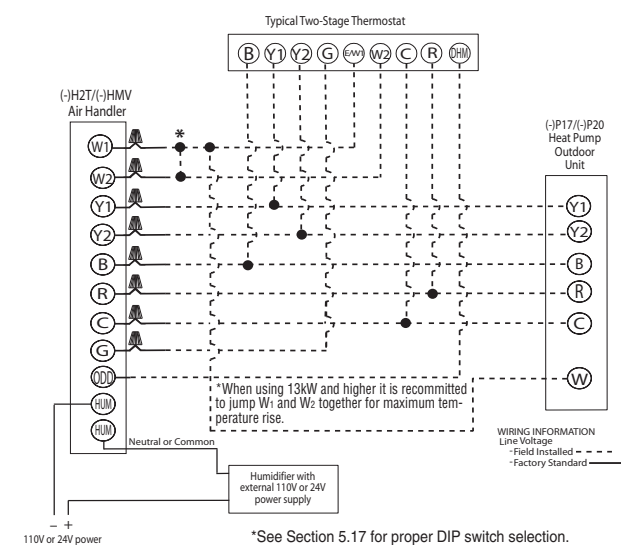

**DIP SWITCH POSITIONS**

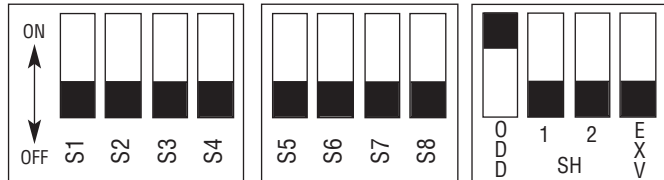

WIRE COLOR CODE			
BK - BLACK	G - GREEN	PR - PURPLE	Y - YELLOW
BR - BROWN	GY - GRAY	R - RED	
BL - BLUE	O - ORANGE	W - WHITE	

**FIGURE 27**  
**TYPICAL TWO-STAGE THERMOSTAT: (-)P17/(-)P20 HEAT PUMP WITH ELECTRIC HEAT USING A HUMIDISTAT FOR HUMIDIFICATION WITH HUMIDIFIER HAVING INTERNAL POWER SUPPLY**

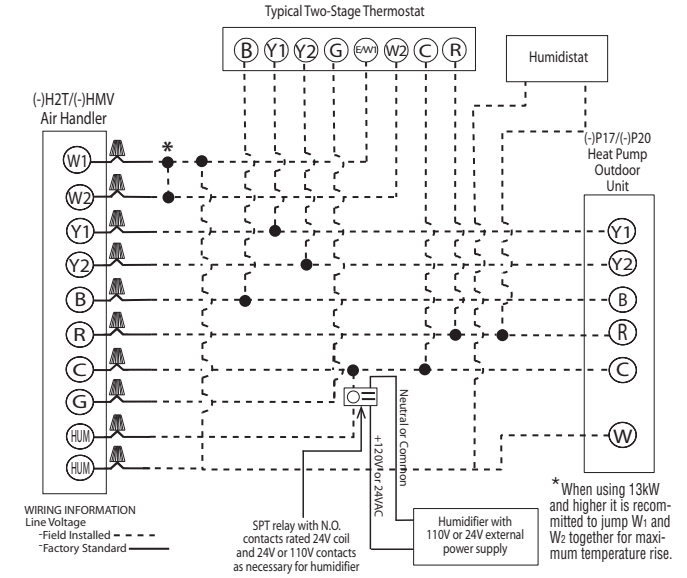

**DIP SWITCH POSITIONS**



**FIGURE 28**  
**TYPICAL TWO-STAGE THERMOSTAT: (-)P17/(-)P20 HEAT PUMP WITH ELECTRIC HEAT USING A TWO-STAGE THERMOSTAT WITH DEHUMIDIFICATION\* AND HUMIDIFICATION WITH HUMIDIFIER HAVING INTERNAL POWER SUPPLY**

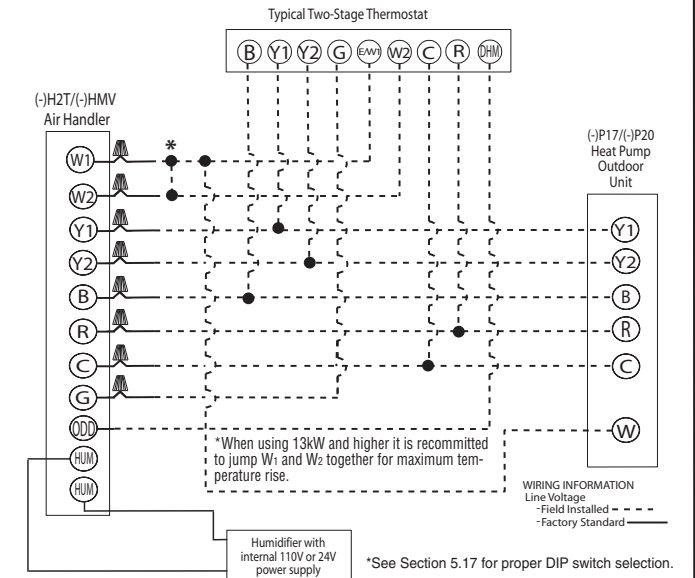

**DIP SWITCH POSITIONS**

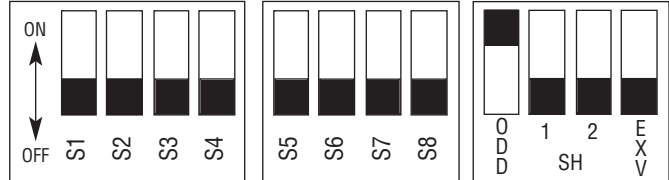

# 6.0 AIRFLOW PERFORMANCE

Airflow performance data is based on cooling performance with a coil and no filter in place. Select performance table for appropriate unit size, voltage and number of electric heaters to be used. Make sure external static applied to unit allows operation within the minimum and maximum limits shown in table below for both cooling and electric heat operation. For optimum blower performance, operate the unit in the .3 to .7 in W.C. external static range. Units with coils should be applied with a minimum of .1 in W.C. external static.

## 6.1 AIRFLOW PERFORMANCE DATA (H2T)

Air Handler (-)H2T	Outdoor Unit	Motor Speed From Factory	Blower			Motor Speed	CFM [L/s] Air Delivery / RPM / Watts (No Filter)						
			Size Motor HP	Size	# Speeds		230 VAC						
							0.1	0.2	0.3	0.4	0.5	0.6	0.7
2417SE No Heat	(-)P1724	Y1 tap 4 Y2 tap 5	1/3	10x8	5	1	651 [307]	511 [241]	307 [145]	—	—	—	—
							530	558	590	—	—	—	—
							61	47	35	—	—	—	—
						2	734 [346]	683 [322]	627 [296]	558 [263]	498 [235]	430 [203]	376 [177]
							533	591	648	705	771	825	875
							60	65	74	79	85	85	94
						3	872 [412]	826 [390]	782 [369]	735 [347]	690 [326]	637 [301]	578 [273]
							606	654	701	750	800	854	906
							91	97	103	108	115	123	122
2417SE with 13kW Heater	(-)P1724	Y1 tap 4 Y2 tap 5	1/3	10x8	5	1	589 [278]	417 [197]	181 [85]	—	—	—	—
							544	574	608	—	—	—	—
							54	41	30	—	—	—	—
						2	709 [335]	651 [307]	591 [279]	530 [250]	468 [221]	404 [191]	339 [160]
							561	621	680	737	794	850	905
							63	70	76	81	86	90	94
						3	849 [401]	806 [380]	760 [359]	712 [336]	661 [312]	608 [287]	552 [261]
							630	677	725	775	827	879	933
							94	100	107	112	117	122	126
2417SE No Heat	(-)P1724	Y1 tap 4 Y2 tap 5	1/3	10x8	5	4	918 [433]	872 [412]	829 [391]	783 [370]	738 [348]	691 [326]	638 [301]
							627	677	724	766	816	866	917
							103	111	116	122	128	137	141
						5	1047 [494]	1003 [473]	966 [456]	925 [437]	885 [418]	845 [399]	806 [380]
							692	737	780	821	860	903	944
							140	149	156	163	173	178	184
2417SE with 13kW Heater	(-)P1724	Y1 tap 4 Y2 tap 5	1/3	10x8	5	4	895 [423]	852 [402]	807 [381]	761 [359]	713 [337]	664 [314]	614 [290]
							652	698	745	793	841	891	941
							107	113	119	126	132	138	145
						5	1026 [484]	985 [465]	945 [446]	905 [427]	865 [408]	826 [390]	786 [371]
							715	758	800	842	883	923	963
							144	153	160	168	175	181	187
2421ME No Heat	(-)A1724	Y1 tap 4 Y2 tap 5	1/3	10x8	5	2	810 [382]	642 [303]	361 [170]	—	—	—	—
							477	510	555	—	—	—	—
							63	52	34	—	—	—	—
						3	939 [443]	815 [385]	666 [314]	597 [282]	547 [258]	479 [226]	433 [204]
							537	565	596	662	738	795	852
							91	83	72	77	87	90	100
2421ME with 13kW	(-)A1724	Y1 tap 4 Y2 tap 5	1/3	10x8	5	2	740 [349]	516 [243]	178 [84]	—	—	—	—
							492	531	582	—	—	—	—
							58	44	22	—	—	—	—
						3	868 [410]	746 [352]	643 [304]	561 [265]	498 [235]	456 [215]	433 [204]
							548	589	637	693	755	824	901
							85	79	77	79	85	95	109
2421ME No Heat	(-)A1724	Y1 tap 4 Y2 tap 5	1/3	10x8	5	4	838 [395]	674 [318]	423 [200]	—	—	—	—
							495	527	571	—	—	—	—
							69	60	42	—	—	—	—
						5	1038 [490]	956 [451]	931 [439]	877 [414]	842 [397]	787 [371]	749 [353]
							581	629	677	723	772	826	879
							120	122	132	138	149	157	168
2421ME with 13kW	(-)A1724	Y1 tap 4 Y2 tap 5	1/3	10x8	5	4	767 [362]	559 [264]	265 [125]	—	—	—	—
							510	548	598	—	—	—	—
							66	52	30	—	—	—	—
						5	901 [425]	855 [403]	901 [425]	855 [403]	811 [383]	770 [363]	732 [345]
							699	749	699	749	800	852	906
							135	143	135	143	152	163	174

## 6.1 AIRFLOW PERFORMANCE DATA (H2T) - continued

Air Handler (-)H2T	Outdoor Unit	Motor Speed From Factory	Blower			Motor Speed	CFM [L/s] Air Delivery / RPM / Watts (No Filter)						
			Size Motor HP	Size	# Speeds		230 VAC						
							0.1	0.2	0.3	0.4	0.5	0.6	0.7
36175SE No Heat	(-)P1736	Y1 tap 4 Y2 tap 5	1/2	10x8	5	2	1093 [516]	1050 [496]	1017 [480]	997 [471]	935 [441]	—	—
							671	725	764	809	852	—	—
							153	168	174	180	188	—	—
						3	—	—	—	—	1084 [512]	1040 [491]	1001 [472]
							—	—	—	—	896	936	971
							—	—	—	—	249	257	261
3617SE with 13kW Heater	(-)P1736	Y1 tap 4 Y2 tap 5	1/2	10x8	5	2	1068 [504]	1025 [484]	992 [468]	952 [449]	910 [429]	—	—
							711	765	804	849	892	—	—
							164	179	185	191	199	—	—
						3	—	—	—	—	1059 [500]	1015 [479]	976 [461]
							—	—	—	—	936	976	1011
							—	—	—	—	260	268	272
3617SE No Heat	(-)P1736	Y1 tap 4 Y2 tap 5	1/2	10x8	5	4	1270 [599]	1237 [584]	1199 [566]	1165 [550]	1130 [533]	—	—
							775	816	846	882	926	—	—
							237	249	259	268	277	—	—
						5	—	—	—	—	1275 [602]	1244 [587]	1211 [572]
							—	—	—	—	963	999	1029
							—	—	—	—	338	349	363
3617SE with 13kW Heater	(-)P1736	Y1 tap 4 Y2 tap 5	1/2	10x8	5	4	1245 [588]	1212 [572]	1174 [554]	1140 [538]	1105 [522]	—	—
							815	856	886	922	966	—	—
							248	260	270	279	288	—	—
						5	—	—	—	—	1250 [590]	1219 [575]	1186 [560]
							—	—	—	—	917	957	1001
							—	—	—	—	262	271	285
3621ME No Heat	(-)A1736	Y1 tap 4 Y2 tap 5	3/4	10x10	5	2	814 [384]	852 [402]	776 [366]	659 [311]	599 [283]	—	—
							582	609	690	773	812	—	—
							75	86	100	110	116	—	—
						3	—	—	1096 [517]	1043 [492]	964 [455]	909 [429]	820 [387]
							—	—	753	817	888	948	1003
							—	—	164	178	193	207	222
3621ME with 13kW Heater	(-)A1736	Y1 tap 4 Y2 tap 5	3/4	10x10	5	2	829.2165 [191]	800.77125 [378]	738.46825 [349]	642.30725 [303]	512.28825 [242]	—	—
							600	659	722	788	857	—	—
							81	94	104	113	120	—	—
						3	—	—	1072.75 [506]	1006.75 [475]	914.75 [432]	796.75 [376]	652.75 [308]
							—	—	784	852	925	1006	1092
							—	—	171	186	201	217	234
3621ME No Heat	(-)A1736	Y1 tap 4 Y2 tap 5	3/4	10x10	5	4	1053 [497]	1001 [472]	939 [443]	872 [412]	—	—	
							601	660	726	803	—	—	—
							107	117	130	143	—	—	—
						5	—	—	1305 [616]	1260 [595]	1213 [572]	1147 [541]	1107 [522]
							—	—	829	876	927	987	1028
							—	—	238	249	265	281	294
3621ME with 13kW Heater	(-)A1736	Y1 tap 4 Y2 tap 5	3/4	10x10	5	4	1027.7375 [485]	970.9875 [458]	906.7375 [428]	834.9875 [394]	—	—	
							629	692	763	844	—	—	—
							112	123	136	150	—	—	—
						5	—	—	1282.75 [605]	1236.75 [584]	1188.75 [561]	1138.75 [537]	1086.75 [513]
							—	—	852	901	904	1012	1075
							—	—	242	257	274	295	320
4821ME No Heat	(-)P1748 (-)A1748	Y1 tap 4 Y2 tap 5	1/3	10x10	5	1	865 [408]	735 [347]	648 [306]	597 [282]	538 [254]	497 [235]	435 [205]
							589	652	721	765	804	846	890
							90	86	96	102	109	114	119
						2	1104 [521]	1044 [493]	995 [470]	949 [448]	—	—	—
							683	734	795	851	—	—	—
							149	158	171	184	—	—	—
3	—	—	1399 [660]	1361 [642]	1321 [623]	1286 [607]	1242 [586]						
	—	—	940	987	1040	1075	1121						
	—	—	342	357	378	392	409						
4821ME with 13kW Heater	(-)P1748 (-)A1748	Y1 tap 4 Y2 tap 5	1/3	10x10	5	1	798.5715 [377]	693.9375 [328]	614.7315 [290]	360.9535 [265]	532.6035 [251]	529.6815 [250]	552.1875 [261]
							581	645	700	743	777	800	813
							91	96	102	111	123	1136	152
						2	1073.525 [507]	1018.625 [481]	970.725 [458]	929.825 [439]	—	—	—
							709	765	822	882	—	—	—
							153	164	177	192	—	—	—
3	—	—	1380.25 [651]	1341.25 [633]	1300.25 [614]	1257.25 [593]	1212.25 [572]						
	—	—	963	1013	1068	1130	1198						
	—	—	349	367	391	423	461						

## 6.1 AIRFLOW PERFORMANCE DATA (H2T) - continued

Air Handler (-)H2T	Outdoor Unit	Motor Speed From Factory	Blower			Motor Speed	CFM [L/s] Air Delivery / RPM / Watts (No Filter)						
			Size Motor HP	Size	# Speeds		230 VAC						
							0.1	0.2	0.3	0.4	0.5	0.6	0.7
4821ME with 13kW Heater	(-)P1748 (-)A1748	Y1 tap 4 Y2 tap 5	1/3	10x10	5	4	1206 [569]	1160 [547]	1121 [529]	1080 [510]	—	—	—
							737	768	838	896	—	—	—
							188	202	214	229	—	—	—
							—	—	1663 [785]	1626 [767]	1580 [746]	1495 [706]	1344 [634]
							—	—	1059	1098	1124	1144	1156
4821ME No Heat	(-)P1748 (-)A1748	Y1 tap 4 Y2 tap 5	1/3	10x10	5	4	1183.1875 [558]	1140.2375 [538]	1099.7875 [519]	1061.8375 [501]	—	—	—
							762	812	867	925	—	—	—
							195	208	222	236	—	—	—
							—	—	1645.625 [777]	1604.125 [757]	1553.625 [733]	1494.125 [705]	1425.925 [673]
							—	—	1080	1113	1132	1138	1131
6024ME No Heat	(-)P1760	Y1 tap 4 Y2 tap 5	1/3	11x11	5	2	1371 [647]	1304 [615]	1248 [589]	1183 [558]	—	—	—
							586	627	668	706	—	—	—
							166	175	185	195	—	—	—
							—	—	1561 [737]	1513 [714]	1460 [689]	1406 [664]	1342 [633]
							—	—	759	792	818	850	878
6024ME with 13kW Heater	(-)P1760	Y1 tap 4 Y2 tap 5	1/3	11x11	5	2	1338.375 [632]	1275.875 [602]	1214.375 [573]	1153.875 [545]	—	—	—
							607	648	687	725	—	—	—
							171	180	190	200	—	—	—
							—	—	1393.25 [658]	1312.75 [620]	1232.25 [582]	1151.75 [544]	1071.25 [506]
							—	—	776	806	829	846	857
6024ME No Heat	(-)P1760	Y1 tap 4 Y2 tap 5	1/3	11x11	5	3	—	—	311	323	333	343	351
							1375 [649]	1316 [621]	1257 [593]	1190 [562]	—	—	—
							593	632	673	713	—	—	—
							168	180	189	199	—	—	—
							—	—	1745 [824]	1709 [807]	1649 [778]	1613 [761]	1560 [736]
6024ME with 13kW Heater	(-)P1760	Y1 tap 4 Y2 tap 5	1/3	11x11	5	4	1346.4 [635]	1287 [607]	1223.6 [577]	1156.2 [546]	—	—	—
							613	652	693	734	—	—	—
							174	185	195	203	—	—	—
							—	—	1730 [816]	1682 [794]	1610 [760]	1514 [715]	1394 [658]
							—	—	829	850	880	888	884
6024ME No Heat	(-)P1760	Y1 tap 4 Y2 tap 5	1/3	11x11	5	5	—	—	409	424	426	414	390

## 6.2 AIRFLOW PERFORMANCE DATA (HMV)

Air Handler (-)HMV	Outdoor Unit	Nominal Cooling Capacity Tons	Cabinet Size	Blower		Nominal Airflow CFM**	CFM [L/s] Air Delivery / RPM / Watts (No Filter)									
				Size Motor HP	Unit Operation		External Static Pressure - In. W.C.									
							230 VAC									
							0.1	0.2	0.3	0.4	0.5	0.6	0.7	0.8	0.9	1
RHMV2417SE No Heat	(-)P1724	2	17	10 x 8 1/3	High Stage (Y2)	750	751 [354]	760 [359]	765 [361]	767 [362]	767 [362]	764 [360]	759 [358]	752 [355]	745 [351]	736 [347]
							569	652	727	797	862	923	980	1032	1078	1120
							76	94	111	129	146	163	181	198	216	233
					Int. Stage (Y1*)	540	554 [262]	552 [261]	548 [259]	544 [257]	538 [254]	532 [251]	526 [248]	521 [246]	516 [244]	513 [242]
							498	587	671	750	821	888	949	1004	1054	1097
							49	60	73	86	99	113	127	142	158	174
					Low Stage (Y1)	540	554 [262]	552 [261]	548 [259]	544 [257]	538 [254]	532 [251]	526 [248]	521 [246]	516 [244]	513 [242]
							498	587	671	750	821	888	949	1004	1054	1097
							49	60	73	86	99	113	127	142	158	174
RHMV2417SE with 13kW Heater	(-)P1724	2	17	10 x 8 1/3	High Stage (Y2)	750	756 [357]	763 [360]	766 [362]	767 [362]	765 [361]	762 [359]	756 [357]	749 [353]	741 [349]	732 [345]
							609	690	763	831	894	952	1006	1056	1100	1139
							85	103	120	137	155	172	190	207	224	242
					Int. Stage (Y1*)	540	553 [261]	550 [260]	546 [258]	541 [255]	535 [253]	529 [250]	523 [247]	518 [245]	514 [243]	512 [242]
							543	630	711	787	855	920	977	1030	1076	1117
							55	67	79	92	106	120	135	150	166	182
					Low Stage (Y1)	540	553 [261]	550 [260]	546 [258]	541 [255]	535 [253]	529 [250]	523 [247]	518 [245]	514 [243]	512 [242]
							543	630	711	787	855	920	977	1030	1076	1117
							55	67	79	92	106	120	135	150	166	182
RHMV2421ME No Heat	(-)A2024	2	21	10 x 8 1/3	High Stage (Y2)	835	859 [405]	873 [412]	882 [416]	887 [419]	889 [419]	888 [419]	885 [418]	881 [416]	877 [414]	874 [413]
							554	634	706	776	841	900	955	1004	1049	1088
							85	106	126	146	167	187	208	228	249	269
					Int. Stage (Y1*)	460	441 [208]	453 [214]	464 [219]	472 [223]	479 [226]	482 [228]	484 [228]	482 [227]	477 [225]	469 [221]
							625	735	837	929	1012	1084	1151	1204	1251	1287
							90	101	113	125	137	149	162	174	187	201
					Low Stage (Y1)	310	291 [137]	303 [143]	314 [148]	322 [152]	329 [155]	332 [157]	334 [157]	332 [157]	327 [154]	319 [150]
							381	492	593	686	769	841	907	961	1008	1044
							21	33	44	56	68	80	93	105	119	132

## 6.2 AIRFLOW PERFORMANCE DATA (HMV) - continued

Air Handler (-)H MV	Outdoor Unit	Nominal Cooling Capacity Tons	Cabinet Size	Blower		Nominal Airflow CFM**	CFM [L/s] Air Delivery / RPM / Watts (No Filter)									
				Size Motor HP	Unit Operation		External Static Pressure - In. W.C. 230 VAC									
							0.1	0.2	0.3	0.4	0.5	0.6	0.7	0.8	0.9	1
RHMV2421ME with 13kW Heater	(-)A2024	2	21	10 x 8 1/3	High Stage (Y2)	835	867 [409]	878 [415]	885 [418]	888 [419]	888 [419]	886 [418]	883 [417]	879 [415]	876 [413]	874 [412]
							594	672	742	809	872	928	981	1027	1069	1106
							95	116	136	156	177	197	218	238	259	279
					Int. Stage (Y1*)	460	447 [211]	459 [217]	468 [221]	476 [225]	481 [227]	483 [228]	483 [228]	480 [226]	473 [223]	463 [219]
							681	787	884	972	1050	1118	1179	1228	1270	1302
							96	107	119	131	143	155	168	180	194	207
Low Stage (Y1)	310	297 [140]	309 [146]	318 [150]	326 [154]	331 [156]	333 [157]	333 [157]	330 [156]	323 [153]	313 [148]					
		438	544	641	728	807	874	936	985	1027	1059					
		27	38	50	62	74	86	99	112	125	139					
RHMV2421HE No Heat	(-)P2024	2	21	10 x 10 1/2	High Stage (Y2)	855	861 [406]	872 [411]	876 [413]	875 [413]	870 [410]	860 [406]	846 [399]	830 [392]	811 [383]	790 [373]
							485	568	649	727	805	876	941	996	1045	1082
							928	938	943	942	936	927	913	897	878	856
					Int. Stage (Y1*)	580	615 [290]	626 [296]	629 [297]	625 [295]	616 [291]	602 [284]	588 [277]	570 [269]	554 [261]	540 [255]
							414	548	657	739	806	861	907	955	1005	1064
							31	53	74	93	110	127	143	160	177	194
		Low Stage (Y1)	325	344 [162]	334 [158]	325 [153]	315 [148]	305 [144]	295 [139]	285 [135]	276 [130]	268 [127]	262 [123]			
				430	539	633	715	785	851	911	966	1020	1074			
				25	36	47	58	69	81	93	106	119	133			
	2	21	10 x 10 1/2	High Stage (Y2)	825	837 [395]	855 [403]	860 [406]	857 [404]	846 [399]	830 [392]	813 [384]	795 [375]	781 [369]	772 [364]	
						517	622	714	798	872	941	996	1047	1088	1122	
						819	837	843	839	829	812	796	778	764	755	
				Int. Stage (Y1*)	665	688 [325]	703 [332]	707 [334]	702 [331]	691 [926]	675 [319]	658 [311]	641 [303]	627 [296]	619 [292]	
						428	554	655	739	810	870	920	968	1014	1061	
						34	60	83	104	124	143	160	178	197	216	
Low Stage (Y1)	565	581 [274]	575 [271]	569 [268]	563 [266]	557 [263]	552 [261]	548 [258]	544 [257]	542 [256]	540 [255]					
		620	736	834	916	986	1048	1104	1157	1211	1269					
		88	102	116	129	143	157	171	186	203	222					



## 6.2 AIRFLOW PERFORMANCE DATA (HMV) - continued

Air Handler (-)H MV	Outdoor Unit	Nominal Cooling Capacity Tons	Cabinet Size	Blower		Nominal Airflow CFM**	CFM [L/s] Air Delivery / RPM / Watts (No Filter)										
				Size Motor HP	Unit Operation		External Static Pressure - In. W.C. 230 VAC										
							0.1	0.2	0.3	0.4	0.5	0.6	0.7	0.8	0.9	1	
RHMV2421HE with 13kW Heater	(-)P2024	2	21	10 x 10 1/2	High Stage (Y2)	855	867 [409]	874 [413]	876 [414]	873 [412]	865 [408]	853 [403]	838 [396]	821 [388]	801 [378]	778 [367]	
							525	608	689	766	841	910	971	1021	1064	1096	
							934	941	943	940	932	920	905	888	868	845	
					Int. Stage (Y1*)	580	622 [293]	629 [297]	628 [296]	621 [293]	610 [288]	595 [281]	579 [273]	562 [265]	547 [258]	534 [252]	
							485	604	701	774	834	886	930	979	1033	1098	
							42	64	84	102	119	136	151	168	185	202	
	Low Stage (Y1)	325	339 [160]	330 [156]	320 [151]	310 [146]	300 [142]	290 [137]	281 [132]	272 [129]	265 [125]	258 [122]					
			486	588	675	752	818	881	939	993	1047	1103					
			30	41	52	63	75	87	99	112	126	140					
						High Stage (Y2)	825	847 [400]	859 [405]	859 [406]	852 [402]	839 [396]	821 [388]	804 [379]	787 [372]	776 [366]	770 [363]
								571	670	758	837	906	971	1022	1069	1106	1137
								830	841	842	835	821	804	787	770	758	753
Int. Stage (Y1*)						665	697 [329]	706 [333]	705 [333]	697 [329]	683 [323]	667 [315]	650 [307]	634 [299]	622 [294]	617 [291]	
							492	608	700	776	841	896	944	991	1037	1086	
							47	72	94	114	133	152	169	188	206	226	
Low Stage (Y1)	565	578 [273]	572 [270]	566 [267]	560 [264]	555 [262]	550 [259]	546 [258]	543 [256]	541 [255]	540 [255]						
		680	787	877	952	1017	1076	1131	1184	1240	1301						
		95	109	123	136	149	164	179	195	212	232						
RHMV3617SE No Heat	(-)P1736	3	17	10 x 8 1/3	High Stage (Y2)	1235	1228 [580]	1222 [577]	1222 [577]	1226 [579]	1231 [581]	1234 [582]	1232 [582]	1223 [577]	1204 [568]	1172 [553]	
							758	817	871	922	971	1018	1060	1101	1139	1174	
							202	231	257	283	308	332	354	376	397	416	
					Int. Stage (Y1*)	660	666 [314]	679 [320]	685 [323]	687 [324]	686 [324]	681 [322]	675 [318]	667 [315]	658 [311]	650 [307]	
							472	558	629	700	766	828	885	937	984	1028	
							44	61	78	96	113	130	148	165	182	200	
Low Stage (Y1)	660	666 [314]	679 [320]	685 [323]	687 [324]	686 [324]	681 [322]	675 [318]	667 [315]	658 [311]	650 [307]						
		472	553	629	700	766	828	885	937	984	1028						
		44	61	78	96	113	130	148	165	182	200						
RHMV3617SE with 13kW Heater	(-)P1736	3	17	10 x 8 1/3	High Stage (Y2)	1235	1224 [578]	1221 [576]	1224 [578]	1229 [580]	1233 [582]	1234 [582]	1229 [580]	1215 [574]	1189 [561]	1150 [543]	
							787	845	897	947	995	1040	1081	1120	1157	1191	
							216	244	270	295	320	343	365	386	407	426	
					Int. Stage (Y1*)	660	673 [318]	683 [322]	687 [324]	687 [324]	684 [323]	678 [320]	671 [317]	663 [313]	654 [309]	646 [305]	
							513	591	665	734	798	857	911	961	1007	1048	
							52	70	87	104	122	139	156	174	191	209	
Low Stage (Y1)	660	673 [318]	683 [322]	687 [324]	687 [324]	684 [323]	678 [320]	671 [317]	663 [313]	654 [309]	646 [305]						
		513	591	665	734	798	857	911	961	1007	1048						
		52	70	87	104	122	139	156	174	191	209						

## 6.1 AIRFLOW PERFORMANCE DATA (HMV) - continued

Air Handler (-)H MV	Outdoor Unit	Nominal Cooling Capacity Tons	Cabinet Size	Blower		Nominal Airflow CFM**	CFM [L/s] Air Delivery / RPM / Watts (No Filter)											
				Size Motor HP	Unit Operation		External Static Pressure - In. W.C. 230 VAC											
							0.1	0.2	0.3	0.4	0.5	0.6	0.7	0.8	0.9	1		
RHMV6021SE No Heat	(-)P2048 Cool	4	21	10 x 10 1/2	High Stage (Y2)	1660	1655 [781]	1655 [781]	1676 [791]	1704 [804]	1739 [821]	1763 [832]	1771 [836]	1748 [825]	1689 [797]	1582 [746]		
							796	872	953	1018	1085	1139	1184	1228	1257	1279		
							298	372	449	509	569	615	651	682	698	705		
							Int. Stage (Y1*)	890	896 [423]	904 [427]	902 [426]	892 [421]	878 [414]	861 [407]	844 [398]	829 [391]	817 [385]	812 [383]
									588	688	779	860	931	991	1045	1087	1123	1148
									104	129	153	175	197	216	235	253	271	287
	Low Stage (Y1)	630			644 [304]	632 [298]	622 [294]	611 [289]	601 [284]	589 [278]	574 [271]	554 [262]	530 [250]	499 [236]				
					446	536	616	697	765	826	881	929	969	1003				
					37	57	76	96	114	131	148	164	179	194				
	(-)P2048 Heat	4			High Stage (Y2)	1600	1576 [744]	1583 [747]	1603 [757]	1641 [774]	1666 [786]	1657 [782]	1694 [799]	1678 [792]	1702 [802]	1615 [762]		
							794	886	917	969	1040	1120	1169	1225	1275	1301		
							291	353	361	419	489	553	601	660	715	693		
							Int. Stage (Y1*)	855	861 [407]	869 [410]	867 [409]	857 [405]	843 [398]	826 [390]	809 [382]	794 [375]	782 [369]	777 [367]
									560	661	751	833	904	964	1017	1060	1096	1121
									90	114	138	161	182	201	221	238	256	272
	Low Stage (Y1)	530			577 [273]	533 [251]	492 [232]	454 [214]	—	—	—	—	—	—				
					442	542	629	698	—	—	—	—	—	—				
					39	51	662	72	—	—	—	—	—	—				
	(-)A2048	4			High Stage (Y2)	1565	1541 [727]	1550 [732]	1572 [742]	1595 [753]	1620 [765]	1643 [776]	1657 [782]	1656 [782]	1636 [772]	1594 [752]		
							776	841	911	969	1027	1088	1147	1195	1248	1295		
							261	314	371	420	469	521	572	616	664	707		
							Int. Stage (Y1*)	835	841 [397]	849 [401]	847 [400]	837 [395]	823 [388]	806 [381]	789 [372]	774 [365]	762 [360]	757 [357]
									545	645	735	817	888	948	1002	1044	1080	1105
									82	106	130	153	174	193	213	230	248	264
Low Stage (Y1)	595	628 [297]	585 [276]	555 [262]	533 [252]	518 [245]	507 [239]	496 [234]	483 [228]	463 [219]	435 [205]							
		472	561	641	718	787	849	907	958	1003	1042							
		47	61	74	89	103	118	134	149	166	182							
(-)P2036	3	High Stage (Y2)	1235	1207 [570]	1233 [582]	1260 [594]	1283 [605]	1301 [614]	1313 [620]	1315 [620]	1303 [615]	1277 [603]	1233 [582]					
				655	736	817	891	964	1035	1097	1167	1277	1285					
				152	190	230	270	310	353	393	440	484	529					
				Int. Stage (Y1*)	660	674 [318]	662 [312]	652 [308]	641 [303]	631 [298]	619 [292]	604 [285]	584 [276]	560 [264]	529 [250]			
						472	562	642	723	791	852	907	955	995	1029			
						45	65	84	104	122	139	156	172	187	202			
Low Stage (Y1)	470	517 [244]	473 [223]	432 [204]	394 [186]	—	—	—	—	—	—							
		442	542	629	698	—	—	—	—	—	—							
		39	51	62	72	—	—	—	—	—	—							
(-)P2036	3	High Stage (Y2)	1235	1207 [570]	1233 [582]	1260 [594]	1283 [605]	1301 [614]	1313 [620]	1315 [620]	1303 [615]	1277 [603]	1233 [582]					
				655	736	817	891	964	1035	1097	1167	1277	1285					
				152	190	230	270	310	353	393	440	484	529					
				Int. Stage (Y1*)	660	674 [318]	662 [312]	652 [308]	641 [303]	631 [298]	619 [292]	604 [285]	584 [276]	560 [264]	529 [250]			
						472	562	642	723	791	852	907	955	995	1029			
						45	65	84	104	122	139	156	172	187	202			
Low Stage (Y1)	411	424 [200]	361 [170]	323 [153]	282 [133]	0 [0]	0 [0]	0 [0]	0 [0]	0 [0]	0 [0]							
		459	550	632	702	—	—	—	—	—	—							
		36	44	53	63	—	—	—	—	—	—							

## 6.1 AIRFLOW PERFORMANCE DATA (HMMV) - continued

Air Handler (-)HMMV	Outdoor Unit	Nominal Cooling Capacity Tons	Cabinet Size	Blower		Nominal Airflow CFM**	CFM [L/s] Air Delivery / RPM / Watts (No Filter)										
				Size Motor HP	Unit Operation		External Static Pressure - In. W.C.										
							230 VAC										
							0.1	0.2	0.3	0.4	0.5	0.6	0.7	0.8	0.9	1	
RHMV6021SE with 13kW Heater	(-)P2048 Cool	4	21	10 x 10 3/4	High Stage (Y2)	1660	1653 [780]	1663 [785]	1690 [798]	1721 [812]	1753 [827]	1770 [835]	1766 [833]	1723 [813]	1641 [775]	1507 [711]	
							841	913	990	1051	1114	1164	1205	1244	1269	1286	
							342	411	483	539	594	635	666	691	703	705	
					Int. Stage (Y1*)	890	902 [425]	904 [427]	898 [424]	886 [418]	870 [410]	853 [402]	836 [394]	822 [388]	813 [384]	812 [383]	
							639	734	820	897	964	1019	1068	1106	1137	1158	
							117	141	164	186	207	226	245	262	279	294	
	Low Stage (Y1)	630	638 [301]	627 [296]	617 [291]	606 [286]	595 [281]	582 [274]	565 [266]	543 [256]	516 [243]	481 [227]					
			492	578	655	732	797	854	905	950	987	1017					
			47	67	85	105	122	139	156	172	187	201					
	(-)P2048 Heat	4	21	10 x 10 3/4	10 x 10 3/4	High Stage (Y2)	1600	1579 [745]	1594 [752]	1619 [764]	1643 [775]	1667 [787]	1686 [796]	1693 [799]	1685 [795]	1653 [780]	1597 [754]
								829	893	962	1019	1076	1135	1193	1240	1291	1336
								311	363	420	468	516	568	618	661	708	751
						Int. Stage (Y1*)	855	867 [409]	869 [410]	863 [407]	851 [401]	835 [394]	818 [386]	801 [378]	787 [372]	778 [367]	777 [367]
								611	707	793	870	936	992	1040	1078	1110	1130
								102	126	149	171	192	211	230	247	264	280
	Low Stage (Y1)	530	554 [261]	512 [242]	473 [223]	433 [204]	—	—	—	—	—	—					
			495	587	666	727	—	—	—	—	—	—					
			45	57	67	77	—	—	—	—	—	—					
	(-)A2048	4	21	10 x 10 3/4	10 x 10 3/4	High Stage (Y2)	1565	1544 [729]	1559 [736]	1584 [748]	1608 [759]	1632 [770]	1651 [779]	1658 [783]	1650 [779]	1618 [764]	1562 [737]
								810	874	943	1000	1057	1116	1173	1221	1272	1317
								288	341	397	445	494	545	596	638	686	728
						Int. Stage (Y1*)	835	847 [400]	849 [401]	843 [398]	831 [392]	815 [384]	798 [376]	781 [368]	767 [362]	758 [358]	757 [357]
								595	691	777	854	920	976	1025	1063	1094	1114
								94	118	141	163	184	203	222	239	256	272
Low Stage (Y1)	595	605 [285]	568 [268]	543 [256]	525 [248]	513 [242]	502 [237]	490 [231]	474 [224]	450 [212]	416 [196]						
		517	602	679	753	819	879	933	981	1023	1059						
		54	67	81	96	111	126	142	157	174	191						
(-)P2036	3	21	10 x 10 3/4	10 x 10 3/4	High Stage (Y2)	1235	1220 [576]	1246 [588]	1272 [600]	1293 [610]	1308 [617]	1315 [621]	1311 [619]	1292 [610]	1257 [593]	1204 [568]	
							696	776	855	928	999	1069	1130	1197	1257	1313	
							171	210	250	290	331	374	414	462	506	552	
					Int. Stage (Y1*)	660	668 [315]	657 [310]	647 [305]	636 [300]	625 [295]	612 [289]	595 [281]	573 [270]	546 [257]	511 [241]	
							518	604	681	758	823	880	931	976	1013	1043	
							55	75	93	113	130	147	164	180	195	209	
Low Stage (Y1)	470	494 [233]	452 [213]	413 [195]	373 [176]	—	—	—	—	—	—						
		495	587	666	727	—	—	—	—	—	—						
		45	57	67	77	—	—	—	—	—	—						
(-)P2036	3	21	10 x 10 3/4	10 x 10 3/4	High Stage (Y2)	1235	1220 [576]	1246 [588]	1272 [600]	1293 [610]	1308 [617]	1315 [621]	1311 [619]	1292 [610]	1257 [593]	1204 [568]	
							696	776	855	928	999	1069	1130	1197	1257	1313	
							171	210	250	290	331	374	414	462	506	552	
					Int. Stage (Y1*)	660	668 [315]	657 [310]	647 [305]	636 [300]	625 [295]	612 [289]	595 [281]	573 [270]	546 [257]	511 [241]	
							518	604	681	758	823	880	931	976	1013	1043	
							55	75	93	113	130	147	164	180	195	209	
Low Stage (Y1)	411	387 [183]	341 [161]	305 [144]	250 [118]	—	—	—	—	—	—						
		507	592	669	733	—	—	—	—	—	—						
		40	48	58	68	—	—	—	—	—	—						
RHMV6024ME No Heat	(-)A2060/ (-)P2060	5	24	11 x 11 3/4	High Stage (Y2)	1670	1640 [774]	1673 [790]	1695 [800]	1710 [807]	1712 [808]	1703 [804]	1681 [794]	1647 [777]	1599 [755]	1539 [726]	
							609	681	744	810	858	915	962	1002	1038	1068	
							230	296	356	421	471	534	589	641	690	736	
					Int. Stage (Y1*)	755	773 [365]	779 [368]	779 [368]	773 [365]	763 [360]	751 [354]	737 [348]	723 [341]	710 [335]	699 [330]	
							406	480	549	614	674	729	779	826	867	903	
							50	70	91	113	135	158	181	205	229	254	
Low Stage (Y1)	500	538 [254]	497 [235]	430 [203]	—	—	—	—	—	—	—						
		371	462	536	—	—	—	—	—	—	—						
		35	49	59	—	—	—	—	—	—	—						
RHMV6024ME with 13kW Heater	(-)A2060/ (-)P2060	5	24	11 x 10 3/4	High Stage (Y2)	1670	1657 [782]	1686 [796]	1704 [804]	1712 [808]	1710 [807]	1694 [800]	1666 [786]	1625 [767]	1570 [741]	1503 [709]	
							645	714	775	838	884	938	983	1020	1054	1081	
							262	327	387	450	500	561	615	665	714	758	
					Int. Stage (Y1*)	755	777 [367]	780 [368]	776 [366]	769 [363]	757 [357]	744 [351]	730 [345]	716 [338]	704 [332]	695 [328]	
							444	515	582	644	702	755	803	847	886	919	
							60	81	102	124	146	169	192	217	242	267	
Low Stage (Y1)	500	520 [245]	468 [221]	380 [180]	—	—	—	—	—	—	—						
		418	500	569	—	—	—	—	—	—	—						
		42	54	65	—	—	—	—	—	—	—						

## 7.0 DUCTWORK

Field ductwork must comply with the National Fire Protection Association NFPA 90A, NFPA 90B and any applicable local ordinance.

### WARNING

**Do not, under any circumstances, connect return ductwork to any other heat producing device such as fireplace insert, stove, etc. Unauthorized use of such devices may result in fire, carbon monoxide poisoning, explosion, personal injury or property damage.**

Sheet metal ductwork run in unconditioned spaces must be insulated and covered with a vapor barrier. Fibrous ductwork may be used if constructed and installed in accordance with SMACNA Construction Standard on Fibrous Glass Ducts. Ductwork must comply with National Fire Protection Association as tested by U/L Standard 181 for Class I Air Ducts. Check local codes for requirements on ductwork and insulation.

- Duct system must be designed within the range of external static pressure the unit is designed to operate against. It is important that the system airflow be adequate. Make sure supply and return ductwork, grills, special filters, accessories, etc. are accounted for in total resistance. See airflow performance tables in this manual.
- Design the duct system in accordance with “ACCA” Manual “D” Design for Residential Winter and Summer Air Conditioning and Equipment Selection. Latest editions are available from: “ACCA” Air Conditioning Contractors of America, 1513 16th Street, N.W., Washington, D.C. 20036. If duct system incorporates **flexible air duct**, be sure **pressure drop** information (straight length plus all turns) shown in “ACCA” Manual “D” is accounted for in system.
- Supply plenum is attached to the 3/4” duct flanges supplied with the unit. Attach flanges around the blower outlet.

**IMPORTANT:** If an elbow is included in the plenum close to the unit, it must not be smaller than the dimensions of the supply duct flange on the unit.

- **IMPORTANT:** The front flange on the return duct if connected to the blower casing must not be screwed into the area where the power wiring is located. Drills or sharp screw points can damage insulation on wires located inside unit.
- Secure the supply and return ductwork to the unit flanges, using proper fasteners for the type of duct used and tape the duct-to-unit joint as required to prevent air leaks.

## 8.0 REFRIGERANT CONNECTIONS

Keep the coil connections sealed until refrigerant connections are to be made. See the Installation Instructions for the outdoor unit for details on line sizing, tubing installation, and charging information.

Coil is shipped with a low (5 - 10 PSIG) pressure charge of dry nitrogen. Evacuate the system before charging with refrigerant.

Install refrigerant tubing so that it does not block service access to the front of the unit.

Nitrogen should flow through the refrigerant lines while brazing.

**Make sure to protect the EXV pressure transducer, vapor thermister, copper to aluminum joint, and service valves from overheating by use of wet rag or some type of shielding. Double tip torches are not recommended.**

Use a brazing shield to protect the cabinet’s paint from being damaged by torch flames.

After the refrigerant connections are made, seal the gap around the connections with pressure sensitive gasket. If necessary, cut the gasket into two pieces for a better seal.

### 8.1 ELECTRONIC EXPANSION

The (-)H2T and (-)H MV EcoNet™ enabled air handlers are equipped with an electronic refrigerant expansion device otherwise known as EXVs. One of the biggest advantages of an EXV is the control can intelligently change the EXV position based on system demands other than just suction line temperature. By the measurement of the suction pressure via the vapor line pressure transducer (factory installed) and the vapor line thermister (field connected to the vapor line, but factory provided within the air handler) the EcoNet™ enabled air handler control calculates the suction superheat at the indoor coil. This calculation permits the air handler control to make decisions for when to open and close the electronic expansion valve for the purpose of maintaining a predetermined suction superheat. The electronic valve is equipped with a 4-pole removable external stator, and inlet and outlet Chatleff fittings for optimal serviceability. These valves also have an internal check valve to provide heat pump compatibility. When operating in

heating mode, the air handler control will open the electronic valve completely to permit the check valve to operate and maximize reverse refrigerant flow.

## 8.2 EXV VAPOR LINE THERMISTER

**IMPORTANT:** DO NOT perform any brazing with the vapor line thermister attached to any line. After brazing operations have been completed, clamp the vapor line thermister securely on the vapor line at the 10 to 2 o'clock position with the clip provided on the thermister. Insulate the vapor line thermister and vapor line with the provided pressure sensitive insulation (size 4" x 7") and secure with provided wire ties.

**IMPORTANT:** Vapor line thermister should be located on a horizontal section of vapor line, just outside of coil box. The copper thermister must never be placed on any aluminum tube as this will result in galvanic corrosion and eventual failure of the aluminum tube.

**IMPORTANT:** Never place the thermister on the heat effected zone near the braze connection, but it should be located within 6" of the indoor unit.

**FIGURE 29**  
THERMISTER LOCATION

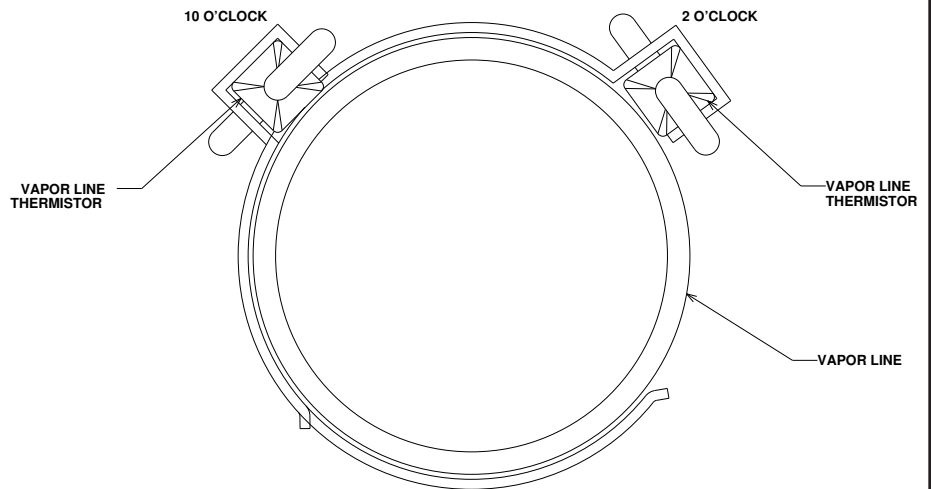

**FIGURE 30**  
THERMISTER LOCATION

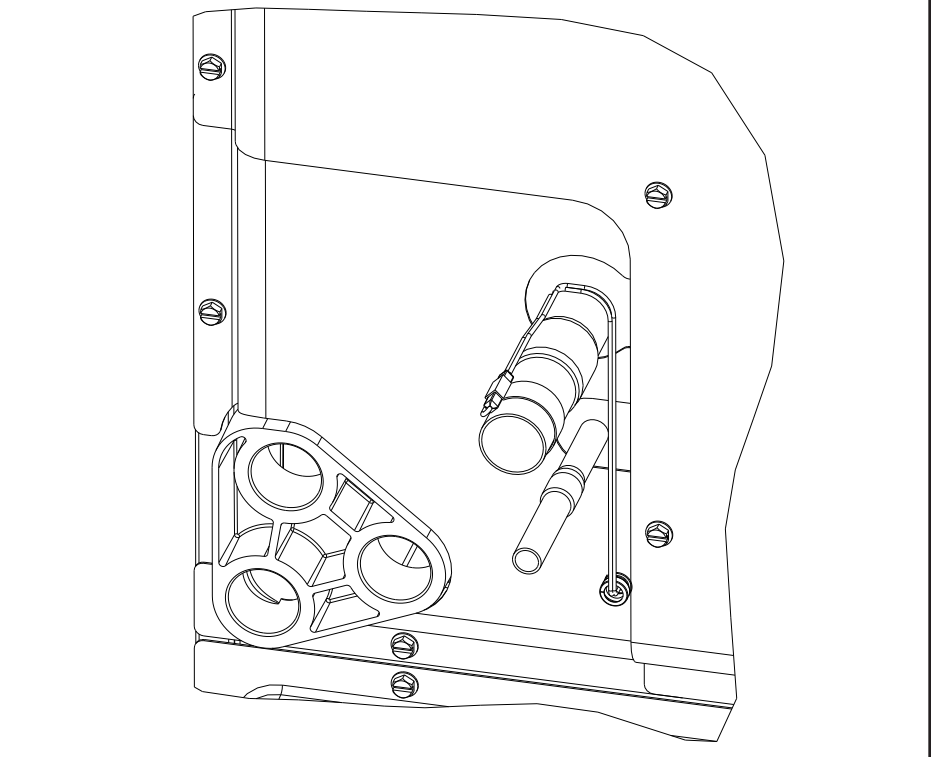

### 8.3 FACTORY PROGRAMMED SUPERHEAT

The EcoNet™ air handler control is pre-programmed with the optimum superheat setting for each air handler. The following settings will be assigned from the factory and active at time of install.

Air Handler	Outdoor Unit	Superheat (°F)	Dipswitch Settings	
			1	2
RH2T2417SE	RP1724	6	OFF	OFF
RHMV/RH2T2421ME	RA1724, RA2024, RP2024	6	OFF	OFF
RH2T3617SE	RP1736	6	OFF	OFF
RH2T3621ME	RA1736	8	OFF	OFF
RH2T4821ME	RA1748, RP1748	6	OFF	OFF
RHMV/RH2T6021SE	RA2036, RA2048, RA2060, RP1760 RP2036, RP2048, RP2060	6	OFF	OFF
RH2T6024ME	RA1760	6	OFF	OFF

### 8.4 SUPERHEAT OFFSET DIP SWITCH SETTINGS

Although the factory programmed superheat set point is considered to be the most efficient set point for each air handler, installation conditions can drastically effect the measurement of superheat by the air handler control. For this reason the following dip switch settings have been provided to enable flexibility for various installation conditions.

Superheat Offset Selection Profile	Off Set from Programmed Setting (°F)
A	0
B	-4
C	-2
D	+2

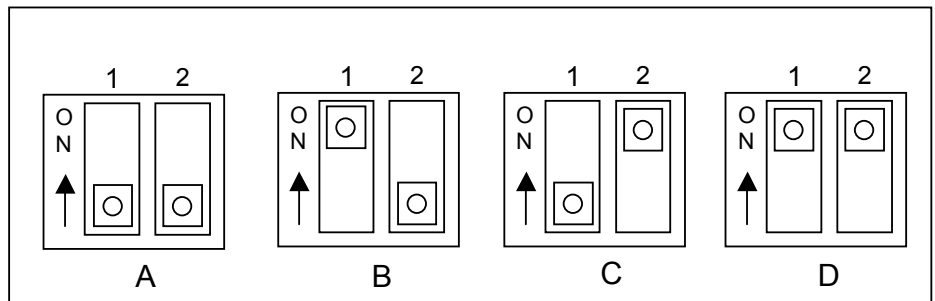

### 8.5 EXV STEP DIP SWITCH

The EXV dip switch has an optional 500 or 1600 steps setting. This dipswitch should currently be in the 500 step position only. Rheem does not currently supply 1600 step EXV's. The dipswitch makes the control forward compatible with a 1600 step EXV for possible future use.

### 8.6 DIAGNOSTICS

Two LED's are supplied to aid in troubleshooting. The green LED indicates the control is attempting to open the EXV and the amber LED indicates it is attempting to close the EXV. Additionally, it is possible to feel the coil on the EXV pulse when the control is attempting to change the EXV position.

### 8.7 CONDENSATE DRAIN TUBING

Consult local codes or ordinances for specific requirements.

**IMPORTANT:** When making drain fitting connections to the drain pan, use a thin layer of Teflon paste, silicone or Teflon tape and install hand tight.

**IMPORTANT:** When making drain fitting connections to drain pan, do not overtighten. Overtightening fittings can split pipe connections on the drain pan.

- Install drain lines so they do not block service access to front of the unit. Minimum clearance of 24 inches is required for filter, coil or blower removal and service access.
- Make sure unit is level or pitched slightly toward primary drain connection so that water will drain completely from the pan. (See Figure 31.)
- Do not reduce drain line size less than connection size provided on condensate drain pan.
- All drain lines must be pitched downward away from the unit a minimum of 1/8" per foot of line to ensure proper drainage.

**FIGURE 31**  
**CONDENSATE DRAIN TRAP**

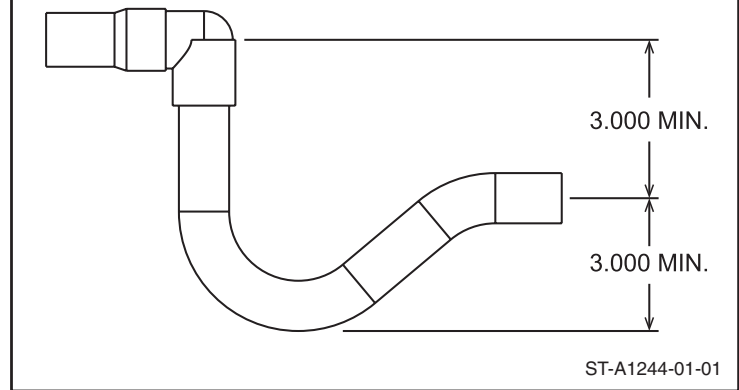

- Do not connect condensate drain line to a closed or open sewer pipe. Run condensate to an open drain or outdoors.
- The drain line should be insulated where necessary to prevent sweating and damage due to condensate forming on the outside surface of the line.
- Make provisions for disconnecting and cleaning of the primary drain line should it become necessary. Install a 3 in. trap in the primary drain line as close to the unit as possible. Make sure that the top of the trap is below connection to the drain pan to allow complete drainage of pan (See Figure 31).
- Auxiliary drain line should be run to a place where it will be noticeable if it becomes operational. Occupant should be warned that a problem exists if water should begin running from the auxiliary drain line.
- Plug the unused drain connection with the plugs provided in the parts bag, using a thin layer of teflon paste, silicone or teflon tape to form a water tight seal.
- Test condensate drain pan and drain line after installation is complete. Pour water into drain pan, enough to fill drain trap and line. Check to make sure drain pan is draining completely, no leaks are found in drain line fittings, and water is draining from the termination of the primary drain line.

## 8.8 DUCT FLANGES

Field-installed duct flanges (4 pieces) are shipped with units. Install duct flanges as needed on top of the unit. (See Figure 3.)

## 9.0 AIR FILTER (not factory-installed)

- External filter or other means of filtration is required. Units should be sized for a maximum of 300 feet/min. air velocity or that recommended for the type filter installed.

Filter application and placement are critical to airflow, which may affect the heating and cooling system performance. Reduced airflow can shorten the life of the system's major components, such as motor, limits, elements, heat relays, evaporator coil or compressor. Consequently, we recommend that the return air duct system have only one filter location. For systems with a return air filter grill or multiple filter grills, can have a filter installed at each of the return air openings.

If high efficiency filters or electronic air cleaners are used in the system, it is important that the airflow is not reduced to maximize system performance and life. Always verify that the system's airflow is not impaired by the filtering system that has been installed, by performing a temperature rise and temperature drop test.

**IMPORTANT: DO NOT DOUBLE FILTER THE RETURN AIR DUCT SYSTEM. DO NOT FILTER THE SUPPLY AIR DUCT SYSTEM.**

### **⚠ WARNING**

**Do not operate the system without filters. A portion of the dust entrained in the air may temporarily lodge in the duct runs and at the supply registers. Any circulated dust particles could be heated and charred by contact with the air handler elements. This residue could soil ceilings, walls, drapes, carpets and other articles in the house.**

**Soot damage may occur with filters in place, when certain types of candles, oil lamps or standing pilots are burned.**

## 10.0 SEQUENCE OF OPERATION

### 10.1 COOLING (COOLING ONLY OR HEAT PUMP)

- In a serial communicating network:

When the thermostat “calls for cooling,” a cooling command is sent via the serial network to the air handler and outdoor unit.
- Using conventional 24VAC thermostat wiring:

When the thermostat “calls for cooling,” the circuit between R and Y is completed. A “call for cooling” causes:

  - 1) The blower to start.
  - 2) The outdoor unit control requests to start the compressor.
  - 3) The outdoor fan motor to start.

### 10.2 HEATING (ELECTRIC HEAT ONLY)

- In a serial communicating network:

When the thermostat “calls for heat,” a heating command is sent via the serial network to the air handler.
- Using conventional 24VAC thermostat wiring:

When the thermostat “calls for heat,” the circuit between R and W is completed. A “call for heat” causes:

  - 1) The heater sequencer (HR1) energizes.
  - 2) A timed delay begins.
  - 3) The indoor blower motor (IBM) starts.
  - 4) The heating elements (HE) energize.

### 10.3 HEATING (HEAT PUMP)

- In serial communications network:

When the thermostat “calls for heat,” a heating command is sent via the serial network to the air handler and outdoor unit.
- Using conventional 24VAC thermister wiring:

When the thermostat “calls for heat,” the circuits between R and B, R and Y1/Y2 and R and G are completed. Circuit R and B energizes the reversing valve (RV) switching it to the heating position (remains energized as long as selector switch is in “heat” position). Circuit R and Y1/Y2 sent to the outdoor unit control initiates a request to start the compressor (COMP). Circuit R and G initiates the request to start the indoor blower motor (IBM).
- If the room temperature should continue to fall, circuit R and W<sub>2</sub> is completed by the second-stage heat room thermostat. Circuit R-W<sub>2</sub> energizes a heat sequencer (HR<sub>1</sub>). The completed circuit will energize supplemental electric heat. Units with a second heater sequencer (HR<sub>2</sub>) can be connected with first sequencer (HR<sub>1</sub>) to W<sub>2</sub> on thermostat or connected to a third heating stage W<sub>2</sub> on the thermostat sub-base. A light on the thermostat indicates when supplemental heat is being energized.

### 10.4 BLOWER TIME DELAY (HEATING OR COOLING)

- All models are equipped with a blower time delay (BTD) in lieu of a blower relay (BR) (see wiring diagram). The blower will run for 45 seconds after the blower time delay (BTD) is de-energized.

### 10.5 DEFROST (DEFROST HEAT CONTROL)

- For sequence of operation for defrost controls, see outdoor heat pump installation instructions.
- In serial communicating network:

When the outdoor unit control identifies a need to defrost a signal from the outdoor unit via the serial network to the control center and air handler control, indicating a defrost sequence is needed and backup heat (if available) should be initiated.
- Using conventional 24VAC thermostat wiring:

Supplemental heat during defrost can be provided by connecting the purple (PU) pigtail in the outdoor unit to the W on the thermostat. This will complete the circuit between R and W through a set of contacts in the defrost relay (DR) when the outdoor heat pump is in defrost. This circuit, if connected, will help prevent cold air from being discharged from the indoor unit during defrost.



- For most economical operation, if cold air is not of concern during defrost, the purple wire can be left disconnected. Supplemental heat will then come on only when called for by second stage room thermostat.

## 10.6 EMERGENCY HEAT (HEATING HEAT PUMP)

- In serial communicating network:  
If the heat source on the EcoNet™ Control Center is set to Emergency Heat Mode, the control center will command for emergency backup heat via the serial network to the air handler and will not request operation of the outdoor unit.
- Using conventional 24VAC thermostat wiring:  
If selector switch on thermostat is set to the emergency heat position, the heat pump will be locked out of the heating circuit, and all heating will be electric heat. Jumper should be placed between W<sub>2</sub> and E on the thermostat sub-base so that the electric heat control will transfer to the first stage heat on the thermostat. This will allow the indoor blower to cycle on and off with the electric heat when the fan switch is in the auto position.

## 10.7 ROOM THERMOSTAT (ANTICIPATOR SETTING)

See instructions with outdoor section, condensing unit or heat pump for recommended room thermostats.

- On units with one electric heat sequencer (HR<sub>1</sub>) (see wiring diagram on unit), heat anticipator setting should be .16.
- On units with two electric heat sequencers (HR<sub>1</sub> & HR<sub>2</sub>) (see wiring diagram on unit), heat anticipator setting should be .32 if both are connected to same stage on thermostat. Setting should be .16 if (HR<sub>1</sub> & HR<sub>2</sub>) are connected to separate stages.

**NOTE:** Some thermostats contain a fixed, non-adjustable heat anticipator. Adjustment is not permitted.

- The thermostat should be mounted 4 to 5 feet above the floor on an inside wall of the living room or a hallway that has good air circulation from the other rooms being controlled by the thermostat. It is essential that there be free air circulation at the location of the same average temperature as other rooms being controlled. Movement of air should not be obstructed by furniture, doors, draperies, etc. The thermostat should not be mounted where it will be affected by drafts, hot or cold water pipes or air ducts in walls, radiant heat from fireplace, lamps, the sun, T.V. or an outside wall. See instruction sheet packaged with thermostat for mounting and installation instructions.

# 11.0 CALCULATIONS

## 11.1 CALCULATING TEMPERATURE RISE

- The formula for calculating air temperature rise for electric resistance heat is:

$$\text{Temperature Rise } ^\circ\text{F} = \frac{3.16 \times \text{Watts}}{\text{CFM}}$$

Where: 3.16 = Constant, CFM = Airflow

## 11.2 CALCULATING BTUH HEATING CAPACITY

- The formula for calculating BTUH heating capacity for electric resistance heat is:

$$\text{BTUH Heating} = \text{Watts} \times 3.412$$

Where: 1 kW = 1000 Watts, 3.412 = Btuh/Watt

## 11.3 CALCULATING AIRFLOW CFM

- The formula for calculating airflow using temperature rise and heating BTUH for units with electric resistance heat is:

$$\text{CFM} = \frac{\text{Heating BTUH}}{1.08 \times \text{Temp. Rise}}$$

## 11.4 CALCULATING CORRECTION FACTOR

- For correction of electric heat output (kW or BTUH) or temperature rise at voltages other than rated voltage multiply by the following correction factor:

$$\text{Correction Factor} = \frac{\text{Applied Voltage}^2}{\text{Rated Voltage}^2}$$

## 12.0 PRE-START CHECKLIST

<b>PRE-START CHECKLIST</b>	
<input type="radio"/> YES <input type="radio"/> NO	Is unit properly located, level, secure and service-able?
<input type="radio"/> YES <input type="radio"/> NO	Has auxiliary pan been provided under the unit with separate drain? (Units installed above a finished ceiling).
<input type="radio"/> YES <input type="radio"/> NO	Is condensate line properly sized, run, trapped, pitched and tested?
<input type="radio"/> YES <input type="radio"/> NO	Is ductwork correctly sized, run, taped and insulated?
<input type="radio"/> YES <input type="radio"/> NO	Have all cabinet openings and wiring been sealed with caulking?
<input type="radio"/> YES <input type="radio"/> NO	Is the filter clean, in place and of adequate size?
<input type="radio"/> YES <input type="radio"/> NO	Is the wiring tight, correct and to the wiring diagram?
<input type="radio"/> YES <input type="radio"/> NO	Is the unit properly grounded and protected (fused)?
<input type="radio"/> YES <input type="radio"/> NO	Is the thermostat heat anticipator been set properly?
<input type="radio"/> YES <input type="radio"/> NO	Is the unit circuit breaker(s) rotated properly "on" up - "off" down?
<input type="radio"/> YES <input type="radio"/> NO	Are the unit circuit breaker(s) line lug cover(s) in place?
<input type="radio"/> YES <input type="radio"/> NO	Are all access panels in place and secure?
Refer to outdoor unit installation instructions for system start-up instructions and refrigerant charging instructions.	

## 13.0 MAINTENANCE

For continuing high performance, and to minimize possible equipment failure, it is essential that periodic maintenance be performed on this equipment. Consult your local dealer as to the proper frequency of maintenance and the availability of a maintenance contract

**IMPORTANT:** Before performing any service or maintenance procedures, see the “Safety Information” section at the front of this manual.

### WARNING

**Units with circuit breaker(s) meet requirements as a service disconnect switch, however, if access is required to the line side (covered) of the circuit breaker, this side of the breaker(s) will be energized with the breaker(s) de-energized. Contact with the line side can cause electrical shock resulting in personal injury or death.**

### 13.1 AIR FILTER (NOT FACTORY-INSTALLED)

Check the system filter every ninety days or as often as found to be necessary and if obstructed, clean or replace at once.

#### FILTER MAINTENANCE

Have your qualified installer, service agency or HVAC professional instruct you on how to access your filters for regular maintenance.

**IMPORTANT:** Do not operate the system without a filter in place.

- New filters are available from your local distributor.

### 13.2 INDOOR COIL - DRAIN PAN - DRAIN LINE

Inspect the indoor coil once each year for cleanliness and clean as necessary. It is recommended to use a non-acidic coil cleaner for all Rheem indoor coils. In some cases, it may be necessary to remove the filter and check the return side of the coil with a mirror and flashlight.

**IMPORTANT:** Do not use caustic household drain cleaners, such as bleach, in the condensate pan or near the indoor coil. Drain cleaners will quickly damage the indoor coil.

### 13.3 THE *ECONET™* AIR HANDLER CONTROL BOARD REPLACEMENT

Verification of the *EcoNet™* Air Handler control board failure is required before replacement. Access the diagnostic codes using a service tool or access the service menus using the control center (the system must be wired as a serial communicating system to access the service and installer menus using the thermostat). Reference the Air Handler

### WARNING

**Disconnect all power to unit before installing or servicing. More than one disconnect switch may be required to de-energize the equipment. Hazardous voltage can cause severe personal injury or death.**

Diagnostic Code Table in Section 5.8.

**NOTE:** The memory card is attached to the control box with a tether. The tether has an identification label that can be used to identify the memory card if replacement is needed.

**IMPORTANT:** Do not cut the tether attached to the memory card when replacing the *EcoNet™* Air Handler Control. Reinsert the memory card into the replacement *EcoNet™* Air Handler Control.

**FIGURE 32**  
**ECONET™ AIR HANDLER BOARD REPLACEMENT**

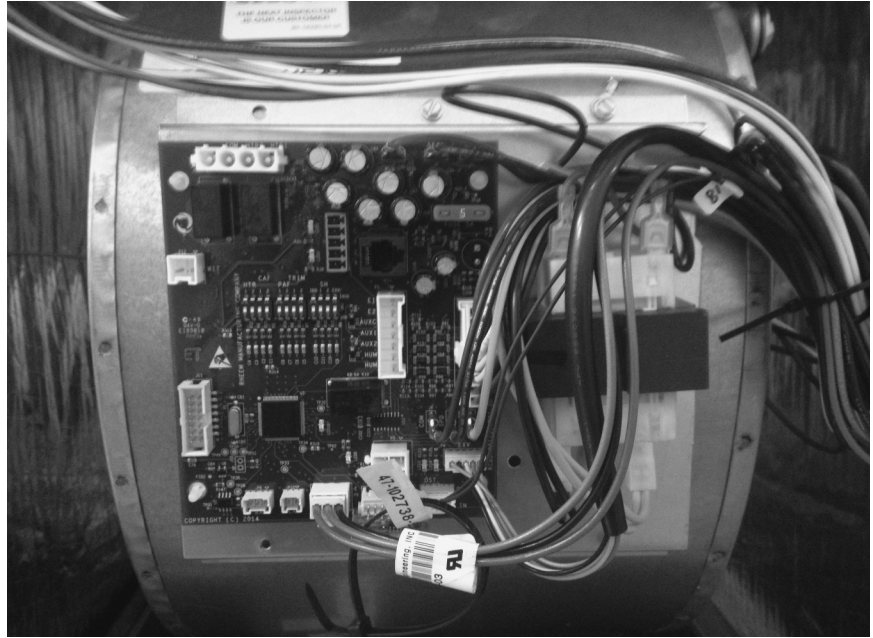

### 13.4 BLOWER MOTOR AND WHEEL

Inspect the blower motor and wheel for cleanliness. With the system air filter in place, it should be several years before it would become necessary to clean the blower motor and wheel.

- If it becomes necessary to remove the blower assembly from the unit, see instructions on removal and disassembly of motor, blower and heater parts.
- The blower motor and wheel may be cleaned by using a vacuum with a soft brush attachment. Remove grease with a mild solvent such as hot water and detergent. Be careful not to disturb the balance weights (clips) on the blower wheel blades. Do not drop or bend wheel as balance will be affected.

### 13.5 LUBRICATION

The blower motor sleeve bearings are pre-lubricated by the motor manufacturer and do not have oiling ports. Motor should be run for an indefinite period of time without additional lubrication.

### 13.6 BLOWER ASSEMBLY REMOVAL AND REPLACEMENT

Removing the blower assembly is not required for normal service and maintenance. Removal is necessary for replacement of components such as motor and/or blower wheel. After extended use, removal of the blower assembly may become necessary for a thorough cleaning of the blower motor and wheel.

#### **⚠ WARNING**

**If removal of the blower assembly is required, all disconnect switches supplying power to the airhandler must be de-energized and locked (if not in sight of unit) so the field power wires can be safely removed from the blower assembly. Failure to do so can cause electrical shock resulting in personal injury or death.**

- Mark field power supply wiring (for replacement) attached to terminal block or circuit breaker(s) on blower assembly. Remove wiring from terminal block or circuit breaker(s).
- Mark low voltage control wiring (for replacement) where attached to unit control terminals on left side of blower housing.
- Remove a screw holding blower assembly to front channel of cabinet and pull blower assembly from cabinet.
- To replace blower assembly, slide blower assembly into blower deck. Make sure blower assembly engages lances in deck properly. If assembly hangs up, check to make sure top and bottom are lined up in proper locations.
- Slide blower assembly to back of cabinet and make sure it is completely engaged.

- Replace two screws holding blower assembly to front channel of cabinet. Take care not to strip screws, just snug into place.
- Replace low voltage control wiring with wire nuts and make sure wiring is to wiring diagram and a good connection has been made.
- Replace field power wiring to terminal block or circuit breaker(s) on control area of blower assembly. Make sure wires are replaced as they were, check wiring diagram if necessary. Tighten supply power wiring securely to terminal lugs.
- Make sure wiring is within cabinet and will not interfere with access door. Make sure proper separation between low voltage control wiring and field power wiring has been maintained.
- Replace blower assembly control access panel before energizing equipment.

### 13.7 MOTOR REPLACEMENT

With the blower assembly removed, the indoor blower motor can be removed and replaced using the following procedure:

- Remove motor leads from the motor high and low voltage plugs. Note the lead locations for ease of re-assembly.
- Loosen the set screw holding the blower wheel onto the motor shaft. The shaft extends through the blower hub so that a wrench can be used on the extended shaft to break the shaft loose if necessary. Be careful not to damage the shaft. Use a wheel puller on the groove in the hub if necessary.
- Loosen the bolt holding the wire motor band around the motor shell and pull the motor from the motor mount. Note the motor position in the mount for re-assembly.
- To re-assemble, insert the motor shaft through the hub in the blower wheel and orient the motor to original position.
- For proper motor cooling, it is important that the motor be mounted the same as the original, as far into the blower as practical.
- The dimension from the face of the motor end plate (shaft end) to the edge of the motor mount belly band should be:

DIMENSION	TONNAGE	CABINET SIZE
1 1/2"	2	21
1 1/2"	3	21
2 7/8"	4	24
2 7/8"	5	24

**FIGURE 33**  
INTERNAL MOTOR PLUG AND SOCKET

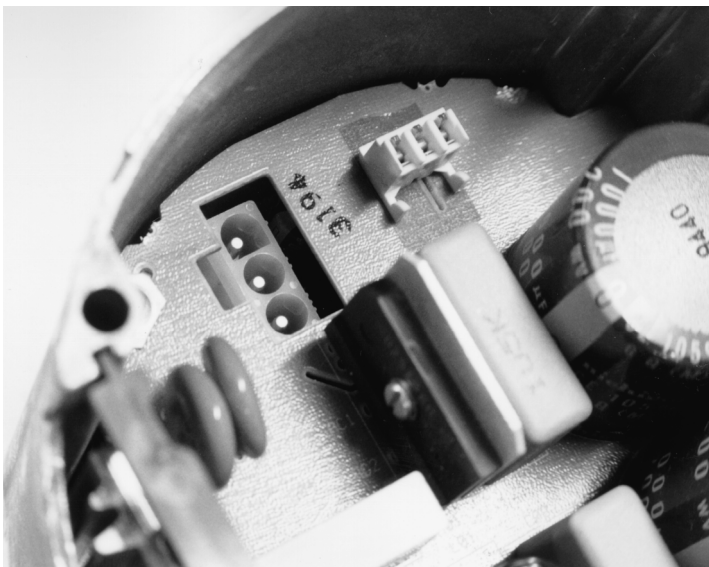

**FIGURE 34**  
ECM MOTOR COMPONENTS

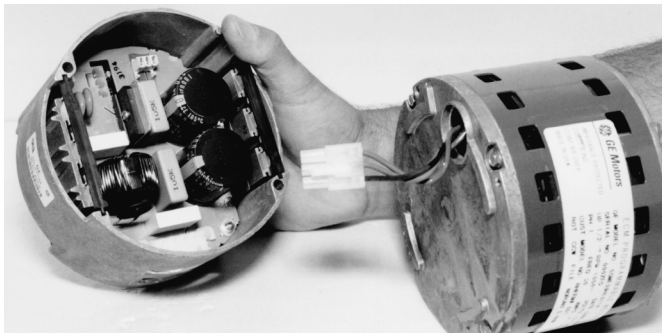

**FIGURE 35**  
MOTOR ALIGNMENT PIN

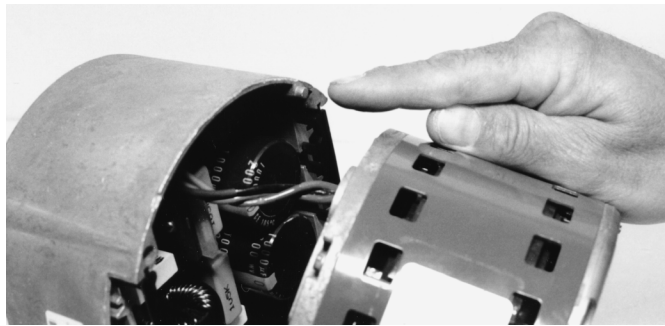

- With motor held to above position and motor lead plugs oriented to the original position (the wire connectors on the motor must point straight to the front of the unit. Securely tighten the bolt on the mount band to the motor shell.
- Turn the motor shaft so that the flat on the shaft is located under blower wheel setscrew, and the blower wheel is centered in the blower housing with the same distance on each side between the inlet venturi and the outside of the blower wheel.
- Re-assemble the motor wiring (high and low voltage plugs) into the motor.

**IMPORTANT: DO NOT FORCE POWER PLUG INTO THE MOTOR CONNECTOR BACKWARDS.** The A.C. power plug to the motor has locking tabs. It has been proven that by applying excessive force to the A.C. cable half of the connector it is possible to force the connector in backwards. It will not seat and “click” properly but will make connection. If A.C. power is applied with the connector reversed the motor will be immediately destroyed.

### 13.8 ECM CONTROL MODULE REPLACEMENT

The control module on serial communicating air handlers is field serviceable. The motor can be replaced or the motor control can be replaced.

### 13.9 BLOWER WHEEL REPLACEMENT

With the blower assembly removed and the motor assembly removed (see above instructions), remove the two screws holding the blower wrap (cutoff) to the blower sides.

**IMPORTANT:** It is not necessary to remove heating element(s), if provided, to remove the blower wheel.

- With wrap (cutoff) screws removed, cut off end of blower wrap will spring up. Lifting wrap blower wheel is removed through the discharge opening in the blower housing.
- To replace, make sure wheel is oriented properly with hub to the opposite side from the motor. Lift blower wrap and insert blower wheel through discharge opening in the blower housing.
- Hold blower wrap down into position and replace two screws holding blower wrap to blower sides.
- See motor replacement and blower assembly instructions for remaining assembly procedure.

---

## 14.0 REPLACEMENT PARTS

Any replacement part used to replace parts originally supplied on equipment must be the same as or an approved alternate to the original part supplied. The manufacturer will not be responsible for replacement parts not designed to physically fit or operate within the design parameters the original parts were selected for.

These parts include but are not limited to: Circuit breakers, heater controls, heater limit controls, heater elements, motor, motor capacitor, blower relay, control transformer, blower wheel, filter, indoor coil and sheet metal parts.

When ordering replacement parts, it is necessary to order by part number and include with the order the complete model number and serial number from the unit data plate. (See parts list for unit component part numbers).

# 15.0 ACCESSORIES - KITS - PARTS

- **Combustible Floor Base RXHB-17, RXHB-21, RXHB-24 (for standard units)** for downflow applications, see section of this manual covering combustible floor base.

Model Cabinet Size	Combustible Floor Base Model Number
17	RXHB-17
21	RXHB-21
24	RXHB-24

- **Jumper Bar Kit 3 Ckt. to 1 Ckt. RXBJ-A31** is used to convert single phase multiple three circuit units to a single supply circuit. Kit includes cover and screw for line side terminals.
- **Jumper Bar Kit 2 Ckt. to 1 Ckt. RXBJ-A21** is used to convert single phase multiple two circuit units to a single supply circuit. Kit includes cover and screw for line side terminals.

**NOTE:** No jumper bar kit is available to convert three phase multiple two circuit units to a single supply circuit.

- **External Filter Base RXHF- (See Figure 36)**

Model Cabinet Size	Filter Size	Part Number	A	B
17	16 x 20 [406 x 508]	RXHF-17 Accommodate	15.70	17.50
21	20 x 20 [508 x 508]	RXHF-21 1" or 2" filter	19.20	21.00
24	25 x 20 [635 x 508]	RXHF-24	22.70	25.50

- **Supply and Return Air Temperature Sensor Kit. RXHT-A02** is used to display supply and return air temperature measurements when using the air handler with a serial communicating thermostat.

**FIGURE 36**  
EXTERNAL FILTER BASE: RXHF-

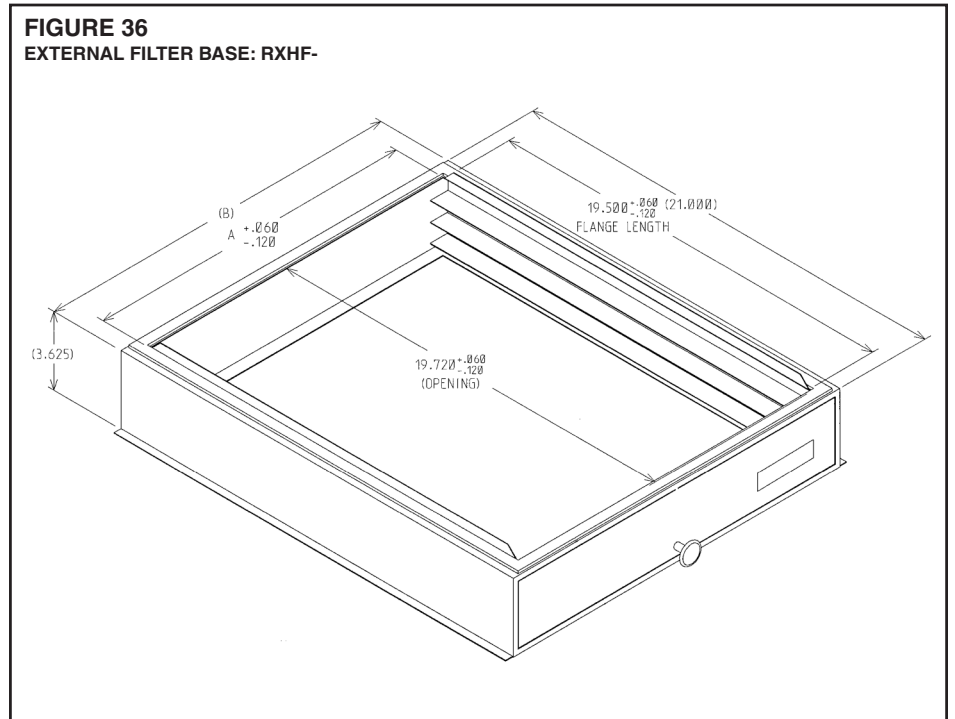

- **Horizontal Adapter Kit RXHH-**

This horizontal adapter kit is used to convert Upflow/Downflow only models to horizontal flow. See the following table to order proper horizontal adapter kit.

<b>Coil Model</b>	<b>Horizontal Adapter Kit Model Number (Single Qty.)</b>	<b>Horizontal Adapter Kit Model Number (10-pak Qty.)</b>
2417SE	RXHH-A02	RXHH-A02x10
3617SE/3621ME	RXHH-A03	RXHH-A03x10
4821ME	RXHH-A04	RXHH-A04x10
6024ME	RXHH-A05	RXHH-A05x10
4821SE/6021SE	RXHH-A06	RXHH-A06x10

- **Auxiliary Horizontal Overflow Pan RXBM-**

<b>Nominal Cooling Capacity Tons</b>	<b>Auxiliary Horizontal Overflow Pan Accessory Model Number</b>
1½ - 3	RXBM-AC48
3½ - 5	RXBM-AC61



FIGURE 37

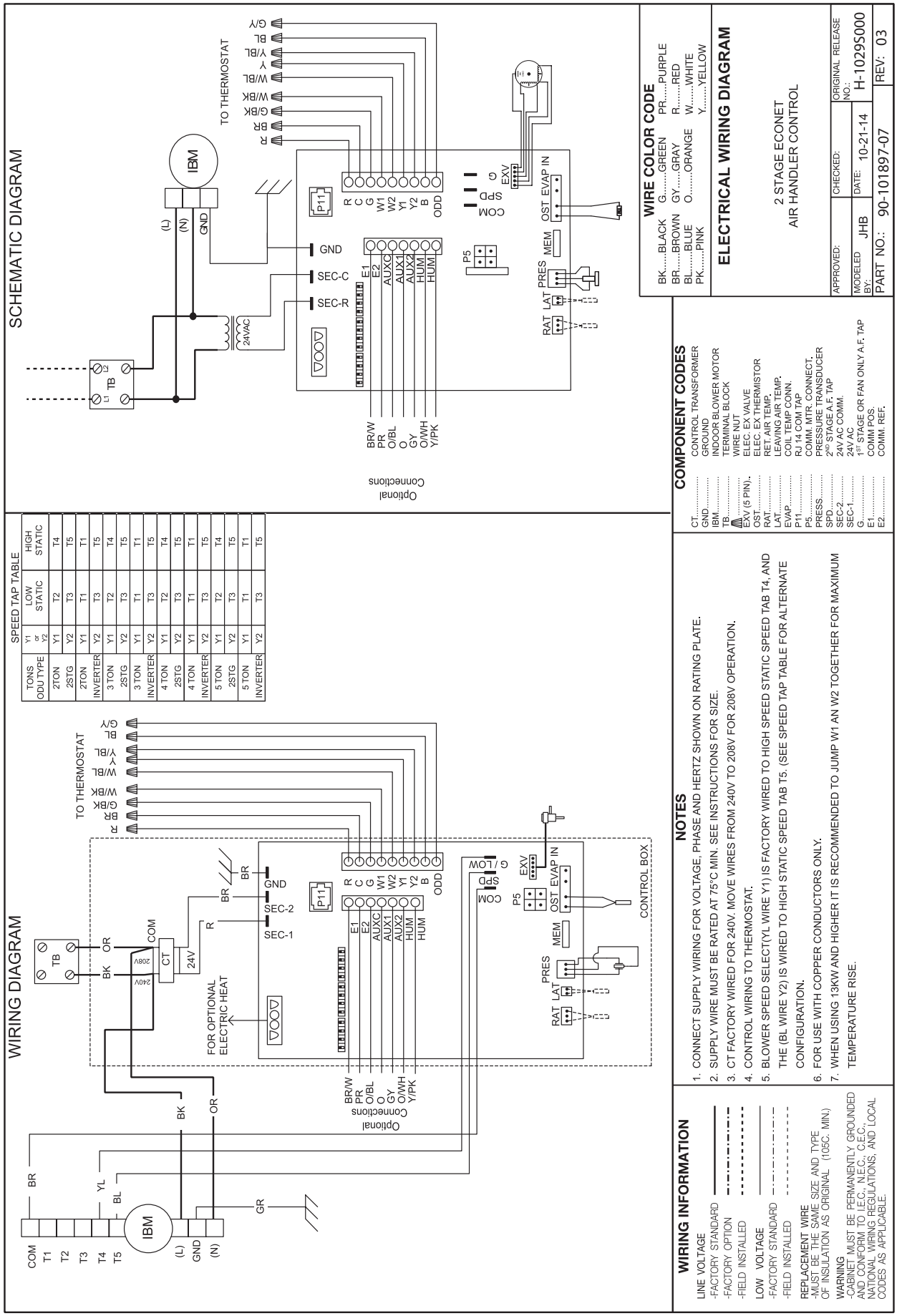

**SPEED TAP TABLE**

TONS	Y1	LOW	HIGH
ODU TYPE	Y2	STATIC	STATIC
2TON	Y1	T2	T4
2STG	Y2	T3	T5
3TON	Y1	T1	T1
3TON	Y2	T3	T5
3STG	Y2	T3	T5
4TON	Y1	T1	T1
4TON	Y2	T3	T5
4STG	Y2	T3	T5
5TON	Y1	T1	T1
5TON	Y2	T3	T5
5STG	Y2	T3	T5
INVERTER	Y2	T1	T1

FIGURE 38

SCHEMATIC DIAGRAM

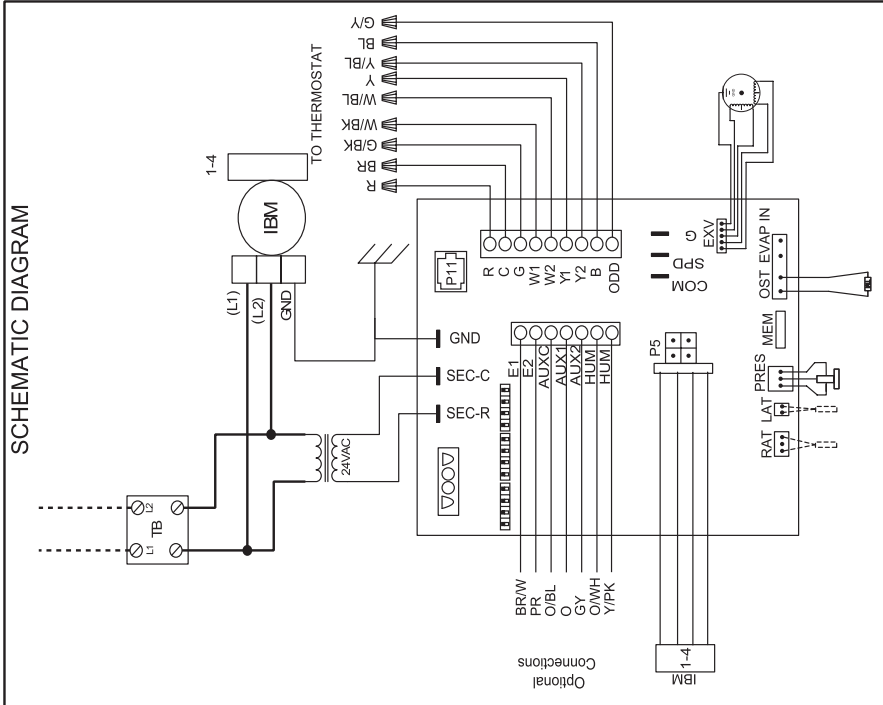

WIRING DIAGRAM

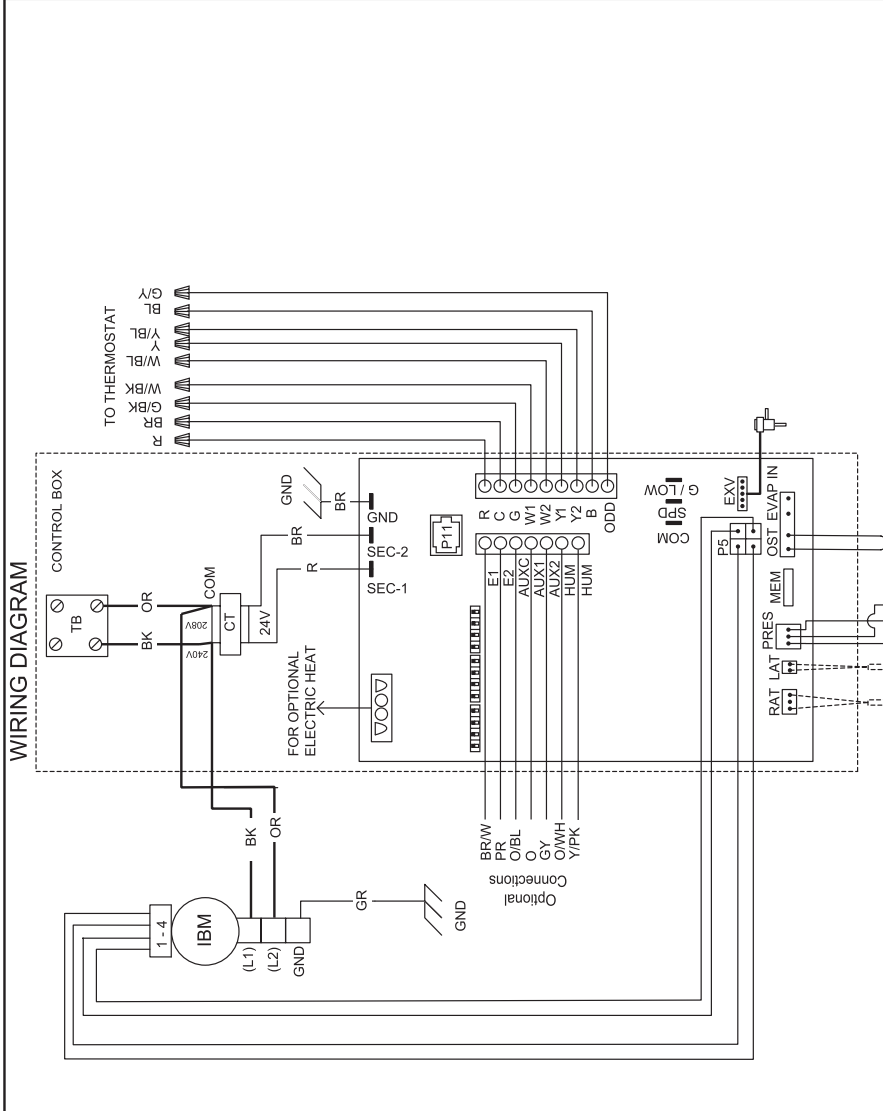

**WIRE COLOR CODE**

BK.....BLACK	G.....GREEN	PR.....PURPLE
BR.....BROWN	GY.....GRAY	R.....RED
BL.....BLUE	O.....ORANGE	W.....WHITE
PK.....PINK	Y.....YELLOW	

**ELECTRICAL WIRING DIAGRAM**

2 STAGE ECONET  
AIR HANDLER CONTROL  
ECM MOTOR  
CONSTANT CFM

APPROVED:	CHECKED:	ORIGINAL RELEASE NO.:
MOBELED	JHB	H-10295015
DATE:	10-21-14	
BY:		
PART NO.:	90-101897-08	REV: 02

**COMPONENT CODES**

CT.....	CONTROL TRANSFORMER
GND.....	GROUND
IBM.....	INDOOR BLOWER MOTOR
TB.....	TERMINAL BLOCK
▲.....	WIRE NUT
EV (5 PIN).....	ELEC EX VALVE
OST.....	VAPOR LINE THERMISTOR CONN.
LAT.....	LEAVING AIR TEMP.
PRES.....	COIL TEMP CONN.
MEM.....	RJ 14 COM TAP
P11.....	COMM. MTR. CONNECT.
P5.....	VAPOR LINE PRESS. TRANS.
SPD.....	2 <sup>ND</sup> STAGE A.F. TAP
SEC-2.....	24V AC COMM.
SEC-1.....	24V AC
G.....	1 <sup>ST</sup> STAGE OR FAN ONLY A.F. TAP
COM1 P5.....	COMM. REF.
E2.....	

- NOTES**
1. CONNECT SUPPLY WIRING FOR VOLTAGE, PHASE AND HERTZ SHOWN ON RATING PLATE.
  2. SUPPLY WIRE MUST BE RATED AT 75°C MIN. SEE INSTRUCTIONS FOR SIZE.
  3. CT FACTORY WIRED FOR 240V. MOVE WIRES FROM 240V TO 208V FOR 208V OPERATION.
  4. CONTROL WIRING TO THERMOSTAT.
  5. FOR USE WITH COPPER CONDUCTORS ONLY.
  6. WHEN USING 13KW AND HIGHER IT IS RECOMMENDED TO JUMP W1 AN W2 TOGETHER FOR MAXIMUM TEMPERATURE RISE.

**WIRING INFORMATION**

LINE VOLTAGE	-----
-FACTORY STANDARD	-----
-FACTORY OPTION	-----
-FIELD INSTALLED	-----
LOW VOLTAGE	-----
-FACTORY STANDARD	-----
-FIELD INSTALLED	-----

REPLACEMENT WIRE MUST BE THE SAME SIZE AND TYPE OF INSULATION AS ORIGINAL. (108C. MIN.)

WARNING  
-CABINET MUST BE PERMANENTLY GROUNDED AND CONFORM TO I.E.C., N.E.C., C.E.C. NATIONAL WIRING REGULATIONS, AND LOCAL CODES AS APPLICABLE.



