

# **Acoustic Listening Systems Lmic, Gmic and Rmic Operating Manual**



Palmer Environmental  
Ty Coch House  
Llantarnam Park Way  
Cwmbran  
NP44 3AW  
United Kingdom

Tel: +44 (0) 1633 489479  
Fax: +44 (0) 1633 877857  
Email: [info@palmer.co.uk](mailto:info@palmer.co.uk)  
Web: [www.palmer.co.uk](http://www.palmer.co.uk)

## Contents

<b>Introduction and Scope .....</b>	<b>2</b>
<b>Guidance to Effective Acoustic Leak Detection .....</b>	<b>3</b>
<b>Battery Warning.....</b>	<b>5</b>
<b>Lmic Acoustic Leak Sounding System .....</b>	<b>6</b>
<b>Preparing the Lmic for use.....</b>	<b>7</b>
<b>Using the Lmic .....</b>	<b>8</b>
<b>Lmic Technical specification .....</b>	<b>9</b>
<b>Gmic Acoustic Leak Sounding System.....</b>	<b>10</b>
<b>Gmic Controls .....</b>	<b>12</b>
<b>Preparing the Gmic for use .....</b>	<b>13</b>
<b>Using the Gmic.....</b>	<b>14</b>
<b>Gmic Technical Specification .....</b>	<b>16</b>
<b>Rmic Acoustic Leak Sounding System.....</b>	<b>18</b>
<b>Microphone foot warning .....</b>	<b>19</b>
<b>Using the Rmic .....</b>	<b>21</b>
<b>Rmic Technical Specification.....</b>	<b>22</b>
<b>Warranty.....</b>	<b>24</b>

## Introduction and Scope

This manual covers the principles in acoustic leak detection for the following products produced by Palmer Environmental.

Lmic (pronounced El Mike) Low cost leak sounding system

Gmic (pronounced Gee Mike) Ground microphone - leak sounding system

Rmic (pronounced Are Mike) Road microphone - leak sounding system.

The basics in the general operation are the same but each system has its own advantages.

**Lmic** is designed as a low cost lightweight system which is simple to use yet highly effective in the detection the sources of leak noise in industrial, commercial and even household situations and can be used as a tool as part of a plumbing tool kit.

**Gmic** is a more sophisticated piece of equipment containing filters and the option of aviation headphones. This combination provides the operator with a highly effective listening device with the ability to virtually eliminate unwanted or interfering ambient noise.

**Rmic** has the features of the Gmic but has the additional capability of being able to use an acoustically shielded ground microphone foot for use in all weathers especially high wind. The Rmic foot virtually eliminates the noise produced in bad weather conditions and is especially suited for use on hard road surfaces, tarmac, concrete etc.

The following section provides an introduction to the methods of acoustic leak detection.

## **Guidance to Effective Acoustic Leak Detection**

All acoustic leak detection methods are based on the premise that normal water passage through pipelines takes place noiselessly. When the water passage is disturbed a noise is created. Causes can include partial pipe blockages, sudden changes in pipe diameter, abrupt changes in pipe direction, pumps or meters installed in the pipeline, consumer usage or pipeline damage. Pipeline damage can include holes, cracks or splits, complete pipeline rupture, leaking joints or leaking valves.

Careful application of leak detection techniques will enable the operator to eliminate detected noises generated by poor pipeline design or consumer usage and to identify leakage due to pipe system damage.

The strength and clarity of noise generated by leaks will be affected by the water pressure, the size and shape of the orifice allowing leakage, the type of ground material around the pipeline, the type of ground cover over the pipe, the diameter, wall thickness and material of the pipeline and the quantity of water leaking.

A small orifice or hole and high water pressure generally produces a higher frequency noise. Often the noise level increases around valves, pipe elbows, T connections, pipe ends, etc. since the partial obstruction increases pressure and creates some further disturbance in the water path.

Leak noise is transmitted along the pipeline both through the water and the pipe wall as well as into the ground around the pipe. The noise travels much better through "hard" materials so that the noise travels much further along metallic pipes than asbestos cement pipes which themselves are better than plastic pipes. Ground material generally provides a poorer travel path than the pipeline itself. Soft sandy ground provides a worse travel path than well compacted ground with a hard paved surface covering.

The leak noise can change in strength and pitch as it travels along the pipe or through the ground. The deeper the pipe is buried and the softer the ground the more the noise will be dampened.

When a leak is produced in a metallic pipe the leak noise will transmit well through the pipe. It does not travel so well through a plastic pipe. This means that a leak noise can be heard further away on metal than on plastic. Also bear in mind that the further you go from a leak noise source the more difficult it is to pinpoint that leak noise accurately.

Background noise can interfere with leak detection. Traffic and machinery noises can travel for considerable distances through both air and ground material and often occur in the same frequency bands as leak noise. Sometimes it is necessary to use leak detection techniques at night when interfering noises are less.

It is very important to adopt a methodical approach when using any instrument for acoustic leak detection. It is necessary to practice the technique in order to distinguish between different sounds, recognising background or interfering noises,

so that they can be eliminated. It is also essential that other (non-leakage) noise sources such as consumer draw-off or partially closed valves are eliminated by logical site inspection practices prior to any excavation taking place.

### **Hand probe**

For normal soft ground surfaces the single pointed extension rod should be connected - do not overtighten the screw thread. For direct contact with underground fittings via access covers it may be necessary to use the second extension rod. To do this remove the single rod and connect the extension rod - replacing the pointed rod again. If the rods have been overtightened, spanner slots allow easy removal.

### **Surveying**

The leak location can be narrowed down by listening at accessible contact points such as meters, hydrants, valves and stop-taps, which provide points of good sound pick-up particularly if the pipe is metallic. Use the hand-probe/extension rod to listen at these points.

If there are no accessible contact points or if the pipe is of non-metallic material use the microphone foot for listening, placing the foot over the pipe route in the area of the suspected leak. Move along the pipe route listening at each accessible pipe-fitting or at regular positions on the ground until you have identified the area of maximum noise level.

*Note:* When you are listening on pipe-fittings the location of the point of maximum noise will probably not indicate the leak position, only the fitting closest to the leak. The noise level will also appear stronger where there is less thickness of ground or other material for it to pass through. The leak noise will follow the path of least resistance.

### **Pinpointing the leak position**

Pinpointing the leak position involves a process of comparing a number of leak noises. Select the most suitable sensor device; the microphone foot for hard ground surfaces or the hand probe for soft ground.

Operate the ground microphone and adjust the headphone volume control to a comfortable listening level. Once you have listened to the noise through the headphones, switch off the amplifier (hand button on the Lmic or the headphones button on Gmic/Rmic) and move the microphone foot or hand probe to the next test position.

Repeat the sequence to listen to each of the test locations moving along the pipe route in the direction where signal strength is increasing. If the leak noise level falls you have passed the leak and should go back and reduce the distance that you move between measurements. The loudest leak noise will then indicate the location of the leak bearing in mind the ground conditions already mentioned.

## **Battery Warning**

### **Gmic and Rmic**

The batteries supplied and fitted to the Gmic and Rmic units are rechargeable lithium ion. Do not short circuit or overcharge these batteries. Any misuse of these batteries may result in explosion or fire. They must not be used in any other application or used with any other equipment. Only batteries supplied by Palmer Environmental must be used.

### **Lmic**

The battery fitted to the Lmic is a rechargeable 9V PP3 Nickel Hydride battery. Any replacement battery must be rechargeable and have the same specification.

## Lmic Acoustic Leak Sounding System

The Lmic (pronounced “el mike”) is an easy-to-use, low cost, electronic listening stick and ground microphone combined. It is ideal for general leak sounding operations and can be fitted with either a tripod foot (for use as a ground microphone) or probe rods (for sounding at fittings or in soft ground).

The control unit is hand-held with a “trigger” operation and a volume/sensitivity rotary control. An LED indicates operation and battery status. It can be used to confirm the position of underground leaks audibly from ground level; sound pipe fittings; penetrate soft ground to listen for leaks or carry out traditional acoustic surveys.

### Equipment list

- 1 Lmic hand held control unit
- 2 Microphone unit with cable
- 3 Tripod unit
- 4 2 probe rods
- 5 AC adapter
- 6 Headphones
- 7 Carry bag
- 8 Instruction manual



The Lmic equipment is shown here. (Note the battery charger and manual are not shown).

### Lmic Controls

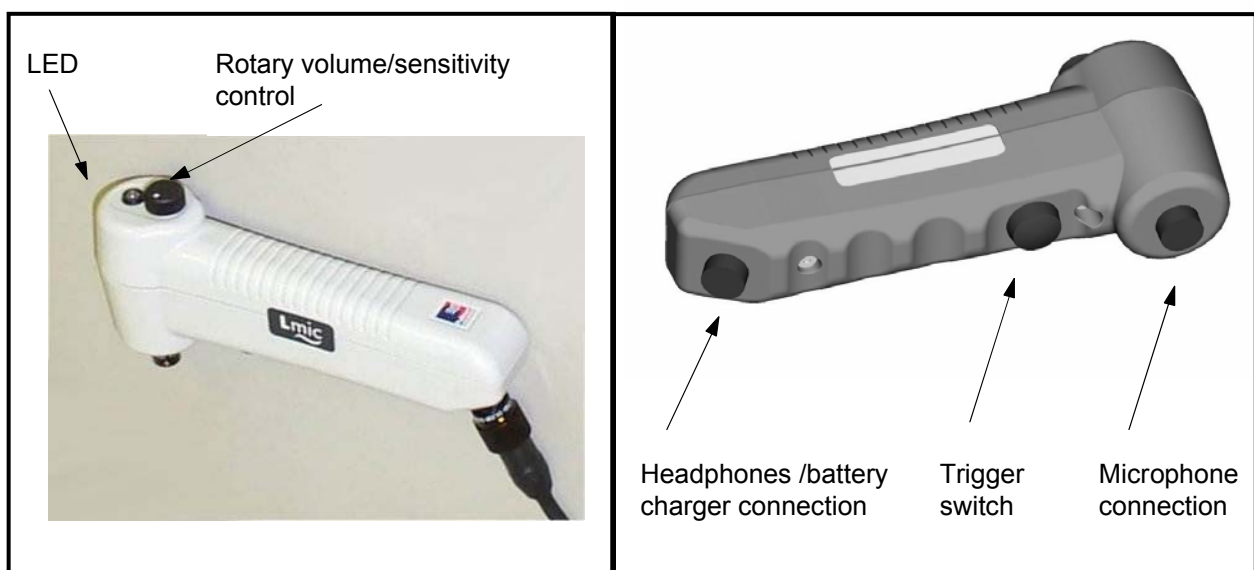

Top view of the Lmic showing the rotary control for volume and sensitivity.

Bottom view of the Lmic showing the trigger switch and the electrical connections for the headphones/battery charger and microphone.

## Preparing the Lmic for use

The rechargeable 9v PP3 battery for the Lmic is supplied installed within the hand control unit and will normally have only a nominal charge.

The battery will need charging either overnight (for up to 7 hours) to achieve full charge before being ready to use.

## Charging the Lmic batteries

Connect the charger lead to the rear connector of the Lmic and connect the charger power lead to the 240V AC supply. The Lmic can then be charged overnight. An optional accessory is the car cigarette lighter adapter that can also be used to charge the batteries.



The Lmic connected to the universal 110-240V AC charger

## Battery replacement

Although these batteries are rechargeable they may eventually need to be replaced. To do this, undo the two screws underneath the hand-held unit and separate the two halves of the Lmic unit. Gently pull out the battery holder and replace the batteries. When refitting the batteries and battery holder make sure no wires become trapped.



## Using the Lmic

The Lmic is simple to operate. Select either the probe rods or the tripod unit and screw into the microphone unit. (Use the tripod foot on hard ground and use the probe rods on soft ground or when accessing water pipe fittings).

Connect the headphones to the rear connector and connect the microphone cable to the forward connector. Put on the headphones and press the trigger button underneath the hand-held unit to listen for leaks.

The volume/sensitivity can be adjusted using the rotary control.

### LED indication

The green LED shows when the unit is operating and the red LED indicates low battery power.

### Care of the Lmic

The Lmic should be kept clean and dry and, where necessary, cleaned with a damp cloth; abrasive materials must not be used.



*The Lmic in use*

## **Lmic Technical specification**

### **Lmic hand held unit/sensor housing**

Piezoelectric high sensitivity sensor mounted in PC-ABS (polycarbonate) housing  
Single headphone/charger input socket with automatic sensing of device connected

### **Connectors**

Amphenol military specification connectors for microphone and headphone/charger connections

### **Charging**

Universal 110-240V AC charger with 12V DC output  
Car cigarette lighter adapter with 12V DC output (optional accessory)  
Charge time: Overnight charge.

### **Microphone housing**

High sensitivity piezo-electric sensor mounted in rubber housing with integral strain relief  
Low noise 0.75m cable (detachable)  
Weight: 400g

### **Foot attachment**

Cast metal tripod for ground contact

### **Hand probe attachment**

2 stainless steel extension rods (each 400mm long)  
Weight: 150g

### **Headphones**

Lightweight high quality headphones  
Impedance: 16 Ohms

### **LED**

Green = normal operation  
Red = low battery power

### **Optional accessories**

- High specification aviation quality headphones
- Car cigarette lighter adapter with 12V DC output
- Acoustically shielded ground microphone foot, for use in all weather conditions

# Gmic Acoustic Leak Sounding System

## Introduction

The Gmic (pronounced Gee Mike) is a highly effective ground microphone. It consists of a lightweight portable amplifier module, a set of mono headphones, and a combination listening probe and ground microphone.

It is an effective electronic instrument for locating and pinpointing leaks from buried water pipes.

Both visual and audible indications of signal strength (and consequent proximity) are provided to enable operators to quickly and accurately confirm leak positions.

The control module is battery powered and provides up to 50 hours operational use before a recharge is required.

Although the system is rugged and shower-proof (to IP65), it contains electronic circuitry and should be handled with care. The equipment should be kept dry and clean. Where necessary it should be cleaned with a damp cloth; abrasive materials must not be used.

**Note:** The headphones supplied with the Rmic cannot be interchanged. The impedance of the headphones is matched to the Rmic control unit during manufacture.

## Key features

- Lightweight, easily portable system
- Excellent acoustic performance
- Easy to use control unit
- Membrane keypad
- Backlit multifunction LCD
- 25 preset filter combinations
- Versatile – ground microphone and hand probe configurations
- Military specification connectors
- Robust construction for field use
- Rechargeable batteries (up to 50 hours use)
- Compact case containing full system

## System Description

### Control unit – robust for field conditions

The control unit is the operator interface. It is very easily portable, and can be carried with either hand- or shoulder-strap. Its injection-moulded housings are purpose-designed to provide long-term field durability and effective protection under realistic site conditions. It is environmentally rated to IP65.

The control unit has a membrane keypad, with push-key operation, and a backlit, multifunction LCD display. It interfaces to the headphones, charger and microphone via military-specification connectors.

### Versatile leak noise sensing

The acoustically shielded sensor mechanism provides isolation from airborne noise interference and can be fitted with either a tripod foot (for use as a ground microphone) or probe rods (for sounding at fittings or in soft ground).



### Standard equipment list:-

1. Control/amplifier module with adjustable carry strap.
2. Combined hand probe and ground microphone with integral cable.
3. Two 400mm stainless steel rods.
4. One short legged tripod.
5. Mono headphones.
6. Lithium ion battery pack Battery charger.
7. Carry case.

# Gmic Controls

The Gmic is simple to operate and has a limited number of controls.

## Controls and functions of the Gmic base unit

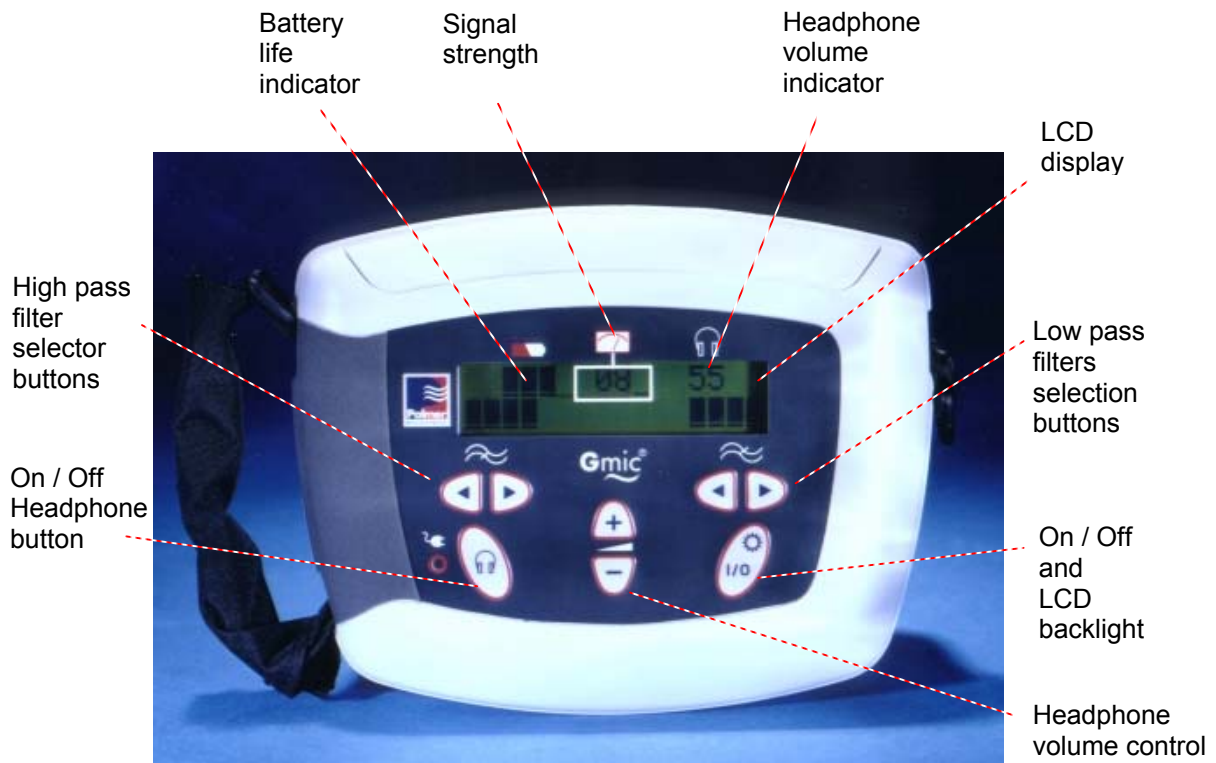

## **Preparing the Gmic for use**

The battery pack for the Gmic is supplied as a separate item in the carry case. The batteries within this pack are supplied quarter charged. To insert the battery pack into the Gmic unscrew the three screws underneath the unit, remove the cover and packing foam and connect the battery pack, place in the battery compartment, refit the packing foam, and then replace the cover with the three screws.

### **Battery charging**

To charge the batteries, connect the charge lead from the charger to the Headphones / Battery charge connector on the back of the Gmic. Plug the charger unit into the mains supply.

While the batteries are charging, the charging LED will be illuminated. This only goes out when the batteries are fully charged. The Gmic unit cannot be used while the batteries are charging. The time required to charge the batteries from flat is approximately 7 hours, which can be easily achieved overnight.

The On/Off switch can be pressed while the unit is on charge to see how much charge is in the batteries at any time. However, the Gmic **MUST** be switched back off again in order to resume charging.

When the unit is switched on the battery power available is indicated by three LCD blocks.

When all three blocks are illuminated, the batteries are fully charged.

When two blocks are illuminated, this indicates normal usage.

When only one block is illuminated, this indicates the battery is low on charge.

When the single block starts flashing, this indicates that the batteries are very low and should be recharged as soon as possible.

### **Battery replacement**

Although the batteries are rechargeable, they may eventually need to be replaced. Only batteries configured to the correct specification and type must be used. These are available from Palmer Environmental.

To replace the batteries, first switch the unit off. Unscrew the three screws underneath the unit, remove the packing foam, then unplug the battery pack connector releasing the batteries. Connect a new battery pack, place in the battery compartment, refit the packing foam, and then replace the cover with the three screws. The batteries will need charging

## Using the Gmic

Select the sensor attachment required, (the steel rod(s) or the tripod), and screw this into the bottom of the microphone housing. Plug the headphones into the Gmic.



### Gmic Switch On/Off.

Switch the unit on by momentarily pressing the On/Off switch. The unit will switch on and remain switched on until this same button is pressed again unless it is left unused. The Gmic will switch itself off after 30 minutes of inactivity.

To switch the unit off, the On/off switch must be pressed and held down for a few seconds.

### Headphones switch On/Off

The headphones can be used switched on in two different modes.

- a. **Latch mode.** Momentarily press the Headphones On/off button. The headphones will switch on and remain switched on until the Headphones On/Off button is pressed again.
- b. **Momentary mode.** Press and hold down the Headphones On/Off button. The headphones will remain switched on for as long as the button is pressed. As soon as the button is released, the headphones will switch off.

## Filter selection

To clarify the leak noise, background or unwanted noise frequencies can be filtered out using the High Pass and Low Pass filter buttons. To filter out low frequencies, use the High Pass buttons as shown below.

### High pass filter settings

High Pass filter

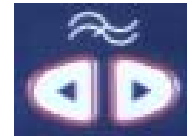

High  
pass  
filter

Press once to increment the filters at 30Hz intervals. This will only allow frequencies above each selection to pass through. All frequencies below this are blocked.

Press once for 30Hz

Press twice for 60Hz

Press three times for 90Hz

Press four times for 120Hz.

The high pass filters have these four settings only.

To reduce the filter setting, press the left hand button.

### Low pass filter settings

The low pass filter settings work in a similar way but with the ranges listed below. The highest frequency that can be passed through the unit is 3kHz.

To reduce the frequencies passed...

Press the left low-pass filter button once for 2kHz

Press twice for 1.5kHz

Press three times for 700Hz and

Press four times for 300Hz

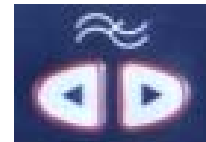

Low  
pass  
filter

The minimum band pass is 120 - 300Hz

There are a total of 25 combinations of selectable filter settings.

### Back light

To view the LCD display in bad light, illuminate the backlight by pressing the combined On/Off Backlight switch briefly. This then latches the backlight in an on-position. Note, the backlight automatically switches off after 1 minute to conserve battery power.

Press the same button again to re-illuminate the backlight.

To switch it off, press this same button momentarily.



# **Gmic Technical Specification**

## **Control Unit**

Low power analogue design with active digitally switched filters  
2 x 16 character LCD display with backlight control

## **LCD numerical display of:**

- Signal level display 0 – 99
- Headphone volume control
- Filter settings (25 possible)
- Battery level

## **Filter Options**

- High Pass - 20, 30, 60, 120Hz
- Low Pass – 300, 700, 1500, 2000Hz
- All Pass – 0-3000Hz
- Band Pass – Any combination of the above High / Low settings (25 total)

## **Power supply**

2 x Lithium ion 1.8Ah rechargeable batteries giving up to 50 hours operation without backlight (minimum 35 hours with backlight)

**Amphenol connectors** for microphone and headphone/charger connections

**Environmental rating** IP65

**Membrane keypad** with push-button control

**Dimensions** 206mm x 167mm x 86mm

**Weight** 1kg

**Charging** Universal 110-240V AC mains charger with 12V DC output

**Charge time** 8 hours

## **Microphone Housing**

High sensitivity piezo-electric sensor mounted in rubber housing with integral strain relief

Low noise 1.5m cable (detachable)

**Weight** 500g

## **Foot Attachment**

Cast metal tripod for ground contact

## **Hand Probe Attachment**

2 stainless steel extension rods (each 400mm in length)

Combined weight of rods 162g

## **Headphones**

Lightweight robust high fidelity headphones

## **Scope of supply**

- Control unit
- Microphone unit with lead
- Tripod foot
- 2 probe rods
- AC adapter
- Headphones
- Carry strap
- Transit case
- Instruction manual

# Rmic Acoustic Leak Sounding System

## Introduction

The Rmic (pronounced R Mike) is a highly effective ground microphone for all weather conditions. It consists of a lightweight portable amplifier module, as used in the Gmic system, a set of mono headphones, and a ground microphone housed within an acoustically shielded foot.

It is an effective electronic instrument to confirm the position of underground leaks audibly from ground level.

Audible indications of signal strength (and consequent proximity) are provided to enable operators to quickly and accurately confirm leak positions.

The control module is battery powered and provides up to 50 hours operational use before a recharge is required.

Although the system is rugged and shower-proof (to IP65), it contains electronic circuitry and should be handled with care. The equipment should be kept dry and clean. Where necessary it should be cleaned with a damp cloth; abrasive materials must not be used.

Optional extras include standard aviation quality headphones and a hand held probe for sounding fittings.

**Note:** The headphones supplied with the Rmic cannot be interchanged. The impedance of the headphones is matched to the Rmic control unit during manufacture.

## Key features

- Lightweight, easily portable system
- Excellent acoustic performance
- Easy to use control unit
- Membrane keypad
- Backlit multifunction LCD
- 25 preset filter combinations
- Versatile – ground microphone and optional hand probe configurations
- Military specification connectors
- Robust construction for field use
- Rechargeable batteries (up to 50 hours use)
- Compact case containing full system
- Optional aviation quality headphones

## Microphone foot warning

The Microphone foot has a sensor attached that can be seen from the bottom of the unit. **Users must not attempt to unscrew this sensor as this will break internal components of the microphone resulting in irreparable internal damage.** Sensor replacement is then the only option.

Any necessary repair or dismantling of the foot must be carried out by Palmer Environmental or by an authorised distributor.

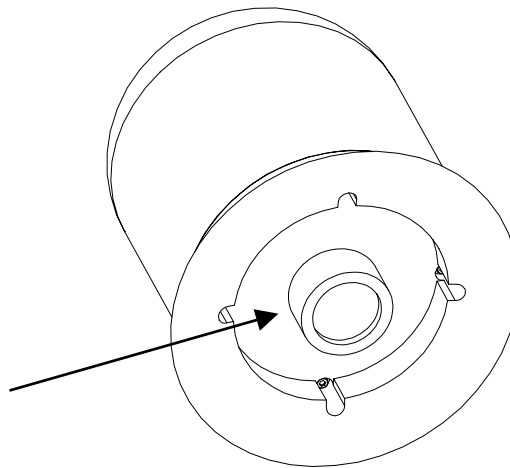

**Sensor:**

**Do NOT attempt to unscrew.**

## Rmic System Description

### Control unit – robust for field conditions

The control unit is the operator interface. It is very easily portable, and can be carried with either hand- or shoulder-strap. Its injection-moulded housings are purpose-designed to provide long-term field durability and effective protection under realistic site conditions. It is environmentally rated to IP65.

The control unit has a membrane keypad, with push-key operation, and a backlit, multifunction LCD display. It interfaces to the headphones, charger and microphone via military-specification connectors.

### Versatile leak noise sensing

The high sensitivity sensor is enclosed within a windproof nitrile rubber housing to ensure maximum practical acoustic isolation.



### Standard equipment list:-

1. Control/amplifier module with adjustable carry strap.
2. Ground microphone plus cable and 2 piece handle.
3. Standard mono headphones.
4. Lithium ion battery pack battery charger.
5. Carry case.

### Optional Upgrades/Additions

- Hand held probe with 2 x 400 mm rods
- Additional 400 mm extension rods
- Headphone Upgrades
  - Studio Quality
  - Aviation Quality

## Using the Rmic

To prepare the Rmic for use follow the instructions for the Gmic

The Rmic uses the same control unit as the Gmic and uses the same headphones (and options). The advantage of the Rmic over Gmic is evident when there is a need for the microphone sensor to be acoustically shielded from the surrounding environment – either ambient noise or bad weather such as rain or wind. The Rmic is especially suited for use on roads (hence Rmic – Road Microphone) where it can be used to detect the position of leak noise under the surface.

For information on the control unit see the Gmic control unit section of this manual and for general acoustic leak detection information see the guidance section towards the beginning of this manual.

# Rmic Technical Specification

## Control Unit

Low power analogue design with active digitally switched filters  
2 x 16 character LCD display with backlight control

## LCD numerical display of:

- Signal level display 0 – 99
- Headphone volume control
- Filter settings (25 possible)
- Battery level

## Filter Options

- High Pass - 20, 30, 60, 120Hz
- Low Pass – 300, 700, 1500, 2000Hz
- All Pass – 0-3000Hz
- Band Pass – Any combination of the above High / Low settings (25 total)

## Power supply

2 x Lithium ion 1.8Ah rechargeable batteries giving up to 50 hours operation without backlight (minimum 35 hours with backlight)

**Amphenol connectors** for microphone and headphone/charger connections

**Environmental rating** IP65

**Membrane keypad** with push-button control

**Dimensions** 206mm x 167mm x 86mm

**Weight** 1kg

**Charging** Universal 110-240V AC mains charger with 12V DC output

**Charge time** 8 hours

## **Microphone Housing**

High sensitivity piezo-electric sensor mounted in windproof, nitrile rubber housing.  
Low noise 1.5m cable (detachable)  
Weight 2.9kg

## **Hand Probe Attachment (Optional Upgrade)**

2 stainless steel extension rods (each 400mm in length)  
Combined weight of rods 162g

## **Headphones**

Standard Lightweight robust high fidelity headphones  
Optional upgrade to studio quality or aviation quality headphones

## **Scope of supply**

- Control unit
- Microphone foot unit with lead
- AC adapter
- Standard Headphones
- Carry strap
- Transit case
- Instruction manual

## **Optional Upgrades**

- Hand held probe with 2 x 400mm rods  
(weight 400g)
- Additional 400 mm extension rods
- Headphone Upgrades - Studio Quality  
- Aviation Quality
- Hand held switch control



## **Warranty**

All equipment is warranted by Palmer Environmental Ltd to be free from defects in materials and workmanship for a period of one year (unless otherwise stated) from the date of shipment to the original customer. This warranty is only valid if the equipment has been installed and used in the correct manner as described in this manual.

Repair or replacement (at Palmer Environmental's option) will be made without charge provided the above conditions have been met.

If any problems occur, notify Palmer Environmental Ltd or its authorised representative giving full details of the problem, and the model and serial number of the equipment. You will receive technical advice and/or shipping instructions depending upon the nature of the problem.

**Palmer Environmental Ltd**  
**Ty Coch House**  
**Llantarnam Park Way**  
**Cwmbran**  
**NP44 3AW**  
**United Kingdom**

**Tel: +44 (0) 1633 489479**  
**Fax: +44 (0) 1633 877857**  
**email: [info@palmer.co.uk](mailto:info@palmer.co.uk)**  
**<http://www.palmer.co.uk>**