

# IMPORTANT INSTRUCTIONS - OPERATING MANUAL

RS Series



Range Hood



**READ AND SAVE THESE INSTRUCTIONS**  
READ CAREFULLY BEFORE ATTEMPTING TO ASSEMBLE, INSTALL, OPERATE OR MAINTAIN THE PRODUCT DESCRIBED. PROTECT YOURSELF AND OTHERS BY OBSERVING ALL SAFETY INFORMATION. FAILURE TO COMPLY WITH INSTRUCTIONS COULD RESULT IN PERSONAL INJURY AND/OR PROPERTY DAMAGE!



RETAIN INSTRUCTIONS FOR FUTURE REFERENCE.

## GENERAL SAFETY INFORMATION



**WARNING:** TO REDUCE THE RISK OF FIRE, ELECTRIC SHOCK AND INJURY TO PERSON, OBSERVE THE FOLLOWING:

- Use this unit only in the manner intended by the manufacturer. If you have questions, contact the manufacturer.



**WARNING:** TO REDUCE THE RISK OF FIRE, ELECTRIC SHOCK AND INJURY TO PERSON, OBSERVE THE FOLLOWING:

- When cutting or drilling into wall or ceiling, do not damage electrical wiring and other hidden utilities.
- Read all instructions before installing or using shell.



**WARNING:** TO REDUCE THE RISK OF A RANGE TOP GREASE FIRE:

- Never leave surface units unattended at high settings. Boilovers cause smoking and greasy spillovers that may ignite. Heat oils slowly on low or medium settings.
- Use proper pan size. Always use cookware appropriate for the size of the surface element.



**WARNING:** TO REDUCE THE RISK OF INJURY TO PERSONS IN THE EVENT OF A RANGE TOP GREASE FIRE, OBSERVE THE FOLLOWING:

- SMOTHER FLAMES with a close-fitting lid, cookie sheet, or metal tray, then turn off burner. BE CAREFUL TO PREVENT BURNS. If the flames do not go out immediately, EVACUATE AND CALL THE FIRE DEPARTMENT.
- NEVER PICK UP A FLAMING PAN - You may be burned.
- DO NOT USE WATER, including wet dishcloths or towels - a violent steam explosion will result.
- Use an extinguisher ONLY if:
  - You know you have a Class ABC extinguisher, and you already know how to operate it.
  - The fire is small and contained in the area where it started.
  - The fire department is being called.
  - You can fight the fire with your back to an exit.

## INSTALLATION INSTRUCTIONS

### SECTION 1

#### Preparing the Shell

- Unpack shell from the carton and confirm that all pieces are present. In addition to the shell you should have:
  - 2 - #8 x 3/8 AB Screws
  - 4 - #8 Mounting Screws
  - 1 - Instruction/Safety Sheet

**NOTE:** Some shells may be shipped with a protective plastic adhered to the shell. It is recommended to leave this in place during installation to protect the shell from scratching. Remove when the installation is complete.

### SECTION 2

#### Prepare the location for Shell Support

- If the shell will be installed under cabinets that have a recessed bottom, it will be necessary to install wood mounting strips (not included) so the shell will mount properly (Figure 2).

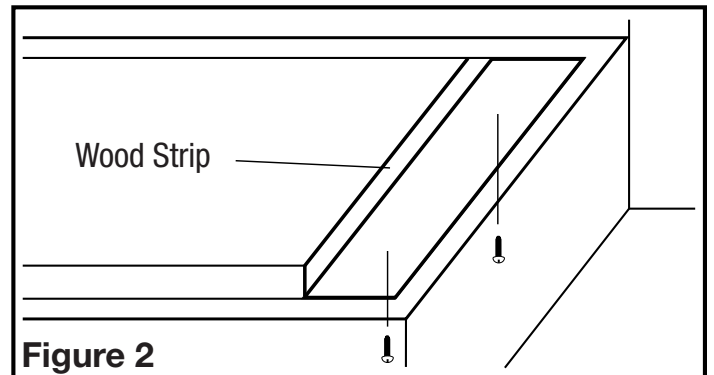

- The thickness of the strips should be the same as the recess of the cabinet and they should be approximately 2" wide.
- Install the strips using appropriate length wood screws (not included). Make sure the strips line up to the keyhole slots of the shell.

### SECTION 3

#### Installing the Shell

- Hold the shell up to the installation location and mark the locations of the mounting holes or mark the locations by measurement.

**SAVE THESE INSTRUCTIONS**

4. Install the 4 mounting screw at the previously marked locations. Leave approximately 1/8" clearance. Slide the shell in place through the keyhole slots and align the front of the shell so that it is flush with the front of the cabinets. Tighten all screws securely (Figure 4).

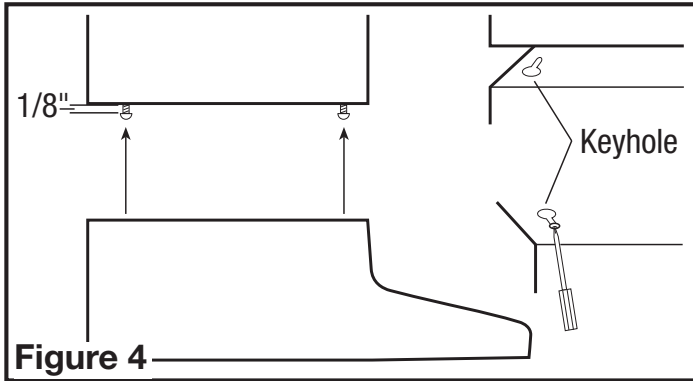

## SECTION 4

### Maintenance

#### Cleaning



**CAUTION:** DO NOT USE GASOLINE, BENZINE, THINNER, HARSH CLEANSERS, ETC., AS THEY MAY DAMAGE THE RANGE HOOD.

1. Clean your shell with a mild detergent, such as dishwashing liquid, and dry with a soft cloth. NEVER USE ANY ABRASIVE PADS OR SCOURING POWDERS.

## LIMITED WARRANTY

**WHAT THIS WARRANTY COVERS:** This product is warranted against defects in workmanship and/or materials.

**HOW LONG THIS WARRANTY LASTS:** This warranty extends only to the original purchaser of the product and lasts for one (1) year from the date of original purchase or until the original purchaser of the product sells or transfers the product, whichever first occurs.

**WHAT AIR KING WILL DO:** During the warranty period, Air King will, at its sole option, repair or replace any part or parts that prove to be defective or replace the whole product with the same or comparable model.

**WHAT THIS WARRANTY DOES NOT COVER:** This warranty does not apply if the product was damaged or failed because of accident, improper handling or operation, shipping damage, abuse, misuse, unauthorized repairs made or attempted. This warranty does not cover shipping costs for the return of products to Air King for repair or replacement. Air King will pay return shipping charges from Air King following warranty repairs or replacement **ANY AND ALL WARRANTIES, EXPRESSED OR IMPLIED (INCLUDING, WITHOUT LIMITATION, ANY IMPLIED WARRANTY OF MERCHANTABILITY), LAST ONE YEAR FROM THE DATE OF ORIGINAL PURCHASE OR UNTIL THE ORIGINAL PURCHASER OF THE PRODUCT SELLS OR TRANSFERS THE PRODUCT, WHICHEVER FIRST OCCURS AND IN NO EVENT SHALL AIR KING'S LIABILITY UNDER ANY EXPRESS OR IMPLIED WARRANTY INCLUDE (I) INCIDENTAL OR CONSEQUENTIAL DAMAGES FROM ANY CAUSE WHATSOEVER, OR (II) REPLACEMENT OR REPAIR OF ANY HOUSE FUSES, CIRCUIT BREAKERS OR RECEPTACLES. NOTWITHSTANDING ANYTHING TO THE CONTRARY, IN NO EVENT SHALL AIR KING'S LIABILITY UNDER ANY EXPRESS OR IMPLIED WARRANTY EXCEED THE PURCHASE PRICE OF THE PRODUCT AND ANY SUCH LIABILITY SHALL TERMINATE UPON THE EXPIRATION OF THE WARRANTY PERIOD.**

Some states and provinces do not allow limitations on how long an implied warranty lasts, or the exclusion or limitation of incidental or consequential damages, so these exclusions or limitations may not apply to you. This warranty gives you specific legal rights. You may also have other rights which vary from state to state and province to province. Proof of purchase is required before a warranty claim will be accepted.

## CUSTOMER SERVICE:

Toll-Free (800) 465-7300

Our Customer Service team is available to assist you with product questions, service center locations, and replacement parts. They can be reached Monday through Friday, 8am-4pm Eastern. Please have your model number available, as well as the type and style (located on the label inside of your product).

Please do not return product to place of purchase.

[www.airkinglimited.com](http://www.airkinglimited.com)

**PARTS FOR DISCONTINUED, OBSOLETE AND CERTAIN OTHER PRODUCTS MAY NOT BE AVAILABLE. DUE TO SAFETY REASONS, MANY ELECTRONIC COMPONENTS AND MOST HEATER COMPONENTS ARE NOT AVAILABLE TO CONSUMERS FOR INSTALLATION OR REPLACEMENT.**