

6EC SERIES - 1/3 HP

APPLICATIONS

Basement sumps, dewatering, water transfer, light effluent

FEATURES

- Heavy-duty cast iron construction
- Permanent split capacitor (PSC) motor with thermal overload protection
- Designed for continuous duty
- Energy-saving low amp draw
- 1-1/2" FNPT discharge (38 mm)
- Handles up to 1/2" (12.7 mm) solids
- Multiple switch options for automatic operation
- 140 °F (60 °C) liquid temperature rating
- cCSAus listed



SERIES SPECIFICATIONS

| Volts | Hz | Amps | | Watts | Performance (GPM @ Height in Feet) | | | | Shut-Off (ft) | PSI |
|-------|----|------|-------|-------|------------------------------------|-----|-----|-----|---------------|------|
| | | FLA | Start | | 5' | 10' | 15' | 20' | | |
| 115 | 60 | 5 | 14.5 | 600 | 53 | 50 | 42 | 34 | 28 | 12.1 |

| Item | Model | HP | Volts | Base Material | Switch Type/Operations | On Level | Off Level | Cord | Weight |
|--------|-------------|-----|-------|---------------|------------------------------|------------------------------------|-----------------------------------|----------------|-----------------------|
| 506803 | 6EC-CIA-RF | 1/3 | 115 | Polypropylene | Piggyback Mechanical Float | 13" - 15" (33.2 cm - 38.1 cm) | 6" - 8" (15.2 cm - 20.3 cm) | 10' (3 m) | 27.5 lbs (12.5 Kg) |
| 506858 | 6EC-CIA-RF | 1/3 | 115 | Cast Iron | Piggyback Mechanical Float | 13" - 15" (33.2 cm - 38.1 cm) | 6" - 8" (15.2 cm - 20.3 cm) | 20' (6.1 m) | 35.5 lbs (16.1 Kg) |
| 506808 | 6EC-CIA-RF | 1/3 | 115 | Polypropylene | Piggyback Mechanical Float | 13" - 15" (33.2 cm - 38.1 cm) | 6" - 8" (15.2 cm - 20.3 cm) | 30' (9.1 m) | 27.5 lbs (12.5 Kg) |
| 506807 | 6EC-CIA-SFS | 1/3 | 115 | Polypropylene | Integral Snap-Action Float | 8" - 11" (20.3 cm - 27.9 cm) | 2" - 5" (5.1 cm - 12.7 cm) | 10' (3 m) | 28 lbs (12.7 Kg) |
| 506804 | 6EC-CIA-SFS | 1/3 | 115 | Polypropylene | Integral Snap-Action Float | 8" - 11" (20.3 cm - 27.9 cm) | 2" - 5" (5.1 cm - 12.7 cm) | 20' (6.1 m) | 29 lbs (13.5 Kg) |
| 506801 | 6EC-CIM | 1/3 | 115 | Polypropylene | Manual | - | - | 10' (3 m) | 26.5 lbs (12 Kg) |
| 506802 | 6EC-CIM | 1/3 | 115 | Polypropylene | Manual | - | - | 20' (6.1 m) | 27.5 lbs (12.5 Kg) |
| 506809 | 6EC-CIA-DS | 1/3 | 115 | Polypropylene | Piggyback Vertical Diaphragm | 8" - 10.9" (20.3 cm - 27.7 cm) | 2.8" - 5.9" (7.1 cm - 15 cm) | 10' (3m) | 27 lbs (12.2 kg) |
| 506810 | 6EC-CIA-DS | 1/3 | 115 | Polypropylene | Piggyback Vertical Diaphragm | 8" - 10.9" (20.3 cm - 27.7 cm) | 2.8" - 5.9" (7.1 cm - 15 cm) | 18' (5.5m) | 28 lbs (12.7 kg) |
| 506811 | 6EC-CBA-SFS | 1/3 | 115 | Polypropylene | Integral Snap-Action Float | 7.6" - 9.6" (19.3 cm - 24.4 cm) | 3.0" - 5.0" (7.7 cm - 12.7 cm) | 20' (6.1m) | 27.8 lbs (12.6 kg) |
| 506812 | 6EC-CBM | 1/3 | 115 | Polypropylene | Manual | - | - | 20' (3m) | 26.9 lbs (12.2 kg) |

6EC SERIES - 1/3 HP

ENGINEERING DATA

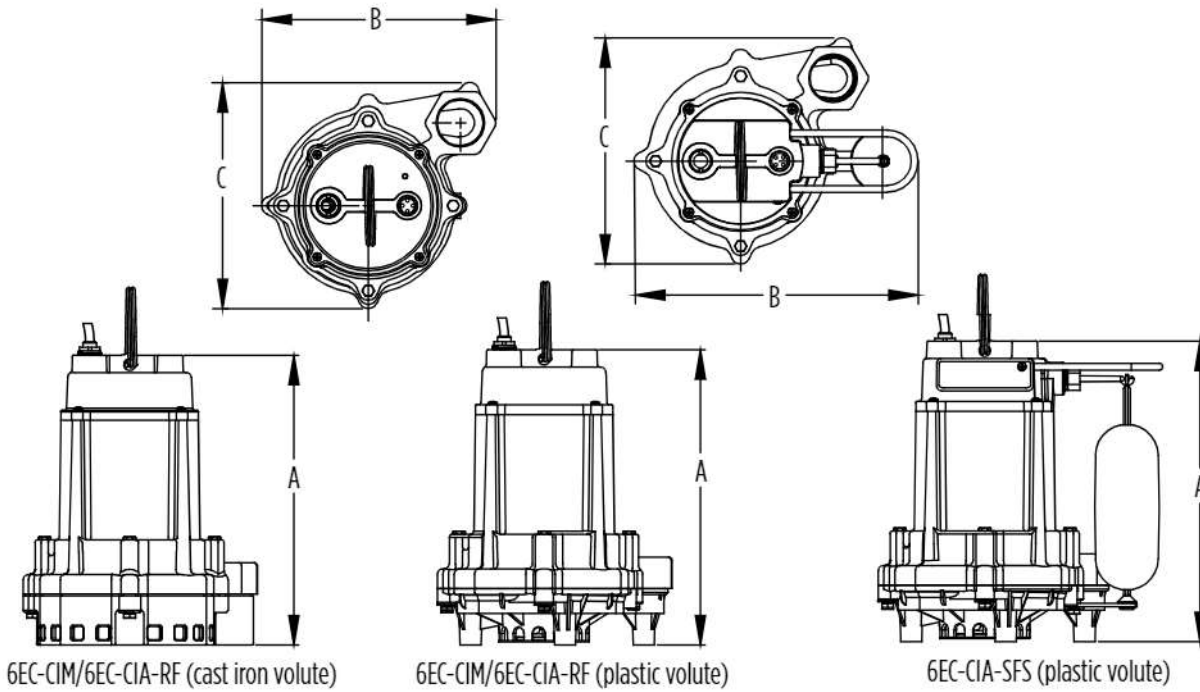

6EC-CIM/6EC-CIA-RF (cast iron volute)

6EC-CIM/6EC-CIA-RF (plastic volute)

6EC-CIA-SFS (plastic volute)

