

77C-100-UL SERIES

Bronze Full Port Ball Valve For Trim & Drain "Contractor" Series

Female NPT Thread, 600 CWP (psig), 150 SWP (psig).
 Vacuum Service to 29 inches Hg.
 MSS SP-110 compliant.
 UL Listed VQGU, "Valves, Trim and Drain", per UL 258 at 300 psig max.



FEATURES

- Machined Solid Chrome-Plated Ball
- Multi-Fill PTFE Seats & Seals
- Blow-out-proof stem design
- Adjustable packing gland
- Full Port Design Through 2"

VARIATIONS AVAILABLE:

77C-140 Series (316 SS Ball & Stem)

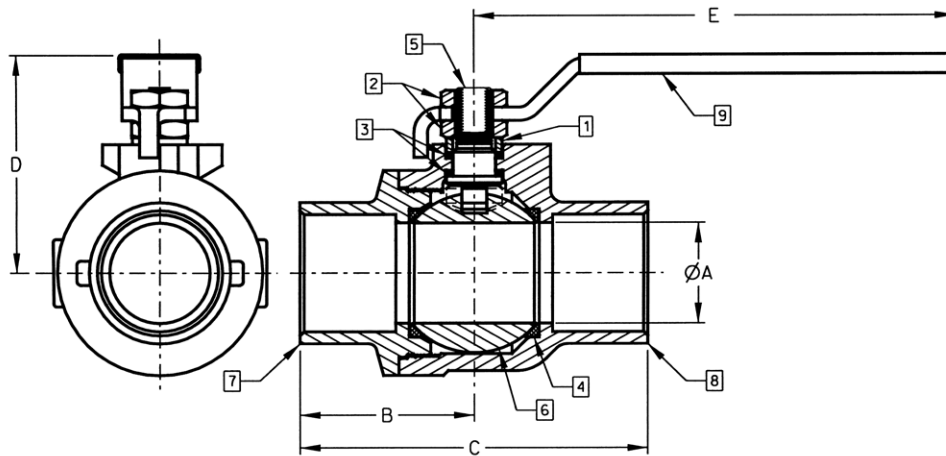

STANDARD MATERIAL LIST

PART	MATERIAL
1 Gland	B16 Brass
2 Nut	Zinc Plated Steel
3 Packing	MPTFE
4 Seat	MPTFE
5 Stem	B16 Brass
6 Ball	B16 (chromium plated)
7 Retainer	B584 Bronze*
8 Body	B584 Bronze
9 Handle	Zinc Plated Steel/Vinyl

*1/4" - 1/2" B16 Brass

PRODUCT NUMBER	SIZE	A	B	C	D	E	Cv	WT.**
77C-101-UL	1/4"	0.37	0.95	1.97	1.76	3.74	5	0.6
77C-102-UL	3/8"	0.37	1.07	2.09	1.76	3.74	7	0.5
77C-103-UL	1/2"	0.50	1.15	2.25	1.79	3.74	16	0.6
77C-104-UL	3/4"	0.75	1.32	2.65	2.00	4.88	36	1.0
77C-105-UL	1"	1.00	1.53	3.07	2.19	4.88	68	1.8
77C-106-UL	1.25"	1.25	2.04	4.08	3.13	7.06	125	4.4
77C-107-UL	1.5"	1.50	2.12	4.23	3.29	7.06	177	4.6
77C-108-UL	2"	2.00	2.43	4.85	3.83	7.06	389	8.1

**Weights are based on standard configuration 77C-10X-01.

