

**PRODUCT SPECIFICATIONS**

Remote type, electric refrigerated water chiller unit. Chilling Capacity of 2.0 GPH (gallons per hour) of 50° F drinking water, based on 80° F inlet water and 90° F ambient, per ASHRAE 18 testing. Installs directly under fountain or other application, or may be located in a service area to serve a remote outlet (within 15 feet recommended). Unit shall be certified to UL 399 and CAN/CSA C22.2 No. 120.

Compact, highly efficient water chiller units are designed for use with any drinking fountain. Also connects to a bubbler, glass filler or cold water dispenser. Converts a fountain into a water cooler.

<b>Order ID:</b>	SJ2
<b>Finish:</b>	Galvanized Steel
<b>Power:</b>	115V/60Hz
<b>Chilling Option*:</b>	2.0 GPH
<b>Full Load Amps</b>	3
<b>Rated Watts:</b>	185
<b>Dimensions:</b>	13-1/2" x 10-1/2" x 17-1/2"
<b>Approx. Shipping Weight:</b>	44 lbs.
<b>Installation Location:</b>	Indoor
<b>No. of Stations Served:</b>	1
*Based on 80° F inlet water & 90° F ambient air temp for 50° F chilled drinking water.	

**CONSTRUCTION**

- Cabinet: Rust-resistant galvanized steel

**COOLING SYSTEM**

- Compressor: Hermetically-sealed, reciprocating type, single phase. Sealed-in lifetime lubrication.
- Condenser: Fan cooled, copper tube with aluminum fins. Fan motor is permanently lubricated.
- Cooling Unit: Combination tube-tank type. Continuous copper tubing is fully insulated with foam that meets UL requirements for self-extinguishing material.
- Refrigerant Control: Refrigerant R134a is controlled by accurately calibrated capillary tube.
- Temperature Control: Easily accessible enclosed adjustable thermostat is factory preset. Requires no adjustment other than for altitude requirements.



AMERICAN PRIDE. A LIFETIME TRADITION. Like your family, the Elkay family has values and traditions that endure. For almost a century, Elkay has been a family-owned and operated company, providing thousands of jobs that support our families and communities.



**Included with Product:** Water Chiller

**PRODUCT COMPLIANCE**

Buy American Act  
CAN/CSA C22.2 No. 120  
UL 399



[Installation Instructions \(PDF\)](#)

**5 Year Limited Warranty** on the refrigeration system of the unit. Electrical components and water system are warranted for 12 months from date of installation. **Warranty pertains to drinking water applications only. Non-drinking water applications are not covered under warranty.**

[Warranty \(PDF\)](#)

**OPTIONAL ACCESSORIES**

732710751550 - Halsey Taylor Chiller Wall Shelf
734261251550 - Halsey Taylor Chiller Wall Box

PART: \_\_\_\_\_ QTY: \_\_\_\_\_  
 PROJECT: \_\_\_\_\_  
 CONTACT: \_\_\_\_\_  
 DATE: \_\_\_\_\_  
 NOTES: \_\_\_\_\_  
 APPROVAL: \_\_\_\_\_

*In keeping with our policy of continuing product improvement, Halsey Taylor reserves the right to change product specifications without notice. Please visit Halseytaylor.com for the most current version of Halsey Taylor product specification sheets. This specification describes a Halsey Taylor product with design, quality, and functional benefits to the user. When making a comparison of other producers' offerings, be certain these features are not overlooked.*

**Operating Pressures:**

Supply water - recommended water pressure range is 40-105 psi

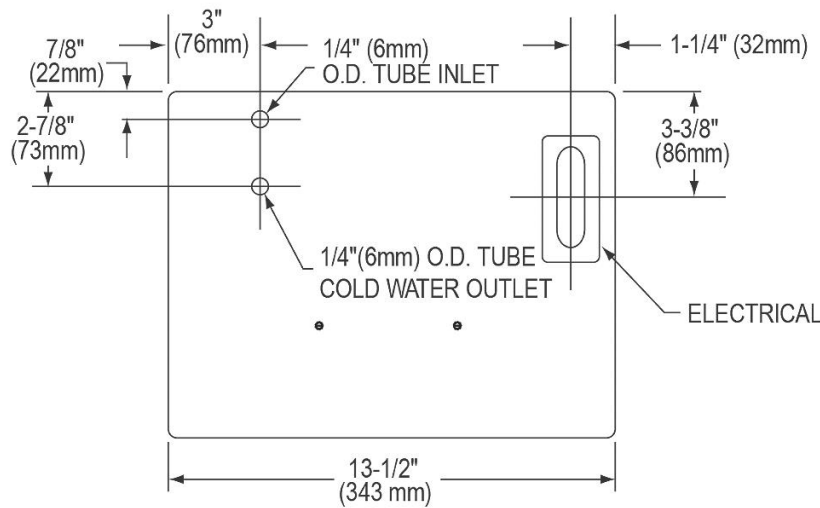

**TOP VIEW**

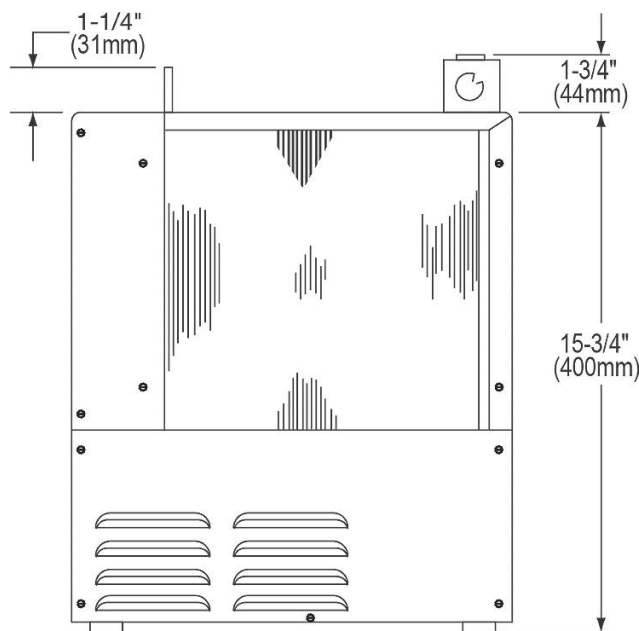

**FRONT VIEW**

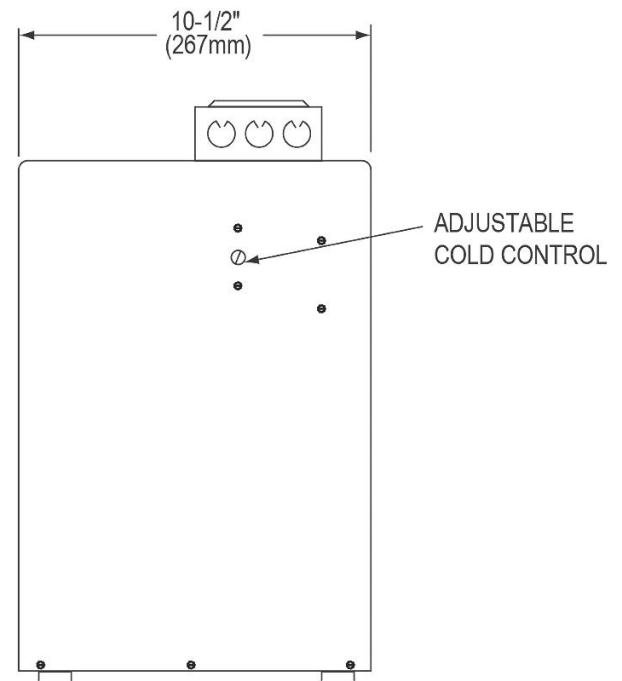

**SIDE VIEW**

NOTE: It is important to insure proper ventilation. Allow a minimum clearance of 6" (152 mm) in front and 3" (76 mm) in the rear of the unit. If unit is to be installed in an enclosure, allow the following clearances around unit: 1" (25 mm) each side, 3" (76 mm) in the rear, 3" (76 mm) above.

This chiller has been designed for use with potable water ONLY.

*In keeping with our policy of continuing product improvement, Halsey Taylor reserves the right to change product specifications without notice. Please visit [Halseytaylor.com](http://Halseytaylor.com) for the most current version of Halsey Taylor product specification sheets. This specification describes a Halsey Taylor product with design, quality, and functional benefits to the user. When making a comparison of other producers' offerings, be certain these features are not overlooked.*