

SECTION S – DOUBLE OFFSET HIGH PERFORMANCE BUTTERFLY VALVES

Table of Contents

DESCRIPTION	PAGE
Standard Compliance/Certifications	S-2
Advantages.....	S-3
Soft Seat Exploded View	S-4
Fire Safe Seat Exploded View	S-5
CLASS 150 DIMENSIONS	
215L Series (Lug Style)	S-6
215W Series (Wafer Style)	S-6
CLASS 300 DIMENSIONS	
230L Series (Lug Style)	S-7
230W Series (Wafer Style)	S-7
CLASS 600 DIMENSIONS	
260L Series (Lug Style)	S-8
260W Series (Wafer Style)	S-8
Handle & Worm Gear Dimensions - Soft & UHMWPE Seat	S-9
Handle & Worm Gear Dimensions - Fire Safe Seat.....	S-10
Flow Data	S-11
Torque Constants	S-12
Weights	S-13
Pressure Temperature Ratings	S-14-15
How to Specify	S-16
Warranty and Limitations of Liability	S-16

SECTION S – DOUBLE OFFSET HIGH PERFORMANCE BUTTERFLY VALVES

Standard Compliance/Certifications

STANDARD COMPLIANCE:

ASME B16.10	"Face to Face and End to End Dimensions of Valves"
ASME B16.34	"Valves - Flanged, Threaded, and Welding End"
ASME B16.5	"Pipe Flanges and Flanged Fittings"
ANSI/FCI 70-2	"For Control Valve Seat Leakage"
MSS SP-25	"Standard Marking System for Valves"
MSS SP-44	"Steel Pipe Line Flanges"
MSS SP-55	"Quality Standards for Steel Castings"
MSS SP-61	"Pressure Testing of Steel Valves"
MSS SP-68	"High Pressure Butterfly Valves with Offset Design"
API 598	American Petroleum Institute - "Valve Inspection and Testing"
API 607 - 6 th edition	American Petroleum Institute - "Fire Test for Soft Seated Valves"
API 609	American Petroleum Institute - "Butterfly Valves: Double Flanged, Lug and Wafer Type"
NSF/ANSI 61	"Drinking Water System Components - Health Effects" (2" - 24", Stainless 215 & 230)
NSF/ANSI 372	"Drinking Water System Components - Lead Content" (2" - 24", Stainless 215 & 230)

CERTIFICATIONS:

CE marked and documented valves that conform to the European Pressure Equipment Directive (PED) 97/23/EC are available in ANSI Class 150/300, both standard and fire safe configurations.

CRN No. 0C17459.5CL

SERVICES:

VACUUM SERVICE

Standard Apollo high performance butterfly valves are rated for 29" Hg vacuum.

STEAM SERVICE

The Apollo high performance butterfly valve is well-suited for a wide range of steam applications. The application range is defined in the high performance butterfly valve pressure-temperature charts.



LEAD FREE: The wetted surfaces of this product shall contain no more than 0.25% lead by weighted average. Complies with Federal Public Law 111-380. ANSI 3rd party approved and listed.

SECTION S – DOUBLE OFFSET HIGH PERFORMANCE BUTTERFLY VALVES

Advantages

ISO 5211 Mounting Flange

Universal mounting dimensions simplify valve actuation. Allows for direct mounting of several actuators.

Rocker Packing Gland

Shaped packing gland compensates for uneven adjustment of gland nuts.

Stem Packing

V-ring PTFE or flat graphite provides positive sealing.

Extended Neck

Allows for 2" of pipe insulation.

Body

Robust one-piece casting in WCB carbon steel or CF8M stainless steel. Available in wafer & lug style.

Positive Cast Disc Stop

Prevents seat damage from over-travel of the disc beyond the closed position. (not visible)

Jacking Taps

Allows the use of seat retainer bolts to aid in retainer removal.

Seat Retainer

Reliable multi-bolt retainer holds and supports the seat. Standard valves are suitable for bi-directional dead-end service at the full pressure-temperature rating of the valve. Same material as body material.

Corrosion Protection

Polyamide epoxy primer with high performance polyurethane topcoat is the standard finish for carbon steel valve bodies.

Stem (blowout proof)

17-4 PH stainless steel stem with high strength, and good corrosion resistance. Designed per API 609 standard.

Anti-Extrusion Ring (under stem seals)

Prevents the extrusion of stem seals, maintaining optimum seal.

Bearing (upper)

Full length provides maximum stem support. Made of 316 SS/PTFE

Seat

An advanced free floating, pressure assisted, solid seat design provides an interference and pressure assisted seal. This creates a positive seal under both low and high pressure requirements. The seat does not rely on any secondary components to hold it in place, assuring longer service life with less maintenance.

Tangential Disc Pins

17-4 PH stainless steel disc pins are tangentially positioned, placing them in compression rather than shear. This robust joint design eliminates potential failure of the disc-stem connection.

Disc

Standard material is 316 stainless steel.

Bearing (lower)

Full length provides maximum stem support. Made of 316 SS/PTFE

Thrust Ring

Centers the disc. Ensures tight shutoff and long service life. Made of 316 SS.

End Cap Seal

Made of PTFE or graphite.

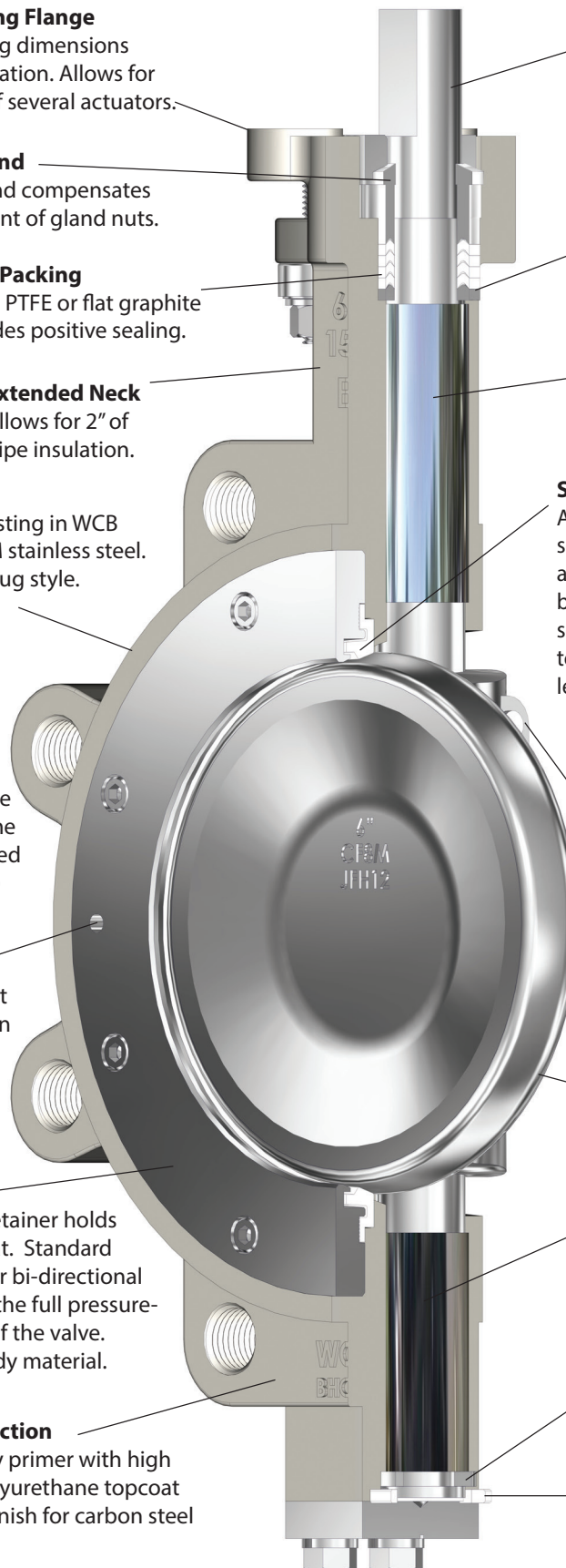

SOFT SEAT EXPLODED VIEW

Double Offset High Performance Butterfly Valves

Class 150 - 2" through 24", 30", 36" | Class 300 - 2" through 24" | Class 600 - 3" through 12"

STANDARD MATERIAL LIST

	PART	MATERIAL
1	Body	A351-CF8M or A216-WCB
2	Disc	A351-CF8M
3	Seat	TFM modified PTFE* w/ reinforced glass added
4	Seat Retainer	A351-CF8M or A216-WCB
5	Seat Retainer Bolt	Stainless Steel 316
6	Stem	17-4PH
7	Disc Pin	17-4PH
8	End Cap Bolt	Stainless Steel 316
9	Washer	Stainless Steel 316
10	End Cap	A351-CF8M or A216-WCB
11	Spacer	PTFE
12	End Cap Seal	PTFE
13	Thrust Ring	Stainless Steel 316
14	Lower Bearing	Stainless Steel 316/PTFE
15	Upper Bearing	Stainless Steel 316/PTFE
16	Anti-Extrusion Ring	Stainless Steel 316
17	Stem Packing	PTFE
18	Packing Gland	Stainless Steel 316
19	Gland Nut	Stainless Steel 316
20	Washer	Stainless Steel 316
21	Disc Spring	Stainless Steel 304
22	Disc Spring Retainer	Stainless Steel 316
23	Gland Studs	Stainless Steel 316
24	Gland Plate	A351-CF8M or A216-WCB

* Standard TFM™ modified PTFE is a next-generation PTFE with improved properties. Added glass further improves the seat providing greater wear resistance and a higher modulus.

NOTE: Class 150 Size 10" & larger have keyed stem.
Class 300 Size 8" & larger have keyed stem.
Class 600 Size 6" & larger have keyed stem.

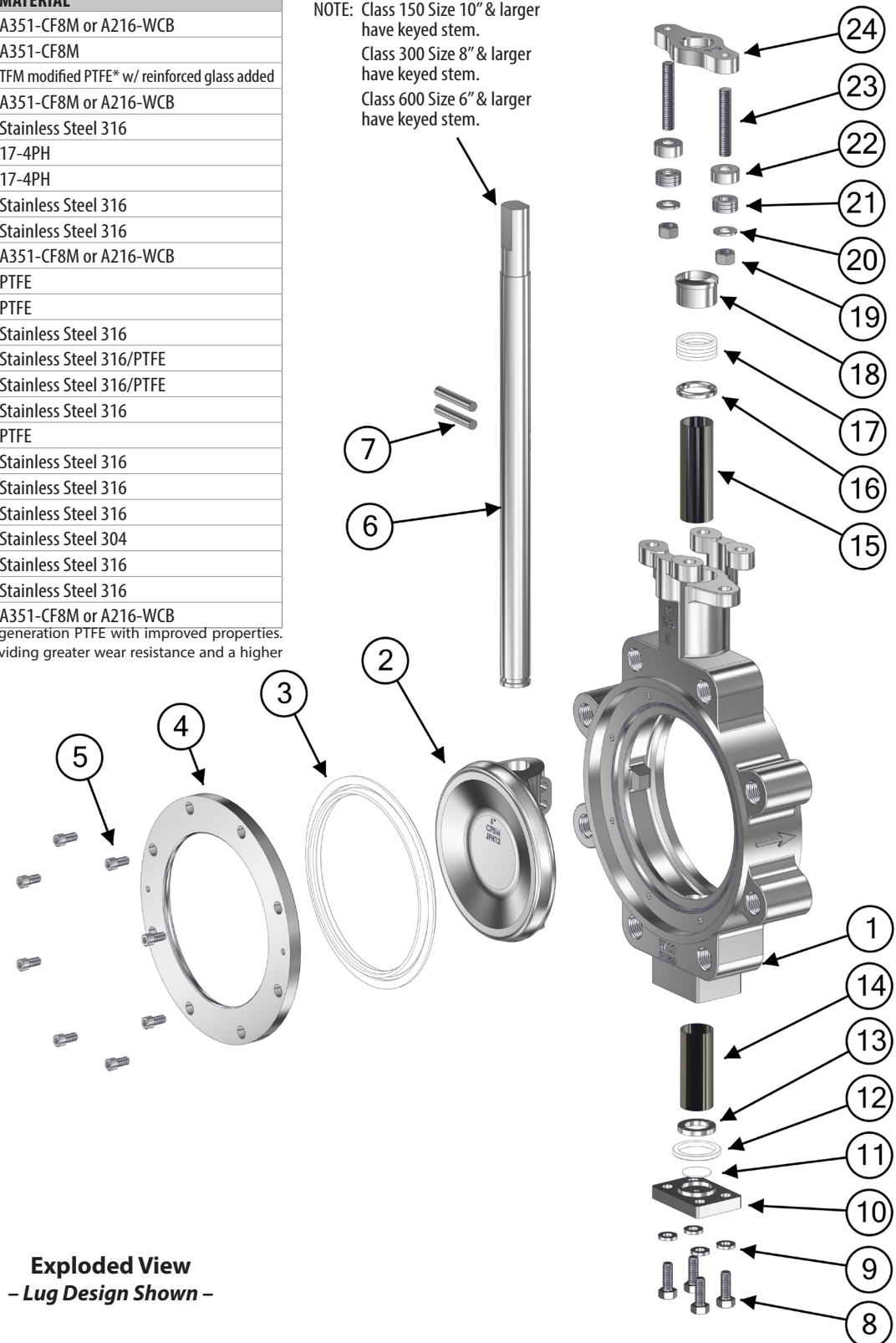

Exploded View
- Lug Design Shown -

FIRE SAFE SEAT EXPLODED VIEW

Double Offset High Performance Butterfly Valves

Class 150 - 2" through 24" | Class 300 - 2" through 24" | Class 600 - 3" through 12"

STANDARD MATERIAL LIST

	PART	MATERIAL
1	Body	A351-CF8M or A216-WCB
2	Disc	A351-CF8M
3	Body Seal	Graphite
4	Metal Seat	Inconel 718
5	Seat	TFM modified PTFE* w/ reinforced glass added
6	Seat Retainer	A351-CF8M or A216-WCB
7	Seat Retainer Bolt	Stainless Steel 316
8	Stem	17-4PH
9	Disc Pin	17-4PH
10	End Cap Bolt	Stainless Steel 316
11	Washer	Stainless Steel 316
12	End Cap	A351-CF8M or A216-WCB
13	Spacer	Stainless Steel 316
14	End Cap Seal	Graphite
15	Thrust Ring	Stainless Steel 316
16	Lower Bearing	Stainless Steel 316/PTFE
17	Upper Bearing	Stainless Steel 316/PTFE
18	Anti-Extrusion Ring	Stainless Steel 316
19	Stem Packing	Graphite
20	Packing Gland	Stainless Steel 316
21	Gland Nut	Stainless Steel 316
22	Washer	Stainless Steel 316
23	Disc Spring	Stainless Steel 304
24	Disc Spring Retainer	Stainless Steel 316
25	Gland Studs	Stainless Steel 316
26	Gland Plate	A351-CF8M or A216-WCB

* Standard TFM™ modified PTFE is a next-generation PTFE with improved properties. Added glass further improves the seat providing greater wear resistance and a higher modulus.

NOTE: Class 150 Size 10" & larger have keyed stem.
Class 300 Size 8" & larger have keyed stem.
Class 600 Size 6" & larger have keyed stem.

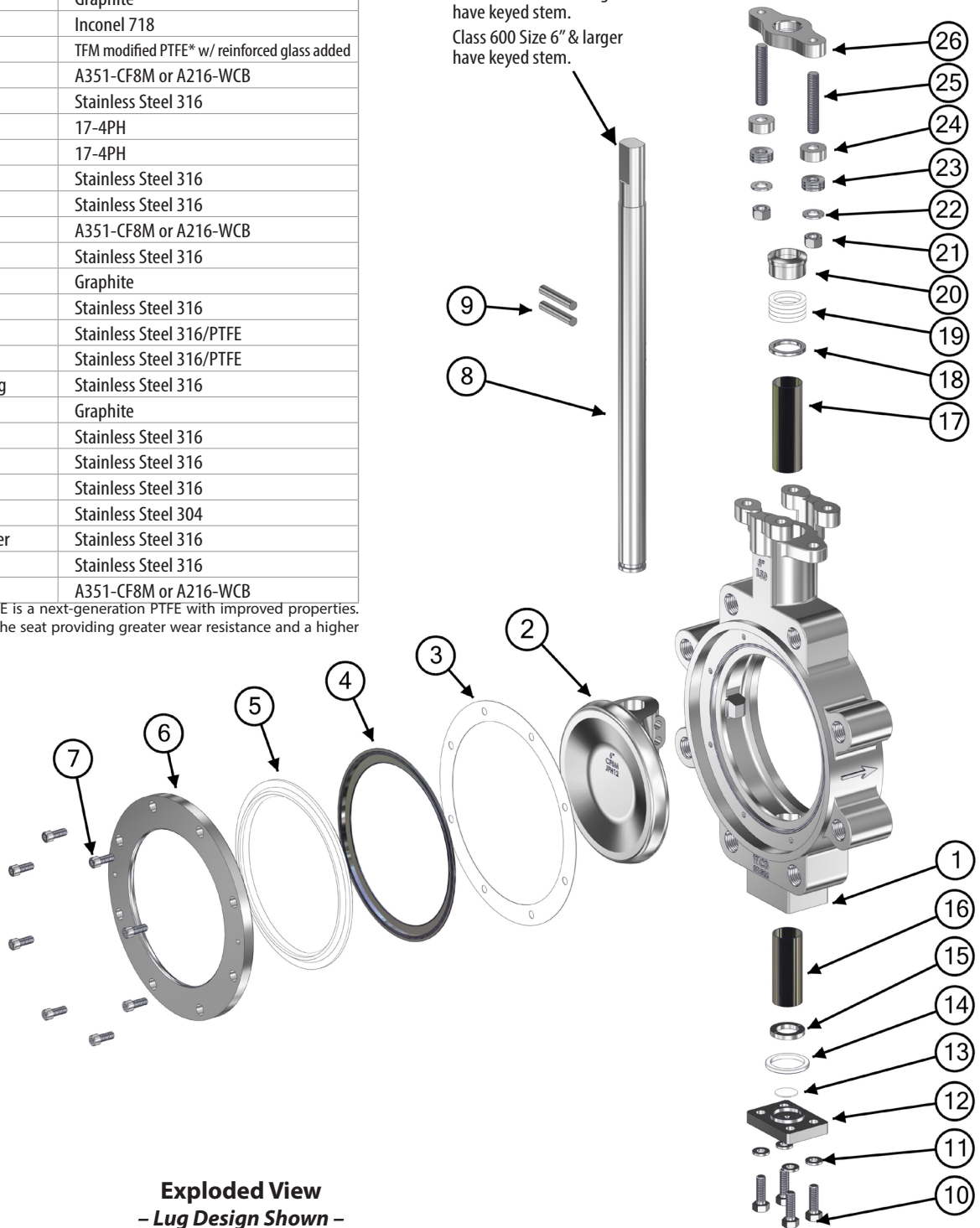

Exploded View
- Lug Design Shown -

215L/215W SERIES

Double Offset High Performance Butterfly Valves - Class 150 - 2" through 24", 30", 36"

For STANDARD COMPLIANCE and ADVANTAGES refer to pages 2-3.

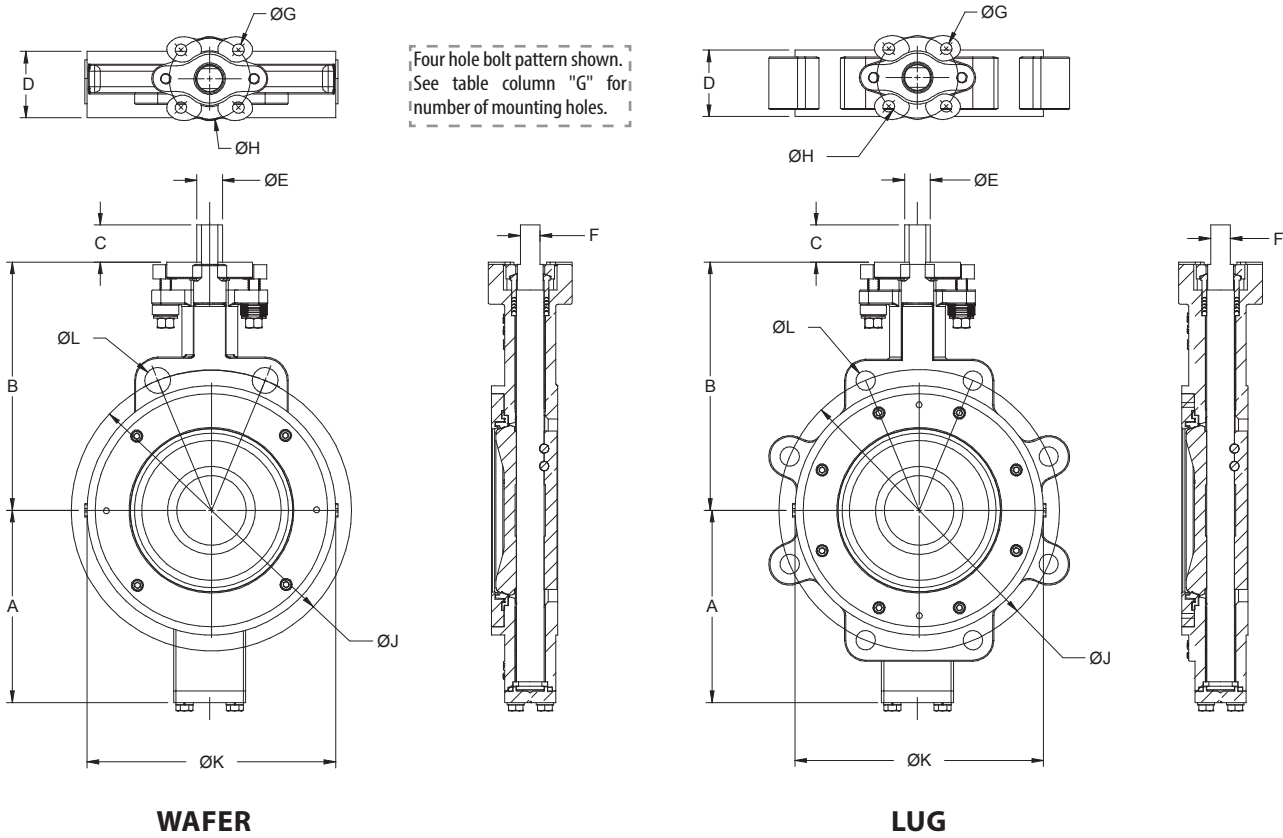

150 CLASS DOUBLE-D AND KEYED STEM

SIZE INCHES	SIZE DN	DIMENSIONS IN INCHES											ØL Wafer	ØL Lug
		A	B	C	D	ØE	F	KEY	ØG	ØH**	ØJ	ØK		
2	50	3.622	5.276	1.102	1.693	0.476	0.354	--	4 x 0.394	2.756 (F07)	4.75	4.09	2 x 0.669	4x5/8"-11UNC-2B
2.5	65	4.016	5.787	1.102	1.850	0.555	0.433	--	4 x 0.394	2.756 (F07)	5.50	4.72	2 x 0.748	4x5/8"-11UNC-2B
3	80	4.331	6.142	1.102	1.890	0.555	0.433	--	4 x 0.394	2.756 (F07)	6.00	4.92	2 x 0.748	4x5/8"-11UNC-2B
4	100	4.764	7.008	1.260	2.126	0.713	0.551	--	4 x 0.394	2.756 (F07)	7.50	6.10	2 x 0.748	8x5/8"-11UNC-2B
5	125	5.591	7.598	1.260	2.244	0.874	0.669	--	4 x 0.394	2.756 (F07)	8.50	7.24	2 x 0.874	8x3/4"-10UNC-2B
6	150	6.496	8.386	1.259	2.244	0.874	0.669	--	4 x 0.394	2.756 (F07)	9.50	8.43	2 x 0.874	8x3/4"-10UNC-2B
8	200	7.165	9.449	1.260	2.520	0.992	0.748	--	4 x 0.551	4.921 (F12)	11.75	10.55	2 x 0.874	8x3/4"-10UNC-2B
10	250	8.386	10.827	2.165	2.795	1.102	--	0.313	4 x 0.551	4.921 (F12)	14.25	12.68	2 x 0.984	12x7/8"-9UNC-2B
12	300	10.236	12.283	2.165	3.189	1.417	--	0.375	4 x 0.551	4.921 (F12)	17.00	14.92	2 x 0.984	12x7/8"-9UNC-2B
14	350	11.811	13.307	2.559	3.622	1.654	--	0.437	4 x 0.709	5.512 (F14)	18.75	16.14	2 x 1.118	12x1"-8UNC-2B
16	400	13.307	15.354	3.150	4.016	1.969	--	0.500	4 x 0.866	6.496 (F16)	21.25	18.43	2 x 1.118	16x1"-8UNC-2B
18	450	14.803	16.732	3.149	4.488	1.969	--	0.500	4 x 0.866	6.496 (F16)	22.75	20.94	4 x 1.240	16x1-1/8"-8UN-2B
20	500	15.748	17.717	4.331	5.000	2.362	--	0.625	4 x 0.866	6.496 (F16)	25.00	22.99	4x1-1/8"-8UN-2B	20x1-1/8"-8UN-2B
24	600	18.622	20.787	4.331	6.063	2.559	--	0.750	8 x 0.748	10.000 (F25)	29.50	27.24	4x1-1/4"-8UN-2B	20x1-1/4"-8UN-2B
*30	750	23.228	25.315	4.331	7.480	3.150	--	0.875	8 x 0.748	10.000 (F25)	36.00	36.42	--	28X1-1/4"-8UN-2B
*36	850	26.575	28.740	4.331	7.992	3.150	--	0.875	8 x 0.906	11.732 (F30)	42.75	45.28	--	32X1-1/2"-8UN-2B

*30" & 36" are Class 150 Lug Style only.

**ISO 5211 mounting/drilling pattern (F size) shown in parentheses.

230L/230W SERIES

Double Offset High Performance Butterfly Valves - Class 300 - 2" through 24"

For **STANDARD COMPLIANCE** and **ADVANTAGES** refer to pages 2-3.

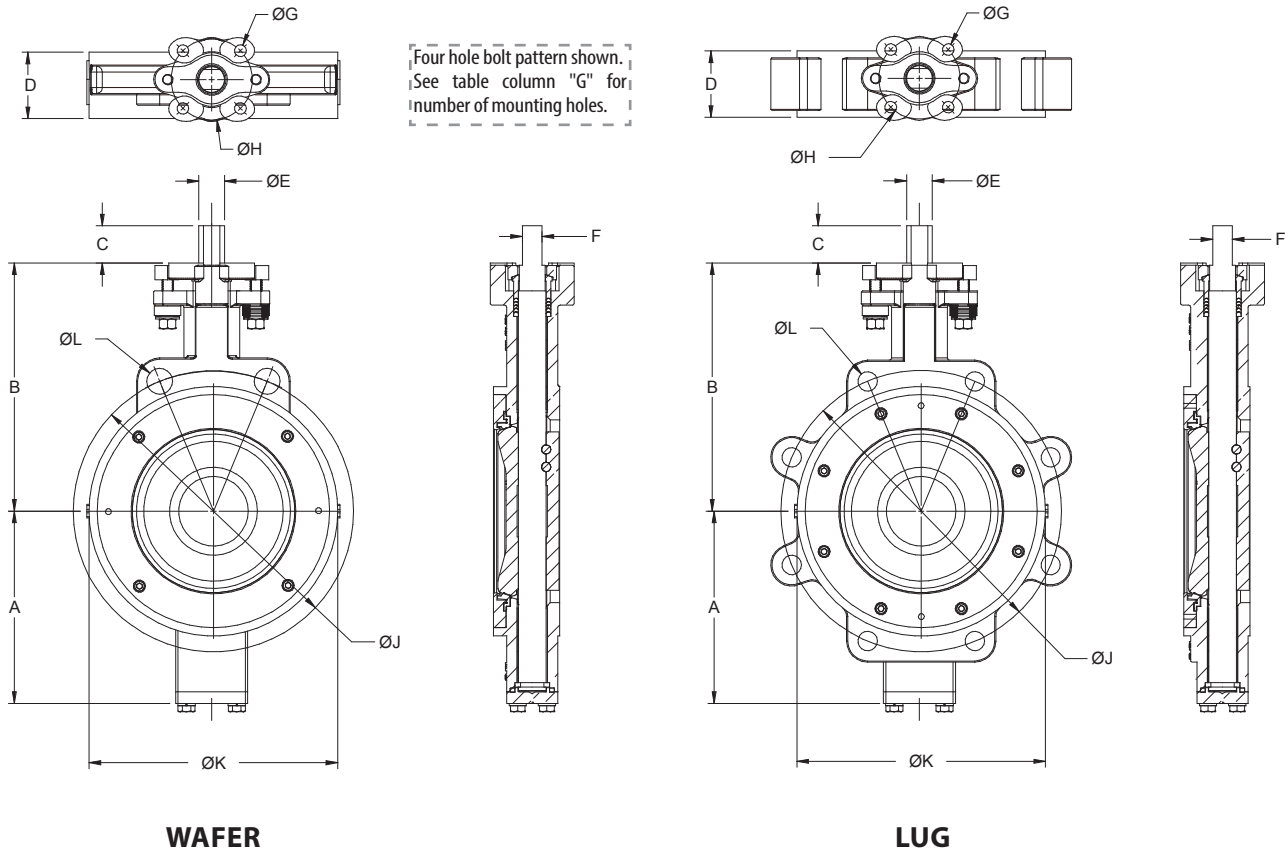

300 CLASS DOUBLE-D AND KEYED STEM

SIZE INCHES	SIZE DN	DIMENSIONS IN INCHES											ØL Wafer	ØL Lug
		A	B	C	D	ØE	F	KEY	ØG	ØH**	ØJ	ØK		
2	50	3.622	5.276	1.102	1.693	0.476	0.354	--	4 x 0.394	2.756 (F07)	5.00	4.17	2 x 0.709	8x5/8"-11UNC-2B
2.5	65	4.016	5.787	1.102	1.850	0.555	0.433	--	4 x 0.394	2.756 (F07)	5.88	4.72	2 x 0.874	8x3/4"-10UNC-2B
3	80	4.331	6.142	1.102	1.890	0.555	0.433	--	4 x 0.394	2.756 (F07)	6.62	4.92	2 x 0.874	8x3/4"-10UNC-2B
4	100	4.764	7.008	1.260	2.126	0.713	0.551	--	4 x 0.394	2.756 (F07)	7.88	6.10	2 x 0.874	8x3/4"-10UNC-2B
5	125	5.591	7.598	1.260	2.244	0.874	0.669	--	4 x 0.472	4.016 (F10)	9.25	7.24	2 x 0.874	8x3/4"-10UNC-2B
6	150	6.496	8.386	1.259	2.323	0.874	0.669	--	4 x 0.472	4.016 (F10)	10.62	8.43	2 x 0.874	12x3/4"-10UNC-2B
8	200	8.268	10.157	2.165	2.874	1.102	--	0.313	4 x 0.551	4.921 (F12)	13.00	10.55	2 x 0.984	12x7/8"-9UNC-2B
10	250	9.449	11.417	2.165	3.268	1.417	--	0.375	4 x 0.551	4.921 (F12)	15.25	12.72	4 x 1"-8UNC-2B	16x1"-8UNC-2B
12	300	10.63	12.795	2.559	3.662	1.654	--	0.437	4 x 0.709	5.512 (F14)	17.75	15.04	4x1-1/8"-8UN-2B	16x1-1/8"-8UN-2B
14	350	12.756	14.764	3.150	4.606	1.969	--	0.500	4x0.866	6.496 (F16)	20.25	16.14	4x1-1/8"-8UN-2B	20x1-1/8"-8UN-2B
16	400	14.37	16.732	3.149	5.236	1.969	--	0.500	4x0.866	6.496 (F16)	22.50	18.43	4x1-1/4"-8UN-2B	20x1-1/4"-8UN-2B
18	450	16.043	18.209	4.331	5.866	2.362	--	0.625	8x0.748	10.000 (F25)	24.75	20.94	4x1-1/4"-8UN-2B	24x1-1/4"-8UN-2B
20	500	17.795	19.882	4.331	6.260	2.835	--	0.750	8x0.748	10.000 (F25)	27.00	22.99	4x1-1/4"-8UN-2B	24x1-1/4"-8UN-2B
24	600	20.315	22.835	4.331	7.126	3.150	--	0.875	8x0.748	10.000 (F25)	32.00	27.24	4x1-1/2"-8UN-2B	24x1-1/2"-8UN-2B

** ISO 5211 mounting/drilling pattern (F size) shown in parentheses.

260L/260W SERIES

Double Offset High Performance Butterfly Valves - Class 600 - 3" through 12"

For **STANDARD COMPLIANCE** and **ADVANTAGES** refer to pages 2-3.

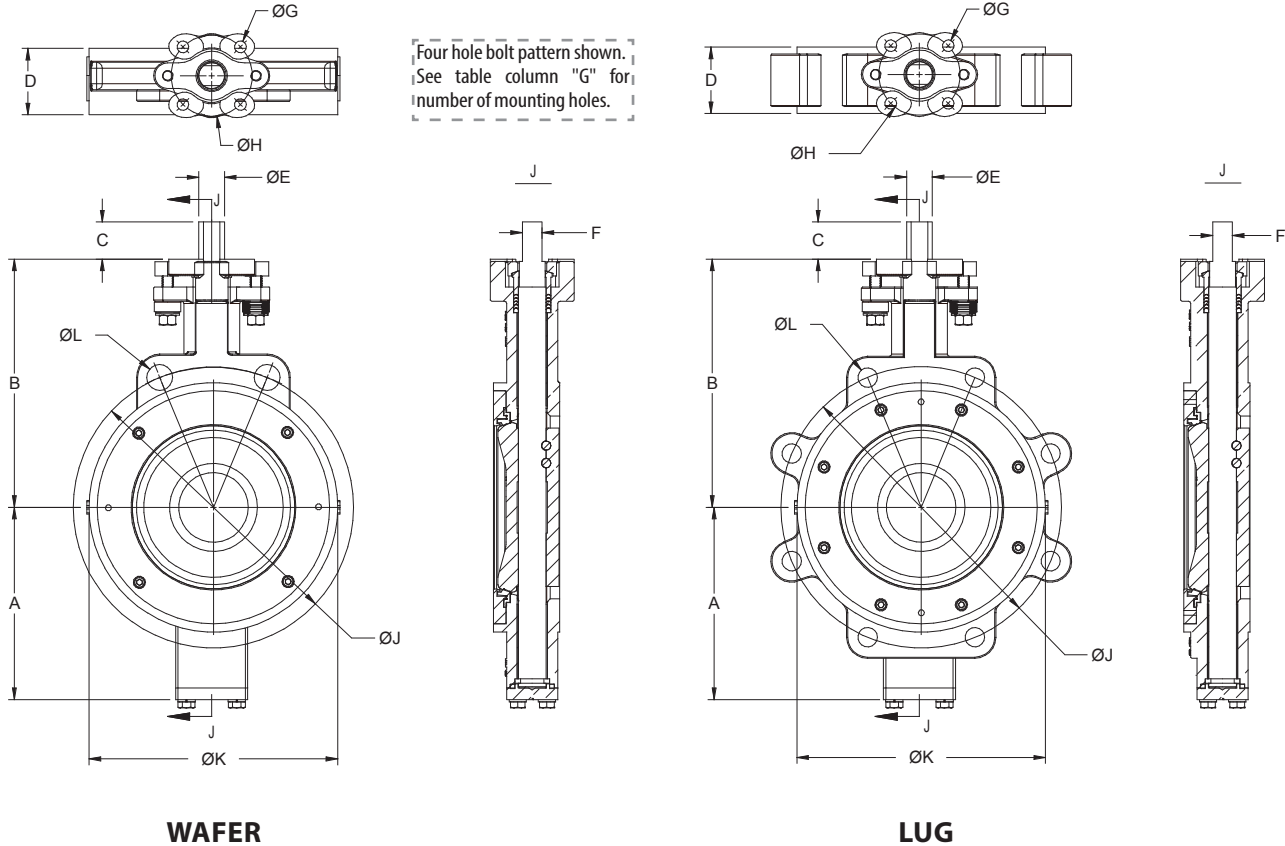

600 CLASS DOUBLE-D AND KEYED STEM

SIZE INCHES	SIZE DN	DIMENSIONS IN INCHES											ØL Wafer	ØL Lug
		A	B	C	D	ØE	F	KEY	ØG	ØH**	ØJ	ØK		
3	80	4.705	6.496	1.260	2.126	0.713	0.551	--	4 x 0.394	2.756 (F07)	6.62	5.71	2 x 0.866	8 x 3/4"-10 UNC-2B
4	100	5.748	7.717	1.260	2.520	0.874	0.669	--	4 x 0.551	4.921 (F12)	8.50	6.85	2 x 0.984	8 x 7/8"-9 UNC-2B
6	150	7.953	9.724	2.165	3.071	1.417	--	0.375	4 x 0.551	4.921 (F12)	11.50	9.45	4 x 1"-8UNC-2B	12 x 1"-8 UNC-2B
8	200	9.528	11.614	3.150	4.016	1.890	--	0.500	4 x 0.906	6.496 (F16)	13.75	11.65	4 x 1-1/8"-8UN-2B	12 x 1-1/8"-8UN-2B
10	250	11.024	13.386	3.150	4.606	1.969	--	0.500	4 x 0.906	6.496 (F16)	17.00	13.86	4 x 1-1/4"-8UN-2B	16 x 1-1/4"-8UN-2B
12	300	12.913	15.354	4.331	5.512	2.362	--	0.625	8 x 0.709	10.000 (F25)	19.25	16.34	4 x 1-1/4"-8UN-2B	20 x 1-1/4"-8UN-2B

(5" size not available)

** ISO 5211 mounting/drilling pattern (F size) shown in parentheses.

HANDLE & GEAR DIMENSIONS – SOFT & UHMWPE SEAT

Double Offset High Performance Butterfly Valves

Class 150 – Soft & UHMWPE Seat

Valve Size		Gear Ratio	Dimensions in Inches						
Inches	DN		A	B	C	D	E	F	G
2"	50	37:1	2.24	2.11	7.87	11.81	2.09	1.14	8.82
2.5"	65	37:1	2.24	2.11	7.87	11.81	2.09	1.14	8.82
3"	80	37:1	2.24	2.11	7.87	11.81	2.09	1.14	8.82
4"	100	37:1	2.24	2.11	7.87	11.81	2.09	1.14	12.82
5"	125	37:1	2.24	2.11	7.87	11.81	2.09	1.14	12.82
6"	150	37:1	2.24	2.11	7.87	11.81	2.09	1.14	12.82
8"	200	37:1	2.76	2.11	10.94	11.81	2.09	1.50	22.00
10"	250	37:1	2.76	2.11	10.94	11.81	2.09	1.50	22.00
12"	300	34:1	3.43	2.50	12.87	11.81	2.80	1.59	22.00
14"	350	55:1	4.06	4.39	13.07	15.75	4.11	1.93	—
16"	400	55:1	4.06	4.39	13.07	15.75	4.11	1.93	—
18"	450	55:1	4.06	4.39	13.07	15.75	4.11	1.93	—
20"	500	55:1	4.06	4.39	13.07	15.75	4.11	1.93	—
24"	600	52:1	4.96	4.92	13.11	15.75	5.12	2.40	—
30"	750	70:1	6.65	7.48	18.90	24.00	7.00	3.54	—
36"	850	60:1	8.15	9.06	20.90	24.00	8.26	4.29	—

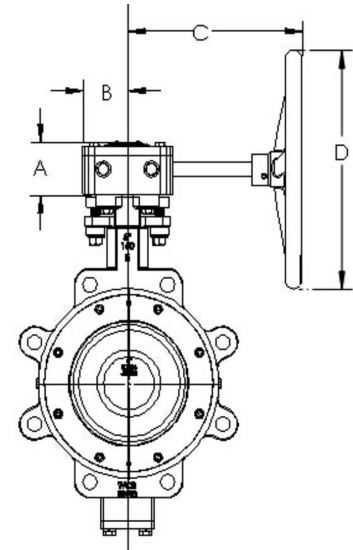

with Worm Gear

Class 300 – Soft & UHMWPE Seat

Valve Size		Gear Ratio	Dimensions in Inches						
Inches	DN		A	B	C	D	E	F	G
2"	50	37:1	2.24	2.11	7.87	11.81	2.09	1.14	8.82
2.5"	65	37:1	2.24	2.11	7.87	11.81	2.09	1.14	8.82
3"	80	37:1	2.24	2.11	7.87	11.81	2.09	1.14	8.82
4"	100	37:1	2.24	2.11	7.87	11.81	2.09	1.14	12.82
5"	125	37:1	2.76	2.11	10.94	11.81	2.09	1.50	12.82
6"	150	37:1	2.76	2.11	10.94	11.81	2.09	1.50	12.82
8"	200	34:1	3.43	2.50	12.87	11.81	2.80	1.59	22.00
10"	250	34:1	3.43	2.50	12.87	11.81	2.80	1.59	22.00
12"	300	55:1	4.06	4.39	13.07	15.75	4.11	1.93	—
14"	350	55:1	4.06	4.39	13.07	15.75	4.11	1.93	—
16"	400	55:1	4.06	4.39	13.07	15.75	4.11	1.93	—
18"	450	52:1	4.96	4.92	13.11	15.75	5.12	2.40	—
20"	500	70:1	6.65	7.48	18.90	24.00	7.00	3.54	—
24"	600	70:1	6.65	7.48	18.90	24.00	7.00	3.54	—

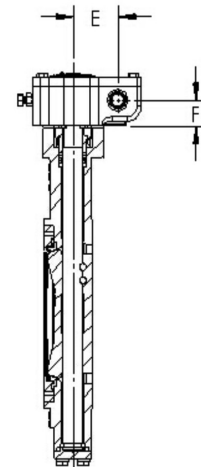

with Worm Gear

Class 600 – Soft Seat

Valve Size		Gear Ratio	Dimensions in Inches					
Inches	DN		A	B	C	D	E	F
3"	80	37:1	2.24	2.11	7.87	11.81	2.09	1.14
4"	100	37:1	2.76	2.11	10.94	11.81	2.09	1.50
6"	150	37:1	2.76	2.11	10.94	11.81	2.09	1.50
8"	200	55:1	4.06	4.39	13.07	15.75	4.11	1.93
10"	250	55:1	4.06	4.39	13.07	15.75	4.11	1.93
12"	300	52:1	4.96	4.92	13.11	15.75	5.12	2.40

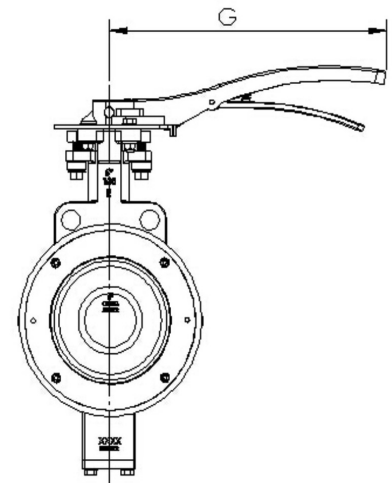

with Handle

HANDLE & GEAR DIMENSIONS – FIRE SAFE SEAT

Double Offset High Performance Butterfly Valves

Class 150 – Fire Safe Seat

Valve Size		Gear Ratio	Dimensions in Inches						
Inches	DN		A	B	C	D	E	F	G
2"	50	37:1	2.24	2.11	7.87	11.81	2.09	1.14	8.82
2.5"	65	37:1	2.24	2.11	7.87	11.81	2.09	1.14	8.82
3"	80	37:1	2.24	2.11	7.87	11.81	2.09	1.14	8.82
4"	100	37:1	2.24	2.11	7.87	11.81	2.09	1.14	12.82
5"	125	37:1	2.24	2.11	7.87	11.81	2.09	1.14	12.82
6"	150	37:1	2.24	2.11	7.87	11.81	2.09	1.14	12.82
8"	200	37:1	2.76	2.11	10.94	11.81	2.09	1.50	22.00
10"	250	34:1	3.43	2.50	12.87	11.81	2.80	1.59	22.00
12"	300	55:1	4.06	4.39	13.07	15.75	4.11	1.93	22.00
14"	350	55:1	4.06	4.39	13.07	15.75	4.11	1.93	—
16"	400	55:1	4.06	4.39	13.07	15.75	4.11	1.93	—
18"	450	52:1	4.96	4.92	13.11	15.75	5.12	2.40	—
20"	500	52:1	4.96	4.92	13.11	15.75	5.12	2.40	—
24"	600	70:1	6.65	7.48	18.90	24.00	7.00	3.54	—

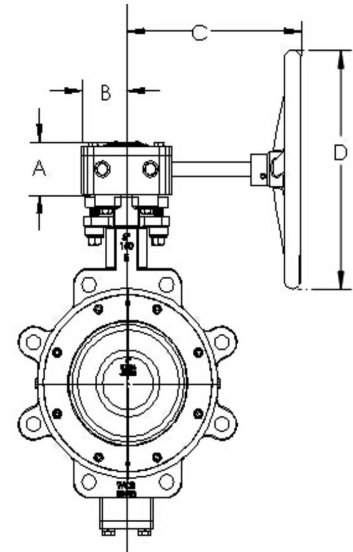

with Worm Gear

Class 300 – Fire Safe Seat

Valve Size		Gear Ratio	Dimensions in Inches						
Inches	DN		A	B	C	D	E	F	G
2"	50	37:1	2.24	2.11	7.87	11.81	2.09	1.14	8.82
2.5"	65	37:1	2.24	2.11	7.87	11.81	2.09	1.14	8.82
3"	80	37:1	2.24	2.11	7.87	11.81	2.09	1.14	8.82
4"	100	37:1	2.24	2.11	7.87	11.81	2.09	1.14	12.82
5"	125	37:1	2.76	2.11	10.94	11.81	2.09	1.50	12.82
6"	150	37:1	2.76	2.11	10.94	11.81	2.09	1.50	12.82
8"	200	34:1	3.43	2.50	12.87	11.81	2.80	1.59	22.00
10"	250	55:1	4.06	4.39	13.07	15.75	4.11	1.93	22.00
12"	300	55:1	4.06	4.39	13.07	15.75	4.11	1.93	—
14"	350	52:1	4.96	4.92	13.11	15.75	5.12	2.40	—
16"	400	52:1	4.96	4.92	13.11	15.75	5.12	2.40	—
18"	450	70:1	6.65	7.48	18.90	24.00	7.00	3.54	—
20"	500	70:1	6.65	7.48	18.90	24.00	7.00	3.54	—
24"	600	60:1	8.15	9.06	20.90	24.00	8.26	4.29	—

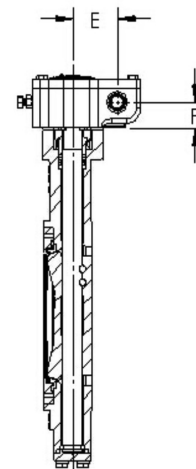

with Worm Gear

Class 600 – Fire Safe Seat

Valve Size		Gear Ratio	Dimensions in Inches					
Inches	DN		A	B	C	D	F	
3"	80	37:1	2.24	2.11	7.87	11.81	2.09	1.14
4"	100	34:1	3.43	2.50	12.87	11.81	2.80	1.59
6"	150	55:1	4.06	4.39	13.07	15.75	4.11	1.93
8"	200	55:1	4.06	4.39	13.07	15.75	4.11	1.93
10"	250	52:1	4.96	4.92	13.11	15.75	5.12	2.40
12"	300	832:1	8.86	5.91	15.04	17.72	9.02	3.23

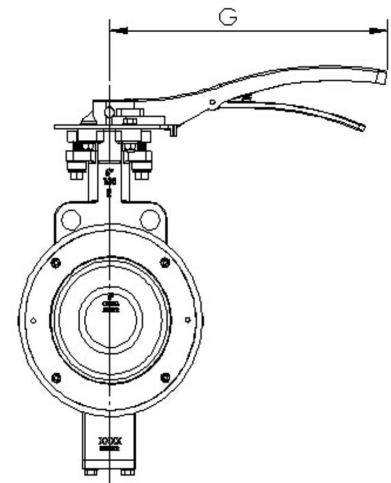

with Handle

FLOW DATA

Double Offset High Performance Butterfly Valves

Cv values (US gallons per minute) represent the flow of 60°F water through a 100% open valve at a pressure drop of 1 psi.

The metric equivalent, Kv, is the flow of water at 16°C through the valve in cubic meters per hour at a pressure drop of 1 kg/cm2. To convert Cv to Kv, multiply the Cv by 0.8569.

Rated Flow Coefficient (Cv) – 215L/215W

Size		Class	Angle of Disc Opening (Degrees)								
Inches	DN		10°	20°	30°	40°	50°	60°	70°	80°	90°
2"	50	150	2	5	12	18	30	45	62	81	89
2.5"	65	150	2.5	8	20	32	50	74	103	134	145
3"	80	150	4	13	30	46	76	108	156	194	212
4"	100	150	8	23	53	84	136	192	279	347	376
5"	125	150	15	43	102	160	261	371	539	669	728
6"	150	150	26	67	154	242	391	463	808	1004	1091
8"	200	150	53	126	296	466	761	1077	1567	1945	2134
10"	250	150	82	199	461	728	1188	1683	2444	3041	3298
12"	300	150	112	272	636	994	1630	2309	3346	4161	4559
14"	350	150	145	342	800	1258	2063	2921	4237	5268	5687
16"	400	150	195	464	1088	1708	2791	3958	5739	7135	7710
18"	450	150	252	600	1404	2204	3608	5108	7416	9215	9996
20"	500	150	323	778	1813	2848	4662	6606	9585	11914	12931
24"	600	150	472	1232	2878	4519	7393	10475	15199	18900	20551
30"	750	150	490	1550	3800	7650	11000	15850	21850	27450	30900
36"	850	150	520	2050	5200	9980	15000	22100	31950	43800	49650

Rated Flow Coefficient (Cv) – 230L/230W

Size		Class	Angle of Disc Opening (Degrees)								
Inches	DN		10°	20°	30°	40°	50°	60°	70°	80°	90°
2"	50	300	2	5	12	18	30	45	62	81	89
2.5"	65	300	2.5	8	20	32	50	74	103	134	145
3"	80	300	4	13	30	46	76	108	156	194	212
4"	100	300	8	23	53	84	136	192	279	347	376
5"	125	300	15	43	102	160	261	371	539	669	728
6"	150	300	25	62	145	227	371	526	764	950	1034
8"	200	300	44	107	252	398	650	917	1334	1659	1843
10"	250	300	73	170	403	631	1033	1460	2119	2638	2910
12"	300	300	100	238	551	865	1420	2009	2917	3624	3895
14"	350	300	128	309	717	1126	1843	2613	3786	4707	5130
16"	400	300	166	395	922	1446	2368	3352	4869	6053	6562
18"	450	300	233	561	1306	2057	3363	4764	6911	8593	9310
20"	500	300	284	686	1598	2510	4113	5824	8452	10506	11378
24"	600	300	413	1078	2513	3947	6460	9153	13281	16511	17955

Rated Flow Coefficient (Cv) – 260L/260W

Size		Class	Angle of Disc Opening (Degrees)								
Inches	DN		10°	20°	30°	40°	50°	60°	70°	80°	90°
3"	80	600	3	9	21	32	53	75	110	136	148
4"	100	600	5	15	33	52	85	122	176	220	238
6"	150	600	16	40	93	147	242	341	496	616	668
8"	200	600	32	75	171	268	429	621	904	1124	1177
10"	250	600	52	124	294	464	757	1071	1555	1931	2060
12"	300	600	70	165	379	599	978	1387	2011	2500	2695

This chart should be used as a general guide.

Cv = the volume of water in U.S. gallons per minute that will pass through a given valve opening with a pressure drop of 1 psig at room temperature.



TORQUE CONSTANTS

Double Offset High Performance Butterfly Valves

Soft & UHMWPE Seat – Torque Rating (In-Lbs)

SIZE	PSIG	CLASS 150				CLASS 300					CLASS 600					
		$\Delta P=100$	$\Delta P=150$	$\Delta P=200$	$\Delta P=285$	$\Delta P=100$	$\Delta P=150$	$\Delta P=200$	$\Delta P=285$	$\Delta P=740$	$\Delta P=150$	$\Delta P=500$	$\Delta P=800$	$\Delta P=1000$	$\Delta P=1200$	$\Delta P=1480$
2"	in-lbs	204	230	266	332	248	332	381	425	531	–	–	–	–	–	–
2.5"	in-lbs	239	283	319	398	301	398	443	478	575	–	–	–	–	–	–
3"	in-lbs	257	301	345	434	327	434	487	540	664	407	513	841	974	1,106	1,283
4"	in-lbs	398	469	531	664	469	664	761	867	1,106	620	841	1,540	1,823	2,106	2,487
5"	in-lbs	558	655	743	929	620	885	1,062	1,239	1,664	–	–	–	–	–	–
6"	in-lbs	726	850	974	1,212	858	1,221	1,505	1,779	2,460	974	1,363	2,593	3,089	3,575	4,248
8"	in-lbs	1,328	1,549	1,770	2,213	1,646	2,354	2,921	3,487	4,868	1,912	2,673	5,080	6,045	7,009	8,319
10"	in-lbs	2,213	2,575	2,947	3,682	2,575	3,682	4,691	5,699	8,142	3,177	4,437	8,434	10,036	11,638	13,806
12"	in-lbs	2,867	3,345	3,823	4,779	3,629	5,177	6,522	7,877	11,151	4,788	6,682	12,709	15,116	17,523	20,798
14"	in-lbs	4,938	5,761	6,584	8,231	6,053	8,646	11,186	13,735	19,913	–	–	–	–	–	–
16"	in-lbs	6,903	8,054	9,204	11,505	8,461	12,080	14,788	17,496	24,072	–	–	–	–	–	–
18"	in-lbs	9,717	11,337	12,956	16,196	11,903	17,010	20,461	23,913	32,303	–	–	–	–	–	–
20"	in-lbs	12,930	15,089	17,240	21,550	15,842	22,629	26,816	30,993	41,153	–	–	–	–	–	–
24"	in-lbs	19,859	23,169	26,479	33,099	24,329	34,754	40,595	46,436	60,623	–	–	–	–	–	–
30"	in-lbs	30,090	35,400	40,710	49,472	–	–	–	–	–	–	–	–	–	–	–
36"	in-lbs	48,233	58,145	68,057	84,849	–	–	–	–	–	–	–	–	–	–	–

Fire Safe Seat – Torque Rating (In-Lbs)

SIZE	PSIG	CLASS 150				CLASS 300					CLASS 600					
		$\Delta P=100$	$\Delta P=150$	$\Delta P=200$	$\Delta P=285$	$\Delta P=100$	$\Delta P=150$	$\Delta P=200$	$\Delta P=285$	$\Delta P=740$	$\Delta P=150$	$\Delta P=500$	$\Delta P=800$	$\Delta P=1000$	$\Delta P=1200$	$\Delta P=1480$
2"	in-lbs	434	504	584	726	504	726	770	814	929	–	–	–	–	–	–
2.5"	in-lbs	460	540	620	770	540	770	823	885	1,018	–	–	–	–	–	–
3"	in-lbs	584	681	779	974	681	974	1,035	1,097	1,257	866	1,208	1,549	1,788	2,027	2,354
4"	in-lbs	708	832	947	1,186	832	1,186	1,248	1,319	1,478	1,402	1,887	2,372	2,797	3,230	3,814
5"	in-lbs	965	1,124	1,283	1,602	1,133	1,620	1,894	2,177	2,850	–	–	–	–	–	–
6"	in-lbs	1,345	1,566	1,788	2,239	1,584	2,257	2,531	2,805	3,478	3,758	4,485	5,213	6,204	7,186	8,531
8"	in-lbs	2,089	2,443	2,788	3,487	2,513	3,584	4,160	4,735	6,133	7,077	8,455	9,832	11,691	13,558	16,089
10"	in-lbs	3,283	3,832	4,381	5,478	4,027	5,753	6,673	7,602	9,841	11,400	13,616	15,833	18,833	21,833	25,913
12"	in-lbs	5,168	6,036	6,894	8,620	6,230	8,894	10,470	12,045	15,877	17,542	20,949	24,355	28,975	33,595	39,869
14"	in-lbs	6,912	8,062	9,213	11,514	8,363	11,948	14,426	16,904	22,913	–	–	–	–	–	–
16"	in-lbs	8,770	10,231	11,700	14,620	10,655	15,222	18,682	22,152	30,559	–	–	–	–	–	–
18"	in-lbs	12,567	14,664	16,762	20,948	15,178	21,683	27,541	33,409	47,640	–	–	–	–	–	–
20"	in-lbs	16,859	19,674	22,479	28,099	20,196	28,851	37,993	47,126	69,322	–	–	–	–	–	–
24"	in-lbs	25,072	29,249	33,426	41,781	30,046	42,923	56,622	70,331	103,607	–	–	–	–	–	–

- Under certain conditions, hydrodynamic torque can meet or exceed seating and unseating torques. When designing valve systems, hydrodynamic torque must be considered to help ensure correct selection of actuation.
- All published double offset High Performance Butterfly Valve torque charts have a 10% safety factor included.

WEIGHTS

Double Offset High Performance Butterfly Valves

Soft & UHMWPE Seat

Valve Size		Class 150		Class 300		Class 600	
Inches	DN	Wafer Lbs (kg)	Lug Lbs (kg)	Wafer Lbs (kg)	Lug Lbs (kg)	Wafer Lbs (kg)	Lug Lbs (kg)
2"	50	9.2 (4.2)	10.9 (5.0)	9.2 (4.2)	12.2 (5.5)	—	—
2.5"	65	11.7 (5.3)	13.0 (5.9)	11.7 (5.3)	15.4 (7.0)	—	—
3"	80	12.4 (5.6)	14.2 (6.4)	12.4 (5.6)	17.7 (8.0)	18.2 (8.2)	22.5 (10.2)
4"	100	17.9 (8.1)	23.5 (10.7)	18.0 (8.2)	25.7 (11.6)	31.5 (14.3)	41.1 (18.6)
5"	125	24.0 (10.9)	31.0 (14.1)	25.3 (11.5)	34.9 (15.8)	—	—
6"	150	30.6 (13.9)	38.0 (17.2)	32.4 (14.7)	47.0 (21.2)	71.4 (32.4)	90.6 (41.1)
8"	200	46.7 (21.2)	56.3 (25.5)	60.0 (27.2)	82.8 (37.5)	136.6 (62.0)	167.1 (75.8)
10"	250	68.5 (31.1)	86.4 (39.2)	96.8 (43.9)	129.5 (58.7)	200.2 (90.8)	279.8(126.9)
12"	300	104.2 (47.3)	133.0 (60.3)	143.4 (65.0)	189.0 (85.7)	325.0 (147.4)	452.3 (205.2)
14"	350	138.7 (62.9)	183.3 (83.1)	218.0 (98.9)	325.0 (147.4)	—	—
16"	400	206.9 (93.8)	273.6 (124.1)	309.1 (140.2)	443.9 (201.4)	—	—
18"	450	278.9 (126.5)	340.6 (154.5)	438.7 (199.0)	634.7 (288.0)	—	—
20"	500	357.2 (162.0)	440.8 (199.9)	575.0 (260.8)	782.7 (355.0)	—	—
24"	600	574.3 (260.5)	709.4 (321.8)	840.2 (381.1)	1,201.9 (545.2)	—	—
30"	750	—	1,392.6 (633.0)	—	—	—	—
36"	850	—	2,142.8 (974.0)	—	—	—	—

Fire Safe Seat

Valve Size		Class 150		Class 300		Class 600	
Inches	DN	Wafer Lbs (kg)	Lug Lbs (kg)	Wafer Lbs (kg)	Lug Lbs (kg)	Wafer Lbs (kg)	Lug Lbs (kg)
2"	50	9.3 (4.2)	11.0 (5.0)	9.3 (4.2)	12.2 (5.5)	—	—
2.5"	65	11.8 (5.3)	13.0 (5.9)	11.8 (5.3)	15.5 (7.0)	—	—
3"	80	12.4 (5.6)	14.3 (6.5)	12.4 (5.6)	17.8 (8.1)	18.3 (8.3)	22.6 (10.2)
4"	100	18.0 (8.2)	23.6 (10.7)	18.1 (8.2)	25.8 (11.7)	31.7 (14.4)	41.3 (18.7)
5"	125	24.1 (10.9)	31.2 (14.1)	25.4 (11.5)	35.0 (15.9)	—	—
6"	150	30.8 (14.0)	38.2(17.3)	32.6 (14.8)	46.9 (21.3)	71.7 (32.5)	91.1 (41.3)
8"	200	47.0 (21.3)	56.6 (25.7)	60.3 (27.3)	83.1 (37.7)	137.3 (62.3)	168.0 (76.2)
10"	250	68.8 (31.2)	86.8 (39.4)	97.2 (44.1)	130.0 (59.0)	201.2 (91.3)	281.2 (127.5)
12"	300	104.8 (47.5)	133.6 (60.6)	143.9 (65.3)	189.8 (86.1)	326.7 (148.2)	454.6 (206.2)
14"	350	139.4 (63.3)	184.2 (83.5)	218.9 (99.3)	326.3 (148.0)	—	—
16"	400	207.9 (94.3)	275.0 (124.7)	310.3 (140.7)	445.7 (202.2)	—	—
18"	450	280.2 (127.1)	342.3 (155.3)	440.5 (199.8)	637.2 (289.0)	—	—
20"	500	359.0 (162.8)	443.0 (200.9)	577.3 (261.8)	785.9 (356.5)	—	—
24"	600	577.2 (261.8)	712.9 (323.4)	843.5 (382.62)	1,206.7 (547.4)	—	—

PRESSURE TEMPERATURE RATINGS

Class 150 – Double Offset High Performance Butterfly Valves

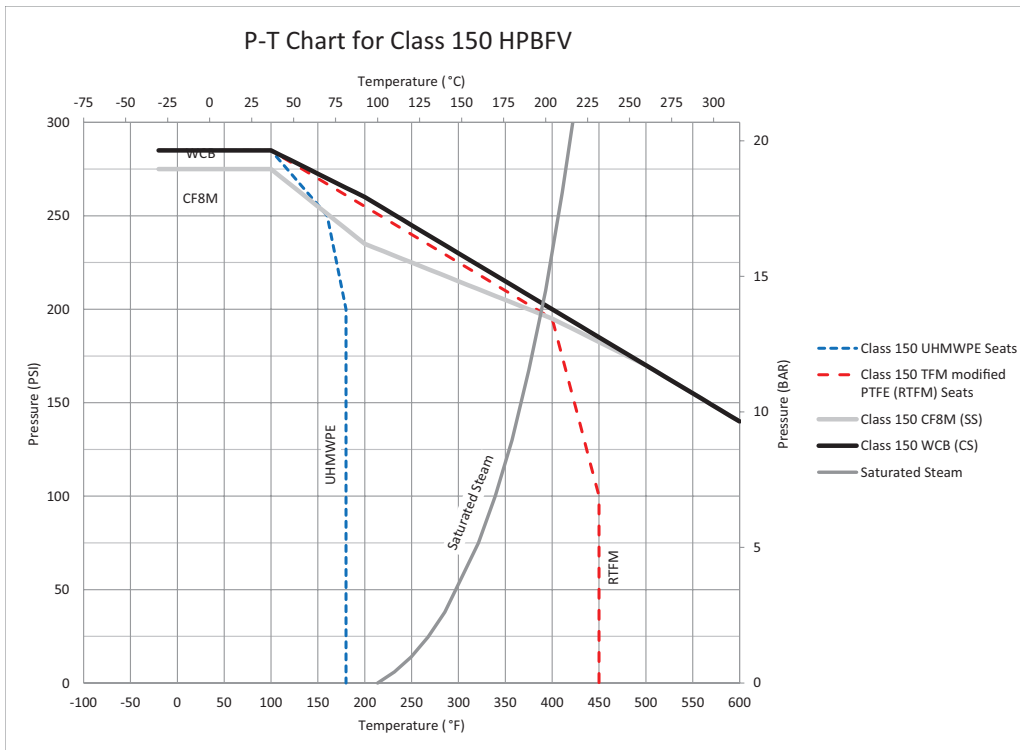

Class 300 – Double Offset High Performance Butterfly Valves

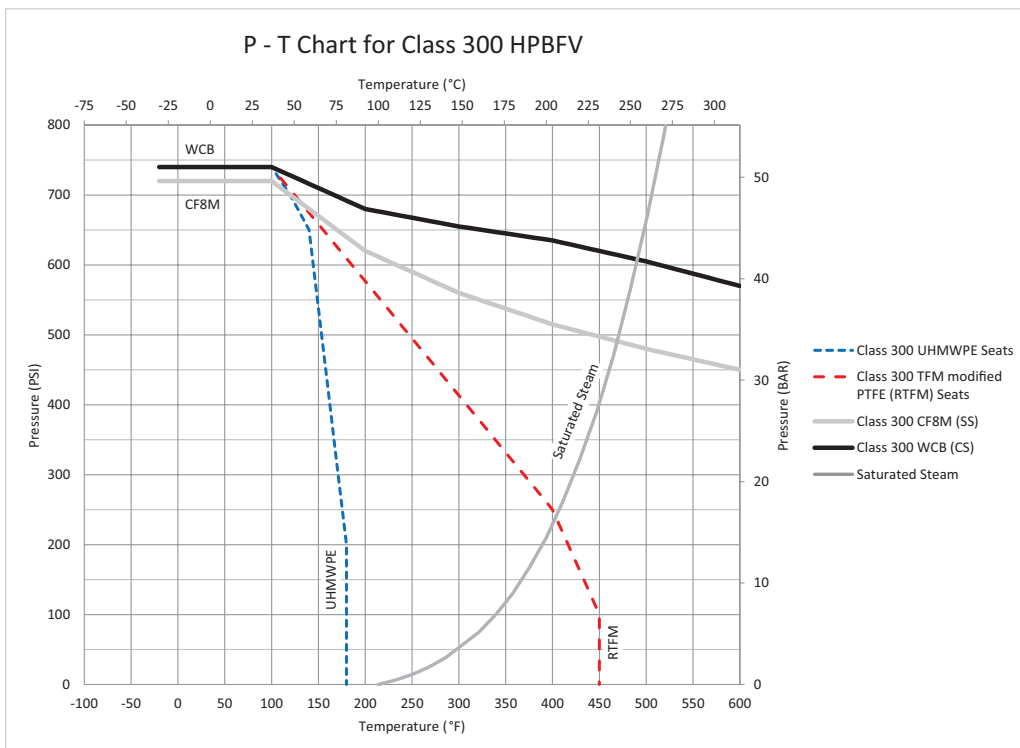

PRESSURE TEMPERATURE RATINGS

Class 600 – Double Offset High Performance Butterfly Valves

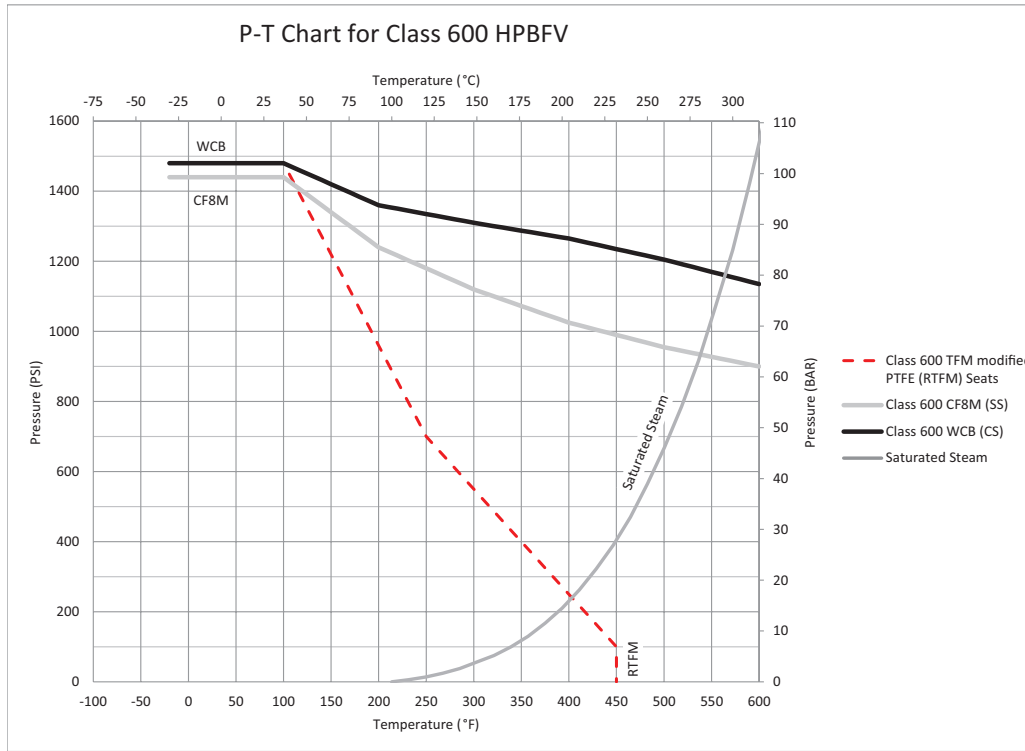

DOUBLE OFFSET HIGH PERFORMANCE BUTTERFLY VALVES

How To Specify

2	15	L	06	C	S	P	8T	A	0
VALVE TYPE	CLASS	VALVE STYLE	SIZE	BODY MATERIAL	DISC MATERIAL	STEM MATERIAL	SEAT MATERIAL	SPECIAL SERVICE	OPERATOR
2 - Double Offset	15 (150)	L - Lug	02 (2")	C - Carbon Steel	S - 316 SS	P - 17-4 PH SS	8T - TFM 1700 w/Glass (Soft Seated)	A - Standard Apollo	0 - Bare Stem 1 - Lever Operator ³ 2 - Worm Gear Operator 5 - Worm Gear Operator w/ Chain Wheel 7 - Locking Worm Gear Operator 8 - Locking Worm Gear Operator w/ Chain Wheel
	30 (300)	W - Wafer	25 (2.5")	S - 316 SS			2F - TFM/Inconel, Graphite Seals (Fire Safe)		
	60 (600) ¹		03 (3")				2M - Duplex 2205 (Metal Seated)		
			04 (4")	A - Alloy 20	A - Alloy 20	A - Alloy 20	21 - UHMWPE ⁴		
			05 (5")	B - 317 SS	B - 317 SS	B - 317 SS			
			06 (6")	H - Hastelloy C	H - Hastelloy C	H - Hastelloy C			
			08 (8")	J - Duplex	J - Duplex	J - Duplex			
			10 (10")	K - Super Duplex	K - Super Duplex	K - Super Duplex			
			12 (12")	M - Monel	M - Monel	M - Monel			
			14 (14")			S - 316 SS			
			16 (16")						
			18 (18")						
			20 (20")						
			24 (24")						
			30 (30") ²						
			36 (36") ²						

¹ Class 600 valves available in sizes 3" through 12" (excluding 5" size)

² 215L Only

³ Lever operators available with all seat configurations, 2"-6" Class 150 (215) and 2"-6" Class 300 (230) valves. Lever operators available for soft seated configurations (TFM 1700 & UHMWPE), 8"-12" Class 150 (215) and 8"-10" Class 300 (230) valves.

Safety Warning:

Gear operators are normally specified for 8" and larger high performance butterfly valves because the force of the pipeline flow on the disc can be too great to safely use a handle.

Safety Warning:

Limit 8" Class 150 (215) & 6"-8" Class 300 (230) valves with lever operators to 150psi maximum differential pressure service.

Limit 10"-12" Class 150 (215) & 10" Class 300 (230) valves with lever operators to 50psi maximum differential pressure service.

⁴ UHMWPE not available in Class 600

Example:

215L06CSP8TA0: 6" Class 150 Lug, Carbon Steel Body, SS Disc, 17-4 PH Stem, TFM 1700 Seats, Standard Service, Bare Stem

Warranty and Limitations of Liability

Conbraco Industries, Inc. warrants, to its initial purchaser only, that its products which are delivered to the initial purchaser will be of the kind described in the order or pricelist and will be free of defects in workmanship or material for a period of TWO years from the date of delivery to you, our initial purchaser.

Should any failure to conform to this warranty appear within two years after the date of the initial delivery to our initial purchaser, Conbraco will, upon written notification thereof and substantiation that the goods have been stored, installed, maintained and operated in accordance with Conbraco's recommendations and standard industry practice, correct such defects by suitable repair or replacement at Conbraco's own expense.

THIS WARRANTY IS EXCLUSIVE AND IS IN LIEU OF ANY IMPLIED WARRANTY OF MERCHANTABILITY, FITNESS FOR A PARTICULAR PURPOSE OR OTHER WARRANTY OF QUALITY WHETHER EXPRESSED OR IMPLIED, EXCEPT THE WARRANTY OF TITLE AND AGAINST PATENT INFRINGEMENT. Correction of non-conformities, in the manner and for the period of time provided above, shall constitute fulfillment of all liabilities of Conbraco to our initial purchaser, with respect to the goods, whether based on contract, negligence, strict tort or otherwise. It is the intention of Conbraco Industries, Inc. that no warranty of any kind, whether express or implied, shall pass through our initial purchaser to any other person or corporation.

LIMITATION OF LIABILITY: Conbraco Industries, Inc. SHALL NOT UNDER ANY CIRCUMSTANCES BE LIABLE FOR SPECIAL OR CONSEQUENTIAL DAMAGES SUCH AS, BUT NOT LIMITED TO, DAMAGES OR LOSS OF OTHER PROPERTY OR EQUIPMENT, LOSS OF PROFITS OR REVENUE, COST OF CAPITAL, COST OF PURCHASED OR INITIAL PURCHASER, AND ALL OTHERS, SET FORTH HEREIN ARE EXCLUSIVE, AND THE LIABILITY OF CONBRACO WITH RESPECT TO SAME SHALL NOT, AS EXPRESSLY PROVIDED HEREIN, EXCEED THE PRICE OF THE GOODS UPON WHICH SUCH LIABILITY IS BASED.

SECTION S – DOUBLE OFFSET HIGH PERFORMANCE BUTTERFLY VALVES

REVISIONS

PAGE	DATE	DESCRIPTION
S-16	20APR16	Added additional stem material list and updated specification note 3
S-6 thru S-8	25APR16	Added bolt hole count to Column G and ISO mounting pattern designation to Column H
S-16	09MAY16	Clarified Lever Operator footnote. Added safety warning for 8" and larger valves.