

PRODUCT SPECIFICATIONS

Ferguson Exclusive Elkay Crosstown 31-1/2" x 20-1/4" x 9" Stainless Steel Double Bowl Farmhouse Sink w/Aqua Divide. Sink is manufactured from 18 gauge 304 Stainless Steel with a Polished Satin finish, Rear Center drain placement, and Sound Guard.

Installation Type:	Farmhouse
Material:	304 Stainless Steel
Special Features:	Aqua Divide
Finish:	Polished Satin
Gauge:	18
Sound Deadening:	Sound Guard
Number of Bowls:	2
Sink Dimensions:	31-1/2" x 20-1/4" x 9"
Bowl 1 Dimensions:	17" x 17" x 9"
Bowl 2 Dimensions:	12" x 17" x 9"
Drain Size:	3-1/2" (89mm)
Drain Location:	Rear Center
Minimum Cabinet Size:	36"
Mounting Hardware:	Part # 54300008 included

Special Note: Available exclusively at Ferguson and Build.com.

Installation Profile:

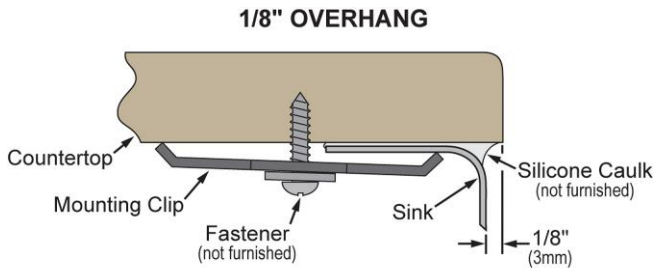

Designed to affix to the underside of any solid surface countertop.

OPTIONAL ACCESSORIES

Drain:	LK35, LKDS35, LK99S
Sinkmate:	LKSMHSL

PART: _____ QTY: _____
 PROJECT: _____
 CONTACT: _____
 DATE: _____
 NOTES: _____
 APPROVAL: _____

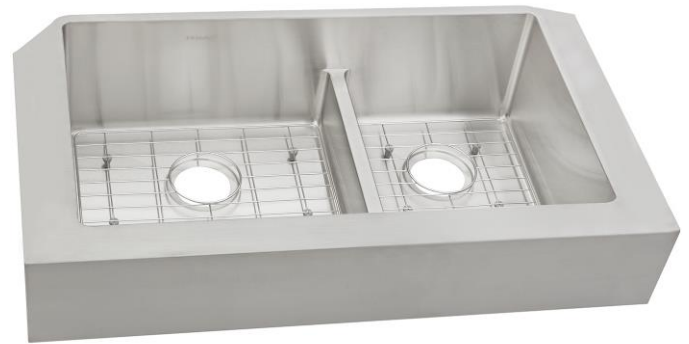

Included with Product: ECTRAF3220RBG sink,
one GFOBG1717SS bottom grid,
one GFOBG1217SS bottom grid

AMERICAN PRIDE. A LIFETIME TRADITION.
Like your family, the Elkay family has values and traditions that endure. For almost a century, Elkay has been a family-owned and operated company, providing thousands of jobs that support our families and communities.



Sinks are listed by IAPMO[®] as meeting the applicable requirements of the Uniform Plumbing Code[®], International Plumbing Code[®], and National Plumbing Code of Canada.

Product Compliance: ASME A112.19.3/CSA B45.4

[Clean and Care Manual \(PDF\)](#)

[Installation Instructions \(PDF\)](#)

[Limited Lifetime Warranty \(PDF\)](#)

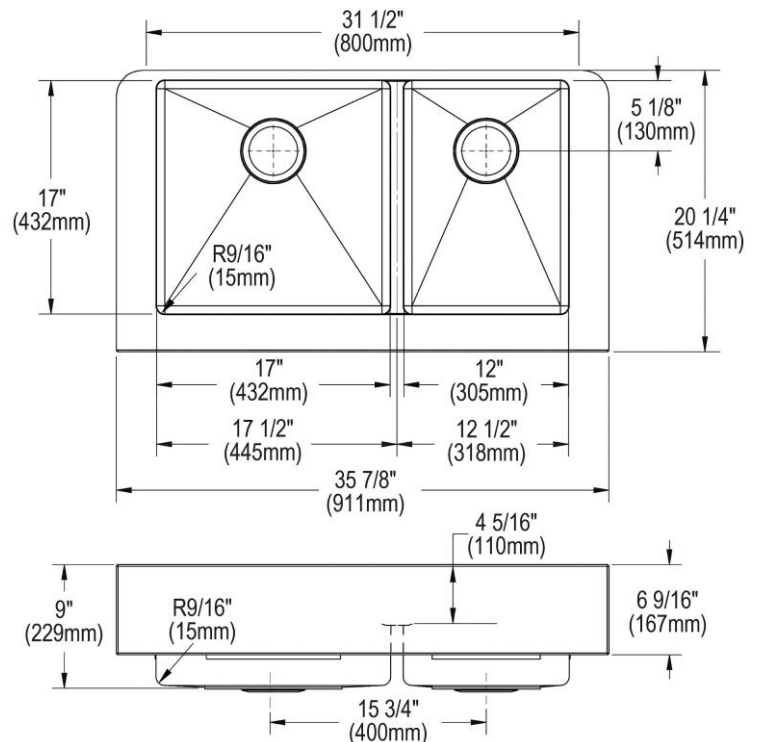

In keeping with our policy of continuing product improvement, Elkay reserves the right to change product specifications without notice. Please visit elkay.com for the most current version of Elkay product specification sheets. This specification describes an Elkay product with design, quality, and functional benefits to the user. When making a comparison of other producers' offerings, be certain these features are not overlooked.