



# McGuire Manufacturing Co., Inc.

60 Grandview Court  
 Cheshire, Connecticut 06410  
 (203) 699-1801 Fax (203) 699-1813  
 customerservice@mcguiremfg.com mcguiremfg.com

## PRODUCT SPECIFICATION

Part No.

**LF2166**

**Closet Supply**  
**1/2" I.P.S. x O.D.**

**Job Name:**

**Submittal Number:**

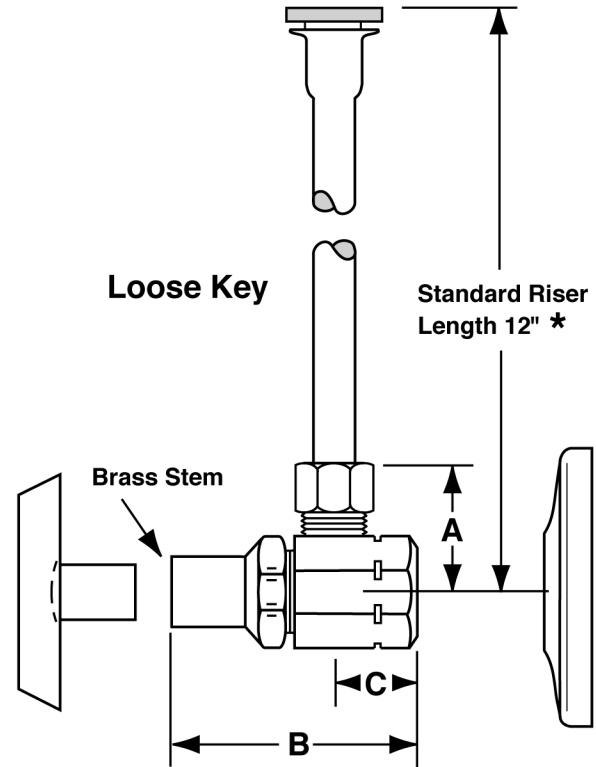
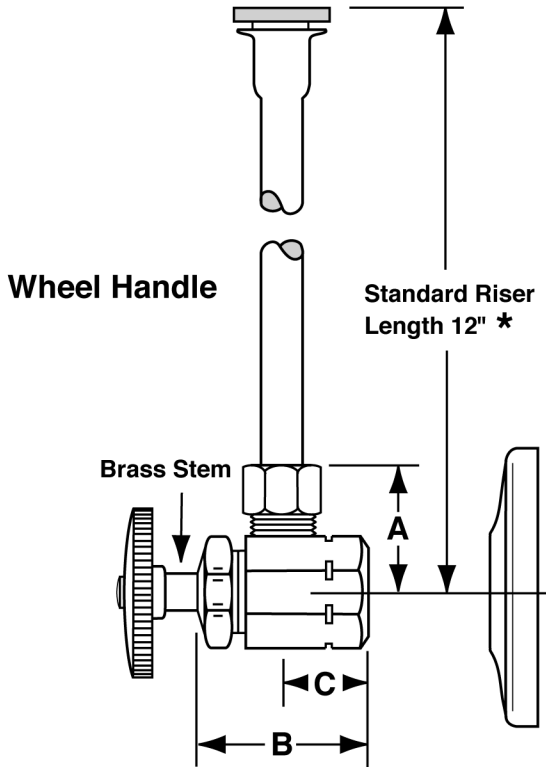

NO.	DESCRIPTION	ROUGHING MEASUREMENTS		
		A	B	C
<b>LF2166</b>	1/2" I.P.S. x 3/8" O.D.	1"	1-1/2"	3/4"

- Rated Operating Pressure: 20-125 PSI
- Rated Operating Temperature: 40-140°F
- Note: 180°F max. during temporary high-temperature system flush

**LK** designates Loose Key

\* See options and accessories section for details on product variations.



## Specifications:

Supply kit shall include lead free chrome plated brass supply stop valves with full turn brass stem, no plastic, (12, 15, 20) inch chrome plated risers and (shallow, deep, bell) (steel, brass) or (forged brass with set screw) flange. Inlet shall be (3/8, 1/2) inch (IPS, sweat, compression). Outlet shall be (3/8, 1/2) inch (IPS, compression). Supply kit shall be McGuire \_\_\_\_\_. Supply kit shall be certified by recognized authority and bear manufacturer and testing mark.



### WARNING:

This product can expose you to chemicals including lead, which is known to the State of California to cause cancer, and birth defects or other reproductive harm. For more information go to [www.P65Warnings.ca.gov](http://www.P65Warnings.ca.gov).