

SUBMITTAL INFORMATION

Uni-Flange Series - (UFR1399-C-x-I style)

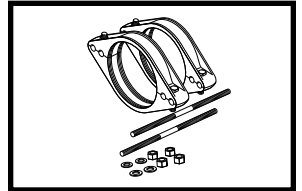

4"-12" UNI-FLANGE SERIES 1399-C RESTRAINT DEVICE FOR DUCTILE IRON, C900 OR C909 PVC BELL JOINTS

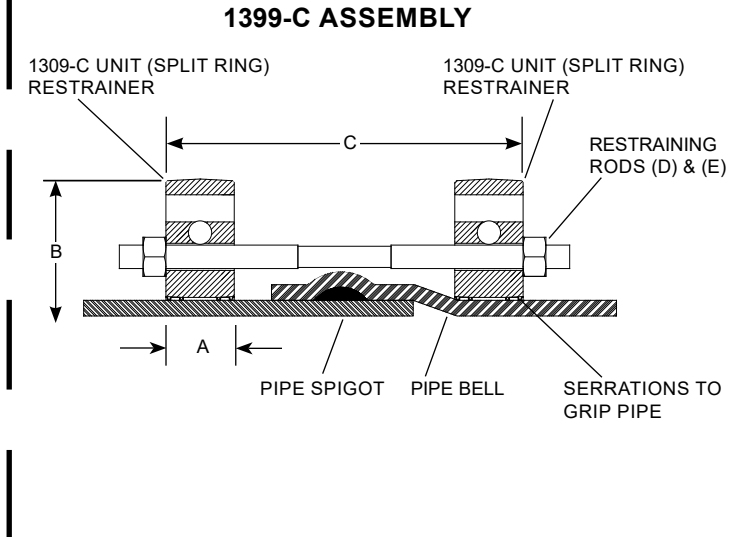
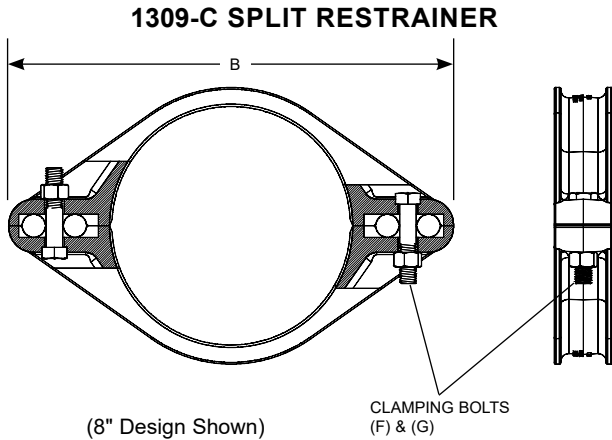

NOM PIPE SIZE	PVC PIPE WITH DI PIPE OD STYLE 1399-C		A	B APPROX.	C MAX	RESTRAINING RODS		CLAMPING BOLTS		BC MAX	BC MIN	APPROX. WT. LBS.	✓ SUBMITTED ITEM(S)
	OD	CATALOG No.				No. D	SIZE E	No. F	SIZE G				
4"	4.80	UFR1399-C-4-I	2.2"	10.8"	15"	2	3/4" x 17"	4	5/8" x 2-1/2"	7.50"	7.50"	20.40	
6"	6.90	UFR1399-C-6-I	2.2"	12.8"	15"	2	3/4" x 17"	4	5/8" x 2-1/2"	9.50"	9.50"	25.00	
8"	9.05	UFR1399-C-8-I	2.2"	16.73"	15"	2	3/4" x 17"	4	5/8" x 3"	14.85"	11.75"	32.00	
10"	11.10	UFR1399-C-10-I	2.2"	19.06"	15"	4	3/4" x 17"	4	5/8" x 3"	15.00"	14.00"	55.68	
12"	13.20	UFR1399-C-12-I	2.2"	21.38"	15"	4	3/4" x 17"	4	5/8" x 3"	17.50"	16.25"	66.24	

FEATURES

- 4" - 12" sizes: Cast ductile iron per ASTM A536 grade 65-45-12
- Black Armorguard e-coat applied epoxy
- 360° contact and support of the pipe wall
- Clamping pads and tie rod lugs co-located so installer doesn't have to work under the pipe.
- Restraining Rods (included) - High strength, low alloy steel ANSI / AWWA C111 / A21.11.
- Side Clamping Bolts and Nuts - Grade 5, zinc-plated
- Rated at full-rated pressure of any class of C900 and C909 PVC pipe, minimum 2:1 safety factor
- Rated at 250 psi on sizes 4"-8", 200 psi on 10" and 150 psi on 12" on ANSI A21.51/AWWA C-151 ductile iron pipe

The Ford Meter Box Company considers the information in this submittal form to be correct at the time of publication. Item and option availability, including specifications, are subject to change without notice. Please verify that your product information is current.



The Ford Meter Box Company, Inc.
 P.O. Box 443, Wabash, Indiana U.S.A. 46992-0443
 Phone: 260-563-3171 / Fax: 800-826-3487
 Overseas Fax: 260-563-0167
 www.fordmeterbox.com

09/14/17

Submitted By: